

**Lower Thames Crossing
6.3 Environmental Statement
Appendices
Appendix 6.8 – Trial Trenching
Reports (Volume C)**

APFP Regulation 5(2)(a)

Infrastructure Planning (Applications:
Prescribed Forms and Procedure)
Regulations 2009

Volume 6

DATE: October 2022

Planning Inspectorate Scheme Ref: TR010032
Application Document Ref: TR010032/APP/6.3

VERSION: 1.0

Lower Thames Crossing

6.3 Environmental Statement Appendices

Appendix 6.8 – Trial Trenching Reports (Volume C)

List of contents

Volume A

Archaeological Evaluation Report for Trial Trenching of Land Parcel 1 Masons Corner, Heath Road, Orsett Heath, Essex

OA Archaeological Evaluation Report for Trial Trenching of Land Parcel 2

Archaeological Evaluation Report for Trial Trenching of Land Parcels 3 (North), 30 and 35

Archaeological Evaluation Report for Trial Trenching of Land Parcel 3 Hornsby Lane, Orsett Heath, Essex

Archaeological Evaluation Report for Trial Trenching of Land Parcel 4 Old House, Chadwell St Mary, Essex

Archaeological Evaluation Report for Trial Trenching of Land Parcel 5 Brook Farm, Essex

Archaeological Evaluation Report for Trial Trenching of Land Parcels 6-8, Land West of Linford, East Tilbury, Essex

Archaeological Evaluation Report for Trial Trenching of Land Parcels 6, 8, 9, 10 and 36

Archaeological Evaluation Report for Trial Trenching of Land Parcel 12, Land South of Low Street, Tilbury Marshes, Essex

Volume B

OA Archaeological Evaluation Report for Trial Trenching of Land Parcel 21

Archaeological Evaluation Report for Trial Trenching of Land Parcel 22 Whitfield South Scheduled Monument Cropmark Complex, South of Stifford Clays Road, Baker Street, Essex

Archaeological Evaluation Report for Trial Trenching of Land Parcels 3 (North), 30, 31, 35, 103, 104 and 107 Land Bordering the A13 at Orsett, Essex

Archaeological Evaluation Report for Trial Trenching of Land Parcel 37

Archaeological Evaluation Report for Trial Trenching of Land Parcels 55, 56 and 58

Volume C

OA Archaeological Evaluation Report for Trial Trenching of Land Parcel 24, 25, 26, 28 & 29

Archaeological Evaluation Report for Trial Trenching of Land Parcels 40 and 49, North Ockendon, London Borough of Havering

Archaeological Evaluation Report for Trial Trenching of Land Parcels 41, 42, 44 and 60 Land South of Ockendon, in Thurrock, Essex, and the London Borough of Havering

Archaeological Evaluation Report for Trial Trenching of Land Parcels 43, 45A-E and 46 Mar Dyke Valley, between South Ockendon and Orsett

Archaeological Evaluation Report for Trial Trenching of Land Parcels 47 and 48f-h, Mar Dyke Valley between South Ockendon and Orsett, Essex

Archaeological Evaluation Report for Trial Trenching of Land Parcels 48B and 48C Mar Dyke Valley, between South Ockendon and Orsett

Volume D

Archaeological Evaluation Report for Trial Trenching of Land Parcels 54 and 126 Land North of North Ockendon, London Borough of Havering

Archaeological Evaluation Report for Trial Trenching of Land Parcels 71, 72 and 75 Land east of Gravesend and either side of the A226, Chalk, Kent

Archaeological Evaluation Report for Trial Trenching of Land Parcels 76 and 77

Volume E

Archaeological Evaluation Report for Trial Trenching of Land Parcels 80 and 81

COVER SHEET

Title:	OA Archaeological Evaluation Report for Trial Trenching of Land Parcel 24, 25, 26, 28 & 29
Project Name:	Lower Thames Crossing Enabling Works
Ref No:	HE540039-BAL-GEN-GEN-REP-HER-00028
Revision No:	P02
Review Date:	06/08/2021
Status:	S2 – For Information
No. of Pages	137

Rev	Date of Issue	Revision Status	Originator	Checker	Approver
P01	11/01/2021	S2 – For Information	Bikash	Jack Fletcher	Emily Erswell
P02	06/08/2021	S2 – For Information	Jack Fletcher	Sam Ashton	Emily Erswell



Lower Thames Crossing

Archaeological Evaluation Report for Trial Trenching of
Land Parcels 24, 25, 26, 28 and 29,
Baker Street, Essex

Document Number: HE540039-BAL-GEN-GEN-REP-HER-00028

August 2021



Revision	Production Date	Prepared by	Checked by	Approved for release by	Sections revised
1.0	November 2020	<i>Steve Teague Post-excavation Project Officer, Oxford Archaeology</i>	<i>Tim Allen Senior Project Manager, Oxford Archaeology</i>	<i>Internal review only</i>	
1.1	December 2020	<i>revised by: Tim Allen Senior Project Manager, Oxford Archaeology</i>	<i>Steve Lawrence Senior Project Manager, Oxford Archaeology</i>		
2.1	July 2021	<i>revised by: Kate Brady Post-excavation Project Officer, Oxford Archaeology</i>	<i>Steve Lawrence Senior Project Manager, Oxford Archaeology</i>		<p>Summary 1.1.5, 3.2.1, 3.2.5, 4.1.3, 4.3.1</p> <p>new section inserted at 4.4 (this has adjusted all subsequent paragraph numbers in section 4)</p> <p>4.15, 4.16, Section 5</p> <p>Appendices A, B5, C1, C2, F</p>

This Evaluation Report has been prepared for Highways England in accordance with the terms and conditions of appointment stated in the Lower Thames Crossing (LTC) Technical Partner Contract. LTC cannot accept any responsibility for any use of or reliance on the contents of this document by any third party.

Contents

Section	Page
Summary	6
Acknowledgements	7
1 Introduction	8
1.1 Project details and scope of work	8
1.2 Location, topography and geology	9
1.3 Previous investigations	9
1.4 Archaeological and historical background	9
2 Project Aims	14
2.1 General aims	14
2.2 Specific objectives	15
3 Methodology	16
3.1 Constraints	16
3.2 Methodology for the evaluation	16
4 Results	17
4.1 Introduction and presentation of results	17
4.2 General soils and ground conditions	17
4.3 General distribution of archaeological deposits	17
4.4 Land Parcel 24: Trenches 16-17, 19-21, 23-24 and 25-29 (Figs 3-8) ..	18
4.5 Land Parcel 25: Trenches 1-3 (Figs 9 and 10)	20
4.6 Land Parcel 26: Trenches 35 and 36 (Figs 11 and 12)	20
4.7 Land Parcel 28 west (Figs 13 and 14)	20
4.8 Land Parcel 28 east (Figs 15-17)	23
4.9 Land Parcel 28 south (Figs 18 and 19)	26
4.10 Land Parcel 29 west (Figs 20 and 21)	28
4.11 Land Parcel 29 north (Figs 22 and 23)	28
4.12 Land Parcel 29 south-west (Figs 24 and 25)	28
4.13 Land Parcel 29 south (Figs 26 and 27)	29
4.14 Land Parcel 29 south-east (Figs 26, 28 and 29)	31
4.15 Finds summary	32
4.16 Environmental summary	33
5 Discussion	34
5.1 Reliability of field investigation	34
5.2 Interpretation	34
5.3 Evaluation objectives and results	36
Appendix A Trench Tables	39
Appendix B Finds Reports	88
Appendix C Environmental Reports	95
Appendix D References	98
Appendix E Abbreviations and Glossary	100

Figures

Figure 1: Map showing the location of Land Parcels 24-29

Figure 2: Trench layout and cropmark features

Figure 3: Plan of Trenches 16-20, Land Parcel 24

Figure 4: Sections (Trenches 16 and 19)

Figure 5: Plan of Trenches 21-25, Land Parcel 24

Figure 6: Sections (Trenches 21, 23, 24 and 25)

Figure 7: Plan of Trenches 26-29, Land Parcel 24

Figure 8: Section (Trench 26)

Figure 9: Plan of Trenches 1-4, Land Parcel 25

Figure 10: Sections (Trench 1)

Figure 11: Plan of Trenches 35 and 36, Land Parcel 26

Figure 12: Section (Trench 36)

Figure 13: Plan of Trenches 51, 52, 61, 62, 63, 71, 72 and 73, Land Parcel 28

Figure 14: Sections (Trenches 52, 62, 63 and 72)

Figure 15: Plan of Trenches 57, 59, 60, 74, 78, 79, 95 and 96, Land Parcel 28

Figure 16: Sections (Trenches 57, 59, 60 and 74)

Figure 17: Sections (Trenches 78, 79 and 96)

Figure 18: Plan of Trenches 80, 81, 82, 92, 93, 94 and 99, Land parcel 28

Figure 19: Sections (Trenches 80, 81, 92, 93, 94 and 99)

Figure 20: Plan of Trenches 103 and 106, Land Parcel 29

Figure 21: Sections (Trenches 103 and 106)

Figure 22: Plan of Trenches 111, 113 and 133, Land Parcel 29

Figure 23: Sections (Trenches 111 and 133)

Figure 24: Plan of Trenches 123 and 142, Land Parcel 29

Figure 25: Sections (Trenches 123 and 142)

Figure 26: Plan of Trenches 120, 121, 129, 130, 138, 139, 140, 145, 146, 152, 153, 154 and 156, Land Parcel 29

Figure 27: Sections (Trenches 120, 129, 130, 138, 153 and 154)

Figure 28: Plan of Trenches 137, 147, 148, 149, 150 and 151, Land Parcel 29

Figure 29: Sections (Trenches 137, 149, 150 and 151)

Plates

Plate 1: Ditch 7107, facing south

Plate 2: Ditch 6003, facing south-east

Plate 3: Posthole 7407, facing south

Plate 4: Trench 78, facing north

Plate 5: Ring ditch 7809, facing east

Plate 6: Ditches 7907 and 7909, facing south

Plate 7: Ditch 8003, facing east

Plate 8: Ditch 8106, facing north

Plate 9: Ditch 9305, facing south-east

Plate 10: Pit 9903, facing north-west

Tables

Table 1: Prehistoric pottery by context, sherd number, weight and date

Table 2: Flints by context, type, sub-type and provisional date

Table 3: Metal finds by context, type, description and date

Table 4: Slag by context

Table 5: Assessment of bulk CPR samples

Summary

Oxford Cotswold Archaeology was commissioned by Balfour Beatty to undertake a trial trench evaluation of Land Parcels 24-29 of the Lower Thames Crossing Pre-Enabling Works. The land parcels are located directly south-west of the hamlet of Baker Street and north-east of the suburbs of Grays within the county of Essex and Thurrock unitary authority (NGR 563334 180597). At the time of fieldwork only Land Parcels 24, 25, 26, 28 and 29 were available for trenching. The evaluation comprised the excavation of 145 trenches and was completed between 19th and 20th March 2020 (Land Parcel 25), 11th August and 9th September 2020 (land Parcels 26 and 28-29), and 11th and 14th May 2021 (Land Parcel 24).

The evaluation confirmed the presence of a circular cropmark ring ditch in Land Parcel 28, which contained much of a single vessel dated to the later Bronze Age or (more likely) the early Iron Age. The absence of cremated remains may indicate that this ditch was more likely to have surrounded a roundhouse than to have originated as a burial monument. Two undated curvilinear gullies within 50m may have formed part of smaller enclosures. Small ring ditches were revealed in Land Parcel 24, along with a small number of other dated features: a pit and a ditch. Pottery dates these features to the late Bronze Age to early Iron Age period.

The cropmark ditch system aligned NNW-SSE by WSW-ENE in Land Parcel 28 was confirmed by evaluation, and was more extensive than indicated by the cropmarks, but had insufficient finds to date it. In Land Parcel 29 a further ditch system on the same alignments was found, one ditch containing a brick fragment of late medieval or early post-medieval date. This ditch was in line with one of the ditches in Land Parcel 28, and they were probably both parts of one wider field system. Some ditches corresponded with the extant western field boundary of Land Parcel 26, which a tithe map and early Ordnance Survey maps show was then part of a system of smaller fields to the north. The evidence suggests that evaluated ditch is a still earlier system of early post-medieval or (just possibly) late medieval origin.

A regular alignment of large, discrete cropmarks in Land Parcel 28 was shown to consist of natural features.

Acknowledgements

Oxford Cotswold Archaeology would like to thank the client, Balfour Beatty, for commissioning this project and managing the site safety and attendances. Thanks are also extended to the Historic Environment Consultant, Richard Havis of Place Services for Essex County Council advising the Borough of Thurrock, for monitoring and providing advice throughout the project.

The project was managed for Oxford Cotswold Archaeology by Steve Lawrence. The fieldwork was directed by Mark Dodd, who was supported by Adrian Arenas, Steve Arrow, Eilidh Barr, Anne-laure Bollen, Benjamin Camp, Fanny Dubuc, James Fish, Chris Griffiths, George Gurney, Tamara Hadnagyev, Jack Heathcote, Samuel McCormick, Melanie Sayer, Daniel Sendek, Zsuzsanna Veres and Katherine Whitehouse. Site survey was undertaken by Caroline Souday, digitising was carried out by Aidan Farnan and Gary Jones and illustrations were by Sophie Lamb.

1 Introduction

1.1 Project details and scope of work

- 1.1.1 The Lower Thames Crossing Project is located between the A2 in Kent and the M25 in the London Borough of Havering. It will run underneath the River Thames in a tunnel and emerge on the northern side of the river at East Tilbury. From the North Portal the road will run to the M25 at Junction 29 via the A13 and pass in between North and South Ockendon. The development of the project is being managed by LTC, a partnership between Highways England and a consultancy joint venture set up to oversee the scheme.
- 1.1.2 A programme of archaeological trial trenching began in the Essex part of the scheme in November 2019. A scheme-wide specification for trial trenching was written by LTC (Highways England 2018), and in July 2019 LTC commissioned Balfour Beatty to deliver the pre-enabling works. Balfour Beatty appointed Oxford Archaeology (hereafter OA) to prepare a project-wide written scheme of investigation (WSI) for the scheme, which (at the request of the key archaeological stakeholders) is divided into two parts, one for the Kent section, the other for Essex and Havering (Oxford Archaeology 2019a, 2019b).
- 1.1.3 Following completion of the project-wide WSIs, OA was instructed to prepare a series of site-specific or group-site-specific WSIs for approval by the key archaeological stakeholders in advance of trial trenching to inform the Development Consent Order (DCO). A detailed WSI was created for Land Parcels 24-29 prior to the trial trenching (Oxford Archaeology 2020). The WSI detailed the archaeological background and potential within Land Parcels 24-29, indicated the archaeological aims and objectives appropriate to the investigation of this land parcel by trenching and set out the methodology. This WSI was approved by Richard Havis, Principal Historic Environment Consultant for Place Services, Essex County Council, prior to the start of the fieldwork.
- 1.1.4 Oxford Cotswold Archaeology (hereafter OCA) was commissioned as Balfour Beatty's archaeological contractor to undertake the evaluation in accordance with the approved WSI and local and national planning policies. At the time of fieldwork Land Parcels 24, 25, 26, 28 and 29 were available for evaluation.
- 1.1.5 The fieldwork was completed in three phases between 19th and 20th March 2020 (Land Parcel 25), 11th August and 9th September 2020 (Land Parcels 26 and 28-29), and 7th and 14th May 2021 (Land Parcel 24).
- 1.1.6 All work followed the MoRPHE Project Manager's guide (Historic England 2015), and the code of conduct of the Chartered Institute for Archaeologists (CIfA). The archaeological works adhered to the standards and guidance for archaeological evaluation, excavation and archiving (CIfA 2014a, 2014b).
- 1.1.7 The work was monitored by Richard Havis of Place Services, Essex County Council, advising the Borough of Thurrock.

1.2 Location, topography and geology

- 1.2.1 The five land parcels (hereafter the site) are located directly south-west of the hamlet of Baker Street and north-east of the suburbs of Grays (Fig. 1) within the county of Essex and Thurrock unitary authority (NGR 563334 180597). The site is bounded to the west by residential properties of the town of Grays and fields north of that, to the east by Baker Street and the A1089, and to the south by Gammonfields Way and the A1013 Stanford Road. The northern edge of the site is defined by the A1089 slip road and this road and the A13 also bisects the northern part of the site. The southern part of the site is bisected by Long Lane.
- 1.2.2 The bedrock geology of the site is mixed, with Lambeth Group (clay, silt and sand) underlying the northern part of the site and Thanet Formation (sand) underlying the southern edge of the site. The superficial geology of the land parcel is the Boyn Hill Gravel Member (sand and gravel) (BGS 2019).
- 1.2.3 The site has a mixed use, though the majority is used as arable fields and scrubland.

1.3 Previous investigations

- 1.3.1 No known below-ground archaeological investigation has been undertaken within the site, but archaeological investigation have taken place along the line of the A13 adjacent to the north part of the site prior to and during its construction (Wilkinson 1988).
- 1.3.2 Archaeological evaluation of the Grey Goose Farm scheduled cropmark complex to the north and north-west of this site has also been carried out for the Lower Thames Crossing scheme, and the results are included in the background described below (OCA 2020a).

1.4 Archaeological and historical background

- 1.4.1 The chronological summary of known archaeology given below is taken from the detailed WSI for Land Parcels 24-29 (Oxford Archaeology 2020). The site is situated on the terrace to the south of the Mar Dyke valley where Holocene prehistoric features, find spots and cropmarks have been identified.
- 1.4.2 **Palaeolithic.** No Palaeolithic finds have been recorded within the site or within a 0.5km radius of the site.
- 1.4.3 **Mesolithic.** Residual Neolithic and Mesolithic flints were recorded at William Edwards School in 1997, located 0.6km west of the site. Mesolithic finds have also been recorded to the south-east some 0.9-1km from the site.
- 1.4.4 **Neolithic.** No Neolithic features or finds are known within the site. A narrow rectangular enclosure was recorded as a cropmark 0.5km east of the site. This feature was aligned east-west with rounded ends and from its morphology this is suspected to be a mortuary enclosure of Neolithic date.
- 1.4.5 A part-polished Neolithic axe was recorded 0.5km south-west of the site.
- 1.4.6 In the wider area an early Neolithic causewayed enclosure is located 1.5km east of the land parcel, and several finds of Neolithic flints have been made from the area south of the enclosure.
- 1.4.7 **Early Bronze Age.** No early Bronze Age activity is known within the site. A cropmark ring ditch lies 350m east of the site, and another larger cropmark ring

ditch lies 700m north of the site. These may be the remains of early Bronze Age barrows, indicating activity of this date in the surrounding area.

- 1.4.8 **Later Bronze Age and Iron Age.** A small ring ditch is located within the southern part of the site, within a larger cluster of cropmark features. Several more, small ring ditches are known within the dense cluster of cropmarks of the Orsett (Grey Goose Farm) Cropmark Complex immediately north and north-west of the site, including one located c 30m west of the site, one located c 100m west of the site and a cluster of four or five located 150-200m north of the site. These circular ring ditches are c 12-16m in diameter and evaluation has shown that one is probably of later Bronze Age date, while others represent roundhouses dating to the later Iron Age (OCA 2020a). Another likely example of a possible roundhouse gully is visible as a cropmark at Baker Street, located 0.2km north-east of the site on the north edge of the terrace.
- 1.4.9 During excavation on the line of the A13 where it passed through the cropmark complex in 1979, several features dating to the late Bronze Age to early Iron Age were recorded, including large and small pits, postholes, and a short length of gully (Wilkinson 1988, 13-16). The LTC evaluation of the cropmark complex revealed a cremation of late Bronze Age date and finds indicating a focus of late Bronze Age/early Iron Age activity in this area, although most of the finds appeared to be residual in later features, and none of the features that were investigated were unequivocally late Bronze Age/early Iron Age. Most of the discrete cropmark features interpreted as pits proved to be geological features (OCA 2020a).
- 1.4.10 Towards the south of the site two clusters of cropmarks have been recorded by the aerial survey. In addition to the small ring ditch mentioned above, the easterly set of cropmarks contains a number of linear features orientated NNNW-SSE and NE-SW, some being parallel pairs, possibly indicating trackway ditches. This set of cropmarks also includes small discrete features, along with five sub-circular features up to 17m in diameter. These large features are in a NW-SE alignment and it is possible that these are bomb craters or quarry pits, and so more recent than the others in this cluster.
- 1.4.11 The westerly set of cropmarks includes two irregular linear features, one aligned roughly NNW-SSE and the other ENE-WSW, along with two shorter linear features and a spread of discrete, pit-like features. These features are similar to those found in the A13 excavations and could date to the late Bronze Age or early Iron Age.
- 1.4.12 A handful of late Bronze Age/early Iron Age features were recorded at William Edwards School in 1997, located 0.6km west of the site. This included one large and several smaller pits, linear features and a well cut by one of the pits (Lavender 1998, 19-24).
- 1.4.13 Another prehistoric scheduled monument, comprising a middle to late Bronze Age Springfield-style enclosure (or ring-fort) and an overlying settlement believed to date to the Iron Age, is located to the east of the Orsett cropmark complex, c 500m to the north-east of the site boundary. Further cropmark features, including the small ring ditch previously mentioned, rectilinear enclosures, pits and a probable trackway, have been identified between this and the site, only 200m from its north-east corner.

- 1.4.14 A late Iron Age farmstead at Stifford Clays-Primrose Island was excavated in the 1960s and 1970s c 0.6km west of the site, while a large quantity of high-status Iron Age material was recovered by metal detectorists from a field 0.9km south-east of the site and within an extensive rectilinear enclosure.
- 1.4.15 In the wider landscape, the Neolithic causewayed enclosure located 1.5km east of the site was overlain by an unenclosed early Iron Age site and a middle Iron Age sub-rectangular enclosure (Hedges and Buckley 1978, 219-308), while middle-late Iron Age activity was also found at Orsett Cock on the line of the A13 to the north.
- 1.4.16 **The Roman period.** No evidence for Roman activity has been recovered from the site. Several sherds of Roman pottery were recovered from ditches and other features during the A13 investigations crossing the Orsett Cropmark Complex at Grey Goose Farm (Wilkinson 1988), indicating activity in the vicinity, but were insufficient to identify features as Roman with confidence.
- 1.4.17 Evaluation carried out in 2020 for the LTC scheme has, however, demonstrated that most of the linear boundaries, rectangular enclosures or part-enclosures, and sub-rounded enclosures within the cropmark complex are of late Iron Age and Roman-period date (OCA 2020a).
- 1.4.18 The late Iron Age farmstead at Stifford Clays-Primrose Island, c 0.6km west of the site, continued in use throughout the Roman period, with enclosures, ditches, pits, cremation burials and a corn-drying oven. A possibly Roman double-ditched enclosure site was identified by aerial photography 0.2km north-east of the site. These Roman-period sites are located along the north edge of the gravel terrace.
- 1.4.19 An extensive cropmark complex that includes one very large rectilinear enclosure and several smaller ones linked by trackways or field boundaries was identified by the aerial survey 0.8km south-east of the site. This was also evaluated for the LTC scheme and proved to be mostly of Roman date, included well-preserved pottery kilns among the notable discoveries (OCA 2020b).
- 1.4.20 Individual findspots of Roman glass were identified 0.6km north-west of the site, although these records may be duplicate entries as one is from the Essex HER and one from Pastscape.
- 1.4.21 **The Saxon and medieval periods.** No Saxon activity is known within the site.
- 1.4.22 A dense pattern of discrete features identified as pits of varying size and shape are dispersed across the Orsett Cropmark Complex scheduled monument and extend into the north-western and north-eastern parts of the site. Some of the pits are thought likely to represent Saxon *Grubenhäuser* (sunken-featured buildings) (Place Services 2019), but excavations in advance of work on the A13 directly to the south indicated that some of these features were of geological origin. Saxon artefacts were, however, recorded from one or two features, demonstrating that there may have been Saxon activity in the vicinity.
- 1.4.23 In the wider landscape, middle Saxon activity has been identified to the east of the land parcel. The Orsett causewayed enclosure scheduled monument (1009286), located 1.5km east of the site, was reused as a Saxon funerary monument in the 7th-8th century, and a Saxon settlement was located 1.8km north-east of the site at Orsett Cock.

- 1.4.24 No medieval activity is known within the site, but the pits and other cropmark features in the northern part of the site may prove to be of medieval date, as fieldwalking in the southern part of the scheduled monument just to the north-west of the site produced a handful of medieval finds.
- 1.4.25 In 1994 a watching brief was undertaken at Grey Goose Farm located c 200m west of the site. A domestic rubbish pit, which contained oyster shell, burnt organic material and medieval pottery dating to the 12th-13th century, was recorded. This suggests that there was medieval activity in the vicinity, possibly a farmstead situated south of the Stifford Clays Road.
- 1.4.26 In the late Saxon and medieval period, the site was located within the parish of Orsett. The nucleated medieval settlement of Orsett was located 1km north-east of the site. It is likely that in the later medieval period the land parcel was used mainly as agricultural land associated with several farmsteads on the outskirts of Orsett. The OS first edition map of 1805 and the Orsett tithe map of 1840 show three roads in close proximity to the site, including the NNW-SSE-aligned Baker Street, the ENE-WSW-aligned Long Lane, which bisects the southern part of the site, and the NE-SW-aligned Stanford Road (now the A1013) to the west of Baker Street. These roads may have originated during the late Saxon or medieval period, as Long Lane linked the medieval settlements of Stifford and Stanford and the Baker Street road linked the east-west Stifford to Orsett road with a road to Chadwell. It is possible that medieval roadside settlements or farmsteads were located along Long Lane, Baker Street and possibly Stanford Road. Medieval activity may be identified within the site either side of Long Lane and north of what is now the Stanford Road. It had been thought less likely that activity would be found west of Baker Street, as this area at the eastern edge of the site had been truncated by the construction of the A1089. It is possible that some of the cropmark features within the south-western and south-eastern part of the site, just north of Long Lane may date to the medieval period, particularly as some of the linear features run parallel and perpendicular to Long Lane.
- 1.4.27 A number of possible medieval droveways have been observed as cropmarks within the wider area and several of these have been identified within the scheduled monument and within the area of the site. These droveways may have been used to take livestock to and from the marshland or lowland to the upland ridge. Several trackways were identified south of the Stifford Clays Road and within the north-eastern part of the site during the 1979 excavation along the A13 just north of the site. One ditch appeared to be a continuation of an NNW-SSE aligned trackway to the north. This ditch contained lumps of chalk thought to be evidence of chalk marling. Another NNW-SSE-aligned ditch was very likely to have continued as a trackway to the north. This ditch cut across a possible earlier settlement as indicated by the cropmarks and it contained residual sherds of either late Iron Age or medieval pottery (the pottery could not be accurately dated). Another trackway was recorded just east of that ditch, orientated NE-SW and containing abraded, probably residual Roman pottery (Wilkinson 1988, 16-17).
- 1.4.28 **Post-medieval period.** Documentary evidence indicates that during the post-medieval period the site was located nearest to the settlement of Baker Street within the parish of Orsett. As mentioned above, Baker Street, Long Lane, and part of the Stanford Road west of Baker Street may have originated in the

medieval period. Baker Street, located immediately adjacent and north-east of the site, contains several listed buildings, including two houses dating to the 15th-16th century, a 17th-century windmill, and an 18th-century house. Two listed buildings are located east and west of Baker Street, including 1 and 2 Grays Corner, an early 19th century house, and Little Wellhouse, a mid-17th century house. The mid-17th century listed Greygoose Farmhouse is also located 200m west of the site and south of Stifford Clays Road. The Orsett tithe map (c 1840) and apportionment indicates that the site belonged to several farms in the later post-medieval period, including Chapel Farm, Wrights Croft, and a farm that was later called Kempsters. The 1840 map shows that a farm with several buildings was located just west of Baker Street at the eastern edge of the site. This farm was owned by William Wingfield of Orsett Hall and leased out to the Kempsters. A number of field boundaries are shown on the 1840 map as part of the Kempsters farm that had disappeared by 1875. In addition, several of the farm buildings appear to have been demolished and replaced by one or two buildings known as Kempsters. It is likely that these field boundaries were removed to replace the smaller fields with one larger field. The field boundaries around Wrights Crofts and several fields to the north-west are still defined by extant hedgerows. The enclosure of Orsett was undertaken in 1837 (National Archives 54/11705/m1/m40/m51) and so these extant fields almost certainly post-date enclosure. The only cropmarks that can be tentatively dated are the NNW-SSE and the ENE-WSW linear field boundaries and trackways which may be medieval or post-medieval in date.

- 1.4.29 The site contains several areas of suspected post-medieval and modern disturbance. In the centre of the site are four large amorphous and sub-rounded features and it is possible that these are post-medieval or modern quarry pits. In addition, there are the set of five sub-circular features up to 17m in diameter within the southern part of the site. These appear to be located just north of features which may be prehistoric or medieval in date, including a ring ditch and several trackways. It is possible that these sub-circular features are quarry pits, or they may be the site of a line of Second World War bomb craters due to their unusually straight alignment. Alternatively, these features may be geological in origin, but their regular alignment makes this less likely.
- 1.4.30 It is probable that the site was disturbed by quarrying, landfill, or landscaping during the A13 widening and A1013 construction in the later 20th century, resulting in disturbance of archaeological remains. There is an area of lower ground within the north-western part of the site in which no superficial deposits appear to survive, and it is likely that soil was removed from this area for landscaping. The extent of disturbance across the site is uncertain, but its likely limits are shown.

2 Project Aims

2.1 General aims

2.1.1 The general aims of the project were as follows:

- i. To establish the presence or absence of archaeological remains along the line of the scheme, and the extent of any areas where remains appear likely to be absent;
- ii. In areas where archaeological remains are known or suspected, to clarify the reliability of the cropmark or geophysical survey evidence;
- iii. In areas where no archaeological remains are indicated by aerial or geophysical survey, to clarify whether this apparent absence of remains is genuine;
- iv. To determine the degree of complexity of any surviving horizontal or vertical stratigraphy and, in particular, to investigate areas where topography indicates the likelihood of deep deposit sequences for evidence of buried archaeological horizons and palaeo-environmental sequences;
- v. Where remains are present, to determine the period(s) represented, the extent, state of preservation and character of the archaeological remains;
- vi. To establish the range and state of preservation of archaeological artefacts, and through their recovery and examination, to establish the potential for information about the economy, status and contacts of past inhabitants of the scheme footprint;
- vii. To determine whether palaeo-environmental remains are preserved, and, where these are found, to determine their types (eg charred plant remains, waterlogged remains, molluscan remains), state of preservation and potential for environmental information. This will be achieved through the recovery of samples from sedimentary sequences and archaeological features suitable for assessment of a range of palaeoenvironmental remains (eg charred and waterlogged plant remains, charcoal, insects, pollen, diatoms, ostracods/foraminifera and molluscs) and scientific dating (eg radiocarbon and OSL dating);
- viii. To investigate and record the extent, character and chronology of the sedimentary sequences, in particular those immediately adjacent to and in floodplains, contained within palaeochannels or in dry valleys, and to use the data to refine existing geoarchaeological (predictive) deposit models;
- ix. To place any identified archaeological remains into their local and, where appropriate, regional or national context, and to assess the implications of any such discoveries for our current understanding of settlement and landscape change in the area, including an assessment of the associations of any remains with reference to the historic landscape;
- x. To provide sufficient information to enable the LTC archaeological advisor, in consultation with the Key Archaeological Stakeholders, to determine the significance of the archaeological assets identified within the land parcel;
- xi. To provide a report on the discoveries to inform the Environmental Statement (ES) supporting the Development Consent Order (DCO) and support the

preparation of a further archaeological mitigation strategy for the Enabling Works and Construction phases of the scheme;

- xii. Following the DCO, to deposit the report in the public domain, and to generate an accessible and useable archive which will allow future research of the evidence to be undertaken.

2.2 Specific objectives

2.2.1 The specific project objectives applied to land parcels 24-29 were as follows:

- xiii. To conduct the programme of archaeological investigation within the general research parameters and objectives defined by the revised East of England Research Framework (Medlycott 2011);
- xiv. To clarify whether the cropmarks provide an accurate representation of the range, quantity and types of archaeological features present within the site, and whether changing geology has obscured evidence of features in some areas;
- xv. To investigate the evidence for activity carried out in the landscape surrounding burial monuments of the Neolithic and early Bronze Age periods, and establish its frequency and character;
- xvi. To clarify whether the small circular ring ditch is the remains of a house enclosure, or is a monument of the later Bronze Age, and if the latter, to establish its date and duration of use within and beyond the period;
- xvii. To establish whether settlement activity of the later Bronze Age or Iron Age is present on the site, and its chronological relationship to the ring ditch within the site;
- xviii. To establish whether Roman activity is present within the site, and if so, whether this takes the form of settlement, farming or activity of other kinds, and establish their duration within the Roman period;
- xix. For the early medieval period, to determine whether Anglo-Saxon pits, sunken featured buildings and/or other buildings are present within the site, and to determine the extent, density, character and status of the settlement activity, and its relationship to activity within the Orsett Cropmark Complex to the north;
- xx. To establish the character and date of the large number of pits across the land parcel, and to determine whether these are all of one type or period, or whether they encompass several types and/or span several periods of activity;
- xxi. To establish the date of the possible medieval or post-medieval field boundaries that have been identified within the land parcel;
- xxii. To establish the presence or absence of possible medieval droveways or trackways aligned through the land parcel;
- xxiii. To establish the presence or absence of medieval and post-medieval farmsteads which may have been located within the land parcel.

3 Methodology

3.1 Constraints

- 3.1.1 The principal constraints that required consideration when these trenches were positioned was a set of overhead pylons that bisected Land Parcels 28 and 29 and a public footpath that crossed Land Parcel 26. In addition, there were extant buildings and fence boundaries. Each trench was positioned to avoid unnecessary impact or damage to these structures.

3.2 Methodology for the evaluation

- 3.2.1 The total area originally available for evaluation as stated in the WSI was 28.81ha. The area available for investigation, excluding areas of services, hedgerows, and other constraints, was c 18.4ha. The accessible archaeological trial trenching comprised a total of 145 trenches, most measuring 30m x 2m, but a few measuring a little more or less than this. Four trenches (Trenches 21, 58, 59 and 78) comprised larger open areas designed to allow for a more detailed investigation of particular cropmarks. Trench 27 was separated into two shorter lengths of trench, targeted to investigate two parts of a cropmark suggestive of an enclosure ditch. Together the excavated trenches represented a c 5% sample of the area available for trenching. The location of the excavated trenches is shown on Figure 2.
- 3.2.2 The trench design was developed to target cropmark features identified by the aerial mapping report (Place Services 2019), and otherwise to provide even coverage of the blank areas (Fig. 2).
- 3.2.3 All trenches were located using a Global Positioning System (GPS) prior to machine excavation. All trenches were excavated using a tracked excavator fitted with a toothless bucket operated under constant archaeological supervision.
- 3.2.4 Revealed features were hand cleaned and sampled by hand excavation. They were recorded as outlined in the approved WSI. All finds were bagged by context throughout the evaluation and were recovered for further investigation.
- 3.2.5 Trenches 5 to 15, 69, 86 and 89 could not be accessed at the time of this investigation.

4 Results

4.1 Introduction and presentation of results

- 4.1.1 The results of the evaluation are presented below and include a stratigraphic description of the trenches that contained archaeological remains. The full details of all trenches with dimensions and depths of all deposits can be found in Appendix A. Finds data and dates are presented in Appendix B with the environmental report presented in Appendix C.
- 4.1.2 Context numbers reflect the trench numbers, unless otherwise stated. The first numerals of a context number repeat the trench number whilst allowing for a maximum range of 100 individual records for any one trench. For example, ditch 103 is a cut within Trench 1, while pit 7815 is a cut within Trench 78. Also Trench 1 has a potential record number range of 100-199, while Trench 78 has a range of 7800-7899.
- 4.1.3 The overall pattern of the recorded cropmarks is shown on Figure 2 along with the trench layout for the site. Detailed plans of the trenches containing archaeological features are shown on Figures 3-15 (odd numbers) and Figures 18-28 (even numbers). Selected sections are shown on Figures 4-14 (even numbers), Figures 16 and 17 and Figures 19-29 (odd numbers).

4.2 General soils and ground conditions

- 4.2.1 The soil sequence across the site was fairly uniform with a natural geology of either light reddish-brown sandy gravel, reddish-brown sandy clay, or yellowish orange silty sand. The natural that was encountered is the superficial deposits of the Boyn Hill Sand and Gravel, which covers the Lambeth Group clay, silt and sand deposits in this area.
- 4.2.2 A subsoil layer (generally 0.1–0.3m thick) of reddish-brown sandy silt was encountered in most trenches and this overlay the natural geology. This may be the relict remains of a former ploughsoil which has been eroded, probably by the modern ploughing. The subsoil and natural was overlain by a topsoil/ploughsoil which was a greyish brown sandy silt or silty sand that was 0.2-0.4m thick.
- 4.2.3 Ground conditions throughout the evaluation were generally good and archaeological features and deposits were easily identifiable. Natural features and deposits were also easily recognisable at surface level, although several were sample-excavated to confirm initial interpretations.

4.3 General distribution of archaeological deposits

- 4.3.1 Archaeological features were recorded in Trenches 1, 17, 19, 20, 21, 23-29, 35, 36, 51, 52, 57, 59-63, 71-74, 78-81, 92-96, 99, 103, 106, 111, 113, 120, 121, 123, 129, 130, 133, 137-140, 142, 146-154 and 156.
- 4.3.2 The evaluation confirmed the existence of the linear and discrete features identified as cropmarks within Land Parcel 28 (Place Services 2019). Elsewhere, archaeological features were fairly evenly distributed within Land Parcels 25 and 29. Archaeological features were less prevalent in Land Parcel 26 and none was identified within Land Parcel 28, west of the overhead pylon constraint.

Archaeological features were present in the majority of the trenches in Land Parcel 24 but there were only a small number per trench.

- 4.3.3 Of the 80 interventions dug to the base of linear features, 51 were no more than 0.20m deep, and a further 25 no deeper than 0.40m. The predominately shallow depth of these and other features suggests that some degree of truncation has occurred on the site, most probably the result of modern ploughing.

4.4 Land Parcel 24: Trenches 16-17, 19-21, 23-24 and 25-29 (Figs 3-8)

- 4.4.1 **Trench 16** was located at the far western end of Land Parcel 24 and contained a ditch (1603, Section 1600, Fig. 4). The ditch measured 0.92m wide and 0.4m deep and contained a single sterile grey-brown sandy silt fill (1604).
- 4.4.2 **Trench 17** was located at the western end of Land Parcel 24, to the east of Trench 16. It revealed a N-S aligned ditch (1703), which measured 0.3m wide and 0.1m deep and contained a single sterile fill (1704). The trench also revealed a possible tree throw hole (1705), which extended beyond the eastern edge of the trench. The fill (1706) contained two fragments of amorphous fired clay. Environmental sample 7, taken from the fill, contained further fragments of fired clay, as well as abundant charcoal, fragments of which were identified as oak.
- 4.4.3 **Trench 19** was located to the east of Trench 17 and to the south of Trench 18. It revealed a single pit (1903, Section 199, Fig. 4). The pit was circular in shape and measured 0.48m wide and 0.1m deep. It contained a single brownish grey sandy clay fill (1904) that contained 33 sherds of late Bronze Age pottery, two fragments of amorphous fired clay, and a fragment of animal bone. Sample 9 from this fill was not productive, containing only a single cereal grain, possibly oat. This fill also contained three flint bladelet pieces derived from trimming.
- 4.4.4 **Trench 20** was located to the east of Trench 19 and to the west of Trench 21. It revealed a single NE-SW-aligned ditch terminus (2003) which measured 0.84m wide and 0.2m deep. It contained a single sterile mottled grey-brown clay silt fill (1904).
- 4.4.5 **Trench 21** was located to the east of Trench 20 and to the south of Trench 22. It revealed a curvilinear ditch or ring ditch (2103), Section 2100, Fig. 6) on the northern edge of the trench. The ditch appeared to enclose a space 2.6m in diameter and extended beyond the northern edge of the trench. It measured 0.84m wide and 0.18m deep and contained a single grey-brown silty clay fill (2104) which contained nine sherds of pottery of middle Bronze Age to early Iron Age date and a fragment of amorphous fired clay.
- 4.4.6 **Trench 23** was located close to the northern edge of Land Parcel 24. It partially revealed a single pit (2303, Section 2300, Fig. 6) which measured 0.68m wide and 0.5m deep. It contained two fills, the earliest (2304) being a thin layer of sterile light grey-brown sandy silt overlain by a red-brown slightly sandy clay-silt (2305), which contained a single sherd of pottery of Iron Age date.
- 4.4.7 **Trench 24** was located to the south-east of Trench 23 and to the north of Trench 25. It revealed two postholes at its north-east end (2403 and 2405, Section 2400, Fig. 6). Posthole 2403 was circular and measured 0.26m wide and 0.18m deep and was filled by a single yellow-brown silt-clay with occasional charcoal flecks (2404). Posthole 2405 was sub-oval in shape and measured 0.41m wide and

0.57m deep. It was filled by an orange-yellow silt-clay with a dark charcoal post-pipe stain (2406). There were no finds recovered from either posthole.

- 4.4.8 **Trench 25** was located to the south of Trench 24 and to the east of Trench 21. It revealed a NE-SW aligned ditch (2507), two ring ditches (2503 and 2514) and four isolated features of unclear function (possibly natural) and one pit (2505).
- 4.4.9 Ditch 2507 (Section 2502, Fig. 6) was located in the western part of the trench. It measured 0.67m wide and 0.37m deep and was filled with a single brown grey clay silt (2508), which contained a single sherd of middle Bronze Age to early Iron Age pottery and a single sherd of broad Roman date. In the central part of the trench were two oval features. Pit 2505 was located at the north-east edge and measured 0.82m wide and 0.18m deep. It was filled with a single dark grey silt (2506) with charcoal flecks, which contained a flint flake core of possible late prehistoric type. To the south-west, oval feature 2511 was 0.7m wide and very shallow (0.1m deep) and contained a grey silty fill (2512) and was probably a natural feature. To the south-east of these features was a very irregular cut, possibly a tree throw hole (2513). Its fill (2514) contained two sherds of pottery of Iron Age date and a flint flake of possible late prehistoric date was recovered from the surface.
- 4.4.10 At the south-eastern end of the trench were two small ring ditches. The westernmost feature (2503, Section 2500, Fig. 6) enclosed a small area 1.62m in diameter. The ditch measured 0.84m wide and 0.13m deep and contained a homogeneous dark grey slightly sandy clay silt (2504). Another very similar ring ditch (2514) was partially revealed to the east. This one was not excavated but the fill was very similar in appearance. Another small oval feature (2509) was situated to the north of ring ditch 2514. It measured 0.62m wide and 0.1m deep and contained a single homogeneous mid grey clay silt fill (2510). Its function was unclear, but it may have been a natural feature. Feature 2513 was also unexcavated and appears to be in an areas of natural disturbance.
- 4.4.11 **Trench 26** was located to the south of Trench 25 and between trenches 28 and 29. It revealed a single pit (2605) and two natural features.
- 4.4.12 Pit 2605 (Section 2600, Fig. 8) was partially revealed by the trench and measured 0.72m wide and 0.28m deep. It contained two brownish grey silty clay fills (2606 and 2607), the latter (2607) of which contained seven fragments fired clay (daub). Sample 8 from this fill contained a small quantity of charred material, including wheat, as well as small fragments of fired clay. Two sub-circular natural features (2603 and 2604) were located to its east.
- 4.4.13 **Trench 27** was split into two parts across a cropmark potential enclosure boundary, which was also targeted by Trench 28 to the south. No ditches were revealed by the trenches. In the northernmost segment of Trench 27, a posthole (2703) was revealed, cutting through a natural feature (2711). The posthole measured 0.5m wide and 0.18m deep and was filled with a single brown slightly sandy silt fill (2706) which contained one sherd of pottery of middle Bronze Age to middle Iron Age date. Another natural feature (2710) was recorded in the south-eastern part of the trench, a single flint flake of possible late prehistoric date was recovered from it. In the second segment of Trench 27, only natural features (2704 and 2705) were recorded.

- 4.4.14 **Trench 28** was located to the south-west of Trench 27 and revealed a single ditch (2803) in the north-western part of the trench. The ditch was aligned NNE-SSW and measured 1.26m wide and 0.36m deep. It contained a single orange-brown silty clay fill (2804) which contained a worked flint flake of later prehistoric date.
- 4.4.15 **Trench 29** was located to the west of Trench 26. It revealed a single ditch terminus. Ditch 2904 continued beyond the eastern edge of the trench and measured 0.6m wide and 0.14m deep. It contained a single yellow-orange silty clay fill (2905) devoid of artefacts. A single fragment of tap slag was recovered from the subsoil in this trench.

4.5 Land Parcel 25: Trenches 1-3 (Figs 9 and 10)

- 4.5.1 **Trench 1** revealed two ditches (103 and 105) and a natural feature (107).
- 4.5.2 Ditch 103 (Section 100, Fig. 10) was broadly east-west aligned with a shallow concave profile. It contained a single deposit of naturally accumulated clay silt (104).
- 4.5.3 Ditch 105 (Section 101, Fig. 10) had a similar profile and fill, but was orientated NE-SW, and terminated at the west end within the trench.
- 4.5.4 Feature 107 (Section 102, Fig. 10) had a slightly irregular, curvilinear shape in plan that extended beyond the western limit of the trench. It measured just 0.04m deep and contained a single fill (108). The form of this feature indicates that it was probably a tree-throw hole.
- 4.5.5 **Trench 2** revealed an irregular and NW-SE aligned feature (203). It measured 0.89m wide, 0.28m deep and contained a single sterile fill (204). The feature is probably of natural origin.
- 4.5.6 **Trench 3** south of Trench 2 contained only a single sub-circular tree-throw hole (303), which did not contain finds.

4.6 Land Parcel 26: Trenches 35 and 36 (Figs 11 and 12)

- 4.6.1 **Trench 35** revealed a NE-SW aligned ditch (3503). The ditch measured 0.64m wide, 0.33m deep and contained a single, sterile fill (3504).
- 4.6.2 The ditch corresponds closely with a field boundary depicted on the c 1897 Ordnance Survey map.
- 4.6.3 **Trench 36** revealed a NW-SE aligned ditch (3603).
- 4.6.4 The ditch (Section 3600, Fig. 12) measured 1.24m wide, 0.30m deep and contained a single fill (3604). This ditch does not appear to have continued southwards very far, as it was not picked up in Trenches 38 or 46 to the south. As it was roughly at right angles to ditch 3503 in Trench 35, it may have been related to it and ended at the projected line of that ditch.
- 4.6.5 **Trench 46.** A discrete sub-circular soilmark (4603) was found towards the east end of this trench, and this was investigated, but was found to be irregular and of natural origin.

4.7 Land Parcel 28 west (Figs 13 and 14)

- 4.7.1 **Trench 51** revealed the southern terminus of a north-south aligned ditch (5103). It measured 0.80m wide, 0.28m deep and contained a single fill (5104) but no

finds. An irregular linear soilmark to the east (5105) was also investigated but proved to be of natural origin.

- 4.7.2 **Trench 52** lay east of Trench 51 and was positioned to cross the intersection of two linear cropmarks and a third linear cropmark, together with a discrete cropmark feature. Trench 52 revealed three ditches (5205, 5207 and 5209) and a pit (5203), all corresponding with the cropmark features, although there was a slight offset between the plotted cropmarks and the actual features below ground. None of these features contained finds.
- 4.7.3 Ditch 5205 (Section 5201, Fig. 14) was the eastern of two parallel and NW-SE aligned ditches. It measured 1.04m wide, 0.20m deep and contained a single fill (5206).
- 4.7.4 Ditch 5207 (Section 5202, Fig. 14) ran parallel and c 3.7m to the west of ditch 5205. The ditch measured 0.70m wide, 0.20m deep and had a single fill (5208).
- 4.7.5 Ditch 5209 (Section 5202, Fig. 14) was cut by ditch 5207 and was on an WNW-ESE alignment. It measured 0.90m wide, 0.10m deep and contained a single fill (5210).
- 4.7.6 Circular pit 5203 (Section 5200, Fig. 14) measured 1.30m in diameter and 0.30m deep. It had sloping sides and a flattish base and contained a single fill (5204).
- 4.7.7 **Trench 61** revealed an east-west aligned ditch (6104) and a natural feature (6103), both of which corresponded with cropmarks.
- 4.7.8 Ditch 6104 measured 0.94m wide, 0.26m deep and contained a single fill (6105). The ditch continued in Trench 62 as ditch 6213.
- 4.7.9 **Trench 62** was orientated NE-SW, and was positioned to cross four cropmark linear features. Two of these were continuations of cropmarks in Trench 52 (recorded in two interventions, 5205 and 5209) to the north-west, but neither cropmark corresponded to an archaeological feature in Trench 62. Two ditches (6207 and 6213), however, did correspond to cropmarks. Two pits (6203 and 6205), two postholes (6209 and 6211) and a natural feature (6215) were also recorded, but these did not correspond to cropmarks. None of the features contained finds.
- 4.7.10 East-west aligned ditch 6213 (Section 6205, Fig. 14) corresponded with a linear cropmark and was also revealed to the east in Trench 61 (see 6104). The ditch measured 0.68m wide, 0.24m deep and contained a single fill (6214).
- 4.7.11 Ditch 6207 (Section 6202, Fig. 14) corresponded closely with a NW-SE aligned cropmark (see also 7305). The ditch measured 0.76m wide, 0.16m deep and contained a single fill (6208).
- 4.7.12 Pit 6203, whose shape was somewhat irregular, measured 0.58m wide, 0.14m deep and contained a single, sterile fill (6204).
- 4.7.13 Ovoid pit 6205 measured 1.30m across, 0.34m deep and contained a single fill (6206) similar to that of natural feature 6215.
- 4.7.14 Circular postholes 6209 and 6211 were located adjacent to each other between the two ditches and measured 0.20m and 0.25m in diameter and 0.13m and 0.08m deep respectively. Each contained a single fill without finds (6210 and 6212).

- 4.7.15 **Trench 63** lay west of Trench 62, and was positioned to cross two parallel linear cropmarks on a NNW-SSE alignment. It revealed two ditches (6303 and 6305), which corresponding with the parallel linear cropmarks (see also 7203, 8106 and 8108), and two natural features (6307 and 6308).
- 4.7.16 Ditch 6303 (Section 6300, Fig. 14) measured 0.84m wide, 0.22m deep and contained a single fill (6204) but no finds. A ditch on the same line (7203) was found beyond the end of the cropmark in Trench 72 and was probably a continuation of this.
- 4.7.17 Ditch 6305 (Section 6301, Fig. 14), located to the east of ditch 6303, measured 0.57m wide, 0.11m deep and contained a single sterile fill (6306). It did not correspond exactly with the cropmark, being offset slightly to the east, but its orientation and size suggest that it represents the same feature.
- 4.7.18 **Trench 71** lay further south-west, and revealed a ditch (7107) and two postholes (7103 and 7105), none of which were visible as cropmarks.
- 4.7.19 North-south aligned ditch 7107 (Plate 1) lay at the east end of the trench. It measured 0.70m wide, 0.28m deep and contained a single fill (7108). An environmental sample (sample 5) taken from the fill produced a limited flot that contained several hazelnut shell fragments, a small amount of probable wheat grain in poor condition, together with sedge seeds and charred goosefoot seeds. There were no other finds.
- 4.7.20 Circular postholes or stakeholes 7103 and 7105 were located adjacent to each other. They measured 0.21m and 0.24m in diameter and 0.32m and 0.22m deep, respectively. Each had a pointed base, suggesting that the stakes or posts had been driven into the ground. An environmental sample (sample 4) taken from the fill (7104) of posthole 7103 produced a poor flot containing charcoal and clinker-like material.
- 4.7.21 **Trench 72** revealed two ditches (7203 and 7205) and a natural feature (7207) that was cut by the earlier ditch 7205.
- 4.7.22 Ditch 7205 (Section 7201, Fig. 14) was aligned NE-SW and terminated within later ditch 7203 at its south-west end. Ditch 7205 measured 0.47m wide, 0.40m deep and contained a single fill (7206), from which two sherds of Iron Age pottery were recovered.
- 4.7.23 Ditch 7203 (Section 7201, Fig. 14) was orientated NNW-SSE, and cut across the end of ditch 7205. It measured 0.71m wide and 0.46m deep and contained a single sterile fill (7204). This ditch is in line with a NNW-SSE orientated cropmark exposed as ditch 6207 to the north (see above), and although the cropmark did not extend this far south, it is probably a continuation of the same ditch.
- 4.7.24 **Trench 73** lay east of Trench 72 and was positioned across two parallel linear cropmarks aligned NNW-SSE. It revealed two ditches (7303 and 7305) corresponding to the cropmarks.
- 4.7.25 The western ditch (7305) measured 0.52m wide, 0.11m deep and contained a single fill (7306). It belongs to the same ditch as cut 6207 to the north. Shallow ditch 7303 measured 0.64m wide but only survived 0.08m deep. Neither contained finds.

4.8 Land Parcel 28 east (Figs 15-17)

- 4.8.1 **Trench 57** lay in an area without cropmarks on the north-east edge of the site, and revealed three shallow ditches (5703, 5705 and 5707) and an unexcavated ditch or pit (5709).
- 4.8.2 The westernmost ditch (5703) was rather sinuous but otherwise aligned approximately north-south. The ditch (Section 5700, Fig. 16) measured 0.70m wide, 0.14m deep and contained a single, sterile fill (5704).
- 4.8.3 Ditch 5705 (Section 5701, Fig. 16) was aligned N-S, but bowed slightly to the east, making it slightly curvilinear. It measured 0.46m wide, 0.22m deep and contained a single fill (5706) without finds. This ditch did not continue southwards into Trench 58, and it is possible that rather than being a linear boundary, this and ditch 5703 formed a small curvilinear enclosure.
- 4.8.4 **Trench 59** was a rectangular trench measuring approximately 13.5m x 8.5m, positioned into investigate a complex of cropmark features comprising a N-S and an E-W linear intersection, and two of a line of three elongated pits aligned roughly N-S, together with a further discrete cropmark. No ditch corresponding to the N-S continuous linear cropmark was found, but the trench did reveal features corresponding to the east-west ditch (5903), one of the elongated pits (5905), and the discrete cropmark (pit 5907), together with two other soilmarks (5909 and 5910) that were not investigated.
- 4.8.5 Ditch 5905 was slightly offset from the approximately E-W linear cropmark, but clearly corresponded to it. The ditch (Section 5901, Fig. 16) was V-shaped in profile, measuring 0.45m wide, 0.30m deep. It contained a single, sterile fill (5906).
- 4.8.6 North-south aligned ditch 5903 was in two parts, intersecting with ditch 5905 at the north end, and then being obscured by unexcavated pit 5909. The ditch continued to the south of the pit, extending for a further 5m before appearing to terminate. A cropmark N-S linear feature continued south from this point, but ditch 5905 was not seen to continue in the trench excavation. The southern part of the ditch was investigated by hand, and measured 0.75m wide, 0.18m deep and contained a single fill (5904).
- 4.8.7 Ovoid pit 5907 corresponded closely with a discrete cropmark. The pit (Section 5902, Fig. 16) measured 2.0m in length, 1.6m wide and 0.68m deep. It had steeply sloping sides and a flat base and contained a single fill (5908). Charcoal flecking was noted in the fill and an environmental sample (Sample 1) taken from it contains charcoal together with a small number of burrowing snails. There were no other finds.
- 4.8.8 **Trench 60** lay west of Trench 59 and was located to investigate the gap between two roughly east-west cropmark linear features recorded in Trenches 59 (5905) and Trench 61 (6104), and a very large discrete cropmark feature at the north end. The trench revealed two probable ditches (6003 and 6005) and a natural feature (6006). A variation in the natural geology was noted to correspond to the large cropmark at the northern end of the trench.
- 4.8.9 Feature 6003 (Section 6000, Fig. 16, and Plate 2) corresponded with a NW-SE-aligned discrete cropmark. It measured 0.65m wide, 0.35m deep with steep sides

and a rounded narrow base, and contained two fills (6004 and 6008), neither of which contained finds.

- 4.8.10 Ditch 6005 (Section 6001, Fig. 16) was curvilinear, and measured 0.67m wide and 0.23m deep. It contained a single fill but no finds. This feature coincided with the position of a small discrete cropmark but was not on the same orientation. The curvilinear gully could conceivably have formed the west side of a small ring ditch up to 6m in diameter, although too little of it was exposed to confirm this.
- 4.8.11 **Trench 74** lay south-west of Trench 59 and north-west of the cropmark ring ditch in Trench 78. It was targeted upon short linear and discrete cropmarks, only one of which proved to correspond to archaeological features (pits 7409 and 7411). The trench also revealed a ditch (7403), a pit (7416) and three postholes (7405, 7407 and 7415), none of which contained any finds.
- 4.8.12 Ditch 7403 was aligned NW-SW and its north-west end lay within the trench. It measured 0.60m wide, 0.34m deep and contained a single sterile fill (7404).
- 4.8.13 Sub-circular pits 7409 and 7411 both corresponded with a discrete pit-like cropmark. Originally thought to represent a single linear feature, two separate elements were recognized during excavation, though the relationship between the two pits was not determined. The southern element (pit 7411) measured 1.70m across and 0.60m deep and contained two fills (7412 and 7413) (Section 7404, Fig. 10). Pit 7409 measured 1.36m across, 0.68m deep and contained a single fill (7410). It is possible that the pits were quarries for sand and gravel of relatively recent date.
- 4.8.14 Circular posthole 7405 measured 0.70m in diameter, 0.48m deep and contained a single fill. Its size suggest it supported a substantial post.
- 4.8.15 Circular posthole 7407 (Section 7402, Fig. 16, and Plate 3), located 5.2m to its south-east, was also substantial, measuring 0.68m in diameter and 0.36m deep. It contained a single fill (7408). A further unexcavated posthole (7415) was possibly also associated. These postholes may all have belonged to a structure west of pits 7409/7411.
- 4.8.16 **Trench 78** formed a rectangular area measuring c 13m x 8m, which was positioned to investigate a complex of cropmarks. A possible ring ditch (7809/7813), three ditches (7805, 7807 and 7817), three pits (7803, 7815, and 7819) and two postholes (7811 and 7818) were revealed (Plate 4).
- 4.8.17 The curving ditch corresponded closely with the cropmark ring ditch, suggesting an overall external diameter of c 13m. The ditch (7809/7813) was investigated in two slots (Sections 7803 and 7805, Fig 17 and Plate 5) revealing it to be 1.14m wide and up to 0.46m deep. The ditch contained a single fill (7810/7814) from which 52 sherds (507g) of pottery from a single vessel was recovered. The vessel can only be broadly dated to the middle Bronze Age to early Iron Age, although the latter date is perhaps more likely. A flint flake was also recovered from fill 7810 along with a small modern iron nail, the latter clearly intrusive. An environmental sample (Sample 2) taken from fill 7810 produced a poor flot consisting of charcoal and indeterminate charred material.
- 4.8.18 Ditch 7807 corresponded closely with a linear and approximately north-south-aligned cropmark. The ditch (Section 7802, Fig. 17) measured 0.74m wide, 0.30m deep and contained a single fill (7808) from which a sherd of pottery broadly dated to the middle Bronze Age to the early Iron Age was recovered.

- 4.8.19 According to a sketch made on site, ditch 7807 may have cut the fill of the ring ditch and terminated c 0.25m into its fill, but this was not certain, and was not confirmed by excavation. Alternatively, a small projection on the inside of the ring ditch in line with ditch 7807, which was numbered 7818, could represent its terminus, but the relationship between the ring ditch and ditch 7807 remains uncertain.
- 4.8.20 Narrow ditch 7805 was orientated NW-SE and was probably cut by pit 7803 on the south side. It measured 0.36m wide and 0.08m deep and contained a single fill (7806) from which two sherds of Iron Age pottery were recovered. A ditch on approximately the same alignment and line was exposed in Trench 94 to the south (see Fig. 18, ditch 9406).
- 4.8.21 Pit 7803 possibly cut ditch 7805. The pit measured at least 1.0m across and 0.40m deep and contained a single fill (7804). This may have been the edge of unexcavated feature, 7819, a large pit measuring at least 7.3m across that corresponded with a cropmark within the southern part of the trench.
- 4.8.22 Sub-circular pit 7815 cut ring ditch 7813 (Section 7805, Fig. 17). The pit measured 1.54m across, 0.33m deep and contained a single fill (7816). An abraded sherd of Iron Age pottery was recovered from the fill.
- 4.8.23 Circular posthole 7811 was located within the ring ditch. It measured 0.40m in diameter, 0.15m deep and contained a single charcoal-rich fill (7804). An environmental sample (sample 3) taken from the fill produced a poor flint consisting of small charcoal fragments.
- 4.8.24 A second possible posthole (7817) located nearby but outside the ring ditch, may have been related, but was not excavated.
- 4.8.25 **Trench 79** lay south-west of Trench 78 in an area of scattered discrete cropmarks. It revealed three parallel and NW-SE aligned ditches (7905, 7907 and 7909).
- 4.8.26 The westernmost ditch (7909) measured 1.45m wide, 0.29m deep and contained a single fill (7910) but no finds (Section 7901, Fig. 17, and Plate 6).
- 4.8.27 Ditch 7907 (Plate 6) ran parallel just to the east of ditch 7909, but the ditches did not intercut (Section 7901, Fig. 17). It measured 1.34m wide, 0.30m deep and contained a single fill (7908), from which an amorphous lump of fired clay was recovered. The ditch is on the same line as narrower ditch terminus, 7403, in Trench 74 to the north. Neither ditch was detected in the trenches to the south (see Fig. 18).
- 4.8.28 The easternmost ditch (7905) terminated with a bulbous north-west end within the trench. The ditch measured 1.10m wide, 0.17m deep and contained a single fill (7906), but no finds. No continuation was seen in the trenches to the south.
- 4.8.29 **Trench 95** lay south-east of Trench 78 and was positioned to cross two parallel linear cropmarks aligned NE-SW some 11m apart, and a very large feature north of these. Trench 95 revealed four NE-SW-aligned ditches (9503, 9505, 9506 and 9507), two of which corresponded to the linear cropmarks (9505 and 9507), and a large pit-like feature corresponding to the large cropmark.
- 4.8.30 Three of the ditches (9505-7), including both of those corresponding to the cropmarks, were not excavated, as they had already been hand-excavated in Trench 96. Ditch 9503, however, which lay mid-way between the two cropmark

linear ditches, was investigated, and found to measure 0.80m wide and 0.18m deep and contain a single, sterile fill (9504).

- 4.8.31 The large feature exposed at the north end of the trench was judged to be natural in origin and was not further investigated.
- 4.8.32 **Trench 96** was parallel to, and to the east of, Trench 95, and was also located to cross the same cropmark linear ditches. It revealed three NE-SW aligned ditches (9603, 9605 and 9607) and a pit or ditch (9609) that was not excavated. Two of the ditches (9603 and 9605) corresponded closely with the parallel linear cropmarks.
- 4.8.33 The northern cropmark ditch (9603) was significantly wider than the cropmark (Section 9000, Fig. 17). The feature measured 2.40m wide, 0.24m deep and contained a single fill (9604) but no finds. Its wide flat base could suggest that the feature was a trackway or holloway rather than a ditch.
- 4.8.34 The corresponding southern cropmark ditch (9605) measured 1.30m wide, 0.35m deep and had a more typical ditch profile (Section 9601, Fig. 17), being 1.30m wide and 0.36m deep. It contained a single fill (9606), but again no finds.
- 4.8.35 A third parallel ditch lay some 4.5m further south in both Trenches 95 and 96. In Trench 96, this ditch (9607) measured 1.0m wide and 0.20m deep and had a single, sterile fill (9608).
- 4.8.36 The unexcavated feature 9609 lay between the cropmark ditches, closer to 9603, and was a large soilmark some 3m across.

4.9 Land Parcel 28 south (Figs 18 and 19)

- 4.9.1 **Trench 80** lay south-west of Trench 79 in an area without cropmarks. Trench 80 revealed three ditches (8003, 8005 and 8007), together with two natural features.
- 4.9.2 The southernmost ditch (8003) was orientated WSW-ENE, measured 1.10m wide and 0.26m deep and contained a single fill (8004) without finds (Section 8000, Fig. 19, and Plate 7). The ditch was on a similar alignment to, but 4-5m north of, the line of a linear cropmark located to the east (see ditches 9507 and 9603).
- 4.9.3 The central ditch (8005) was aligned NE-SW and measured 0.85m wide and 0.14m deep and had a single sterile fill (8006).
- 4.9.4 The northern ditch (8007) was aligned WSW-ENE, measured 0.45m wide, 0.08m deep and contained a single fill (8008), also without finds.
- 4.9.5 **Trench 81** lay to the west of Trench 80 at right angles to it, and revealed two parallel ditches (8106 and 8108) aligned NNW-SSE, as well as an isolated posthole (8103).
- 4.9.6 The larger ditch (8106) lay in the centre of the trench and measured 1.24m wide, 0.42m deep (Section 8101, Fig. 19, and Plate 8). It had a single fill (8107) that was without finds. It was probably a continuation of ditch 7203 in Trench 72 to the north, with which it was in line. This ditch continues the line southwards of the western of two parallel cropmarks (see Fig. 13).
- 4.9.7 The other ditch (8108) lay further east and measured 0.74m wide and 0.26m deep. It also contained a single sterile fill (8109). The ditch follows the line of the eastern of the two parallel cropmarks (see Fig. 13, ditch 6305).

- 4.9.8 Circular posthole 8103 (Section 8100, Fig. 19) measured 0.24m wide and 0.18m deep. It contained two fills (8104 and 8105), one of them (8104) being a postpipe (8104) that contained frequent charcoal. No finds were present.
- 4.9.9 **Trench 92** lay south of Trench 80. It revealed a posthole (9203) and a natural feature (9206).
- 4.9.10 Circular posthole 9203 measured 0.43m in diameter and 0.22m deep (Section 9200, Fig. 19). It contained two fills, one (9205), which contained flecks of charcoal, representing a postpipe, the other (9204) being the fill. Neither contained finds.
- 4.9.11 **Trench 93** revealed three narrow ditches (9305, 9308 and 9312), two pits (9303 and 9310), and two natural features (9304 and 9307).
- 4.9.12 The northmost ditch (9305, Plate 9) was orientated WNW-ESE, and was 0.80m wide and 0.23m deep. It contained a single fill (9306) from which several burnt flints were recovered. An environmental sample (Sample 6) taken from the fill produced a limited flot comprising a moderate quantity of charcoal, poorly preserved probable wheat grain, and a mix of charred and modern goosefoot seeds.
- 4.9.13 The middle ditch (9312) (Section 9302, Fig. 19) was orientated approximately ENE-WSW and may have terminated against the west side of the trench. The ditch measured 0.38m wide, 0.46m deep and contained a single sterile fill (9313). The ditch approximately followed the line westwards of a ditch mid-way between two parallel linear cropmarks (see ditch 9503 in Trench 95).
- 4.9.14 The southernmost ditch (9308) was aligned approximately with the southern of the two parallel cropmarks to the east (see ditches 9505 and 9605). The ditch measured 0.74m wide, 0.11m deep and contained a single fill (9309). There were no finds.
- 4.9.15 Oval pit 9310, which cut ditch 9312 (Section 9302, Fig. 19), measured 0.52m across and 0.34m deep and had a single sterile fill (9311).
- 4.9.16 **Trench 94** revealed two parallel and approximately NW-SE-aligned ditches (9404 and 9406) and a natural feature (9403).
- 4.9.17 The western ditch (9404) (Section 9400, Fig. 19) measured 1.04m wide, 0.16m deep and contained single sterile fill (9405).
- 4.9.18 Ditch (9406) was located approximately 2.8m to the east. The ditch measured 1.04m wide, 0.16m deep and contained a single sterile fill (9407). A ditch on much the same alignment was seen in Trench 78 to the north (see Fig. 16 ditch 7805), though the distance between them makes it impossible to claim with confidence that these were parts of the same ditch.
- 4.9.19 **Trench 99** lay south of Trench 94, and was positioned to cross one large discrete cropmark. Trench 99 revealed a large soilmark corresponding with the position of the cropmark (9906), and also revealed a pit (9903).
- 4.9.20 The pit (Section 9900, Fig. 19, and Plate 10) was ovoid, measuring at least 2m long, 1.3m wide and 0.68m deep. It contained two fills (9904 and 9905), each containing occasional charcoal flecks.
- 4.9.21 Soilmark 9906 corresponded closely with a pit-like cropmark, and was tested by hand, but its firm orangish brown sandy silt fill suggested a geological origin.

4.10 Land Parcel 29 west (Figs 20 and 21)

- 4.10.1 **Trench 103** lay at the western edge of Land Parcel 29, and revealed two ditches (10305 and 10307), neither of which contained finds, and a tree-throw hole (10303).
- 4.10.2 Ditch 10305 (Section 10301, Fig. 21) was aligned roughly NW-SE, measuring 0.40m wide and 0.20m deep, and contained a single fill (10306).
- 4.10.3 Ditch 10307 (Section 10302, Fig. 21) lay east of ditch 10305 and was on a NNE-SSW alignment. It measured 0.60m wide, 0.12m deep and contained a single fill (10308).
- 4.10.4 **Trench 105** lay east of Trenches 103 and 104 and revealed a natural feature (10503).
- 4.10.5 **Trench 106** lay east of Trench 105 and revealed a shallow and circular pit (10603). The pit (Section 10600, Fig. 21) measured 0.60m in diameter, 0.10m deep and contained a single fill (10604), which was without finds.

4.11 Land Parcel 29 north (Figs 22 and 23)

- 4.11.1 No cropmarks were evident in this part of the site. Most of the trenches in this area were devoid of archaeological features. None of the three ditches identified contained finds.
- 4.11.2 **Trench 111** revealed a ditch (11103) aligned NW-SE. The ditch (Section 11100, Fig. 23) measured 0.64m wide, 0.10m deep and contained a single, sterile fill (11104).
- 4.11.3 **Trench 113** lay north-east of Trench 111 and revealed a ditch on an approximately NE-SW orientation (11303). The ditch measured at least 0.87m wide, 0.16m deep and contained a single fill (11304). This ditch did not continue very far, as no continuation was seen in the trenches 112 and 114 that crossed the projected line of the ditch to the west and east respectively.
- 4.11.4 **Trench 133**. Trench 133 revealed a NW-SE aligned ditch (13303). The ditch (Section 13300, Fig. 23) measured 0.73m wide, 0.10m deep and contained a single fill (13304). No continuation of this ditch was seen either in Trench 134 to the east or in Trenches 117 or 113 to the north-west.

4.12 Land Parcel 29 south-west (Figs 24 and 25)

- 4.12.1 This group of trenches lay east and south-east of Trenches 103-106 (Fig. 2). Most of the trenches in this area were blank, archaeological features being present in Trenches 123 and 142 only (Fig. 24). No finds came from these features, but struck flint was recovered from the topsoil 12300.
- 4.12.2 **Trench 123** revealed a NW-SE-aligned ditch (12303) that terminated within the trench. The ditch (Section 12300, Fig. 25) measured 0.70m wide, 0.28m deep and had a single fill (12304). No continuation of this ditch was seen in Trench 107, which crossed its line to the north-west.
- 4.12.3 **Trench 142** revealed a NE-SW aligned ditch (14203) and a tree-throw hole (14205). The ditch (Section 14200, Fig. 25), which terminated within the trench, measured 0.70m wide, 0.18m deep and contained a single fill (14204).

4.13 Land Parcel 29 south (Figs 26 and 27)

- 4.13.1 This group of trenches lay east of those shown on Figure 18, and the majority contained archaeological features (Fig. 26). Most of these were ditches that may have formed a system of fields or enclosures on a NW-SE by NE-SW or NNW-SSE by WSW-ENE alignment.
- 4.13.2 **Trench 120** revealed three ditches (12005, 12007 and 12011), two postholes (12003 and 12009) and two natural features (12013 and 12015). No finds came from any of the features in this trench.
- 4.13.3 Ditch 12005 was aligned approximately NW-SE. The ditch (Section 12001, Fig. 27) measured 0.56m wide, 0.08m deep and contained a single fill (12006).
- 4.13.4 Ditch 12007 was at right-angles to ditch 12005, joining it on the west side. This suggests that the two were contemporary, though the excavated section indicates that ditch 12007 was earlier (Section 12001, Fig. 27). Ditch 12007 measured 0.30m wide and 0.08m deep and had a single fill (12008). It is possible that ditch 12007 continued south-westwards as ditch 12103 in Trench 121, though not enough was seen in Trench 120 to be sure of its alignment.
- 4.13.5 Ditch 12011 was orientated NE-SW but was not quite parallel to ditch 12007 or perpendicular to ditch 12005. Ditch 12011 measured 0.46m wide, 0.06m deep and contained a single fill (12012).
- 4.13.6 Circular posthole 12003 (Section 12000) lay to the east of ditch 12005, measured 0.34m in diameter and 0.11m deep, and contained a single fill (12004).
- 4.13.7 Sub-oval posthole 12009 was located 3.9m to the west of posthole 12003 inside the corner formed by ditches 12005 and 12007. The posthole measured 0.5m across, 0.34m deep and contained a single fill (12010).
- 4.13.8 **Trench 121** lay west of Trench 120. It revealed an approximately NE-SW aligned ditch (12103), likely to be the continuation of ditch 12007 in Trench 120. The ditch measured 0.56m wide, 0.22m deep and contained a single fill (12104), but no finds.
- 4.13.9 **Trench 129** lay to the south-east of Trench 120, and revealed three ditches (12903, 12905 and 12907), none of which produced any finds.
- 4.13.10 Ditch 12903 (Section 12900, Fig. 27) was aligned ENE-WSW, and terminated within the trench. It measured 0.36m wide and 0.22m deep and had a single fill (12904). No continuation of this ditch was seen in Trench 128, which crossed its projected line further west.
- 4.13.11 Ditch 12905 formed the NE-SW-aligned arm of the junction of two ditches that formed a right-angled T-junction and terminated to the south-west within the trench. The ditch measured 0.15m wide, 0.10m deep and contained a single fill (12906).
- 4.13.12 The other arm of this T-junction was ditch 12907, which was orientated NNW-SSE and was of similar dimensions to ditch 12903. It was not excavated. No continuation of this ditch was seen in Trench 145 to the south.
- 4.13.13 **Trench 130** revealed a relatively substantial NNW-SSE aligned ditch (13003), most likely to be the north continuation of ditch 13804 in Trench 138.

- 4.13.14 The ditch (Section 13000, Fig. 27) measured 1.80m wide, 0.46m deep and contained a single fill (13004). A small fragment of CBM and a piece of fired clay, both of indeterminate forms, were recovered from the fill.
- 4.13.15 **Trench 138** lay south of Trench 130, and revealed a relatively substantial ditch (13804) on a NW-SE alignment, which although not precisely aligned with ditch 13003 in Trench 130, is likely to be a continuation of this same ditch, indicating that this curves to the south-east. There was also a tree-throw hole (13803).
- 4.13.16 The ditch (Section 13800, Fig. 27) measured 1.48m wide and 0.46m deep and contained a single fill (13805). A large fragment of brick, probably late medieval in date, was recovered from the fill.
- 4.13.17 **Trench 139** lay south-west of Trench 138, and revealed a firm layer of light greyish brown, clayey sand (13903). This had curving edges, suggesting a sub-circular area measuring c 7.5m across within the trench. Excavation of a small sondage into the deposit showed that here it was only 0.08m deep, but a retouched flint flake, possibly of Neolithic date, was recovered.
- 4.13.18 **Trench 140**, lying west of Trench 139, revealed a narrow ditch (14003) aligned NNW-SSE. The ditch measured 0.30m wide, 0.08m deep and contained a single sterile fill (14004).
- 4.13.19 **Trench 145**, which lay east of Trench 140, contained only a tree-throw hole 14503.
- 4.13.20 **Trench 146** lay south of Trench 138, and revealed a narrow ditch (14603) aligned approximately NE-SW. The ditch measured 0.26m wide, 0.06m deep and contained a single fill (14604). This ditch is at right angles to the larger ditch in Trenches 130 and 138, to which it may have been related. It is also roughly in line with the broader ditch 13703 in Trench 37 to the east (see Fig. 28), but they are too far apart to be confident that they were parts of one boundary.
- 4.13.21 **Trench 152** revealed a narrow NE-SW aligned ditch (15203), which measured 0.39m wide and 0.07m deep and contained a single sterile fill (15204). This ditch was in line with the larger ditch 15403 in Trench 154 some distance to the south-west and was probably part of the same boundary ditch. It was also of similar size to ditch 14603 further north, and roughly parallel to it, so they may possibly have formed part of a contemporary system of rectilinear boundaries.
- 4.13.22 **Trench 153** exposed part of a large pit, tentatively interpreted as a dew pond, that measured c 10.7m across. Two slots (15303 and 15305) were excavated into it, both revealing its depth to be 0.60m (Section 15300, Fig. 27). It contained a single fill (15304/15306) from which fragments of undiagnostic fired clay and a small quantity of burnt flint were recovered.
- 4.13.23 **Trench 154** revealed a NE-SW aligned ditch (15403), which is likely to be the continuation westwards of ditch 15203 in Trench 152. The ditch (Section 15400, Fig. 27) measured 0.90m wide and 0.14m deep and contained a single fill (15404).
- 4.13.24 **Trench 156** lay south of Trench 153, and revealed a possible ditch (15603) that ran just west of north-south along the trench. The ditch measured 0.34m wide, 0.09m deep and contained a single, sterile fill (15604).

4.14 Land Parcel 29 south-east (Figs 26, 28 and 29)

- 4.14.1 This group of trenches lay east of those in Figure 20, and except for the trenches at the south end, all the trenches revealed archaeological features, mostly ditches on NNW-SSE and ENE-WSW alignments (Figs 26 and 28).
- 4.14.2 **Trench 137** revealed three ditches (13703, 13705 and 13707) and two plough scars (not illustrated). There were no finds in any of the interventions into the ditches.
- 4.14.3 The easternmost ditch (13703) was aligned ENE-WSW. The ditch measured 0.72m wide, 0.06m deep and contained a single fill (13704).
- 4.14.4 Ditch 13705 was at right angles to ditch 13703 and measured 0.86m wide and 0.15m deep (Section 13701, Fig. 29). It had a single fill (13706) but no finds. This ditch was in line with ditch 14705 in Trench 147 to the south, which was clearly a continuation of the same feature.
- 4.14.5 West of this, narrower ditch 13707 ran on an almost parallel alignment. It measured 0.46m wide and 0.06m deep (Section 13702, Fig. 29) and contained a single fill (13708). This ditch continued in Trench 147 to the south as ditch 14703.
- 4.14.6 **Trench 147** lay south of Trench 137 and revealed two ditches on similar alignments that are probably continuations of ditches 13705 and 13707 in Trench 137, but again there were no finds recovered from them.
- 4.14.7 The eastern ditch (14705) measured 0.66m wide, 0.06m deep and contained a single fill (14706). This ditch was a continuation of ditch 13705.
- 4.14.8 The western ditch (14703) measured 0.50m wide and 0.05m deep and contained a single fill (14704). This ditch was on a very slightly more north-westerly alignment than 14705 and was aligned with ditch 13707 to the north.
- 4.14.9 **Trench 148** was situated to the east of Trench 147, and revealed a shallow pit (14803) and a posthole (14805). No finds came from either feature.
- 4.14.10 The pit (14803) was sub-circular, measuring 0.80m in diameter and 0.12m deep and contained a single fill (14804).
- 4.14.11 The posthole (14805), measured 0.38m in diameter and 0.80m deep and contained a single fill (14806).
- 4.14.12 **Trench 149** lay south-east of Trench 147, and like that trench revealed two ditches aligned NNW-SSE (14903 and 14905), although these were not aligned with the ditches further north-west. The trench also exposed an irregularly shaped small pit or posthole (14907) and a tree-throw hole (14909). No finds were recovered from any of these features.
- 4.14.13 The eastern ditch (14903) measured 1.06m wide and 0.30m deep and contained a single fill (14904) (Section 14900, Fig. 29). The projected line of this ditch probably passed just east of the end of Trench 137 to the north, so it is not known how far it continued.
- 4.14.14 The western ditch (14905) measured 0.65m wide and 0.10m deep and contained a single fill (14906) (Section 14901, Fig. 29). No continuation of this ditch was seen in Trench 137 to the north, so it presumably ended, turned before this, or narrowly missed the trench.

- 4.14.15 Small pit or posthole (14907) was an irregular oval measuring 0.50m across and 0.16m deep, with a single sterile fill (14908).
- 4.14.16 **Trench 150**, which lay west of Trench 149 and south of Trench 147, revealed a ditch (15003) on an ENE-WSW alignment and two natural features (15005 and 15006).
- 4.14.17 The ditch (Section 15000, Fig. 29) measured 0.75m wide, 0.14m deep and contained a single sterile fill (15004).
- 4.14.18 **Trench 151** lay west of Trench 150 and south of Trenches 147 and 138. It revealed a ditch (15103) aligned NNW-SSE, potentially the southward continuation of ditch 13804.
- 4.14.19 The ditch (Section 15000, Fig. 29) measured 0.80m wide and 0.28m deep and contained a single fill (15104). The fill contained a ceramic tile fragment of indeterminate date.
- 4.14.20 **Trench 152** lay west of Trench 151 and south of Trench 145. It revealed a ditch (15203), aligned ENE-WSW. The ditch measured 0.39m wide and 0.07m deep and contained a single sterile fill (15204).
- 4.14.21 **Trench 153** lay west of Trench 152 and south of Trench 144. It revealed a possible pond into which two slots were excavated (15303 and 15305). This feature measured up to c 12m in width and the two slots measured 3m and 4.6m in width respectively and measured 0.6m in depth. The possible pond contained a single sterile fill (15303/15306).
- 4.14.22 **Trench 154** lay to the west of Trench 153 and to the south of Trench 143. It revealed a ditch (15403), aligned ENE-WSW. The ditch measured 0.9m wide and 0.14m deep and with a single sterile fill (15404).
- 4.14.23 **Trench 156** lay to the south of Trench 153. It revealed a ditch (15603), aligned NNW-SSE. The ditch measured 0.34m wide and 0.09m deep and with a single sterile fill (15604).

4.15 Finds summary

- 4.15.1 **Prehistoric pottery.** Some 108 sherds (1221g) of prehistoric pottery from 12 contexts across seven trenches were recovered. The assemblage is well-preserved and includes 51 sherds (481g) from a single vessel recovered from context 7810, the fill of a ring ditch. Most of the assemblage could only be dated as later Bronze Age or early Iron Age, although there were hints that it could all belong to a single period, the early Iron Age.
- 4.15.2 **Ceramic building material.** A total of seven fragments (541g) was recovered. The material is highly fragmented and comprises two pieces of flat tile, one piece of indeterminate form and one fragment of brick. The brick fragment is late medieval or early post-medieval in date.
- 4.15.3 **Fired clay.** Sixteen fragments of fired clay (154g) were recovered, all of which are amorphous and undiagnostic.
- 4.15.4 **Worked flint.** Sixteen struck flints and five fragments of burnt unworked flint weighing 96g were recovered. They include pieces typical of the Neolithic or early Bronze Age and flakes more typical of later prehistoric flintworking.
- 4.15.5 **Metals.** A nail and a fork tine, both of iron, were recovered and are modern in date.

4.15.6 **Slag.** A single fragment of tap slag from ironworking was recovered from the subsoil.

4.16 Environmental summary

4.16.1 **Charred plant remains.** Nine bulk samples were taken. Recovery of charred material other than charcoal from these samples was limited and material from the more productive features was in poor condition.

4.16.2 **Animal bone.** A single fragment of animal bone – identified as sheep/goat – was recovered from the evaluation.

5 Discussion

5.1 Reliability of field investigation

- 5.1.1 The archaeological features were reasonably well defined and site conditions for excavation were generally good.
- 5.1.2 There was generally a good correlation between the cropmarks recorded by the aerial survey within Land Parcel 28 and the archaeological features that were revealed. Some linear cropmark features were only confirmed along parts of their length, and others had ditches that continued beyond the limits of the cropmarks. Some linear cropmark features did not, however, correspond to archaeological features below ground, most notably in Land Parcel 24, and a significant number of other features that did not appear on the cropmark plots were also identified. These were mainly smaller ditches and discrete pits.

5.2 Interpretation

- 5.2.1 **Neolithic/early Bronze Age.** No features of these periods were identified in the evaluation, and a layer of soil filling a hollow in Trench 139 is the only deposit that could be of this date, as it contained a single struck flint of Neolithic type. Otherwise, there was only one other flint tentatively attributed to these periods, and this was from topsoil in Trench 123. This suggests only very limited Neolithic or early Bronze Age activity within the vicinity of the site. One focus of activity may have been in Land Parcel 29, where early flints were recovered from two trenches.
- 5.2.2 **Later Bronze Age and Early Iron Age.** The only clearly datable activity on the site was confined to Trench 78 within Land Parcel 28 and to Trenches 19, 21, 23, 25 and 27 in Land Parcel 24.
- 5.2.3 A focus of activity of this date is represented by a small number of features in Land Parcel 24, where trenches were targeted on cropmarks identified by aerial photography. Trenches 23, 27 and 28 were targeted on a cropmark suggesting the presence of a sub-rectangular enclosure, but no trace of a corresponding ditch was found. Other cropmarks were large (c 2-6m in diameter) and sub-circular in shape and located 'within' the sub-rectangular cropmark and to the west of it, where these features appeared to be arranged in a circle, c 22m in diameter. Several of these sub-circular cropmarks were not confirmed by the evaluation, but three, in Trenches 21, 25 and 28, corresponded with the location of three small ring ditches and there was another ring ditch in Trench 25 which did not correspond with a cropmark. Those in Trenches 21 and 25 produced small amounts of pottery. Nine sherds of middle Bronze Age to early Iron Age date were recovered from ring ditch 2103 and two of Iron Age date from the surface of unexcavated ring ditch 2514. Ring ditch 2103 also contained a small amount of amorphous fired clay. Trench 23 revealed part of a sub-circular pit (2303) of Iron Age date which also corresponded with the location of a cropmark.
- 5.2.4 Other features comprised small ditches and pits and postholes, a small number of which contained datable material. In Trench 19 a pit contained 33 sherds of pottery from a fineware carinated jar comparable with late Bronze and early Iron Age vessels found in the region (see Appendix 2). A single NE-SW-aligned ditch

in Trench 25 (2507) contained one sherd of pottery of middle Bronze Age to early Iron Age date and one of broad Roman date. This may be part of one of the alignments of cropmarks and ditches recorded in Land Parcel 28 (such as 5905) or part of an unrelated enclosure.

- 5.2.5 The function of the small ring ditches in Land Parcel 24 is unclear; they are seemingly too small to represent roundhouse ring gullies but may represent other small structures. Alternatively, they may represent small funerary monuments or barrows, although there was no evidence of human burials or cremated remains associated with them.
- 5.2.6 Trench 78 (Land Parcel 28) targeted a ring ditch cropmark with a short ditch protruding from its southern side. The evaluation confirmed the presence of these features. A large part of a pottery vessel of later Bronze Age or (more likely) early Iron Age date was recovered from excavation of the ring ditch (7809). The presence of a large part of a single vessel implies either deliberate placement or discard from a house immediately adjacent. As there was no cremated bone associated, and this cannot be confirmed as a cinerary urn, it is possible that the vessel may represent a 'token' deliberate deposit. It is possible that the ring ditch have surrounded a domestic structure, but the cropmark and excavated evidence suggests that this lacks an entrance.
- 5.2.7 The ditch running south from the ring ditch (7807) contained a large sherd of pottery in a different fabric and is of middle Bronze Age to early Iron Age date. If this was related to an entrance into the ring ditch, there was no gap in the ring ditch to confirm this.
- 5.2.8 No other structures of proven later prehistoric date were found. It is possible that the curvilinear gully (6005) found some 30m to the north-west belonged to a much smaller ring ditch, but this is unproven, and was undated. Similarly, curving gullies 5703 and 5705 nearly 50m to the north may have formed part of an enclosure, but these were again undated.
- 5.2.9 **Undated.** The system of cropmark ditches on a NNW-SSE and ENE-WSW or NE-SW alignment seen in Land Parcel 28 was centered upon four roughly parallel NNW-SSE ditches tentatively interpreted as trackways. The cropmark ditch running at right angles from the southern end of the more easterly two ditches is presumably contemporary, and the pair of linear cropmarks parallel to this, and perpendicular to the east side of the trackway ditches, which were exposed in Trenches 95 and 96 together with other parallel ditches not visible as cropmarks, are also likely to be contemporary. The evaluation showed that this system was more extensive than suggested by the cropmarks, continuing further to the south and south-west. Apart from ditch 7205 with its two small Iron Age sherds, however, the system in Land Parcel 28 produced no dating evidence.
- 5.2.10 Some of the possible trackway cropmark boundaries in Land Parcel 28 are aligned with existing field boundaries; to the north the westernmost of the four trackway ditches (as revealed crossing Trenches 63 and 91) follows the line of the western side of the existing field identified as Land Parcel 26.
- 5.2.11 There was no clear continuation of this system evident in the northern part of Land Parcel 29 to the south, although the few ditches that were present there were on similar alignments, but a further concentration of ditches on these same alignments were seen in the central and southern parts of Land Parcel 29. In

Land Parcel 29, one of the largest ditches on a NNW-SSE alignment was ditch (13804) in Trench 136, from which a large brick fragment likely to date from the late medieval or early post-medieval period was recovered, and a continuation of this ditch (13003) in Trench 130 contained a fragment of undated tile. These provide a probable *terminus post quem* for the establishment of the system here.

- 5.2.12 This ditch, if projected northwards, would be aligned with the easternmost of the four NNW-SSE aligned cropmark ditches in Land Parcel 28, represented by ditches 6207 and 7305. Although the two concentrations of field systems were not continuous, they are therefore likely to have been part of a wider field system at one time. The intersecting cropmark ditches in the field west of Land Parcel 28 are also on the same alignments, and probably represent a further element of this system.
- 5.2.13 The Orsett tithe map (c 1840) shows that prior to the Ordnance Survey map of c 1870, the land to the north was apportioned into smaller fields, but Land Parcels 28 and 29 were already at the size they are today. It seems likely that the field system exposed in evaluation represent an earlier arrangement of smaller fields, which may well have had its origin in the early post-medieval or (less likely) late medieval period.
- 5.2.14 The possibility must also remain that some of the undated ditches could, despite a paucity of dating, be parts of later Bronze Age/early Iron Age field systems. A small number in Land Parcel 24 were dated by small amounts of pottery of this date and were close to other features containing late Bronze Age to early Iron Age pottery of late prehistoric worked flint such as a pit and some ring ditches. The evidence is insufficient to be certain, but it remains a possibility.
- 5.2.15 **Natural features.** The cropmark survey revealed a line of large and circular pit-like features within the northern side of Land Parcel 28 (Trenches 53, 58, 60 and 75). Given their regular alignment and spacing, these were initially interpreted as man-made in origin, perhaps World War 2 bomb craters or quarries. These were briefly tested and were shown to be natural in origin.

5.3 Evaluation objectives and results

- 5.3.1 Aims i-iii. This evaluation established the presence of archaeological remains and investigated their character through stratigraphic, artefactual and environmental evidence. The evaluation also ground-truthed the cropmark evidence as identified by the 2019 aerial survey (Place Services 2019). In addition, the evaluation investigated the apparently blank areas where no cropmarks had been identified.
- 5.3.2 Aims v and vi. With the exception of the ring ditch and a small number of features in Land Parcel 24, finds from the evaluation were scarce, and dating of the exposed features was limited. This is partly a reflection of the fact that most of the features were field or trackway ditches, indicating that most of the area was not used for settlement in the past. There were a few other trenches that hinted at further small enclosures, but these were not confirmed, nor did the interventions investigated by hand provide dating evidence. The potential of the finds to inform the status, contacts and economic character of the site appears to be low.

- 5.3.3 Aims iv, vii and viii. No areas of deep stratigraphy were encountered, nor were there any waterlogged deposits. Few deposits containing environmental remains of any kind were found, and the overall environmental potential of the area appears to be low, although some information is likely to be recoverable from the area of the ring ditch and a small number of other features.
- 5.3.4 Aims ix, x and xi. The discussion in the preceding section of this report provides an interpretation of what was found, and an indication of the archaeological potential of the site.
- 5.3.5 Aim xiii. The archaeological evaluation was conducted within the general research parameters and objectives defined by the revised East of England Research Framework (Medlycott 2011), which (with particular relevance to the results) highlight the importance of testing cropmark evidence and the proliferation of Bronze Age barrow cemeteries in parts of the region and ring ditch cemeteries such as those at Ardleigh, Brightlingsea, Little Bentley and Lodge Farm, St Osyth. Although no human remains were recovered from the evaluation, the ring ditches are in most cases not consistent with the expected size for roundhouse gullies and without 'entrances' so their potential function as funerary monuments remains. The work also took account of the aims and objectives of the Greater Thames Estuary Historic Environment Research Framework.
- 5.3.6 Aim xiv. The evaluation confirmed that the cropmarks identified in Land Parcel 28 provided a generally accurate representation of the archaeological features present within this part of the site, although some cropmarks did not correspond to features, and some features were not visible as cropmarks. There was less correspondence in Land Parcel 24, with sub-rectangular cropmarks not identified by excavation and several isolated features revealed that were not present as cropmarks. In other parts of the site, a significant number of features were identified that were not identified by cropmarks, particularly in Land Parcel 29.
- 5.3.7 Aim xv. Little evidence was found for Neolithic or Bronze Age activity apart from a few struck flints, only one of which was in a deposit that could potentially be of contemporary date.
- 5.3.8 Aims xvi and xvii. The evaluation confirmed that the ring ditch revealed by the cropmark survey is genuine, and that it is of later prehistoric, and most probably early Iron Age, date. Its function was not established for certain but seems more likely to represent a domestic enclosure than a burial monument. No other evidence for further roundhouses was found, though curvilinear gullies in Land Parcel 28 may have crossed possible other, and smaller, enclosures. These are however undated. Small ring gullies identified in Land Parcel 24 appear too small to represent roundhouse gullies and only two of the four were dated by pottery (Middle Bronze Age to early Iron Age and Iron Age). Their function is unclear, and despite there being no human remains recovered there remains the potential for these to represent small funerary monuments.
- 5.3.9 Aims xviii and xix. No evidence was found for late Iron Age, or Saxon activity on the site. A single sherd of Roman pottery was recovered from ditch 2507 in Land Parcel 24 but this is insufficient to conclusively date this feature.
- 5.3.10 Aim xx. Relatively few discrete archaeological features were identified within the site, and dating for these was limited. Many of the cropmark discrete features,

including the larger pits identified during the cropmark survey were determined to be of natural in origin.

- 5.3.11 Aims xxi and xxii. A system of rectilinear enclosures and probable trackways highlighted during the cropmark survey were shown to be related to 19th century field boundaries, but to be earlier than the historic map evidence of AD1840. Although dating was very limited, what there was suggested that they pertain to an early post-medieval or (just possibly) late medieval arrangement of farmland. These features included parallel pairs of ditches that probably included trackways, but no long-distance tracks were evident running right across the site.
- 5.3.12 Aim xxiii. No medieval or post-medieval buildings were found in the evaluated areas, and the lack of finds from the features that were investigated suggests that any farmstead buildings were located some at some distance from the site.

Appendix A Trench Tables

Trench 1							
General description					Orientation		N-S
Trench revealed two ditches and one natural feature. Trench consists of ploughsoil and subsoil overlying natural geology of silty clay					Length (m)		30
					Width (m)		2
					Avg. depth (m)		0.53
Context No.	Type	Fill Of	Width (m)	Depth (m)	Description	Finds	Date
100	Layer			0.32	Ploughsoil. Dark greyish brown, silty clay		
101	Layer			0.21	Subsoil. Orangish brown, silty clay		
102	Layer				Natural. Reddish brown, silty clay		
103	Cut		0.78	0.12	Ditch		
104	Fill	103	0.78	0.12	Secondary Fill. Soft, brown clayey silt.		
105	Cut		0.68	0.12	Ditch		
106	Fill	105	0.68	0.12	Secondary Fill. brownish-grey, soft, sandy, clayey silt.		
107	Cut		0.42	0.04	Natural Feature		
108	Fill	107	0.42	0.04	Secondary Fill. Soft, brown clayey silt.		
Trench 2							
General description					Orientation		E-W
Trench revealed one possible ditch or, more likely, a natural feature that appears linear within the confines of the trench. Trench consists of ploughsoil and subsoil overlying natural geology of sandy clay					Length (m)		30
					Width (m)		2
					Avg. depth (m)		0.58
Context No.	Type	Fill Of	Width (m)	Depth (m)	Description	Finds	Date
200	Layer			0.35	Ploughsoil. Dark greyish brown, silty clay		
201	Layer			0.23	Subsoil. Orangish brown, silty clay		
202	Layer				Natural. Reddish brown, sandy clay with yellow sand patches		
203	Cut		0.8	0.24	Natural Feature		
204	Fill	203	0.8	0.24	Primary Fill. Orangey brown sandy clay.		
Trench 3							
General description					Orientation		E-W
Trench devoid of archaeology. Consisted of ploughsoil and subsoil overlying natural geology of gravels					Length (m)		30
					Width (m)		2
					Avg. depth (m)		0.52
Context No.	Type	Fill Of	Width (m)	Depth (m)	Description	Finds	Date
300	Layer			0.31	Ploughsoil. Dark greyish brown, silty clay		
301	Layer			0.21	Subsoil. Orangish brown, silty clay		

302	Layer				Natural. Reddish brown mixed with yellow sand patches, silty clay		
303	Cut		1.02	0.26	Tree Throw hole		
304	Fill	303	1.02	0.26	Secondary Fill. Greyish brown, silty clay		

Trench 4

General description						Orientation	N-S
Trench devoid of archaeology. Consists of ploughsoil and subsoil overlying natural geology of clayey silt with sand and gravel patches						Length (m)	30
						Width (m)	2
						Avg. depth (m)	0.52
Context No.	Type	Fill Of	Width (m)	Depth (m)	Description	Finds	Date
400	Layer			0.32	Ploughsoil. Dark grey brown, clayey silt		
401	Layer			0.2	Subsoil. Orangey brown, clayey silt		
402	Layer				Natural. Red and yellow brown, clayey and sandy silt, gravel and sand patches		

Trench 16

General description						Orientation	E-W
Trench devoid of archaeology. Consists of ploughsoil and subsoil overlying natural geology of sandy gravel.						Length (m)	30
						Width (m)	2
						Avg. depth (m)	0.6
Context No.	Type	Fill Of	Width (m)	Depth (m)	Description	Finds	Date
1600	Layer			0.34	Ploughsoil. Greyish brown, sandy silt.		
1601	Layer			0.14	Subsoil. Reddish brown, slightly sandy and clayey silt.		
1602	Layer				Natural. Reddish brown, silty clay with frequent gravel inclusions.		
1603	Cut		0.92	0.4	Ditch		
1604	Fill	1603	0.92	0.4	Primary Fill. Greyish brown, slightly sandy silt.		

Trench 17

General description						Orientation	N-S
Trench revealed a shallow N-S aligned ditch and a tree throw hole containing a dump of burnt debris. Consisted of topsoil and a shallow subsoil overlying the natural of sandy gravel and clay.						Length (m)	30
						Width (m)	2
						Avg. depth (m)	0.45
Context No.	Type	Fill Of	Width (m)	Depth (m)	Description	Finds	Date
1700	Layer		2	0.3	Ploughsoil. Reddish brown clay silt with stony inclusions		
1701	Layer		2	0.3	Subsoil. Brownish red silty clay with very occasional small stones		
1702	Layer				Natural. Mixed gravel with clay patches more frequently at south of trench		
1703	Cut		0.3	0.1	Ditch		
1704	Fill	1703	0.3	0.1	Primary Fill		

1705	Cut				Tree Throw. Probable tree throw with heat altered clay and dense charcoal patches		
1706	Fill	1705			Primary Fill	FC	
Trench 18						Orientation	N-S
General description Trench devoid of archaeology. Consisted of topsoil and subsoil overlying a gravelly clay natural.						Length (m)	30
						Width (m)	2
						Avg. depth (m)	0.4
Context No.	Type	Fill Of	Width (m)	Depth (m)	Description	Finds	Date
1800	Layer		2	0.3	Topsoil. Greyish brown silty clay, friable, frequent flints and river pebbles		
1801	Layer		2	0.1	Subsoil. Brown silty clay, infrequent flints and river pebbles		
1802	Layer		0.2		Natural. Reddish brown clay with patches of gravel and pebble.		
Trench 19						Orientation	E-W
General description Trench revealed one pit which was fully excavated. Consists of topsoil and subsoil overlying natural geology of clay.						Length (m)	30
						Width (m)	2
						Avg. depth (m)	0.56
Context No.	Type	Fill Of	Width (m)	Depth (m)	Description	Finds	Date
1900	Layer			0.28	Topsoil		
1901	Layer			0.22	Subsoil		
1902	Layer				Natural		
1903	Cut		0.48	0.1	Pit		
1904	Fill	1903	0.48	0.1	Secondary Fill. Brownish grey sandy clay	Pot FC Flint Animal bone	LBA
Trench 20						Orientation	NNW-SSE
General description Trench revealed on ditch terminus. Consists of topsoil and subsoil overlying natural geology of clay and gravel.						Length (m)	30
						Width (m)	2
						Avg. depth (m)	0.52
Context No.	Type	Fill Of	Width (m)	Depth (m)	Description	Finds	Date
2000	Layer			0.3	Topsoil		
2001	Layer			0.22	Subsoil		
2002	Layer				Natural		
2003	Cut		0.84	0.2	Ditch		
2004	Fill	2003	0.84	0.2	Primary Fill. Mottled greyish brown clayey silt		
Trench 21						Orientation	N-S
General description						Length (m)	20

Trench revealed a small ring ditch or remnant midden deposit. Consisted of ploughsoil and subsoil above mid orange brown clay gravel.						Width (m)	10.3
						Avg. depth (m)	0.54
Context No.	Type	Fill Of	Width (m)	Depth (m)	Description	Finds	Date
2100	Layer		10.3	0.42	Ploughsoil		
2101	Layer		10.3	0.53	Subsoil. Orange brown subsoil		
2102	Layer				Natural. Orange brown gravelly clay natural.		
2103	Cut		0.84	0.18	Ring Ditch. Cut of ring ditch with concave sides bread to a concave base.		
2104	Fill	2103	0.84	0.18	Primary Fill. Grey brown silty clay fill of ring ditch, likely natural silting.	Pot FC	MBA-EIA
Trench 22						Orientation	E-W
General description Trench devoid of archaeology. Consists of ploughsoil and subsoil overlying clay and gravel natural.						Length (m)	30
						Width (m)	2
						Avg. depth (m)	0.45
Context No.	Type	Fill Of	Width (m)	Depth (m)	Description	Finds	Date
2200	Layer			0.3	Ploughsoil. Grey brown sandy silt.		
2201	Layer			0.15	Subsoil. Reddish brown grey, sandy clay.		
2202	Layer				Natural. Reddish brown clay and sandy gravel.		
Trench 23						Orientation	NE-SW
General description Trench revealed one pit. Trench consists of ploughsoil and subsoil overlying natural geology of silty clay.						Length (m)	30
						Width (m)	2
						Avg. depth (m)	0.5
Context No.	Type	Fill Of	Width (m)	Depth (m)	Description	Finds	Date
2300	Layer			0.3	Ploughsoil. Greyish brown, sandy silt.		
2301	Layer			0.22	Subsoil. Reddish brown, Slightly sandy silt.		
2302	Layer				Natural. Reddish brown, silty clay with frequent gravel inclusions.		
2303	Cut		1.78	0.5	Pit		
2304	Fill	2303	0.68	0.06	Primary Fill. Greyish brown, sandy silt. Compact.		
2305	Fill	2303	0.98	0.46	Secondary Fill. Reddish brown, slightly sandy clayey silt. Compact.	Pot	IA
Trench 24						Orientation	NE-SW
General description Trench revealed one pit. Trench consists of ploughsoil and subsoil overlying natural geology of silty clay.						Length (m)	30
						Width (m)	2
						Avg. depth (m)	0.5
Context No.	Type	Fill Of	Width (m)	Depth (m)	Description	Finds	Date
2400	Layer		2	0.38	Ploughsoil. Grey brown silty clay		

2401	Layer		2	0.5	Subsoil		
2402	Layer				Natural. Orange brown gravelly clay		
2403	Cut		0.26	0.18	Posthole. Cut of small post hole.		
2404	Fill	2403	0.26	0.18	Deliberate Backfill. Yellow brown silty clay only fill of post hole with charcoal flecks throughout.		
2405	Cut		0.41	0.57	Posthole. Sub oval cut of posthole		
2406	Fill	2405	0.41	0.57	Deliberate Backfill. Orange yellow silty clay packing of posthole with charcoal flecks throughout.		

Trench 25						Orientation	WNW_ESE
General description Trench revealed a ditch, a pit and two small ring ditch features along with spreads of possible remnant midden deposits. Consisted of topsoil and subsoil overlying the natural of clay and sandy gravels.						Length (m)	30
						Width (m)	5
						Avg. depth (m)	0.5
Context No.	Type	Fill Of	Width (m)	Depth (m)	Description	Finds	Date
2500	Layer			0.3	Ploughsoil. Grey brown sandy silt		
2501	Layer			0.15	Subsoil. Brown grey, clay sand		
2502	Layer				Natural. Reddish brown clay and sandy gravel.		
2503	Cut		0.84	0.13	Ring Ditch		
2504	Fill	2503			Secondary Fill. Grey sandy clay silt		
2505	Cut		0.82	0.18	Pit		
2506	Fill			0.18	Deliberate Backfill. Grey silt with some charcoal flecks	Flint	
2507	Cut		0.67	0.37	Ditch		
2508	Fill	2507		0.37	Secondary Fill. Brown grey sandy silt.	Pot	MBA-EIA Rom
2509	Cut		0.62	0.1	Other Cut		
2510	Fill	2509		0.1	Secondary Fill. Grey silty sand		
2511	Cut		0.7	0.08	Other Cut		
2512	Fill	2511		0.08	Secondary Fill. Grey, clay silt		
2513	Unexcavated feature				Other Cut. Grey clay silt with charcoal flecks and pottery. Possibly a remnant midden deposit or trample due to irregular appearance.	Pot Flint	MBA-MIA
2514	Unexcavated feature		0.8		Ring Ditch. Grey clay silt with occasional charcoal flecks.	Pot	IA
2515	Fill	2505		0.05	Grey clay		

Trench 26						Orientation	S-N
General description Trench revealed one pit, not fully seen in trench, towards the North end. Two natural features were also excavated. Consists of topsoil and subsoil overlying natural geology of clay and sandy gravel.						Length (m)	30
						Width (m)	2
						Avg. depth (m)	0.4
Context No.	Type	Fill Of	Width (m)	Depth (m)	Description	Finds	Date
2600	Layer			0.24	Topsoil		
2601	Layer			0.22	Subsoil		
2602	Layer				Natural		

2603	Cut				Natural Feature		
2604	Cut				Natural Feature		
2605	Cut		0.72	0.28	Pit		
2606	Fill	2605	0.68	0.16	Primary Fill. Greyish brown silty clay		
2607	Fill	2605	0.72	0.14	Secondary Fill. Brownish grey silty clay	FC	

Trench 27						Orientation	NW-SE
<p>General description</p> <p>Trench was split into two parts across a field boundary in search of a cropmark enclosure. It revealed a single posthole but no evidence of the cropmark targeted. Remnant layers of subsoil were investigated at either end of the trench too. Consisted of ploughsoil and subsoil overlying gravel and clay natural.</p>						Length (m)	30
						Width (m)	2
						Avg. depth (m)	0.4
Context No.	Type	Fill Of	Width (m)	Depth (m)	Description	Finds	Date
2700	Layer			0.2	Ploughsoil. Brown silty clay, friable, rare small flints		
2701	Layer		2	0.2	Subsoil. Orangey brown silty clay, slightly friable		
2702	Layer		2		Natural. Brownish orange silty clay, plastic spreads of large gravel		
2703	Cut		0.5	0.18	Posthole		
2704	Cut		0.35	0.02	Natural Feature. Circular, Greyish brown silty clay, rare tiny flecks of charcoal and burnt clay		
2705	Cut		1.1	0.1	Natural Feature. Irregular side in plan, linear 1.4m long, Brownish grey clayey silt, rare small flints.		
2706	Fill	2703	0.5	0.18	Deliberate Backfill. Brown, slightly sandy silt. Occasional small stone and flint.	Pot	MBA-MIA
2707	Layer			0.26	Subsoil. Reddish brown slightly clayey, sandy silt.		
2708	Layer			0.32	Ploughsoil. Greyish brown, silt.		
2709	Layer				Natural. Reddish brown, silty clay with frequent gravel inclusions.		
2710	Cut		1.35	0.1	Natural Feature. Rooting in corner. Mid brown, sandy silt.	Flint	
2711	Cut		1.9	0.08	Natural Feature. Greyish brown, slightly sandy and clayey silt.		

Trench 28						Orientation	WNW-ESE
<p>General description</p> <p>Trench revealed a single ditch, but no evidence for the cropmark feature targeted. Consisted of topsoil and subsoil overlying a natural geology of gravelly clay.</p>						Length (m)	40
						Width (m)	2
						Avg. depth (m)	0.48
Context No.	Type	Fill Of	Width (m)	Depth (m)	Description	Finds	Date
2800	Layer			0.32	Ploughsoil. Greyish brown ploughsoil, with frequent subangular and subrounded stones		
2801	Layer			0.16	Subsoil. Orangish brown silty sand, friable with frequent small subangular and subrounded stones		
2803	Cut		1.26	0.36	Ditch		

2804	Fill	2803	1.26	0.36	Primary Fill. Orangish brown, silty clay, firmly-compacted with occasional small subangular stones	Flint	
Trench 29							
General description Trench revealed several natural silt pockets and a ditch terminus. Trench contains ploughsoil and subsoil above mid orange brown silty clay natural.					Orientation	N-S	
					Length (m)	30	
					Width (m)	2	
					Avg. depth (m)	0.42	
Context No.	Type	Fill Of	Width (m)	Depth (m)	Description	Finds	Date
2900	Layer		2	0.31	Ploughsoil. Grey brown silty clay sub soil with sub angular and sub rounded pebbles throughout.		
2901	Layer		2	0.4	Subsoil. Orange brown silty clay sub soils layer with pot sherd. Represents variation in natural subsoil.	Slag	
2902	Layer		2	0.17	Subsoil. Orange brown silty clay subsoil.		
2903	Layer				Natural. Orange brown gravelly clay natural.		
2904	Cut		0.6	0.14	Ditch		
2905	Fill	2904	0.6	0.14	Primary Fill. Yellow orange silty clay fill of ditch.		
Trench 30							
General description Trench devoid of archaeology. Consists of topsoil and subsoil overlying mixed natural geology of clay and sandy gravel.					Orientation	N-S	
					Length (m)	30	
					Width (m)	2	
					Avg. depth (m)	0.49	
Context No.	Type	Fill Of	Width (m)	Depth (m)	Description	Finds	Date
3000	Layer		2	0.29	Topsoil. Brown grey clay silt with occasional small stones		
3001	Layer		2	0.2	Subsoil. Orange brown silty clay with rare stony inclusion		
3002	Layer		2		Natural. Mixed patches gravel and Orange yellow silty sand.		
3003	Cut		1.14	0.24	Natural Feature. Bioturbated patch with brown grey silty sand.		
Trench 31							
General description Trench devoid of archaeology. Consists of topsoil and subsoil overlying the natural geology of clay and gravels.					Orientation	ENE-WSW	
					Length (m)	30	
					Width (m)	2	
					Avg. depth (m)	0.35	
Context No.	Type	Fill Of	Width (m)	Depth (m)	Description	Finds	Date
3100	Layer			0.25	Ploughsoil. Grey brown sandy silt.		
3101	Layer			0.05	Subsoil. Grey brown clay silt.		
3102	Layer				Natural. Mixed reddish brown clay and sandy gravels.		
Trench 32							
					Orientation	ENE-WSW	

General description Trench devoid of archaeology. Consists of topsoil and subsoil overlying the natural geology of clay and gravels.						Length (m)		30
						Width (m)		2
						Avg. depth (m)		0.35
Context No.	Type	Fill Of	Width (m)	Depth (m)	Description	Finds	Date	
3200	Layer		2	0.3	Ploughsoil. Brownish grey, sandy silt, friable			
3201	Layer		2	0.25	Subsoil. Reddish brown, sandy silt, firm			
3202	Layer		2		Natural. Reddish brown, sandy gravel, loose			
Trench 33						Orientation		NW-SE
General description Trench devoid of archaeology. Consists of ploughsoil and subsoil overlying natural geology of clayey gravel.						Length (m)		30
						Width (m)		2
						Avg. depth (m)		0.32
Context No.	Type	Fill Of	Width (m)	Depth (m)	Description	Finds	Date	
3300	Layer		2	0.25	Ploughsoil. Brownish grey sandy silt.			
3301	Layer		2	0.18	Subsoil. Firm, reddish brown, sandy clay			
3302	Layer		2		Natural. Firm, reddish brown clayey gravel.			
3303	Cut		0.49	0.1	Natural Feature. Cut of natural feature. Possible linear			
3304	Cut		1.24	0.21	Natural Feature. Natural feature. Possible linear			
Trench 34						Orientation		E-W
General description Trench devoid of archaeology. Consists of ploughsoil and subsoil overlying natural geology of sandy clay.						Length (m)		30
						Width (m)		2
						Avg. depth (m)		0.39
Context No.	Type	Fill Of	Width (m)	Depth (m)	Description	Finds	Date	
3400	Layer		2	0.34	Ploughsoil. Soft, brownish grey sandy silt.			
3401	Layer		2	0.1	Subsoil. Greyish brown sandy clay.			
3402	Layer		2		Natural. Firm, reddish brown sandy clay			
Trench 35						Orientation		N-S
General description Trench revealed one ditch. Consists of ploughsoil and subsoil overlying natural geology of sandy clay.						Length (m)		30
						Width (m)		2
						Avg. depth (m)		0.5
Context No.	Type	Fill Of	Width (m)	Depth (m)	Description	Finds	Date	
3500	Layer		2	0.27	Ploughsoil. Soft brownish grey, sandy silt			
3501	Layer		2	0.23	Subsoil. Firm greyish brown, sandy clay			
3502	Layer		2		Natural. Firm, reddish brown, sandy clay			

3503	Cut		0.64	0.33	Ditch			
3504	Fill	3503	0.64	0.33	Secondary Fill. Brown grey, sandy silt, soft.			
Trench 36						Orientation	E-W	
General description Trench revealed one ditch. Consists of ploughsoil and subsoil overlying natural geology of sandy clay.						Length (m)	30	
						Width (m)		2
						Avg. depth (m)		0.6
Context No.	Type	Fill Of	Width (m)	Depth (m)	Description	Finds	Date	
3600	Layer		2	0.34	Ploughsoil. Soft, brownish grey, sandy silt			
3601	Layer		2	0.37	Subsoil. Firm, brownish grey, sandy clay			
3602	Layer		2		Natural. Firm, reddish brown, sandy clay			
3603	Cut		1.24	0.3	Ditch			
3604	Fill	3603	1.24	0.3	Secondary Fill. Greyish brown, sandy silt, soft			
Trench 37						Orientation	NW-SE	
General description Trench devoid of archaeology. Consists of ploughsoil and subsoil overlying natural geology of sandy clay and gravels.						Length (m)	30	
						Width (m)		2
						Avg. depth (m)		0.6
Context No.	Type	Fill Of	Width (m)	Depth (m)	Description	Finds	Date	
3700	Layer		2	0.35	Ploughsoil. Soft brownish grey, sandy silt.			
3701	Layer		2	0.36	Subsoil. Firm sandy clay, greyish brown			
3702	Layer		2		Natural. Firm, reddish brown, sandy clay			
Trench 38						Orientation	N-S	
General description Trench devoid of archaeology. Consists of ploughsoil and subsoil overlying natural geology of sandy clay.						Length (m)	30	
						Width (m)		2
						Avg. depth (m)		0.6
Context No.	Type	Fill Of	Width (m)	Depth (m)	Description	Finds	Date	
3800	Layer		2	0.29	Ploughsoil. Soft brownish grey, sandy silt			
3801	Layer		2	0.38	Subsoil. Firm, greyish brown, sandy clay			
3802	Layer				Natural. Firm, reddish brown, sandy clay			
Trench 39						Orientation	E-W	
General description Trench devoid of archaeology. Consists of ploughsoil and subsoil overlying natural geology of clayey gravel.						Length (m)	30	
						Width (m)		2
						Avg. depth (m)		0.45
Context No.	Type	Fill Of	Width (m)	Depth (m)	Description	Finds	Date	

3900	Layer		2	0.32	Ploughsoil. Soft brownish grey sandy silt.			
3901	Layer		2	0.25	Subsoil. Firm, greyish brown, sandy clay			
3902	Layer		2		Natural. Firm reddish brown clayey gravel.			
Trench 40						Orientation	N-S	
General description Trench devoid of archaeology. Consists of ploughsoil and subsoil overlying natural geology of sandy clay.						Length (m)	30	
						Width (m)		2
						Avg. depth (m)		0.44
Context No.	Type	Fill Of	Width (m)	Depth (m)	Description	Finds	Date	
4000	Layer		2	0.26	Ploughsoil. Brownish grey, sandy silt, friable			
4001	Layer		2	0.23	Subsoil. Reddish brown, sandy silt, soft			
4002	Layer		2		Natural. Reddish brown, sandy clay with patches of sandy gravel, firm			
Trench 41						Orientation	E-W	
General description Trench devoid of archaeology. Consists of ploughsoil and subsoil overlying natural geology of sandy clay.						Length (m)	30	
						Width (m)		2
						Avg. depth (m)		0.56
Context No.	Type	Fill Of	Width (m)	Depth (m)	Description	Finds	Date	
4100	Layer		2	0.3	Ploughsoil. Brownish grey, sandy silt, friable			
4101	Layer		2	0.28	Subsoil. Reddish brown, sandy silt, soft			
4102	Layer		2		Natural. Brownish red, sandy clay, firm			
Trench 42						Orientation	N-S	
General description Trench devoid of archaeology. Consists of ploughsoil and subsoil overlying natural geology of sandy gravel.						Length (m)	30	
						Width (m)		2
						Avg. depth (m)		0.5
Context No.	Type	Fill Of	Width (m)	Depth (m)	Description	Finds	Date	
4200	Layer		2	0.3	Ploughsoil. Brownish grey, sandy silt, friable			
4201	Layer		2	0.26	Subsoil. Reddish brown, sandy silt, soft			
4203	Layer		2		Natural. Reddish brown, sandy gravel, loose			
Trench 43						Orientation	N-S	
General description Trench devoid of archaeology. Consists of ploughsoil and subsoil overlying natural geology of sandy gravel.						Length (m)	30	
						Width (m)		2
						Avg. depth (m)		0.56
Context No.	Type	Fill Of	Width (m)	Depth (m)	Description	Finds	Date	

4300	Layer		2	0.34	Ploughsoil. Brownish grey, sandy silt, friable		
4301	Layer		2	0.26	Subsoil. Reddish brown, sandy silt, soft		
4302	Layer		2		Natural. Reddish brown, sandy gravel, loose		
Trench 44						Orientation	E-W
General description Trench devoid of archaeology. Consists of ploughsoil and subsoil overlying natural geology of sandy gravel mixed with sandy clay.						Length (m)	30
						Width (m)	2
						Avg. depth (m)	0.5
Context No.	Type	Fill Of	Width (m)	Depth (m)	Description	Finds	Date
4400	Layer		2	0.3	Ploughsoil. Brownish grey, sandy silt, friable		
4401	Layer		2	0.28	Subsoil. Greyish brown, sandy silt, soft		
4402	Layer		2		Natural. Reddish brown, sandy gravel mixed with sandy clay, loose		
Trench 45						Orientation	N-S
General description Trench devoid of archaeology. Consists of ploughsoil and subsoil overlying natural geology of sandy gravel.						Length (m)	30
						Width (m)	2
						Avg. depth (m)	0.46
Context No.	Type	Fill Of	Width (m)	Depth (m)	Description	Finds	Date
4500	Layer		2	0.25	Ploughsoil. Brownish grey, sandy silt, friable		
4501	Layer		2	0.24	Subsoil. Greyish brown, sandy silt, soft		
4502	Layer		2		Natural. Reddish brown, sandy gravel, loose		
Trench 46						Orientation	SW-NE
General description Trench devoid of archaeology. Consists of ploughsoil and subsoil overlying natural geology of sandy gravel mixed with sandy clay.						Length (m)	30
						Width (m)	2
						Avg. depth (m)	0.68
Context No.	Type	Fill Of	Width (m)	Depth (m)	Description	Finds	Date
4600	Layer		2	0.26	Ploughsoil. Brownish grey, sandy silt, friable		
4601	Layer		2	0.46	Subsoil. Greyish brown, sandy silt, soft		
4602	Layer		2		Natural. Reddish brown, sandy gravel mixed with sandy clay, loose		
4603	Cut		0.87	0.13	Natural Feature. Natural feature. Irregular base.		
Trench 47						Orientation	E-W
General description Trench devoid of archaeology. Consists of ploughsoil and subsoil overlying natural geology of sandy clay and gravelly.						Length (m)	30
						Width (m)	2
						Avg. depth (m)	0.65

Context No.	Type	Fill Of	Width (m)	Depth (m)	Description	Finds	Date
4700	Layer		2	0.43	Ploughsoil. Soft brownish grey sandy silt.		
4701	Layer		2	0.15	Subsoil. Reddish brown, firm sandy clay		
4702	Layer		2		Natural. Firm reddish brown sandy clay with pockets of gravel.		
Trench 48						Orientation	N-S
General description Trench devoid of archaeology. Consists of ploughsoil and subsoil overlying natural geology of sandy clay with frequent gravel.						Length (m)	30
						Width (m)	2
						Avg. depth (m)	0.38
Context No.	Type	Fill Of	Width (m)	Depth (m)	Description	Finds	Date
4800	Layer		2	0.3	Ploughsoil. Brownish grey, sandy silt, friable.		
4801	Layer		2	0.08	Subsoil. Reddish brown, sandy silt, soft		
4802	Layer		2		Natural. Reddish brown, sandy clay with frequent gravel		
Trench 49						Orientation	E-W
General description Trench devoid of archaeology. Consists of ploughsoil and subsoil overlying natural geology of sandy clay.						Length (m)	30
						Width (m)	2
						Avg. depth (m)	0.34
Context No.	Type	Fill Of	Width (m)	Depth (m)	Description	Finds	Date
4900	Layer		2	0.32	Ploughsoil. Brownish grey, sandy silt, soft		
4901	Layer		2	0.08	Subsoil. Reddish brown, sandy silt, soft		
4902	Layer		2		Natural. Reddish brown, sandy clay, firm		
Trench 50						Orientation	E-W
General description Trench devoid of archaeology. Consists of ploughsoil and subsoil overlying natural geology of sandy gravel.						Length (m)	30
						Width (m)	2
						Avg. depth (m)	0.65
Context No.	Type	Fill Of	Width (m)	Depth (m)	Description	Finds	Date
5000	Layer		2	0.28	Ploughsoil. Brownish grey, sandy silt, friable		
5001	Layer		2	0.4	Subsoil. Reddish brown, sandy silt, soft		
5002	Layer		2		Natural. Reddish brown, sandy gravel, loose		
Trench 51						Orientation	E-W
General description Trench revealed one ditch. Consists of ploughsoil and subsoil overlying natural geology of sandy gravel.						Length (m)	30
						Width (m)	2
						Avg. depth (m)	0.5

Context No.	Type	Fill Of	Width (m)	Depth (m)	Description	Finds	Date
5100	Layer		2	0.3	Ploughsoil. Brownish grey, sandy silt, friable		
5101	Layer		2	0.2	Subsoil. Reddish brown, sandy silt, soft		
5102	Layer		2		Natural. Reddish brown, sandy gravel, loose		
5103	Cut		0.8	0.28	Ditch. Terminus		
5104	Fill	5103	0.8	0.28	Secondary Fill. Greyish brown, sandy silt, friable and soft		
5105	Cut		0.46	0.1	Natural Feature. Brown yellowish/greyish, sandy silt, firm. Possible tree-throw or roots.		

Trench 52					Orientation	E-W
General description Trench revealed three ditches and a pit. Consists of ploughsoil and subsoil overlying natural geology of sandy gravel.					Length (m)	30
					Width (m)	2
					Avg. depth (m)	0.5

Context No.	Type	Fill Of	Width (m)	Depth (m)	Description	Finds	Date
5200	Layer		2	0.2	Ploughsoil. Brownish grey, sandy silt, friable		
5201	Layer		2	0.3	Subsoil. Reddish brown sandy silt soft		
5202	Layer		2		Natural. Reddish brown, sandy gravel, loose		
5203	Cut		1.3	0.3	Pit		
5204	Fill	5203	1.3	0.3	Other Fill. Yellowish brown, sandy silt, soft.		
5205	Cut		1.04	0.2	Ditch		
5206	Fill	5205	1.04	0.2	Secondary Fill. Greyish brown, sandy silt, soft.		
5207	Cut		0.74	0.15	Ditch		
5208	Fill	5207	0.74	0.15	Secondary Fill. Greyish brown, silty sand, soft.		
5209	Cut		0.9	0.12	Ditch		
5210	Fill	5209	0.9	0.12	Secondary Fill. Greyish brown, silty sand, soft.		

Trench 53					Orientation	NE-SW
General description Trench devoid of archaeology. Consists of ploughsoil and subsoil overlying natural geology of sandy gravel.					Length (m)	30
					Width (m)	2
					Avg. depth (m)	0.51

Context No.	Type	Fill Of	Width (m)	Depth (m)	Description	Finds	Date
Context No.	Layer		2	0.25	Ploughsoil. Greyish brown, sandy silt, soft		
5300	Layer		2	0.26	Subsoil. Reddish brown, sandy silt, soft		
5301	Layer		2		Natural. Light reddish brown, sandy gravel, loose		
5302	Cut		0.7	0.11	Natural Feature. Brown orangish, sandy silt, soft.		

5303							
Trench 54						Orientation	E-W
General description Trench devoid of archaeology. Consists of ploughsoil and subsoil overlying natural geology of sandy gravel.						Length (m)	30
						Width (m)	2
						Avg. depth (m)	0.55
Context No.	Type	Fill Of	Width (m)	Depth (m)	Description	Finds	Date
5400	Layer			0.36	Ploughsoil. Brown greyish, sandy silt, soft		
5401	Layer			0.19	Subsoil. brown orangish, sandy silt, soft		
5402	Layer				Natural. Red brownish, sandy clay with gravelly patches.		
5403	Cut		0.68	0.09	Natural Feature. Brown yellowish, sandy silt, firm. Possible tree throw.		
Trench 55						Orientation	NW-SE
General description Trench devoid of archaeology. Consists of ploughsoil and subsoil overlying natural geology of sandy gravel.						Length (m)	30
						Width (m)	2
						Avg. depth (m)	0.55
Context No.	Type	Fill Of	Width (m)	Depth (m)	Description	Finds	Date
5500	Layer		2	0.34	Ploughsoil. Brownish grey, sandy silt, friable		
5501	Layer		2	0.2	Subsoil. Reddish brown, sandy silt, soft		
5502	Layer		2		Natural. Reddish brown, sandy gravel		
Trench 56						Orientation	NW-SE
General description Trench devoid of archaeology. Consists of ploughsoil and subsoil overlying natural geology of sandy gravel.						Length (m)	30
						Width (m)	2
						Avg. depth (m)	0.4
Context No.	Type	Fill Of	Width (m)	Depth (m)	Description	Finds	Date
5600	Layer		2	0.26	Ploughsoil. Brownish grey, sandy silt, friable		
5601	Layer		2	0.2	Subsoil. Reddish brown, sandy silt, soft		
5602	Layer		2		Natural. Reddish brown, sandy gravel, soft		
Trench 57						Orientation	E-W
General description Trench revealed four ditches. Consists of ploughsoil and subsoil overlying natural geology of sandy gravel.						Length (m)	30
						Width (m)	2
						Avg. depth (m)	0.46
Context No.	Type	Fill Of	Width (m)	Depth (m)	Description	Finds	Date
5700	Layer		2	0.34	Ploughsoil. Brownish grey, sandy silt, friable		

5701	Layer		2	0.12	Subsoil. Reddish brown, sandy silt, soft		
5702	Layer		2		Natural. Reddish brown, sandy gravel, soft		
5703	Cut		0.7	0.14	Ditch		
5704	Fill	5703	0.7	0.14	Secondary Fill. Greyish brown, sandy silt, soft		
5705	Cut		0.46	0.22	Ditch		
5706	Fill	5705	0.46	0.22	Secondary Fill. Greyish brown, sandy silt, soft		
5707	Cut		0.9	0.14	Ditch		
5708	Fill	5707	0.9	0.14	Secondary Fill. Greyish brown, sandy silt, soft		
5709	Unexcavated feature		0.6		Ditch. Linear N-S, Reddish brown, sandy silt, soft		

Trench 58						Orientation	N-S
General description Trench devoid of archaeology. Consists of ploughsoil and subsoil overlying natural geology of sandy gravel.						Length (m)	13
						Width (m)	7
						Avg. depth (m)	0.5
Context No.	Type	Fill Of	Width (m)	Depth (m)	Description	Finds	Date
5800	Layer		7	0.36	Ploughsoil. Brownish grey, sandy silt, friable		
5801	Layer		7	0.24	Subsoil. Reddish brown, sandy silt, soft		
5802	Layer		5		Natural. Reddish brown, sandy gravel, loose		

Trench 59						Orientation	N-S
General description Trench revealed two ditches, two pits and another possible pit or ditch terminus. Consists of ploughsoil and subsoil overlying natural geology of sandy gravel.						Length (m)	10
						Width (m)	6
						Avg. depth (m)	0.4
Context No.	Type	Fill Of	Width (m)	Depth (m)	Description	Finds	Date
5900	Layer		6	0.26	Ploughsoil. Brownish grey, sandy silt, friable		
5901	Layer		6	0.18	Subsoil. Reddish brown, silty, gravel, loose		
5902	Layer		6		Natural. Reddish brown, sandy gravel, loose		
5903	Cut		0.75	0.18	Ditch. Linear ditch. NW-SE		
5904	Fill	5903	0.75	0.18	Secondary Fill. Greyish brown silty sand, friable, soft. Soft		
5905	Cut		0.45	0.3	Ditch. Linear ditch NE-SW		
5906	Fill	5905	0.45	0.3	Secondary Fill. Greyish brown sandy silt, friable, soft.		
5907	Cut		1.60	0.45	Pit. Large ovoid pit 1.75m by 2m.		
5908	Fill	5907	1.6	0.68	Greyish brown silty sand, friable. Env Sample 1.		
5909	Unexcavated feature		2		Pit. Greyish brown silty sand friable, possible ovoid pit.		
5910	Unexcavated feature		0.8		Pit. Greyish brown sandy silt, friable, possible terminus, or ovoid pit		

Trench 60						Orientation	NE-SW
General description Trench revealed two ditches. Consists of ploughsoil and subsoil overlying natural geology of sandy gravel.						Length (m)	30
						Width (m)	2
						Avg. depth (m)	0.5
Context No.	Type	Fill Of	Width (m)	Depth (m)	Description	Finds	Date
6000	Layer		2	0.3	Ploughsoil. Brownish grey, sandy silt, friable		
6001	Layer		2	0.2	Subsoil. Reddish brown, sandy silt, soft		
6002	Layer		2		Natural. Reddish brown, sandy gravel, loose		
6003	Cut		0.62	0.35	Ditch. Terminus		
6004	Fill	6003	0.4	0.1	Primary Fill. Grey, silty sand, frequent gravels, soft.		
6005	Cut		0.67	0.23	Ditch. Curvilinear? Ring ditch?		
6006	Fill	6003	0.67	0.23	Secondary Fill. Grey brownish, sandy silt, moderate gravels, soft.		
6007	Cut		0.5	0.1	Natural Feature. Brown greyish, sandy silt, firm.		
6008	Fill	6003	0.62	0.25	Secondary Fill. Grey brownish, sandy silt, moderate gravels, soft.		
Trench 61						Orientation	NE-SW
General description Trench revealed one ditch. Consists of ploughsoil and subsoil overlying natural geology of sandy gravel.						Length (m)	30
						Width (m)	2
						Avg. depth (m)	0.65
Context No.	Type	Fill Of	Width (m)	Depth (m)	Description	Finds	Date
6100	Layer		2	0.54	Ploughsoil. Brownish grey, sandy silt, friable		
6101	Layer		2	0.1	Subsoil. Reddish brown, sandy silt, soft		
6102	Layer		2		Natural. Reddish brown, sandy gravel, loose		
6103	Cut		1.2	0.4	Natural Feature. Very irregular profile with obvious rooting. Greyish brown, sandy silt, soft.		
6104	Cut		0.94	0.26	Ditch		
6105	Fill	6104	0.94	0.26	Secondary Fill. Greyish brown, sandy silt, soft.		
Trench 62						Orientation	NE-SW
General description Trench revealed two ditches, two pits and two postholes. Consists of ploughsoil and subsoil overlying natural geology of sandy gravel.						Length (m)	30
						Width (m)	2
						Avg. depth (m)	0.5
Context No.	Type	Fill Of	Width (m)	Depth (m)	Description	Finds	Date
6200	Layer		2	0.3	Ploughsoil. Brownish grey, sandy silt, friable		
6201	Layer		2	0.2	Subsoil. Reddish brown, gravelly silt, loose		

6202	Layer		2		Natural. Reddish brown, sandy gravel, loose		
6203	Cut		0.58	0.14	Pit		
6204	Fill	6203	0.58	0.14	Secondary Fill. Friable soft silty sand, greyish brown.		
6205	Cut		1.3	0.34	Pit.		
6206	Fill	6205	1.3	0.34	Secondary Fill. Friable soft sandy silt, greyish brown.		
6207	Cut		0.76	0.16	Ditch.		
6208	Fill	6207	0.76	0.16	Secondary Fill. Greyish brown, friable silty sand.		
6209	Cut		0.2	0.13	Posthole. Within possible ring ditch enclosure [6207] [6213]		
6210	Fill	6209	0.2	0.13	Secondary Fill. Greyish brown silty sand, friable, soft		
6211	Cut		0.25	0.08	Posthole. Possible posthole within possible ring ditch enclosure.		
6212	Fill	6211	0.25	0.08	Secondary Fill. Greyish brown silty sand friable very soft, no finds		
6213	Cut		0.68	0.24	Ditch.		
6214	Fill	6213	0.68	0.24	Secondary Fill. Greyish brown silty sand, friable and soft.		
6215	Cut		2	0.05	Natural Feature. Friable silty sand grey brown. Possible tree throw.		

Trench 63					Orientation	E-W
General description Trench revealed two ditches. Consists of ploughsoil and subsoil overlying natural geology of sandy clay West side and gravelly sand East side of the trench.					Length (m)	30
					Width (m)	2
					Avg. depth (m)	0.48

Context No.	Type	Fill Of	Width (m)	Depth (m)	Description	Finds	Date
6300	Layer		2	0.3	Ploughsoil. Brownish grey, sandy silt, friable		
6301	Layer		2	0.18	Subsoil. Reddish brown, sandy silt, soft		
6302	Layer		2		Natural. Reddish brown, clayey sand at West and gravelly sand at East of the trench, soft		
6303	Cut		0.84	0.22	Ditch		
6304	Fill	6303	0.84	0.22	Secondary Fill. Grey brownish, sandy silt, moderate gravels, soft.		
6305	Cut		0.57	0.11	Ditch		
6306	Fill	6305	0.57	0.11	Secondary Fill. Grey brownish, sandy silt, moderate gravels, soft.		
6307	Cut		0.4	0.17	Natural Feature. Brown yellowish/greyish, sandy silt, firm. Possible tree throw.		
6308	Cut		0.46	0.5	Natural Feature. Brownish orange, sandy silt, soft. Possible tree throw.		

Trench 64					Orientation	N-S
General description Trench devoid of archaeology. Consists of ploughsoil and subsoil overlying natural geology of sandy clay.					Length (m)	30
					Width (m)	2
					Avg. depth (m)	0.36

Context No.	Type	Fill Of	Width (m)	Depth (m)	Description	Finds	Date
6400	Layer		30	0.24	Ploughsoil. Brownish grey, sandy silt, friable		
6401	Layer		2	0.1	Subsoil. Reddish brown, sandy silt, soft		
6402	Layer		2		Natural. Reddish brown, sandy clay, firm		
Trench 65						Orientation	N-S
General description Trench devoid of archaeology. Consists of ploughsoil and subsoil overlying natural geology of sandy clay.						Length (m)	30
						Width (m)	2
						Avg. depth (m)	0.36
Context No.	Type	Fill Of	Width (m)	Depth (m)	Description	Finds	Date
6500	Layer		2	0.31	Ploughsoil. Brownish grey, sandy silt,		
6501	Layer		2	0.05	Subsoil. Reddish brown, sandy silt, soft		
6502	Layer		2		Natural. Reddish brown, sandy clay, firm		
Trench 66						Orientation	N-S
General description Trench devoid of archaeology. Consists of ploughsoil and subsoil overlying natural geology of sandy clay.						Length (m)	25
						Width (m)	2
						Avg. depth (m)	0.34
Context No.	Type	Fill Of	Width (m)	Depth (m)	Description	Finds	Date
6600	Layer		2	0.24	Ploughsoil. Brownish grey, sandy silt, friable		
6601	Layer		2	0.1	Subsoil. Reddish brown, sandy silt, soft		
6602	Layer		2		Natural. Reddish brown, sandy clay, firm		
6603	Cut		0.2	0.15	Natural Feature. Likely rooting. Brownish grey, sandy silt, soft, infrequent charcoal		
Trench 67						Orientation	E-W
General description Trench devoid of archaeology. Consists of ploughsoil and subsoil overlying natural geology of sandy clay.						Length (m)	30
						Width (m)	2
						Avg. depth (m)	0.38
Context No.	Type	Fill Of	Width (m)	Depth (m)	Description	Finds	Date
6700	Layer		2	0.28	Ploughsoil. Brownish grey, sandy silt, friable		
6701	Layer		2	0.1	Subsoil. Reddish brown, sandy silt, soft		
6702	Layer		2		Natural. Reddish brown, sandy clay, firm		
Trench 68						Orientation	N-S
General description						Length (m)	30

Trench devoid of archaeology. Consists of ploughsoil and subsoil overlying natural geology of sandy clay.						Width (m)	2
						Avg. depth (m)	0.34
Context No.	Type	Fill Of	Width (m)	Depth (m)	Description	Finds	Date
6800	Layer		2	0.26	Ploughsoil. Brownish grey, sandy silt, friable		
6801	Layer		2	0.08	Subsoil. Reddish brown, sandy silt, soft		
6802	Layer		2		Natural. Reddish brown, sandy clay, soft		
Trench 69						Orientation	n/a
General description Trench not excavated						Length (m)	n/a
						Width (m)	n/a
						Avg. depth (m)	n/a
Trench 70						Orientation	N-S
General description Trench devoid of archaeology. Consists of ploughsoil and subsoil overlying natural geology of sandy clay.						Length (m)	30
						Width (m)	2
						Avg. depth (m)	0.34
Context No.	Type	Fill Of	Width (m)	Depth (m)	Description	Finds	Date
7000	Layer		2	0.3	Ploughsoil. Brownish grey, sandy silt		
7001	Layer		2	0.04	Subsoil. Reddish brown, sandy silt, firm		
7002	Layer				Natural. Reddish brown, sandy clay, firm		
Trench 71						Orientation	E-W
General description Trench revealed one ditch and two postholes. Consists of ploughsoil and subsoil overlying natural geology of sandy clay.						Length (m)	30
						Width (m)	2
						Avg. depth (m)	0.4
Context No.	Type	Fill Of	Width (m)	Depth (m)	Description	Finds	Date
7100	Layer		2	0.26	Ploughsoil. Brownish grey, sandy silt, friable		
7101	Layer		2		Natural. Reddish brown, sandy clay, firm		
7102	Layer		2	0.12	Subsoil. Brown sandy clay		
7103	Cut		0.21	0.32	Posthole		
7104	Fill	7103	0.21	0.32	Primary Fill. Greyish brown, silty sand, moderately compact. Env Sample 4.		
7105	Cut		0.3	0.22	Posthole		
7106	Fill	7105	0.3	0.22	Primary Fill. Greyish brown, silty sand, moderately compact.		
7107	Cut		0.7	0.28	Ditch		
7108	Fill	7107	0.7	0.28	Primary Fill. Greyish brown, sandy silt, soft. Env Sample 5.		
Trench 72						Orientation	NW-SE

General description Trench revealed two ditches. Consists of ploughsoil and subsoil overlying natural geology of sandy clay.						Length (m)	30
						Width (m)	2
						Avg. depth (m)	0.58
Context No.	Type	Fill Of	Width (m)	Depth (m)	Description	Finds	Date
7200	Layer		2	0.36	Ploughsoil. Brownish grey, sandy silt, friable		
7201	Layer		2	0.13	Subsoil. Reddish brown, sandy silt, soft		
7202	Layer		2		Natural. Reddish brown, sandy clay, firm		
7203	Cut		0.71	0.16	Ditch		
7204	Fill	7203	0.71	0.16	Primary Fill. Greyish brown, sandy silt, soft.		
7205	Cut		1	0.4	Ditch		
7206	Fill	7205	1	0.4	Primary Fill. Greyish brown, sandy silt, soft.	Pot	IA
7207	Cut		0.8	0.22	Natural Feature. Brownish grey, silty sand, soft.		

Trench 73						Orientation	E-W
General description Trench revealed two ditches. Consists of ploughsoil and subsoil overlying natural geology of sandy gravel.						Length (m)	30
						Width (m)	2
						Avg. depth (m)	0.48
Context No.	Type	Fill Of	Width (m)	Depth (m)	Description	Finds	Date
7300	Layer		2	0.26	Ploughsoil. Brownish grey, sandy silt, friable		
7301	Layer		2	0.24	Subsoil. Reddish brown, silty gravel, loose		
7302	Layer		2		Natural. Reddish brown, sandy gravel, loose		
7303	Cut		0.64	0.08	Ditch		
7304	Fill	7303	0.64	0.08	Secondary Fill. Brownish grey, sandy silt, soft.		
7305	Cut		0.52	0.11	Ditch		
7306	Fill	7305	0.52	0.11	Secondary Fill. Brownish orange, sandy silt, soft.		
7307	Cut		1.3	0.3	Natural Feature. Brownish orange, clayey silt with gravels, moderately compact. Possible tree throw.		

Trench 74						Orientation	NW-SE
General description Trench revealed one ditch, three pits and three postholes. Consists of ploughsoil and subsoil overlying natural geology of sandy gravel.						Length (m)	30
						Width (m)	2
						Avg. depth (m)	0.5
Context No.	Type	Fill Of	Width (m)	Depth (m)	Description	Finds	Date
7400	Layer		2	0.36	Ploughsoil. Brownish grey, sandy silt, friable		
7401	Layer		2	0.16	Subsoil. Reddish brown, silty gravel, loose		

7402	Layer		2		Natural. Reddish brown, sandy gravel, loose		
7403	Cut		0.6	0.34	Ditch		
7404	Fill	7403	0.6	0.34	Secondary Fill. Brownish grey, sandy silt, soft		
7405	Cut		0.7	0.48	Posthole		
7406	Fill	7405	0.7	0.48	Secondary Fill. Reddish brown, sandy silt, soft		
7407	Cut		0.68	0.36	Posthole		
7408	Fill	7407	0.68	0.36	Secondary Fill. Brownish grey, sandy silt, soft		
7409	Cut		1.36	0.68	Pit		
7410	Fill	7409	1.36	0.68	Secondary Fill. Brownish Grey, sandy silt, soft.		
7411	Cut		1.7	0.6	Pit		
7412	Fill	7411	0.7	0.12	Other Fill. Brown, sandy silt, soft.		
7413	Fill	7411	1.7	0.58	Secondary Fill. Brownish grey, silty sand, soft.		
7414	Cut		0.5	0.15	Natural Feature. Grey brown, sandy silt, soft. Possible tree throw.		
7415	Unexcavated feature		0.3		Posthole. Brown greyish, sandy silt, soft. Possible posthole.		
7416	Unexcavated feature		1		Pit. Brown, sandy silt, soft.		

Trench 75						Orientation	NW-SE
General description Trench devoid of archaeology. Consists of ploughsoil and subsoil overlying natural geology of sandy gravel.						Length (m)	16
						Width (m)	2
						Avg. depth (m)	0.48
Context No.	Type	Fill Of	Width (m)	Depth (m)	Description	Finds	Date
7500	Layer		2	0.2	Ploughsoil. Brownish grey, sandy silt, friable.		
7501	Layer		2	0.16	Subsoil. Reddish brown, sandy silt, soft		
7502	Layer		2		Natural. Reddish brown, sandy gravel, loose		
7503	Layer				Natural. natural variation, reddish brown, sandy clay, compact.		

Trench 76						Orientation	NW-SE
General description Trench devoid of archaeology. Consists of ploughsoil and subsoil overlying natural geology of sandy gravel.						Length (m)	30
						Width (m)	2
						Avg. depth (m)	0.42
Context No.	Type	Fill Of	Width (m)	Depth (m)	Description	Finds	Date
7600	Layer		2	0.25	Ploughsoil. Brownish grey, sandy silt friable		
7601	Layer		2	0.12	Subsoil. Reddish brown, sandy silt, soft		
7602	Layer		2		Natural. Reddish brown, sandy gravel, loose		
7603	Cut		1.34	0.09	Natural Feature. Shallow natural pit.		

Trench 77						Orientation	E-W
General description Trench devoid of archaeology. Consists of ploughsoil and subsoil overlying natural geology of sandy gravel.						Length (m)	30
						Width (m)	2
						Avg. depth (m)	0.4
Context No.	Type	Fill Of	Width (m)	Depth (m)	Description	Finds	Date
7700	Layer		2	0.24	Ploughsoil. Brownish grey, sandy silt, friable		
7701	Layer		2	0.16	Subsoil. Reddish brown, sandy silt, soft		
7702	Layer		2		Natural. Reddish brown, sandy gravel loose		
7703	Cut		1.15	0.3	Natural Feature. Whitish brown, silty sand, firm, likely geological		
Trench 78						Orientation	N-S
General description Trench revealed four ditches, three pits and two postholes. Consists of ploughsoil and subsoil overlying natural geology of sandy gravel.						Length (m)	12
						Width (m)	8
						Avg. depth (m)	0.38
Context No.	Type	Fill Of	Width (m)	Depth (m)	Description	Finds	Date
7800	Layer		8	0.29	Ploughsoil. Brownish grey, sandy silt, friable		
7801	Layer		8	0.09	Subsoil. Reddish brown, sandy silt, soft.		
7802	Layer		8		Natural. Reddish brown, sandy gravel, loose		
7803	Cut		1.15	0.4	Pit		
7804	Fill	7803	1.15	0.4	Primary Fill. Brownish grey, silty sand, soft.		
7805	Cut		0.36	0.08	Ditch		
7806	Fill	7805	0.36	0.08	Primary Fill. Greyish brown, gravelly sand, friable.		
7807	Cut		0.74	0.3	Ditch		
7808	Fill	7807	0.74	0.3	Primary Fill. Greyish brown, silty sand, soft.	Pot	LBA/IA
7809	Cut		1.14	0.43	Ring Ditch		
7810	Fill	7809	1.14	0.43	Primary Fill. Greyish brown, silty sand, soft. Env Sample 2.	Pot, flint, iron nail	MBA-EIA
7811	Cut		0.36	0.15	Posthole		
7812	Fill	7811	0.36	0.15	Other Fill. Dark greyish brown, gravelly sand, friable. Env Sample 3.		
7813	Cut		0.46	0.42	Ring Ditch		
7814	Fill	7813	0.46	0.42	Primary Fill. Greyish brown, silty sand, soft.	Pot	MBA-EIA
7815	Cut		1.38	0.33	Pit		
7816	Fill	7815	1.38	0.33	Primary Fill. Greyish brown, silty sand, soft.	Pot, flint	IA
7817	Unexcavated feature		0.5		Ditch. Possible pit or ditch terminus. Greyish brown, silty sand.		

7818	Unexcavated feature		0.3		Possible posthole on inner edge of ditch 7809. Mid greyish brown, silty sand.		
7819	Unexcavated feature	7m +	2.5m +		Pit. Possible pit. Greyish brown, sandy silt.		

Trench 79						Orientation	E-W
General description Trench revealed three ditches. Consists of ploughsoil and subsoil overlying natural geology of sandy gravel.						Length (m)	30
						Width (m)	2
						Avg. depth (m)	0.44
Context No.	Type	Fill Of	Width (m)	Depth (m)	Description	Finds	Date
7900	Layer		2	0.24	Ploughsoil. Brownish grey, sandy silt, friable		
7901	Layer		2	0.15	Subsoil. Reddish brown, sandy silt, soft		
7902	Layer		2		Natural. Reddish brown sandy gravel, loose		
7903	Void						
7904	Void						
7905	Cut		1.1	0.17	Ditch. NW/SE		
7906	Fill	7905	1.1	0.17	Primary Fill. Soft greyish brown silty sand		
7907	Cut		1.34	0.3	Ditch. NW/SE		
7908	Fill	7907	1.34	0.3	Primary Fill. Soft brownish grey silty sand with dark inclusions	FC	
7909	Cut		1.75	0.24	Ditch. NW/SE		
7910	Fill	7909	1.75	0.24	Primary Fill. Mod compact brownish grey silty sand		

Trench 80						Orientation	N-S
General description Trench revealed three ditches. Consists of ploughsoil and subsoil overlying natural geology of sandy clay.						Length (m)	30
						Width (m)	2
						Avg. depth (m)	0.36
Context No.	Type	Fill Of	Width (m)	Depth (m)	Description	Finds	Date
8000	Layer		2	0.27	Ploughsoil. Brownish grey, sandy silt, friable.		
8001	Layer		2	0.09	Subsoil. Reddish brown, sandy silt, soft.	Iron fork tine	Modern
8002	Layer			0.3	Natural. Reddish brown, sandy clay, firm Over lies second mid brownish yellow sand natural.		
8003	Cut		1.1	0.26	Ditch		
8004	Fill		1.1	0.26	Secondary Fill. Greyish brown sandy silt, friable soft.		
8005	Cut		0.85	0.14	Ditch. Running E-W		
8006	Fill	8005	0.85	0.14	Secondary Fill. Greyish brown, sandy silt, friable.		
8007	Cut		0.45	0.08	Ditch. Running E-W		
8008	Fill	8007	0.45	0.08	Secondary Fill. Greyish brown sandy silt, friable, firm.		

8009	Cut		1.2		Natural Feature. Greyish brown, sandy silt, soft. Possible tree throw.		
8010	Cut		1.5	0.2	Natural Feature. Greyish brown sandy silt, friable. Possible tree throw.		
Trench 81							
General description Trench revealed two ditches and one posthole. Consists of ploughsoil and subsoil overlying natural geology of sandy clay.					Orientation		E-W
					Length (m)		30
					Width (m)		2
		Avg. depth (m)				0.36	
Context No.	Type	Fill Of	Width (m)	Depth (m)	Description	Finds	Date
8100	Layer		2	0.26	Ploughsoil. Brownish grey, sandy silt, friable		
8101	Layer		2		Subsoil. Reddish brown, sandy silt, soft.		
8102	Layer				Natural. Reddish brown, sandy clay.		
8103	Cut		0.18	0.15	Posthole		
8104	Fill	8103	0.1	0.15	Post-pipe. Brownish grey, silty sand, friable.		
8105	Fill	8103	0.5	0.1	Post-pad. Light brownish grey, silty sand, friable.		
8106	Cut		1.24	0.42	Ditch		
8107	Fill	8106	1.24	0.42	Primary Fill. Greyish brown, sandy silt, soft.		
8108	Cut		0.74	0.26	Ditch		
8109	Fill	8108	0.74	0.26	Primary Fill. Greyish brown, sandy silt, soft.		
Trench 82							
General description Trench devoid of archaeology. Consists of ploughsoil and subsoil overlying natural geology of sandy clay.					Orientation		N-S
					Length (m)		30
					Width (m)		2
		Avg. depth (m)				0.24	
Context No.	Type	Fill Of	Width (m)	Depth (m)	Description	Finds	Date
8200	Layer		2	0.22	Ploughsoil. Brownish grey, sandy silt, friable		
8201	Layer		2	0.16	Subsoil. Reddish brown, sandy silt, soft		
8202	Layer		2		Natural. Reddish brown, silty clay, firm		
Trench 83							
General description Trench devoid of archaeology. Consists of ploughsoil and subsoil overlying natural geology of sandy clay.					Orientation		N-S
					Length (m)		30
					Width (m)		2
		Avg. depth (m)				0.34	
Context No.	Type	Fill Of	Width (m)	Depth (m)	Description	Finds	Date
8300	Layer			0.32	Ploughsoil. Brownish grey, sandy silt, friable.		
8301	Layer			0.04	Subsoil. Reddish brown, sandy silt, soft.		

8302	Layer				Natural. Mid reddish brown, sandy clay, firm.		
Trench 84						Orientation	N-S
General description Trench devoid of archaeology. Consists of ploughsoil and subsoil overlying natural geology of sandy clay.						Length (m)	30
						Width (m)	2.2
						Avg. depth (m)	0.36
Context No.	Type	Fill Of	Width (m)	Depth (m)	Description	Finds	Date
8400	Layer		2.2	0.26	Ploughsoil. Soft sandy silt, mid brownish grey		
8401	Layer		2.2	0.1	Subsoil. Reddish brown, sandy silt, soft.		
8402	Layer				Natural. Soft reddish brown sandy clay		
Trench 85						Orientation	N-S
General description Trench devoid of archaeology. Consists of ploughsoil and subsoil overlying natural geology of sandy clay.						Length (m)	30
						Width (m)	2.2
						Avg. depth (m)	0.37
Context No.	Type	Fill Of	Width (m)	Depth (m)	Description	Finds	Date
Context No.	Layer		2.2	0.32	Ploughsoil. Soft brownish grey, silty clay		
8500	Layer		2.2	0.05	Subsoil. Reddish brown, sandy silt, soft.		
8501	Layer				Natural. Firm reddish brown sandy clay		
Trench 86						Orientation	n/a
General description Trench not excavated						Length (m)	n/a
						Width (m)	n/a
						Avg. depth (m)	n/a
Trench 87						Orientation	E-W
General description Trench devoid of archaeology. Consists of ploughsoil and subsoil overlying natural geology of sandy clay.						Length (m)	30
						Width (m)	2.2
						Avg. depth (m)	0.37
Context No.	Type	Fill Of	Width (m)	Depth (m)	Description	Finds	Date
8700	Layer		2.2	0.32	Ploughsoil. Brownish grey, soft sandy silt		
8701	Layer			0.05	Subsoil. Reddish brown, sandy silt, soft.		
8702	Layer				Natural. Sandy clay, soft, reddish brown		
Trench 88						Orientation	NW-SE
General description Trench devoid of archaeology. Consists of ploughsoil overlying natural geology of sandy clay.						Length (m)	30
						Width (m)	2
						Avg. depth (m)	0.3

Context No.	Type	Fill Of	Width (m)	Depth (m)	Description	Finds	Date
8800	Layer			0.32	Ploughsoil. Soft, brownish grey, sandy silt.		
8801	Layer				Natural. Firm, reddish brown, sandy clay.		
8802	Cut				Natural Feature. Firm, brownish grey, sandy clay. Possible tree throw.		
Trench 89						Orientation	n/a
General description Trench not excavated						Length (m)	n/a
						Width (m)	n/a
						Avg. depth (m)	n/a
Trench 90						Orientation	NW-SE
General description Trench devoid of archaeology. Consists of ploughsoil and subsoil overlying natural geology of sandy clay.						Length (m)	0.28
						Width (m)	0.07
						Avg. depth (m)	0.34
Context No.	Type	Fill Of	Width (m)	Depth (m)	Description	Finds	Date
9000	Layer		2.2	0.29	Ploughsoil. Brownish grey, sandy silt, soft		
9001	Layer		2.2	0.08	Subsoil. Soft sandy clay, reddish brown		
9002	Layer		2.2		Natural. Soft, reddish brown sandy clay		
Trench 91						Orientation	N-S
General description Trench devoid of archaeology. Consists of ploughsoil and subsoil overlying natural geology of sandy clay.						Length (m)	30
						Width (m)	2
						Avg. depth (m)	0.35
Context No.	Type	Fill Of	Width (m)	Depth (m)	Description	Finds	Date
9100	Layer		2	0.26	Ploughsoil. Brownish grey, sandy silt, friable		
9101	Layer		2	0.2	Subsoil. Reddish brown, sandy silt, soft		
9102	Layer				Natural. Reddish brown, sandy clay, firm		
Trench 92						Orientation	E-W
General description Trench revealed one posthole. Consists of ploughsoil and subsoil overlying natural geology of sandy clay.						Length (m)	30
						Width (m)	2
						Avg. depth (m)	0.36
Context No.	Type	Fill Of	Width (m)	Depth (m)	Description	Finds	Date
9200	Layer			0.26	Ploughsoil. Brownish grey, sandy silt, friable		
9201	Layer			0.1	Subsoil. Reddish brown, sandy silt, soft.		
9202	Layer				Natural. Reddish brown, sandy clay, firm.		

9203	Cut		0.43	0.22	Posthole		
9204	Fill	9203	0.27	0.22	Post-pad. dark reddish brown, sandy silt, moderately compact.		
9205	Fill	9203	0.28	0.22	Post-pipe. Greyish brown, sandy silt, moderately compact.		
9206	Cut		1.5	0.1	Natural Feature. orangish brown, sandy silt, possible hollow.		

Trench 93						Orientation	N-S
General description Trench revealed three ditches and two pits. Consists of ploughsoil and subsoil overlying natural geology of sandy clay.						Length (m)	30
						Width (m)	2
						Avg. depth (m)	0.45

Context No.	Type	Fill Of	Width (m)	Depth (m)	Description	Finds	Date
9300	Layer			0.27	Ploughsoil. Brownish grey, sandy silt, friable		
9301	Layer			0.18	Subsoil		
9302	Layer				Natural. Reddish brown, sandy clay, firm.		
9303	Unexcavated feature		0.8		Pit. Brownish grey, sandy silt, soft. Possible pit.		
9304	Cut		0.82	0.4	Natural Feature. Natural feature dark reddish brown sandy fill		
9305	Cut		0.8	0.23	Ditch. Running NW- SE		
9306	Fill	9305	0.8	0.23	Secondary Fill. greyish brown, sandy silt, soft. Env Sample 6.	Burnt flint	
9307	Cut		0.4	0.1	Natural Feature. light greyish brown fill gravel, rooting		
9308	Cut		0.74	0.11	Ditch. Running NE-SW		
9309	Fill	9308	0.74	0.11	Secondary Fill. Greyish brown, sandy silt, gravel		
9310	Cut		0.52	0.34	Pit		
9311	Fill	9310	0.52	0.34	Secondary Fill. Greyish brown, sandy silt soft		
9312	Cut		0.38	0.46	Ditch running E-W.		
9313	Fill	9312	0.38	0.46	Secondary Fill. Greyish brown, sandy silt, charcoal flecks		

Trench 94						Orientation	E-W
General description Trench revealed two ditches. Consists of ploughsoil and subsoil overlying natural geology of sandy clay.						Length (m)	30
						Width (m)	2
						Avg. depth (m)	0.55

Context No.	Type	Fill Of	Width (m)	Depth (m)	Description	Finds	Date
9400	Layer		2	0.24	Ploughsoil. Brownish grey, sandy silt, friable.		
9401	Layer		2	0.3	Subsoil. Reddish brown, sandy silt, soft		
9402	Layer		2		Natural. Reddish brown, sandy clay, firm		
9403	Cut		1.23	0.18	Natural Feature. Pit with irregular base. Possible tree throw.		
9404	Cut		1.04	0.16	Ditch. NW-SE		

9405	Fill	9404	1.04	0.16	Primary Fill. Mod compact light brownish grey silty sand		
9406	Cut		1	0.25	Ditch. NW/SE		
9407	Fill	9406	1	0.25	Primary Fill. Mod compact light brownish grey silty sand		

Trench 95						Orientation	N-S
General description Trench revealed four ditches. Consists of ploughsoil and subsoil overlying natural geology of sandy gravel.						Length (m)	30
						Width (m)	2
						Avg. depth (m)	0.4

Context No.	Type	Fill Of	Width (m)	Depth (m)	Description	Finds	Date
9500	Layer		2	0.26	Ploughsoil. Brownish grey, sandy silt, friable		
9501	Layer		2	0.11	Subsoil. Reddish brown, sandy silt, soft		
9502	Layer		2		Natural. Reddish brown, sandy gravel, loose		
9503	Cut		0.8	0.18	Ditch		
9504	Fill	9503	0.8	0.18	Secondary Fill. Brownish grey, sandy silt, soft, frequent gravel		
9505	Unexcavated feature		0.7		Ditch. Brownish grey, sandy silt, frequent gravel. Same as 9607		
9506	Unexcavated feature		1.2		Ditch. Dark brownish grey, sandy silt, frequent gravel. Same as 9605		
9507	Unexcavated feature		1.56		Ditch. Reddish brown, sandy silt, soft. Same as 9603		

Trench 96						Orientation	N-S
General description Trench revealed three ditches. Consists of ploughsoil and subsoil overlying natural geology of sandy gravel.						Length (m)	30
						Width (m)	2
						Avg. depth (m)	0.44

Context No.	Type	Fill Of	Width (m)	Depth (m)	Description	Finds	Date
9600	Layer		2	0.24	Ploughsoil. Brownish grey, sandy silt, friable		
9601	Layer		2	0.14	Subsoil. Reddish brown, sandy silt, soft		
9602	Layer		2		Natural. Light reddish brown, sandy gravel, loose.		
9603	Cut		2.4	0.24	Ditch		
9604	Fill	9603	2.4	0.24	Secondary Fill. Reddish brown, sandy silt, soft		
9605	Cut		1.3	0.36	Ditch		
9606	Fill	9605	1.3	0.36	Secondary Fill. Dark brownish grey, sandy silt, loose, frequent gravel		
9607	Cut		1	0.2	Ditch		
9608	Fill	9607	1	0.2	Secondary Fill. Brownish grey, sandy silt, loose, frequent gravel		
9609	Unexcavated feature		0.75		Ditch/pit. Brownish grey, sandy silt, loose.		

Trench 97						Orientation	NE-SW
------------------	--	--	--	--	--	-------------	-------

General description Trench devoid of archaeology. Consists of ploughsoil and subsoil overlying natural geology of sandy gravel.						Length (m)	30
						Width (m)	2
						Avg. depth (m)	0.4
Context No.	Type	Fill Of	Width (m)	Depth (m)	Description	Finds	Date
9700	Layer		2	0.2	Ploughsoil. Brownish grey, sandy silt, soft.		
9701	Layer		2	0.18	Subsoil. Reddish brown, sandy silt, soft		
9702	Layer		2		Natural. Reddish brown, sandy gravel		
9703	Cut		1.2		Natural Feature. Light whitish brown, silty sand, form, likely geological		

Trench 98						Orientation	E-W
General description Trench devoid of archaeology. Consists of ploughsoil and subsoil overlying natural geology of sandy gravel.						Length (m)	30
						Width (m)	2
						Avg. depth (m)	0.46
Context No.	Type	Fill Of	Width (m)	Depth (m)	Description	Finds	Date
9800	Layer		2	0.18	Ploughsoil. Brownish grey, sandy silt, friable		
9801	Layer		2	0.24	Subsoil. Brown, sandy silt, soft		
9802	Layer		2		Natural. Light reddish brown, sandy gravel, loose		

Trench 99						Orientation	N-S
General description Trench revealed one pit. Consists of ploughsoil and subsoil overlying natural geology of sandy clay which changes to sandy gravel mid way.						Length (m)	25
						Width (m)	2
						Avg. depth (m)	0.44
Context No.	Type	Fill Of	Width (m)	Depth (m)	Description	Finds	Date
9900	Layer		2	0.26	Ploughsoil. Brownish grey, sandy silt, friable		
9901	Layer		2	0.12	Subsoil. Reddish brown, sandy silt, soft		
9902	Layer		2		Natural. Reddish brown, sandy clay, firm		
9903	Cut	2m +	1.3	0.63	Pit		
9904	Fill	9903	0.34	0.62	Primary Fill. Greyish red, clayey silt, compact.		
9905	Fill	9903	0.5	0.54	Secondary Fill. Greyish brown, clayey silt, moderately compact.		
9906	Cut		3	0.1	Natural Feature. Orangish brown, sandy silt, possible hollow.		

Trench 100						Orientation	E-W
General description Trench devoid of archaeology. Consists of ploughsoil and subsoil overlying natural geology of sandy clay.						Length (m)	30
						Width (m)	2
						Avg. depth (m)	0.46
Context No.	Type	Fill Of	Width (m)	Depth (m)	Description	Finds	Date

10000	Layer		2	0.24	Ploughsoil. Brownish grey, sandy silt, friable		
10001	Layer		2	0.22	Subsoil. Reddish brown, sandy silt, soft		
10002	Layer		2		Natural. Reddish brown, sandy clay, firm		
Trench 101						Orientation	N-S
General description Trench devoid of archaeology. Consists of ploughsoil and subsoil overlying natural geology of sandy clay.						Length (m)	25
						Width (m)	2
						Avg. depth (m)	0.56
Context No.	Type	Fill Of	Width (m)	Depth (m)	Description	Finds	Date
10100	Layer		2	0.3	Ploughsoil. Brownish grey, sandy silt, friable		
10101	Layer		2	0.26	Subsoil. Reddish brown, sandy silt, soft		
10102	Layer		2		Natural. Light reddish brown, sandy clay, firm		
Trench 102						Orientation	NW-SE
General description Trench devoid of archaeology. Consists of ploughsoil and subsoil overlying natural geology of sandy clay.						Length (m)	30
						Width (m)	2.2
						Avg. depth (m)	0.37
Context No.	Type	Fill Of	Width (m)	Depth (m)	Description	Finds	Date
10200	Layer		2.2	0.37	Ploughsoil. Soft brownish grey sandy silt.		
10201	Layer			0.11	Subsoil. Reddish brown, sandy silt, soft.		
10202	Layer				Natural. Soft, reddish brown sandy clay.		
Trench 103						Orientation	NW-SE
General description Trench revealed two ditches. Consists of ploughsoil and subsoil overlying natural geology of clayey sand.						Length (m)	30
						Width (m)	2.2
						Avg. depth (m)	0.5
Context No.	Type	Fill Of	Width (m)	Depth (m)	Description	Finds	Date
10300	Layer			0.33	Ploughsoil. Grey brown silty sand, soft and friable with small flint inclusions		
10301	Layer			0.18	Subsoil. Orangey brown, silty sand, friable		
10302	Layer				Natural. Reddish brown mixed with yellow sand and gravelly patches, clayey sand.		
10303	Cut		0.5	0.19	Natural Feature		
10304	Fill	10303	0.5	0.19	Other Fill. Light whitish grey silty sand with stones inclusions, soft.		
10305	Cut		1	0.1	Ditch. Linear ditch cut		

10306	Fill	10305	1	0.1	Secondary Fill. Light greyish brown, silty clay with stones inclusions, moderately compact.		
10307	Cut		1	0.1	Ditch. Ditch cut		
10308	Fill	10307	1	0.1	Primary Fill. Light orange brown, silty clay with stones inclusions, compact.		
Trench 104						Orientation	SW-NE
General description Trench devoid of archaeology. Consists of ploughsoil and subsoil overlying natural geology of clayey sand.						Length (m)	30
						Width (m)	2.1
						Avg. depth (m)	0.45
Context No.	Type	Fill Of	Width (m)	Depth (m)	Description	Finds	Date
10400	Layer			0.33	Ploughsoil. Grey brown silty sand, soft and friable with small flint inclusions		
10401	Layer			0.12	Subsoil. Orangey brown, silty sand, friable		
10402	Layer				Natural. Orangey/reddish brown mixed with gravelly patches, clayey sand.		
Trench 105						Orientation	E-W
General description Trench devoid of archaeology. Consists of ploughsoil and subsoil overlying natural geology of clayey sand.						Length (m)	30
						Width (m)	2.1
						Avg. depth (m)	0.52
Context No.	Type	Fill Of	Width (m)	Depth (m)	Description	Finds	Date
10500	Layer			0.38	Ploughsoil. Grey brown, silty sand, soft and friable with small flint inclusions		
10501	Layer			0.14	Subsoil. Orangey brown, silty sand, friable		
10502	Layer				Natural. Reddish brown mixed with yellow sand and gravelly patches, clayey sand.		
10503	Cut		0.4	0.02	Tree Throw. Tree throw cut		
10504	Fill	10503	0.4	0.02	Primary Fill. Three throw fill		
Trench 106						Orientation	SE-NW
General description Trench revealed one pit. Consists of ploughsoil and subsoil overlying natural geology of clayey sand.						Length (m)	30
						Width (m)	2.1
						Avg. depth (m)	0.5
Context No.	Type	Fill Of	Width (m)	Depth (m)	Description	Finds	Date
10600	Layer			0.35	Ploughsoil. Grey brown, silty sand, soft and friable with small flint inclusions.		
10601	Layer			0.15	Subsoil. Orangey brown, silty sand, friable		
10602	Layer				Natural. Reddish brown mixed with gravelly patches, clayey sand.		
10603	Cut		0.3	0.06	Pit.		

10604	Fill	10603	0.3	0.06	Other Fill. light brownish grey, sandy silt with stones inclusions.		
Trench 107						Orientation	NE-SW
General description Trench devoid of archaeology. Consists of ploughsoil and subsoil overlying natural geology of clayey sand.						Length (m)	30
						Width (m)	2.2
						Avg. depth (m)	0.48
Context No.	Type	Fill Of	Width (m)	Depth (m)	Description	Finds	Date
10700	Layer			0.33	Ploughsoil. Grey brown, silty sand, soft and friable with small flint inclusions.		
10701	Layer			0.15	Subsoil. Orangey brown, silty sand, friable.		
10702	Layer				Natural. Reddish brown mixed with gravelly patches, clayey sand.		
Trench 108						Orientation	N-S
General description Trench devoid of archaeology. Consists of ploughsoil and subsoil overlying natural geology of clayey sand.						Length (m)	30
						Width (m)	2.1
						Avg. depth (m)	0.68
Context No.	Type	Fill Of	Width (m)	Depth (m)	Description	Finds	Date
10800	Layer			0.4	Ploughsoil. Grey brown, silty sand, soft and friable with small flint inclusions.		
10801	Layer			0.2	Subsoil. Orangey brown, silty sand, friable.		
10802	Layer				Natural. Reddish brown mixed with gravelly patches, clayey sand.		
10803	Void						
Trench 109						Orientation	NW-SE
General description Trench devoid of archaeology. Consists of ploughsoil and subsoil overlying natural geology of clayey sand.						Length (m)	30
						Width (m)	2.1
						Avg. depth (m)	0.53
Context No.	Type	Fill Of	Width (m)	Depth (m)	Description	Finds	Date
10900	Layer			0.34	Ploughsoil. Grey brown, silty sand, soft and friable with small flint inclusions.		
10901	Layer			0.18	Subsoil. Orangey brown, silty sand, friable		
10902	Layer				Natural. Reddish brown mixed with gravelly patches, clayey sand.		
10903	Cut		0.5	0.08	Natural Feature. Slightly elongated pit in plan, mid whitish grey fill		
Trench 110						Orientation	NW-SE
General description Trench devoid of archaeology. Consists of ploughsoil and subsoil overlying natural geology of clayey sand.						Length (m)	30
						Width (m)	2.1
						Avg. depth (m)	0.5

Context No.	Type	Fill Of	Width (m)	Depth (m)	Description	Finds	Date
11000	Layer			0.32	Ploughsoil. Grey brown, silty sand, friable with small flint inclusions.		
11001	Layer			0.2	Subsoil. Orangey brown, silty sand, friable.		
11002	Layer				Natural. Reddish brown mixed with gravelly patches, clayey sand.		
Trench 111						Orientation	NE-SW
General description Trench revealed one ditch. Consists of ploughsoil and subsoil overlaying silty natural						Length (m)	30
						Width (m)	2.2
						Avg. depth (m)	0.5
Context No.	Type	Fill Of	Width (m)	Depth (m)	Description	Finds	Date
11100	Layer		2.2	0.3	Ploughsoil. Grey brown silty sand, friable, with fragmented flint and rounded stone inclusions.		
11101	Layer		2.2	0.2	Subsoil. Yellowish brown silty sand, friable with occasional chalk fleck inclusion		
11102	Layer		2.2		Natural. Orangey brown silty sand with occasional gravel inclusions		
11103	Cut		0.64	0.1	Ditch. 1m slot linear		
11104	Fill	11103	0.64	0.1	Secondary Fill. Orange brownish, clayey sand with rare small stones inclusions, moderately compact.		
Trench 112						Orientation	NW-SE
General description Trench devoid of archaeology. Consists of ploughsoil and subsoil overlaying natural of gravel						Length (m)	30
						Width (m)	2.2
						Avg. depth (m)	0.54
Context No.	Type	Fill Of	Width (m)	Depth (m)	Description	Finds	Date
11200	Layer			0.32	Ploughsoil. Grey brown, silty sand, friable with fragmented flint and rounded stone inclusions		
11201	Layer		2.2	0.24	Subsoil. Yellowish brown, silt sand, friable with flecks of chalk inclusion		
11202	Layer		2.2		Natural. Orangey reddish brown, silty sand, friable with occasional gravel inclusions		
11203	Cut		0.57	0.06	Natural Feature. Light greyish brown silty sand, firm		
Trench 113						Orientation	NE-SW
General description Trench revealed one ditch. Consists of ploughsoil and subsoil overlying natural geology of gravel and silt.						Length (m)	30
						Width (m)	2.2
						Avg. depth (m)	0.49
Context No.	Type	Fill Of	Width (m)	Depth (m)	Description	Finds	Date
11300	Layer		2.2	0.3	Ploughsoil. Grey brown, silty sand, friable, with fragmented flint and rounded stone inclusions		

11301	Layer		2.2	0.2	Subsoil. Orangey brown silty sand, friable		
11302	Layer				Natural		
11303	Cut		0.87	0.16	Ditch. 1m slot but not full profile as it's going under the bulk		
11304	Fill	11303	0.87	0.16	Secondary Fill. Brown orangish, clayey sand with occasional small stones inclusions, moderately compact.		

Trench 114						Orientation	NW-SE
General description Trench devoid of archaeology. Consists of ploughsoil and natural overlaying gravelled natural						Length (m)	30
						Width (m)	2.2
						Avg. depth (m)	0.47
Context No.	Type	Fill Of	Width (m)	Depth (m)	Description	Finds	Date
11400	Layer		2.2	0.3	Ploughsoil. Grey brown silty sand, friable with fragmented flint and rounded stone inclusions		
11401	Layer		2.2	0.17	Subsoil. Mid yellow brown silty sand with occasional chalk fleck inclusions		
11402	Layer		2.2		Natural. Mid orange brown silty sand with gravel patches, firm		

Trench 115						Orientation	E-W
General description Trench devoid of archaeology. Consists of ploughsoil and subsoil overlaying gravelled natural						Length (m)	30
						Width (m)	2.2
						Avg. depth (m)	0.4
Context No.	Type	Fill Of	Width (m)	Depth (m)	Description	Finds	Date
11500	Layer		2.2	0.4	Ploughsoil. Grey brown, silty sand, friable, with fragmented flint and rounded stone inclusions		
11501	Layer		2.2	0.1	Subsoil. Greyish yellow, silty sand with chalk fleck inclusions.		
11502	Layer		2.2		Natural. Orangey brown silty sand with large quantities of gravel.		

Trench 116						Orientation	NW-SE
General description Trench devoid of archaeology. Consists of ploughsoil and subsoil overlaying gravelled natural.						Length (m)	30
						Width (m)	2.2
						Avg. depth (m)	0.5
Context No.	Type	Fill Of	Width (m)	Depth (m)	Description	Finds	Date
11600	Layer		2.2	0.4	Ploughsoil. Grey brown, silty sand, friable with fragmented flint and rounded stone inclusions		
11601	Layer		2.2	0.1	Subsoil. Greyish yellow, silty sand, with chalk fleck inclusions		
11602	Layer		2.2		Natural. Orangey brown, silty sand with large quantities of gravel		

Trench 117						Orientation	E-W
-------------------	--	--	--	--	--	-------------	-----

General description Trench devoid of archaeology. Consists of ploughsoil and subsoil overlaying natural of silty gravel						Length (m)	30
						Width (m)	2.2
						Avg. depth (m)	0.47
Context No.	Type	Fill Of	Width (m)	Depth (m)	Description	Finds	Date
11700	Layer		2.2	0.34	Ploughsoil. Grey brown, silty sand, friable with rounded and fragmented stone inclusions		
11701	Layer		2.2	0.1	Subsoil. Yellow brown, silty sand, friable with occasional rounded stone inclusion		
11702	Layer		2.2		Natural. Light orangey brown silty sand, friable with gravel inclusions throughout		
Trench 118						Orientation	NW-SE
General description Trench devoid of archaeology. Consists of ploughsoil and subsoil overlaying gravelled natural						Length (m)	30
						Width (m)	2.2
						Avg. depth (m)	0.43
Context No.	Type	Fill Of	Width (m)	Depth (m)	Description	Finds	Date
11800	Layer		2.2	0.3	Ploughsoil. Grey brown, silty sand, friable with rounded stone inclusions		
11801	Layer		2.2	0.13	Subsoil. Yellowish brown, silty sand with occasional rounded stone inclusion		
11802	Layer		2.2		Natural. Orangey brown with yellowish brown patches. Firm, silty sand with gravel inclusions		
Trench 119						Orientation	E-W
General description Trench devoid of archaeology. Consists of ploughsoil and subsoil overlaying gravelled natural						Length (m)	30
						Width (m)	2.2
						Avg. depth (m)	0.5
Context No.	Type	Fill Of	Width (m)	Depth (m)	Description	Finds	Date
11900	Layer		2.2	0.3	Ploughsoil. Mid grey brown, silty sand, friable with rounded stone inclusions		
11901	Layer		2.2	0.2	Subsoil. Mid yellowish orangish brown silty sand, friable with occasional rounded stone inclusion		
11902	Layer		2.2		Natural. Orangey brown with yellow patches, firm silty sand with gravel inclusions		
Trench 120						Orientation	E-W
General description Trench revealed two postholes and three ditches. Consists of ploughsoil and subsoil overlying natural geology of sandy clay.						Length (m)	30
						Width (m)	2.2
						Avg. depth (m)	0.49
Context No.	Type	Fill Of	Width (m)	Depth (m)	Description	Finds	Date

12000	Layer		2.2	0.34	Ploughsoil. Greyish brown, silty sand, friable with fragmented stone and rounded pebble inclusions		
12001	Layer		2.2	0.18	Subsoil. Yellowish brown silty sand, friable with flecks of chalk inclusions		
12002	Layer		2.2		Natural. Orangey brown, silty sand with occasional gravel inclusions		
12003	Cut		0.34	0.11	Posthole		
12004	Fill	12003	0.34	0.11	Secondary Fill. Dark greyish brown, sandy clay, firm		
12005	Cut		0.56	0.08	Ditch		
12006	Fill	12005	0.56	0.08	Secondary Fill. Light yellowish grey, sandy clay, firm		
12007	Cut		0.3	0.08	Ditch		
12008	Fill	12007	0.3	0.08	Secondary Fill. Light yellowish grey, sandy clay, firm		
12009	Cut		0.5	0.34	Posthole		
12010	Fill	12009	0.5	0.34	Primary Fill. Dark brownish grey, silty clay, soft		
12011	Cut		0.46	0.06	Ditch		
12012	Fill	12011	0.46	0.06	Secondary Fill. Light greyish brown, sandy clay, firm		
12013	Cut		0.21	0.14	Natural Feature. Possibly an animal burrow or rooting		
12014	Fill	12013	0.21	0.14	Secondary Fill. Brownish grey, sandy clay, firm		
12015	Cut		0.21	0.14	Natural Feature. Brownish grey, sandy clay, firm.		
12016	Unexcavated feature		0.28		Pit. Light yellowish brown, sandy clay, firm		

Trench 121						Orientation	N-S
General description						Length (m)	30
Trench revealed one ditch. Consists of ploughsoil and subsoil overlying natural geology of silty sand.						Width (m)	2.2
						Avg. depth (m)	

Context No.	Type	Fill Of	Width (m)	Depth (m)	Description	Finds	Date
12100	Layer		2.2	0.25	Ploughsoil. Grey brown, silty sand, friable with fragmented and rounded stone inclusions		
12101	Layer		2.2	0.24	Subsoil. Yellowish brown with flecks of chalk, silty sand, friable		
12102	Layer		2.2		Natural. Yellowish brown silty sand with occasional gravel inclusion, firm		
12103	Cut		0.56	0.22	Ditch		
12104	Fill	12103	0.56	0.22	Primary Fill. Light greyish brown, silty clay, firm.		

Trench 122						Orientation	NW-SE
General description						Length (m)	30
Trench devoid of archaeology. Consists of ploughsoil and subsoil overlying natural geology of clayey sand.						Width (m)	2.2
						Avg. depth (m)	0.52

Context No.	Type	Fill Of	Width (m)	Depth (m)	Description	Finds	Date
-------------	------	---------	-----------	-----------	-------------	-------	------

12200	Layer			0.45	Ploughsoil. Grey brown, silty sand, soft and friable with small flint inclusions.		
12201	Layer			0.27	Subsoil. Orangey brown, silty sand, friable.		
12202	Layer				Natural. Reddish brown mixed with gravelly patches, clayey sand.		
Trench 123						Orientation	NE-SW
General description Trench revealed one ditch. Consists of ploughsoil and subsoil overlying natural geology of clayey sand.						Length (m)	30
						Width (m)	2.1
						Avg. depth (m)	0.5
Context No.	Type	Fill Of	Width (m)	Depth (m)	Description	Finds	Date
12300	Layer			0.38	Ploughsoil. Grey brown, silty sand, friable with small flint inclusions.	Flint	Late Prh?
12301	Layer			0.12	Subsoil. Orangey brown, clayey sand		
12302	Layer				Natural. Reddish brown mixed with yellow sand and gravelly patches, clayey sand.		
12303	Cut		0.5	0.2	Ditch. Ditch terminus		
12304	Fill		0.5	0.2	Primary Fill. Ditch fill		
Trench 124						Orientation	N-S
General description Trench devoid of archaeology. Consists of ploughsoil and subsoil overlying natural geology of sandy clay.						Length (m)	30
						Width (m)	2.1
						Avg. depth (m)	0.77
Context No.	Type	Fill Of	Width (m)	Depth (m)	Description	Finds	Date
12400	Layer			0.4	Ploughsoil. Grey brown, silty sand, friable with small flint inclusions.		
12401	Layer			0.3	Subsoil. Mid orangey brown, silty sand, friable.		
12402	Layer				Natural. Reddish brown mixed with gravelly patches, clayey sand		
Trench 125						Orientation	NE-SW
General description Trench devoid of archaeology. Consists of ploughsoil and subsoil overlying natural geology of sandy clay.						Length (m)	30
						Width (m)	2.2
						Avg. depth (m)	0.82
Context No.	Type	Fill Of	Width (m)	Depth (m)	Description	Finds	Date
12500	Layer			0.38	Ploughsoil. Grey brown, silty sand, friable with small flint inclusions.		
12501	Layer			0.32	Subsoil. Orangey brown, silty sand, friable.		
12502	Layer				Natural. Reddish brown mixed with orange sand patches, clayey sand.		
Trench 126						Orientation	NW-SE
General description						Length (m)	30

Trench devoid of archaeology. Consists of ploughsoil and subsoil overlying natural geology of silty clay.						Width (m)	2.1
						Avg. depth (m)	0.49
Context No.	Type	Fill Of	Width (m)	Depth (m)	Description	Finds	Date
12600	Layer			0.34	Ploughsoil. Grey brown silty sand, friable with small fragmented flint inclusions		
12601	Layer			0.18	Subsoil. Yellow brown silty sand, friable with occasional rounded stone inclusions		
12601	Layer		2.2		Natural. Red brown, silty clay, firm with gravel patches.		
Trench 127						Orientation	NE-SW
General description Trench devoid of archaeology. Consists of ploughsoil and subsoil overlying natural geology of clayey sand.						Length (m)	30
						Width (m)	2.2
						Avg. depth (m)	0.56
Context No.	Type	Fill Of	Width (m)	Depth (m)	Description	Finds	Date
12700	Layer			0.34	Ploughsoil. Grey brown, silty sand, friable, with fragmented flint and rounded stone inclusions.		
12701	Layer		2.2	0.27	Subsoil. Yellowish brown, silty sand, friable with rounded stone inclusions		
12702	Layer				Natural. Reddish brown clayey sand, firm with gravel patches throughout the trench		
Trench 128						Orientation	NW-SE
General description Trench devoid of archaeology. Consists of ploughsoil and subsoil overlying natural geology of silty clay.						Length (m)	30
						Width (m)	2.2
						Avg. depth (m)	0.51
Context No.	Type	Fill Of	Width (m)	Depth (m)	Description	Finds	Date
12800	Layer		2.2	0.4	Ploughsoil. Grey brown, silty sand, friable, with fragmented flint and rounded stone inclusions		
12801	Layer		2.2	0.2	Subsoil. Yellowish brown silty sand with flecks of chalk, friable		
12802	Layer		2.2		Natural. Orangey brown silty clay with patches of gravel. Firm		
Trench 129						Orientation	SW-NE
General description Trench revealed two ditches. Consists of ploughsoil and subsoil overlying natural geology of sity sand.						Length (m)	30
						Width (m)	2.2
						Avg. depth (m)	0.47
Context No.	Type	Fill Of	Width (m)	Depth (m)	Description	Finds	Date
12900	Layer		2.2	0.45	Ploughsoil. Greyish brown, silty sand, friable with rounded stone inclusions		
12901	Layer		2.2	0.14	Subsoil. Yellow brown, silty sand with flecks of chalk, friable		

12902	Layer		2.2		Natural. Orangey yellowish brown, silty sand, friable							
12903	Cut		0.36	0.22	Ditch							
12904	Fill	12903	0.36	0.22	Secondary Fill. Light whitish brown, silty clay, firm.							
12905	Cut		0.15	0.1	Ditch							
12906	Fill	12905	0.15	0.1	Secondary Fill. Light beige grey, silty clay, firm.							
Trench 130						Orientation	E-W					
General description Trench revealed one ditch. Consists of ploughsoil and subsoil overlying natural geology of sity sand.						Length (m)	30					
						Width (m)						2.2
						Avg. depth (m)						0.45
Context No.	Type	Fill Of	Width (m)	Depth (m)	Description	Finds	Date					
13000	Layer		2.2	0.37	Ploughsoil. Grey brown, silty sand, friable, with fragmented flint and rounded stone inclusions							
13001	Layer		2.2	0.7	Subsoil. Yellow brown, silty sand with flecks of chalk							
13002	Layer		2.2		Natural. Orangey brown silty sand, friable with occasional gravel inclusions							
13003	Cut		2	0.54	Ditch. Modern boundary							
13004	Fill	13003	2	0.56	Secondary Fill. Light greyish brown, sandy silt, soft	CBM, FC	?					
Trench 131						Orientation	E-W					
General description Trench devoid of archaeology. Consists of ploughsoil and subsoil overlying natural geology of silty gravels.						Length (m)	30					
						Width (m)						2.2
						Avg. depth (m)						0.5
Context No.	Type	Fill Of	Width (m)	Depth (m)	Description	Finds	Date					
13100	Layer			0.35	Ploughsoil. Grey brown, silty sand, friable with fragmented flint and rounded stone inclusions							
13101	Layer			0.15	Subsoil. Grey brown, silty sand with flecks of chalk inclusions, friable							
13102	Layer				Natural. Orangey brown silty sand with large quantities of gravel							
Trench 132						Orientation	NE-SW					
General description Trench devoid of archaeology. Consists of ploughsoil and subsoil overlying natural geology of silty sand						Length (m)	30					
						Width (m)						2.2
						Avg. depth (m)						0.5
Context No.	Type	Fill Of	Width (m)	Depth (m)	Description	Finds	Date					
13200	Layer		2.2	0.3	Ploughsoil. Grey brown, silty sand, friable with fragmented flint and rounded stone inclusions							
13201	Layer		2.2	0.2	Subsoil. Grey brown, silty sand with flecks of chalk inclusions, friable							

13202	Layer		2.2		Natural. Mid orangey reddish brown, silty sand, with gravel inclusions		
Trench 133						Orientation	NE-SW
General description Trench revealed one ditch. Consists of ploughsoil and subsoil overlying natural geology of silty gravels.						Length (m)	30
						Width (m)	2.2
						Avg. depth (m)	0.48
Context No.	Type	Fill Of	Width (m)	Depth (m)	Description	Finds	Date
13300	Layer		2.2	0.3	Ploughsoil. Grey brown, silty sand, friable with fragmented flint and rounded stone inclusions		
13301	Layer		2.2	0.18	Subsoil. Yellow brown, silty sand, friable with occasional rounded stone inclusions		
13302	Layer		2.2		Natural. Orangey brown silty sand with patches of gravel throughout		
13303	Cut		0.73	0.1	Ditch. NE-SW running ditch with shallow sides and concave base		
13304	Fill	13303	0.73	0.1	Secondary Fill. Light greyish brown silty sand, friable, with occasional rounded stone inclusions		
13305	Cut		0.9	0.08	Natural Feature. Light greyish brown with manganese inclusions, firm		
Trench 134						Orientation	N-S
General description Trench devoid of archaeology. Consists of ploughsoil and subsoil overlying natural geology of silty gravels.						Length (m)	30
						Width (m)	2.2
						Avg. depth (m)	0.48
Context No.	Type	Fill Of	Width (m)	Depth (m)	Description	Finds	Date
13400	Layer		2.2	0.3	Ploughsoil. Grey brown, silty sand, friable with rounded and fragmented flint inclusions		
13401	Layer		2.2	0.18	Subsoil. Yellowish brown, silty sand, with occasional rounded stone inclusions		
13402	Layer		2.2		Natural. Orangey brown silty sand with gravel inclusions, friable		
Trench 135						Orientation	NE-SW
General description Trench devoid of archaeology. Consists of ploughsoil and subsoil overlying natural geology of sity sand.						Length (m)	30
						Width (m)	2.2
						Avg. depth (m)	0.5
Context No.	Type	Fill Of	Width (m)	Depth (m)	Description	Finds	Date
13500	Layer		2.2	0.3	Ploughsoil. Grey brown, silty sand, friable with rounded stone and fragmented flint inclusions		
13501	Layer		2.2	0.2	Subsoil. Yellow brown silty sand with flecks of chalk inclusions, friable		
13502	Layer		2.2		Natural. Orangey brown silty sand friable with occasional gravel inclusions		

13503	Cut		0.59	0.07	Natural Feature. Tree bole, fill is mid whitish brown silty sand, no inclusions		
Trench 136						Orientation	NW-SE
General description Trench devoid of archaeology. Consists of ploughsoil and subsoil overlying natural geology of silty sandy gravel.						Length (m)	30
						Width (m)	2.2
						Avg. depth (m)	0.5
Context No.	Type	Fill Of	Width (m)	Depth (m)	Description	Finds	Date
13600	Layer		2.2	0.4	Ploughsoil. Brownish grey, silty sand, friable with fragmented flint and rounded stone inclusions		
13601	Layer		2.2	0.14	Subsoil. Yellowish brown, silty sand, friable with chalk fleck inclusions		
13602	Layer		2.2		Natural. Orangish red, silty clay with gravel inclusions, firm		
13603	Cut		0.64	0.22	Natural Feature. Greyish brown, silty sand, soft. Tree throw		
Trench 137						Orientation	W-E
General description Trench revealed three ditches and two plough scars. Consists of ploughsoil and subsoil overlying natural geology of clayey sand.						Length (m)	30
						Width (m)	2.2
						Avg. depth (m)	0.47
Context No.	Type	Fill Of	Width (m)	Depth (m)	Description	Finds	Date
13700	Layer		2.2	0.37	Ploughsoil. Grey brown, silty sand, friable with fragmented flint and rounded stone inclusions		
13701	Layer		2.2	0.1	Subsoil. Yellowish brown, silty sand, friable with chalk fleck inclusions		
13702	Layer		2.2		Natural. Orangey brown with light yellowish patches, firm, silty sand occasional flint and gravel inclusions		
13703	Cut		0.72	0.06	Ditch		
13704	Fill	13703	0.72	0.06	Secondary Fill. Light greyish brown, clayey sand, soft		
13705	Cut		0.86	0.15	Ditch		
13706	Fill	13705	0.86	0.15	Secondary Fill. Light greyish brown, clayey sand, soft.		
13707	Cut		0.46	0.06	Ditch. Possibly just a plough scar.		
13708	Fill	13707	0.46	0.06	Secondary Fill. Brownish grey, silty sand, soft		
Trench 138						Orientation	NE-SW
General description Trench revealed one ditch. Consists of ploughsoil and subsoil overlying natural geology of clayey sand.						Length (m)	30
						Width (m)	2.2
						Avg. depth (m)	0.5
Context No.	Type	Fill Of	Width (m)	Depth (m)	Description	Finds	Date
13800	Layer		2.2	0.32	Ploughsoil. Grey brown, silty sand, friable with fragmented flint and rounded stone inclusions		

13801	Layer		2.1	0.17	Subsoil. Yellowish brown, silty sand, with flecks of chalk, friable		
13802	Layer		2.2		Natural. Orangish reddish brown, silty sand, friable with occasional gravel inclusion		
13803	Cut		0.64	0.4	Natural Feature. Tree throw, mixed light brownish grey, and mid brownish grey, soft		
13804	Cut		1.48	0.46	Ditch		
13805	Fill	13804	1.48	0.46	Secondary Fill. Greyish brown, sandy silt, soft	CBM	Med?

Trench 139						Orientation	NW-SE
General description Consists of ploughsoil and subsoil overlying natural geology of silty clay. Contains a spread of material.						Length (m)	30
						Width (m)	2.2
						Avg. depth (m)	0.56
Context No.	Type	Fill Of	Width (m)	Depth (m)	Description	Finds	Date
13900	Layer		2.2	0.41	Ploughsoil. Grey brown silty sand, friable with fragmented flint and rounded stone inclusions		
13901	Layer		2.2	0.17	Subsoil. Yellowish brown silty sand, with flecked chalk inclusions. Friable.		
13902	Layer		2.2		Natural. Orangey brown silty sand with light yellowish brown patches, firm		
13903	Layer		6	0.08	Other Layer. Light greyish brown, clayey sand, firm	Flint	Neo?

Trench 140						Orientation	NE-SW
General description Trench revealed one ditch. Consists of ploughsoil and subsoil overlying natural geology of silty clay.						Length (m)	30
						Width (m)	2.2
						Avg. depth (m)	0.53
Context No.	Type	Fill Of	Width (m)	Depth (m)	Description	Finds	Date
14000	Layer			0.3	Ploughsoil. Grey brown silty sand, friable with fragmented flint and rounded stone inclusions		
14001	Layer			0.23	Subsoil. Yellowish brown silty sand, friable with occasional rounded stone inclusions		
14002	Layer				Natural. Reddish brown, silty clay, firm, with gravel patches throughout.		
14003	Cut		0.3	0.08	Ditch		
14004	Fill	14003	0.3	0.08	Primary Fill. Light whitish brown, silty clay, firm.		

Trench 141						Orientation	NW-SE
General description Trench devoid of archaeology. Consists of ploughsoil and subsoil overlying natural geology of silty clay.						Length (m)	30
						Width (m)	2.2
						Avg. depth (m)	0.48
Context No.	Type	Fill Of	Width (m)	Depth (m)	Description	Finds	Date

14100	Layer			0.34	Ploughsoil. Grey brown silty sand, friable with fragmented flint and rounded pebble inclusions.		
14101	Layer			0.14	Subsoil. Yellowish brown, silty sand with occasional rounded pebble inclusions		
14102	Layer				Natural. Reddish brown, silty clay with gravel inclusions		

Trench 142						Orientation	W-E
General description Trench revealed one ditch. Consists of ploughsoil and subsoil overlying natural geology of silty clay.						Length (m)	30
						Width (m)	2.2
						Avg. depth (m)	0.5

Context No.	Type	Fill Of	Width (m)	Depth (m)	Description	Finds	Date
14200	Layer			0.32	Ploughsoil. Grey brown, silty sand, friable with occasional fragmented flint and rounded pebble inclusions		
14201	Layer			0.18	Subsoil. Yellowish brown, silty sand, friable with occasional fragmented stone and rounded pebble inclusions		
14202	Layer		2.2		Natural. Orangey brown silty clay, firm, with gravel and flint inclusions		
14203	Cut		0.7	0.18	Ditch. terminus		
14204	Fill	14203	0.7	0.18	Secondary Fill. Orangey brown whitish, silty sand with rare small stones inclusions, moderately compact		
14205	Cut		0.6	0.25	Tree Throw. Irregular pit tree throw, light orange grey, clayey sand moderately compact fill.		

Trench 143						Orientation	SW-NE
General description Trench devoid of archaeology. Consists of ploughsoil and subsoil overlying natural geology of silty sand.						Length (m)	30
						Width (m)	2.2
						Avg. depth (m)	0.51

Context No.	Type	Fill Of	Width (m)	Depth (m)	Description	Finds	Date
14300	Layer			0.32	Ploughsoil. Grey brown, silty sand, friable with rounded and fragmented stone inclusions		
14301	Layer			0.24	Subsoil. Yellowish brown, silty sand, friable, with chalk flecks		
14302	Layer				Natural. Reddish brown with light yellowish brown, silty sand with occasional gravel inclusions		

Trench 144						Orientation	NW-SE
General description Trench devoid of archaeology. Consists of ploughsoil and subsoil overlying natural geology of silty sand.						Length (m)	30
						Width (m)	2.2
						Avg. depth (m)	0.55

Context No.	Type	Fill Of	Width (m)	Depth (m)	Description	Finds	Date
-------------	------	---------	-----------	-----------	-------------	-------	------

14400	Layer			0.39	Ploughsoil. Grey brown, silty sand, friable, with fragmented flint and rounded stone inclusions		
14401	Layer			0.15	Subsoil. Yellowish brown, silty sand, with chalk inclusions		
14402	Layer				Natural. Reddish brown silty sand, with patches of light yellowish brown silty sand throughout, firm		
Trench 145						Orientation	E-W
General description Trench devoid of archaeology. Consists of ploughsoil and subsoil overlying natural geology of silty sand.						Length (m)	30
						Width (m)	2.2
						Avg. depth (m)	0.5
Context No.	Type	Fill Of	Width (m)	Depth (m)	Description	Finds	Date
14500	Layer			0.3	Ploughsoil. Grey brown, silty sand, friable with rounded stone and fragmented flint inclusions.		
14501	Layer			0.2	Subsoil. Yellow brown silty sand with flecks of chalk throughout, friable		
14502	Layer				Natural. Orangish brown, silty sand, friable with occasional fragmented flint inclusions.		
14503	Cut		0.8	0.3	Natural Feature. Tree bowl, dark brownish grey, silty sand, soft.		
Trench 146						Orientation	NW-SE
General description Trench revealed one ditch. Consists of a ploughsoil overlying a Subsoil and a natural of clayey sand.						Length (m)	30
						Width (m)	2.2
						Avg. depth (m)	0.45
Context No.	Type	Fill Of	Width (m)	Depth (m)	Description	Finds	Date
14600	Layer		2.2	0.35	Ploughsoil. Grey brown, silty sand, friable with fragmented flint and rounded stone inclusions		
14601	Layer		2.2	0.1	Subsoil. Yellowish brown, silty sand, friable with rounded pebbles and flecks of chalk throughout		
14602	Layer		2.2		Natural. Orangish brown with light yellowish grey inclusions		
14603	Cut		0.26	0.06	Ditch		
14604	Fill	14603	0.26	0.06	Secondary Fill. Light greyish brown, clayey sand, firm		
Trench 147						Orientation	NE-SW
General description Trench consists of a ploughsoil overlying a subsoil and a natural of clayey sand. Contains two ditches.						Length (m)	30
						Width (m)	2.2
						Avg. depth (m)	0.49
Context No.	Type	Fill Of	Width (m)	Depth (m)	Description	Finds	Date
14700	Layer		2.2	0.4	Ploughsoil. Grey brown silty sand, friable with rounded stone inclusions		

14701	Layer		2.2	0.12	Subsoil. Yellowish brown silty sand, friable with occasional chalk fleck inclusions		
14702	Layer		2.2		Natural. Orange brown, silty sand, friable with gravel inclusions.		
14703	Cut		0.5	0.05	Ditch. NW-SE aligned gully, very shallow with flattish concave base.		
14704	Fill	14703	0.5	0.05	Secondary Fill. Yellowish brown, silt sand, firm.		
14705	Cut		0.66	0.06	Ditch. NW-SE aligned ditch continues into 137 and also seen in 149		
14706	Fill	14705	0.66	0.06	Secondary Fill. Light yellowish brown, silty sand, soft		

Trench 148					Orientation	NW-SE
General description Trench revealed one pit and one posthole. Consists of ploughsoil and subsoil overlying natural geology of silty sand.					Length (m)	30
					Width (m)	2.2
					Avg. depth (m)	0.43

Context No.	Type	Fill Of	Width (m)	Depth (m)	Description	Finds	Date
14800	Layer		2.2	0.32	Ploughsoil. Greyish brown, silty sand, friable with fragmented flint and rounded stone inclusions		
14801	Layer		2.2	0.1	Subsoil. Yellowish brown silty sand, friable with chalk fleck inclusions		
14802	Layer		2.2		Natural. Orangey brown, silty sand, friable with gravel inclusions		
14803	Cut		0.7	0.12	Pit		
14804	Fill	14803	0.7	0.12	Primary Fill. Light orange brown, silty clay, firm.		
14805	Cut		0.22	0.08	Posthole		
14806	Fill	14805	0.22	0.08	Primary Fill. Light orange grey, silty clay, firm.		

Trench 149					Orientation	E-W
General description Trench consists of a ploughsoil overlying a subsoil and a natural of clayey sand. Contains 2 ditches, a posthole, and a natural feature.					Length (m)	30
					Width (m)	2.2
					Avg. depth (m)	0.47

Context No.	Type	Fill Of	Width (m)	Depth (m)	Description	Finds	Date
14900	Layer		2.2	0.4	Ploughsoil. Greyish brown, silty sand, friable with rounded stone and fragmented flint inclusions.		
14901	Layer		2.2	0.1	Subsoil. Orange brown silty sand friable with rounded stone inclusions		
14902	Layer		2.2		Natural. Orangey brown, silty sand, friable with occasional rounded stone inclusion		
14903	Cut		1.06	0.3	Ditch		
14904	Fill	14903	1.06	0.3	Secondary Fill. Light greyish brown, silty sand, soft		
14905	Cut		0.65	0.1	Ditch		

14906	Fill	14905	0.65	0.1	Secondary Fill. Light yellowish brown, silty sand, soft		
14907	Cut		0.5	0.16	Pit		
14908	Fill	14907	0.5	0.16	Secondary Fill. Dark brownish grey, silty sand, firm		
14909	Cut		0.66		Natural Feature. Tree bowl, mixed mid greyish brown and brownish grey, clayey sand, soft		

Trench 150						Orientation	NW-SE
General description Trench revealed one ditch and two natural features. Consists of ploughsoil and subsoil overlying natural geology of silty clay.						Length (m)	30
						Width (m)	2.2
						Avg. depth (m)	0.5

Context No.	Type	Fill Of	Width (m)	Depth (m)	Description	Finds	Date
15000	Layer		2.2	0.3	Ploughsoil. Grey brown, silty sand, friable, with fragmented flint and rounded stone inclusions		
15001	Layer			0.2	Subsoil. Yellowish brown, silty sand, friable with chalk fleck inclusions		
15002	Layer		2.2		Natural. Orangey reddish brown, silty clay with gravel inclusions, firm		
15003	Cut		0.8	0.14	Ditch		
15004	Fill	15003	0.8	0.14	Secondary Fill. Grey brown, friable, very fine sandy clay		

Trench 151						Orientation	E-W
General description Trench revealed one ditch. Consists of ploughsoil and subsoil overlying natural geology of silty sand.						Length (m)	30
						Width (m)	2.2
						Avg. depth (m)	0.55

Context No.	Type	Fill Of	Width (m)	Depth (m)	Description	Finds	Date
15100	Layer		2.2	0.35	Ploughsoil. Grey brown, silty sand, friable with rounded stone and fragmented flint inclusions.		
15101	Layer		2.2	0.17	Subsoil. Yellow brown silt sand with occasional chalk fleck inclusions		
15102	Layer		2.2		Natural. Orangey brown, silty sand with gravel inclusions, firm		
15103	Cut		0.8	0.28	Ditch. Aligned NE-SW, possible enclosure/boundary ditch possibly modern		
15104	Fill	15103	0.8	0.28	Secondary Fill. Mid orangish greyish brown, silty sand, firm.	CBM	?
15105	Cut		0.43	0.09	Natural Feature. Orangey greyish brown fill of suspected tree bole		

Trench 152						Orientation	N-S
General description Trench revealed one ditch. Consists of ploughsoil and subsoil overlying natural geology of silty sand.						Length (m)	30
						Width (m)	2.2
						Avg. depth (m)	0.46

Context No.	Type	Fill Of	Width (m)	Depth (m)	Description	Finds	Date
-------------	------	---------	-----------	-----------	-------------	-------	------

15200	Layer			0.4	Ploughsoil. Greyish brown, silty sand, friable with rounded pebbles and fragmented flint inclusions.		
15201	Layer			0.16	Subsoil. Yellowish brown, silty sand, friable with flecks of chalk throughout		
15202	Layer				Natural. Yellowish orange silty sand, friable with rounded stone and fragmented flint inclusions		
15203	Cut		0.39	0.07	Ditch. 1m slot linear		
15204	Fill	15203	0.39	0.07	Secondary Fill. brown orangish, silty sand with rare small stones inclusions, soft.		

Trench 153						Orientation	E-W
General description Trench revealed a possible pond. Consists of ploughsoil and subsoil overlying natural geology of silty sand.						Length (m)	30
						Width (m)	2.2
						Avg. depth (m)	0.52
Context No.	Type	Fill Of	Width (m)	Depth (m)	Description	Finds	Date
15300	Layer			0.5	Ploughsoil. Grey brown silty sand, friable with fragmented flint and rounded stone inclusions		
15301	Layer			0.12	Subsoil. Yellowish brown, silty sand with flecks of chalk throughout		
15302	Layer				Natural. Orangey brown silty sand with mid yellowish brown patches, firm.		
15303	Cut		3	0.6	Pond. Eastern slot into 12M pond, visible in subsoil		
15304	Fill	15303	3	0.6	Secondary Fill. Greyish brown, fine sandy clay, friable and very firm	Burnt flint	
15305	Cut		4.6	0.6	Pond. Eastern slot into 12m pond		
15306	Fill	15305	4.6	0.6	Secondary Fill. Greyish brown, very firm, friable, degraded cbm inclusions	FC	

Trench 154						Orientation	N-S
General description Trench revealed one ditch. Consists of ploughsoil and subsoil overlying natural geology of silty clay.						Length (m)	30
						Width (m)	2.2
						Avg. depth (m)	0.57
Context No.	Type	Fill Of	Width (m)	Depth (m)	Description	Finds	Date
15400	Layer			0.42	Ploughsoil. Grey brown silty sand, friable with fragmented flint and rounded stone inclusions		
15401	Layer			0.15	Subsoil. Yellowish brown silty sand with fragmented flint and rounded stone inclusions		
15402	Layer				Natural. Yellowish orange, silty clay with gravel patches.		
15403	Cut		0.9	0.14	Ditch. 1m slot linear		
15404	Fill	15403	0.9	0.14	Secondary Fill. Brown orangish, silty sand with rare small stones, soft.		

Trench 155						Orientation	E-W
General description Trench devoid of archaeology. Trench consists of ploughsoil and subsoil overlaying gravel natural						Length (m)	30
						Width (m)	2.2
						Avg. depth (m)	0.47
Context No.	Type	Fill Of	Width (m)	Depth (m)	Description	Finds	Date
15500	Layer		2.2	0.33	Ploughsoil. Grey brown silty sand, friable with fragmented flint and rounded stone inclusions		
15501	Layer		2.2	0.12	Subsoil. Yellow brown, silty sand, friable with flecks of chalk inclusions.		
15502	Layer		2.2		Natural. Yellow brown silty clay with occasional gravel patches, firm		
Trench 156						Orientation	NW-SE
General description Trench revealed one ditch. Consists of plough soil and subsoil overlying natural geology of silty sand.						Length (m)	30
						Width (m)	2.11
						Avg. depth (m)	0.48
Context No.	Type	Fill Of	Width (m)	Depth (m)	Description	Finds	Date
15600	Layer		2.2	0.32	Ploughsoil. Grey brown, silty sand, friable with fragmented flint and rounded pebble inclusions		
15601	Layer		2.2	0.23	Subsoil. Yellow brown, silty sand, friable with chalk fleck inclusions		
15602	Layer		2.2		Natural. Yellowish orangey brown, silty sand with patches of gravel inclusions		
15603	Cut		0.34	0.09	Ditch. 1m slot linear		
15604	Fill	15603	0.34	0.09	Secondary Fill. Brown orangish, silt sand with rare small stones, soft		
Trench 157						Orientation	E-W
General description Trench devoid of archaeology. Consists of subsoil and ploughsoil covering a natural of silty sand						Length (m)	30
						Width (m)	2.2
						Avg. depth (m)	0.49
Context No.	Type	Fill Of	Width (m)	Depth (m)	Description	Finds	Date
15700	Layer		2.2	0.39	Ploughsoil. Grey brown, silty sand, friable with fragmented flint and rounded stone inclusions		
15701	Layer		2.2	0.1	Subsoil. Yellow brown, silty sand with occasional flecks of chalk, friable.		
15702	Layer		2.2		Natural. Yellowish orangey brown, silty sand with rare gravel inclusions		
15703	Void						
Trench 158						Orientation	NW-SE
General description Trench devoid of archaeology. Consists of ploughsoil and subsoil covering silty natural						Length (m)	30
						Width (m)	2.2
						Avg. depth (m)	0.49

Context No.	Type	Fill Of	Width (m)	Depth (m)	Description	Finds	Date
15800	Layer		2.2	0.3	Ploughsoil. Grey brown silty sand, friable with fragmented flint and rounded stone inclusions		
15801	Layer		2.2	0.12	Subsoil. Yellowish brown. Silty sand, friable with flecks of flint inclusions		
15802	Layer		2.2		Natural. Reddish orangey brown silty sand with clay patches, firm		
15803	Void						

Trench 159					Orientation	NW-SE
General description Trench devoid of archaeology. Consists of subsoil and ploughsoil overlaying a natural of silty sand					Length (m)	30
					Width (m)	2.2
					Avg. depth (m)	0.5

Context No.	Type	Fill Of	Width (m)	Depth (m)	Description	Finds	Date
15900	Layer		2.2	0.37	Ploughsoil. Grey brown silty sand, friable with rounded and fragmented stone inclusions		
15901	Layer		2.2	0.13	Subsoil. Yellow brown, silty sand, friable with flecks of chalk inclusions		
15902	Layer		2.2		Natural. Orangey brown silty sand with large quantities of gravel		

Trench 160					Orientation	E-W
General description Trench devoid of archaeology. Consists of subsoil and ploughsoil overlaying natural geology of gravelly sand.					Length (m)	30
					Width (m)	2.2
					Avg. depth (m)	0.39

Context No.	Type	Fill Of	Width (m)	Depth (m)	Description	Finds	Date
16000	Layer		2.2	0.29	Ploughsoil. Grey brown, silty sand, friable with fragmented flint and rounded stone inclusions		
16001	Layer		2.2	0.1	Subsoil. Yellowish brown silty sand, friable with occasional chalk fleck inclusions		
16002	Layer		2.2		Natural. Yellowish orange, silty sand with large gravel patches		

B.1 Prehistoric Pottery

By Alex Davies

Introduction

- B.1.1 The evaluation recovered 108 sherds (1221g) of prehistoric pottery from 12 contexts across seven trenches. The material came from two areas. The northern area consisted of material from Trenches 19-27, and the central area from Trenches 72 and 78. The assemblage as a whole is well-preserved with a mean sherd weight of 11.3g, although this is biased as the assemblage is dominated by sherds from two contexts, contexts 1905 and 7810.
- B.1.2 The assemblage from Trenches 19-27 is dominated by flint fabrics in coarse, medium and fine grades. Sandy fabrics are also present. The only diagnostic material is in context 1905, and this is a fineware carinated jar that is comparable to a late Bronze Age vessel from nearby Mucking South Rings (Brudenell 2016a, fig. 3.31.74). Similar vessels are also present in the earliest and early Iron Age. It is possible that the rest of the material from Trenches 19-27 is late Bronze Age, although the presence of sherds in sandy fabrics in contexts 2305 and 2514 suggests that the assemblage also includes Iron Age material. Sandy, flint-free fabrics were very rare in the late Bronze Age assemblages at Mucking North Ring (Barrett 1988) and South Ring (Brudenell 2016a, fig. 2.38C).
- B.1.3 The material in Trenches 72 and 78 includes only a single feature sherd – a rim decorated with a fingernail impression on the top. This is a long-lived trait that is present throughout the middle Bronze Age to early Iron Age. Dating across these trenches is based only on fabrics. The material could belong to a single period, the early Iron Age, although spot-dates for most of the contexts is quite wide and other periods (the middle-late Bronze Age and the middle Iron Age) might be represented.
- B.1.4 Flint is the dominant fabric, followed by quartz sand, then a vesicular fabric probably originally containing shell. Fabrics can be compared with nearby later prehistoric assemblages at Mucking (Barrett 1988; Brown 2016; Brudenell 2016a; 2016b) and Orsett Cock (Brown 1998). Flint was the dominant local fabric during the middle and late Bronze Age, being steadily replaced with quartz sand through the Iron Age. Flint remained popular well into the middle Iron Age, with sand only becoming dominant around the second century BC (Brudenell 2016b, 380). Vesicular fabrics are a minor component throughout the period. The assemblage is too small for any meaningful statistical comparisons of fabrics to be made, but the presence of two very small and abraded sherds in a quartz sand fabric in context 7816 might suggest that the assemblage in Trench 78 as a whole belongs to the Iron Age rather than the later Bronze Age.

Retention

- B.1.5 All the material has future research potential and should be retained.

Context	Sherds	Weight (g)	Fabric	Spot-date	Comment
1905	33	593	Flint, med and fine	LBA	Poss EIA. Inc fineware carinated jar like Mucking South Rings fig. 3.31.74 (Brudenell 2016a). 3 sherds from sample 9.

2104	9	48	Flint, coarse and fine	MBA-EIA	
2305	1	1	Sand	IA	
2508	1	10	Flint, coarse	MBA-EIA	Also one Roman sherd
2513	4	36	Flint, med	MBA-MIA	
2514	2	5	Sand	IA	
2706	1	1	Flint	MBA-MIA	Very abraded
7206	2	4	Sand	IA	
7808	1	15	Voids (?shell), med	LBA/IA	Quite thin-walled. Junction between base and wall
7810	51	481	Flint, med	MBA-EIA	Inc from sample 2. Fingernail dec on rim top
7814	1	26	Flint, med	MBA-EIA	
7816	2	1	Sand	IA	Very abraded
Total	108	1,221			

Table 1: Prehistoric pottery by context, sherd number, weight and date

B.2 Ceramic building material and fired clay

By Ruth Shaffrey and Alex Davies

- B.2.1 A total of seven fragments of ceramic building material (CBM, 541g) and 28 fragments of fired clay (154g) were retained and submitted for analysis. These are described and discussed separately below.
- B.2.2 The assemblage of CBM is highly fragmented and comprises two pieces of flat tile (15104; 36g), one piece of indeterminate form (13004; 1g) and one fragment of brick (13805; 504g). The tile and indeterminate fragment are not datable, but the brick, which measures 72mm wide by only 46mm thick, is an early type, and is probably late medieval or early post-medieval in date.
- B.2.3 Fired clay was recovered from seven contexts: 1706 (31g), 1904 (6g), 2104 (7g), 2607 (31g), 7908 (22g), 13004 (4g) and 15306 (53g). It is all amorphous and cannot be assigned to a functional category.
- B.2.4 None of the fired clay or CBM needs to be retained.

B.3 Flint

By Michael Donnelly

Introduction

- B.3.1 A very small assemblage of six struck flints and five fragments of burnt unworked flint weighing 96g was recovered from this evaluation (see Table 2). Three struck flints came from the topsoil of Trench 123, and two from Trench 78, but from different contexts. The assemblage was largely undiagnostic but some pieces were typical of Neolithic or early Bronze Age working while flakes from context 12300 were more typical of later industries. Overall, the assemblage indicates only very limited flint-related activity at this location.

Context	Type	Sub-type (g)	Notes	Date
7810	Flake	Inner		
7816	Flake	Distal trimming		
9306	Burnt unworked	Fragments x 4	19g all from sample	
12300	Notch	Inner blade	Probable notch on right side of irregular blade	
12300	Flakes x 2	Side trimming & preparation	Quite squat forms in poor condition	?LPH
13903	Retouched flake	Inner	Regular flake with flaked platform margins and finely executed retouch left, right and partially distal	?Neo
15304	Burnt unworked		77g, hand recovered	

Table 2: Flints by context, type, sub-type and provisional date

- B.3.2 Several of the flints were recovered from samples suggesting that much of the flintwork may have been missed during hand excavation, although the overall low numbers make this unlikely. One sample from context 9306, Trench 93, yielded just burnt unworked fragments while another sample from Trench 78, fill 7810 yielded a flint flake. That trench also contained another struck flint from 7816.
- B.3.3 Trench 123 yielded two squat flakes and a notch on an inner blade. The former pieces are very typical of later prehistoric knapping while the latter piece is more likely to be Neolithic in date. Notches can occur accidentally and can happen during excavation, but here the retouch on the notch looked to be old and it is probably genuine.
- B.3.4 **Trench 139.** Fill 13903 produced a very regular inner flake with fine scaler edge retouch along both its left and right sides as well as along around half of its distal edge from right to centre. The flakes platform margins showed preparation in the form of fine trimming flakes/spalls, and in overall form the flake probably represents Neolithic or early Bronze Age workmanship.
- B.3.5 **Trench 153.** Fill 15304 contained a single large piece of burnt unworked flint weighing 77g.

Discussion

- B.3.6 The lithics recovered from this evaluation indicate only very limited flint-related activity here. There was a slight concentration of flints in the area of Trenches 123 and 139, but with so few flints this may not be meaningful. Two periods of flintwork appear to be represented with some of the flints being of Neolithic – early Bronze Age character, and others more typical of middle Bronze Age or later industries. This further dilutes the limited activity identified here.

Methodology

- B.3.7 The artefacts were catalogued according to OA South's standard system of broad artefact/debitage type (Anderson-Whymark 2013; Bradley 1999), general condition noted, and dating was attempted where possible. The assemblage was catalogued directly onto an Open Office spreadsheet. During the assessment additional information on condition (rolled, abraded, fresh and degree of cortication), and state of the artefact (burnt, broken, or visibly utilised) was also recorded. Retouched pieces were classified according to standard morphological descriptions (e.g. Bamford 1985, 72-77; Healy 1988, 48-9; Bradley 1999). Technological attribute analysis was initially undertaken and included the recording of butt and termination type (Inizan et al. 1999), flake type (Harding 1990), hammer mode (Onhuma and Bergman 1982), and the presence of platform edge abrasion.

B.4 Metal finds

By Anni Byard

Introduction and methodology

- B.4.1 Two iron objects weighing a total of 19.6g were recovered from the site during evaluation. Finds were scanned during the assessment and a century or broad period dates were assigned where possible. Objects were quantified by type, count and weight by context and recorded in Table 3 below.

Description

Context	SF no.	Material	Count	Weight	Object	Date	Description
7810	2	Fe	1	1.4	Nail	Modern	Round sectioned shank, flat round head
8001		Fe	1	18.2	Tool	Modern	Fork tine point

Table 3: Metal finds by context, type, description and date

Discussion

- B.4.2 Both metalwork finds are of modern (post AD 1850) date. The round-shanked nail is corroded but its form and size indicate a modern, probable 20th century date. The fragment of fork tine is likely to be of similar date.

Discard, and retention of material

- B.4.3 The metalwork has been recorded and holds no intrinsic value for comparative analysis, so need not be retained.

B.5 Slag

By Geraldine Crann

Description

Context	Description
2901	A single fragment of iron working tap slag weighing 17g.

Table 4: Slag by context

Discussion

- B.5.1 A single fragment of tap slag was recovered from context 2901. The slag should be retained.

C.1 Environmental Samples

By Richard Palmer

Introduction

- C.1.1 Nine bulk samples were taken from a range of features across the excavated trenches primarily for the retrieval and assessment of charred plant remains (CPR) and the recovery of bones and artefacts. Samples were 40L in volume or 100% of the available deposit.

Method

- C.1.2 The samples were processed in their entirety at Oxford Archaeology using a modified Siraf-type water flotation machine. The flots were collected in a 250µm mesh and residues in a 500µm mesh and dried. The residue fractions were sorted by eye and with the aid of a magnet while the flot material was sorted using a low power (x10) binocular microscope to extract cereal grains and chaff, smaller seeds and other quantifiable remains.

Results

- C.1.3 Bulk (CPR) sample and flot data is presented in Table 5 which provides the relative abundances of the primary flot components.
- C.1.4 **Trench 17.** Sample 7 from fill 1706 of tree throw 1705 produced a flot which contained abundant charcoal. The majority of charcoal appears to be a ring porous type with identified fragments being oak (*Quercus* sp.). Fired clay was extracted from the residue.
- C.1.5 **Trench 19.** Sample 9 from fill 1904 of pit 1903 produced a poor flot. The single identified grain is possibly oat (cf. *Avena sativa*) but the poor condition of the grain adds significant uncertainty to the identification. Pottery was recovered from the residue.
- C.1.6 **Trench 26.** Sample 8 from fill 2607 of pit 2605 produced a large flot that is mainly composed of modern roots with a small quantity of charred material. Identified grain is wheat (*Triticum* sp.) and a damaged glume is also present as are speedwell seeds (*Veronica* sp.). Fired clay was extracted from the residue.
- C.1.7 **Trench 59.** Sample 1 from fill 5908 of pit 5907 produced limited results consisting of charcoal fragments mostly in the 4-2mm size category. A small number of the burrowing snail *Cecilioides acicula* was also recovered but these have not been quantified as their burrowing nature limits the ecological significance of the species. No finds were recovered from the residue.
- C.1.8 **Trench 71.** Sample 4 from fill 7104 of posthole 7103 produced a poor flot of charcoal and clinker-like material. No finds were recovered from the residue.
- C.1.9 Sample 5 from fill 7108 of ditch 7107 produced a limited flot with no >4mm material. Several hazelnut shell fragments (*Corylus avellana*) and a small amount of grain in poor condition are present with the grain likely to be wheat (*Triticum* sp.). Sedge seeds (Cyperaceae) and charred goosefoot seeds (*Chenopodium* sp.) are present in the weed assemblage. No finds were recovered from the residue.
- C.1.10 **Trench 78.** Sample 2 from fill 7810 of ring ditch 7809 produced a poor flot consisting of charcoal and indeterminate charred material. Pottery, flint and iron were recovered from the residue.
- C.1.11 Sample 3 from fill 7812 of posthole 7811 produced a poor flot consisting of charcoal in the 4-2mm size range. No finds were recovered from the residue.

C.1.12 **Trench 93.** Sample 6 from fill 9306 of ditch 9305 produced a limited flot consisting of a moderate quantity of charcoal and a small CPR assemblage. Recovered grain is in poor condition and is likely to be wheat. The weed assemblage primarily consists of a mix of charred and modern goosefoot seeds. Burnt flint was recovered from the residue.

Discussion

C.1.13 Recovery of charred material other than charcoal from these samples was limited and material from the more productive features was in poor condition. This is not necessarily indicative of the potential for the preservation of charred remains across the site as postholes and ditches often include small quantities of redeposited material and other features that are as yet unexcavated may hold greater quantities of charred plant remains. Terrestrial molluscs (snails) were not preserved in the sampled deposits.

Recommendations for retention/disposal

C.1.14 The flots warrant retention until all works on site are complete but further work is not expected to be required at this time.

Sample no.	Context no.	Trench	Feature/Depo sit	Date	Sample Vol. (L)	Flot Vol (ml)	Charcoal >2mm	Grain	Chaff	Weeds	Molluscs	Other	Notes
1	5908	59	5907		40	25	++						10YR 4/6 sandy loam
2	7810	78	7809	MBA-EIA	40	10	++						10YR 4/6 sandy silt loam
3	7812	78	7811		3	5	++						10YR 4/6 sandy loam
4	7104	71	7103		6	5	++						7.5YR 5/4 sandy loam
5	7108	71	7107		10	14	+	++		++		+	10YR 4/6 sandy silt loam
6	9306	93	9305		40	18	+++	++		++			10YR 4/6 sandy loam
7	1706	17	1705		30	100	++++						Mid orange-brown sandy silt.
8	2607	26	2605		18	60	++	+	+	+			Mid orange-brown clayey silt.
9	1904	19	1903		10	15	++	+					Mid orange-brown sandy silt.

Key: +=present (up to 5 items), ++=frequent (5-25), +++=common (25-100), ++++=abundant (100+)

Table 5: Assessment of bulk CPR samples

C.2 Animal bone

By Adrienne Powell

- C.2.1 A single fragment of animal bone was recovered from environmental sample 9, context 1904. This comprised the distal half of a sheep/goat metapodial condyle (<1g) which was calcined but otherwise in good condition.

Recommendations

- C.2.2 No further information can be gained from this fragment and retention in the archive is not merited.

Appendix D References

- Anderson-Whymark, H 2015 The flint, in Allen, T, Barclay, A, Cromarty, A, M, Anderson-Whymark, H, Parker, A, Robinson, M, and Jones, G, *Opening the wood, making the Land; The Archaeology of a Middle Thames Landscape, Mesolithic, Neolithic and Bronze Age, Vol 1*, Oxford: Oxford Archaeological Unit. Thames Valley Landscapes Monograph **38**.
- Bamford, H, 1985 *Briar Hill: excavation 1974-1978*, Northampton: Northampton Development Corporation. Archaeological monograph **3**.
- Barrett, J C, 1988 Pottery, in Bond, D *Excavation at the North Ring, Mucking, Essex*, East Anglian Archaeology **43**, 25-37.
- Bradley, P, 1999 The worked flint. In Barclay, A and Halpin, C. *Excavations at Barrow Hills, Radley, Oxfordshire*, Oxford: Oxford Archaeological Unit. Thames Valley Landscapes Monograph **11**: 211-227.
- BGS 2019 Geology of Britain Viewer, British Geological Survey, [REDACTED]
- Brown, N, 2016 Earlier/Middle Bronze Age Pottery, in Evans, C, Appleby, G and Lucy, S with Appleby, J and Brudenell, M *Lives in the Land. Mucking Excavations by Margret and Tom Jones, 1965-1978: Prehistoric, Context and Summary*, Oxbow Books, 105-10
- Brown, N, 1998 Earlier Iron Age pottery, in Carter, G A *Excavations at the Orsett 'Cock' Enclosure, Essex, 1976*, East Anglian Archaeology **86**, 88-9.
- Brudenell, M. 2016a Late Bronze Age Pottery, in Evans, Appleby, G and Lucy, S with Appleby, J and Brudenell, M *Lives in the Land. Mucking Excavations by Margret and Tom Jones, 1965-1978: Prehistoric, Context and Summary*, Oxbow Books, 158-88.
- Brudenell, M, 2016b Middle Iron Age Pottery, in Evans, C Appleby, G and Lucy, S with Appleby an Brudenell, M *Lives in the Land. Mucking Excavations by Margret and Tom Jones, 1965-1978: Prehistoric, Context and Summary*, Oxbow Books, 365-93.
- ClfA, 2014a *Standard and Guidance for Archaeological Evaluation*, Chartered Institute for Archaeologists, [REDACTED]
- ClfA, 2014b *Standard and Guidance for the Creation, Compilation, Transfer and Deposition of Archaeological Archives*, Chartered Institute for Archaeologists
- Harding, P, 1990 The worked flint, in *The Stonehenge environs project*, (ed J C Richards) London, English Heritage.
- Healy, F, 1988 *The Anglo-Saxon Cemetery at Spong Hil, North Elmham, Part VI: Occupation during the seventh to second Millennia BC*, East Anglian Archaeological reports **38**.

- Hedges, J D and Buckley, D G, 1978 Excavations at a Neolithic causewayed enclosure, Orsett, Essex, 1975. *Proceedings of the Prehistoric Society* **44**, 219–308
- Highways England 2018 *Lower Thames Crossing: A Scheme Wide Specification for Archaeological Trial Trenching*: unpublished document HE540039-CJVGEN- GEN-SPE-HER-00001draft, Revision 1.05
- Historic England 2015 *Management of Research Projects in the Historic Environment: The MoRPHE Project Managers' Guide*. Swindon: Centre for Archaeology Guidelines.
- Inizan, M-L, Reduron-Ballinger, M, Roche, H and Tixier, J, 1999 *Technology and terminology of knapped stone*, Cercle de Recherches et d'Etudes Préhistoriques, CNRS, Nanterre.
- Lavender, N J 1998 *Prehistoric and Roman-British Activity at the William Edwards School, Stifford Clays Road, Grays; excavations 1997*, Essex Archaeology and History **29**, 19-32.
- Medlycott, M ed. 2011 *Research and Archaeology Revisited: A Revised Framework for the East of England*. East Anglian Archaeology Occasional Paper **24**: Association of Local Government Archaeological Officers.
- Onhuma, K and Bergman, C A 1982 Experimental studies in the determination of flake mode, *Bulletin of the Institute of Archaeology, London* **19**, 161-171.
- Oxford Archaeology, 2019a *Lower Thames Crossing Scheme-wide Written Scheme of Investigation for Trial Trenching south of the River Thames*.
- Oxford Archaeology, 2019b *Lower Thames Crossing Scheme-wide Written Scheme of Investigation for Trial Trenching north of the River Thames*.
- Oxford Archaeology 2020 *Lower Thames Crossing: Detailed Written Scheme of Investigation M for Trial Trenching of Land Parcels 24-29*, unpublished document, HE540039-BAL-GEN-GEN-REP-HER-00015, version 1.2
- OCA, 2020a *Lower Thames Crossing: Archaeological Evaluation Report for Trial Trenching of Land Parcel 22, Whitfield South Scheduled Monument Cropmark Complex, South of Stifford Clays Road, Baker Street, Essex*, unpublished document by Oxford Cotswold Archaeology, HE540039-BAL-GEN-GEN-REP-HER-00026
- OCA, 2020b *Lower Thames Crossing: Archaeological Evaluation Report for Trial Trenching of Land Parcel 3, Essex*. Report HE540039-BAL-GEN-GEN-REP-HER-00022, Oxford Cotswold Archaeology
- Place Services, 2019 *Lower Thames Crossing Aerial Investigation and Mapping Report*, Essex County Council.
- Wilkinson, T J, 1988 *Archaeology and Environment in South Essex: Rescue Archaeology on the route of the A13 Grays By-pass, 1979/80*. East Anglian Archaeology **42**.

Appendix E Abbreviations and Glossary

ADS Archaeology Data Service. Digital archaeological archive

CDM Construction Design Manual. Health and safety guidance for the construction industry

CPD Continuing Professional Development

CIfA Chartered Institute for Archaeologists

DBA Desk Based Assessment. Detailed assessment of archaeology and other aspects of the historic environment

DCO Development Consent Order

EIA Environmental Impact Assessment. Detailed study of environmental impacts as directed under the The Town and Country Planning (Environmental Impact Assessment) Regulations 2017 following on from EU Directive EIA Directive (85/337/EEC)

ES Environmental Statement. The principal environmental report detailing environmental impacts within an EIA

GPS Global Positioning System

HER Historic Environment Record

LTC Lower Thames Crossing

MCIfA Member of the Chartered Institute for Archaeologists

MoRPHE Management of Research Projects in the Historic Environment

NMP National Mapping Programme. A study of aerial photographs and digitisation of resulting data into GIS. Originally funded by Historic England

OASIS Online Access to the Index of archaeological investigations.

The OASIS project brings together a number of strategic partners: the Archaeology Data Service, Historic England, Historic Environment Scotland, and the Royal Commission on the Ancient and Historical Monuments of Wales under the umbrella of the University of York

OCN Old County Number. Historic England's reference for material that is not readily available online and may represent historic archaeological work that consists of paper archives or has yet to be formally reported on

PINS Planning Inspectorate

RAMS Risk Assessment Method Statement

SMC Scheduled monument consent

TDR Trusted Digital Repository

UKIC United Kingdom Institute for Conservation

WSI Written Project of Investigation. A detailed method statement for archaeological work

WSL – Western Southern Link

The Western Southern Link (WSL) is an alternative for Short List Routes 2, 3 and 4 to the south of the River Thames.

Appendix F Site Summary Details

Site name:	Lower Thames Crossing: Land Parcels 24, 25, 26, 28 and 29, Baker Street, Essex
Site code:	LTC24B20
Grid Reference	NGR 563334 180597
Type:	Evaluation
Date and duration:	19th and 20th March 2020 (Land Parcel 25), 11th August and 9th September 2020 (Land Parcels 26 and 28-29) and 11 th and 14 th May 2021 (Land Parcel 24)
Area of Site	18.4ha

Location of archive:

The archive from Land Parcels 24, 25, 26, 28 and 29 will form part of the overall trial trenching scheme archive. This will be deposited in a repository consistent with the standards required by the Museums and Galleries Commission following completion of the archaeological phase of this project. This may either be with the local receiving museum in Thurrock or, if no such repositories are available, with a repository for the whole project designated by LTC. LTC retain the overall responsibility for the successful deposition of the project archive.

Currently, the archive is held at Oxford Archaeology's head office, Janus House, Osney Mead, Oxford, Oxfordshire, OX2 0ES. Oxford Archaeology will store the archive for LTC for a maximum period of 2 years following the completion of the project. If the storage of the archive at OA's office extends past this period, an extension to the storage period and final deposition timetable will be reviewed by OA and LTC and agreed with the major stakeholders.

Summary of Results:

Oxford Cotswold Archaeology was commissioned by Balfour Beatty to undertake a trial trench evaluation of Land Parcels 24-29 of the Lower Thames Crossing Pre-Enabling Works. The land parcels are located directly south-west of the hamlet of Baker Street and north-east of the suburbs of Grays within the county of Essex and Thurrock unitary authority (NGR 563334 180597). At the time of fieldwork only Land Parcels 24, 25, 26, 28 and 29 were available for trenching. The evaluation comprised the excavation of 145 trenches and was completed between 19th and 20th March 2020 (Land Parcel 25), 11th August and 9th September 2020 (land Parcels 26 and 28-29), and 11th and 14th May 2021 (Land Parcel 24).

The evaluation confirmed the presence of a circular cropmark ring ditch in Land Parcel 28, which contained much of a single vessel dated to the later Bronze Age or (more likely) the early Iron Age. The absence of cremated remains may indicate that this ditch was more likely to have surrounded a roundhouse than to have originated as a burial monument. Two undated curvilinear gullies within 50m may have formed part of smaller enclosures. Small ring ditches were revealed in Land Parcel 24, along with a small number of other dated features: a pit and a ditch. Pottery dates these features to the late Bronze Age to early Iron Age period.

The cropmark ditch system aligned NNW-SSE by WSW-ENE in Land Parcel 28 was confirmed by evaluation, and was more extensive than indicated by the cropmarks, but had

insufficient finds to date it. In Land Parcel 29 a further ditch system on the same alignments was found, one ditch containing a brick fragment of late medieval or early post-medieval date. This ditch was in line with one of the ditches in Land Parcel 28, and they were probably both parts of one wider field system. Some ditches corresponded with the extant western field boundary of Land Parcel 26, which a tithe map and early Ordnance Survey maps show was then part of a system of smaller fields to the north. The evidence suggests that evaluated ditch is a still earlier system of early post-medieval or (just possibly) late medieval origin.

A regular alignment of large, discrete cropmarks in Land Parcel 28 was shown to consist of natural features.

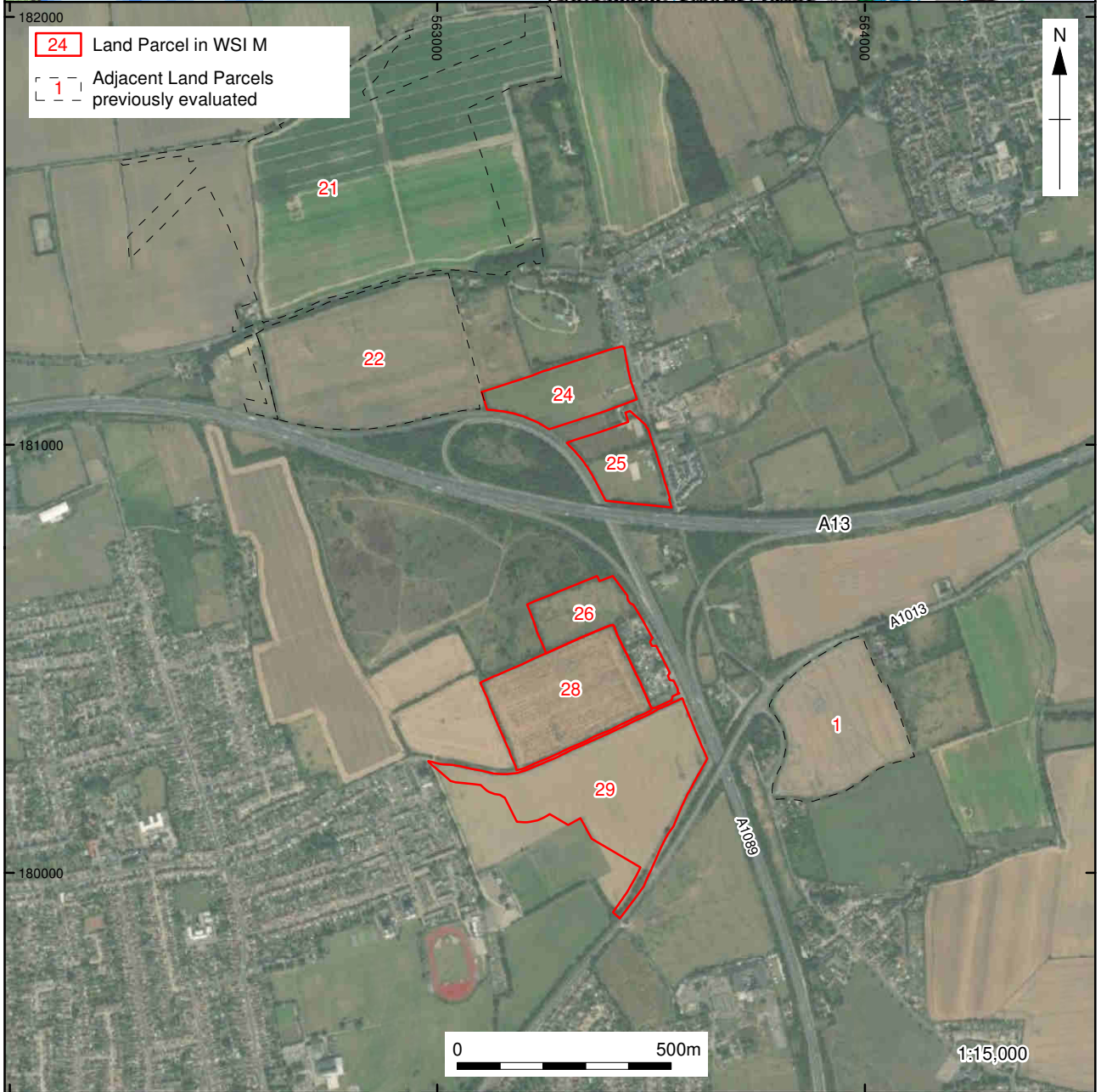
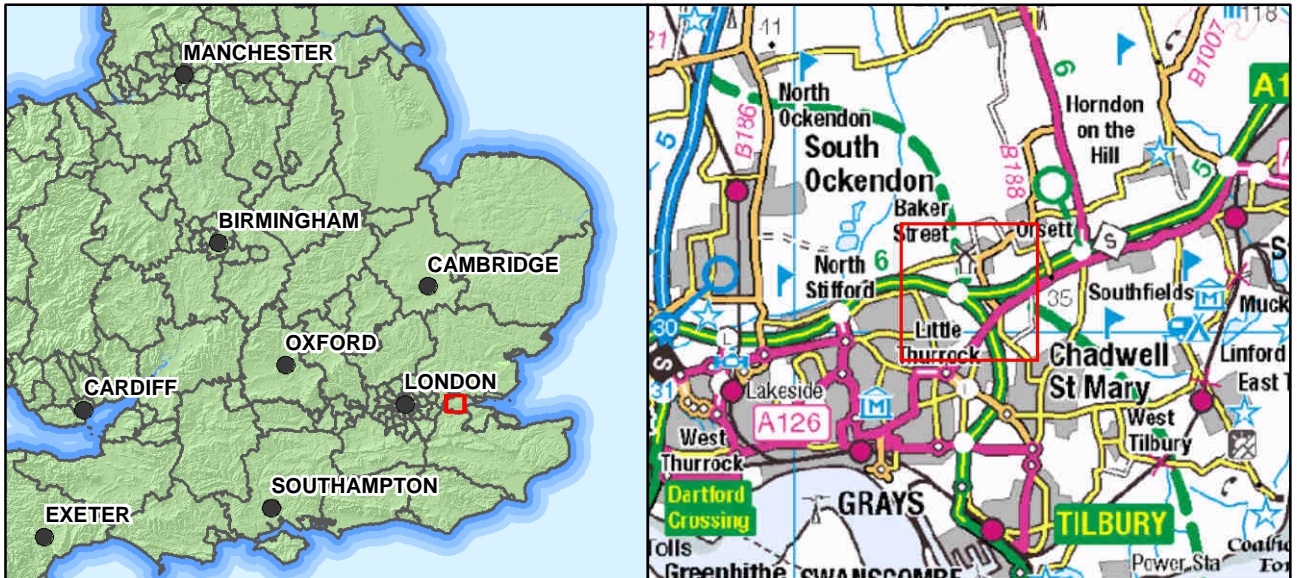

X:\MLTCEV_Lower_Thames_Crossing\010Geomatics\03 GIS Projects - LTC24B20\LTC Reports\LTC_Report_Fig1.mxd\gary.jones*19/11/2020

Source: Esri, Maxar, GeoEye, Earthstar Geographics, CNES/Airbus DS, USDA, USGS, AeroGRID, IGN, and the GIS User Community
Contains Ordnance Survey data © Crown copyright and database right 2016

Figure 1: Map showing the location of Land Parcels 24-29

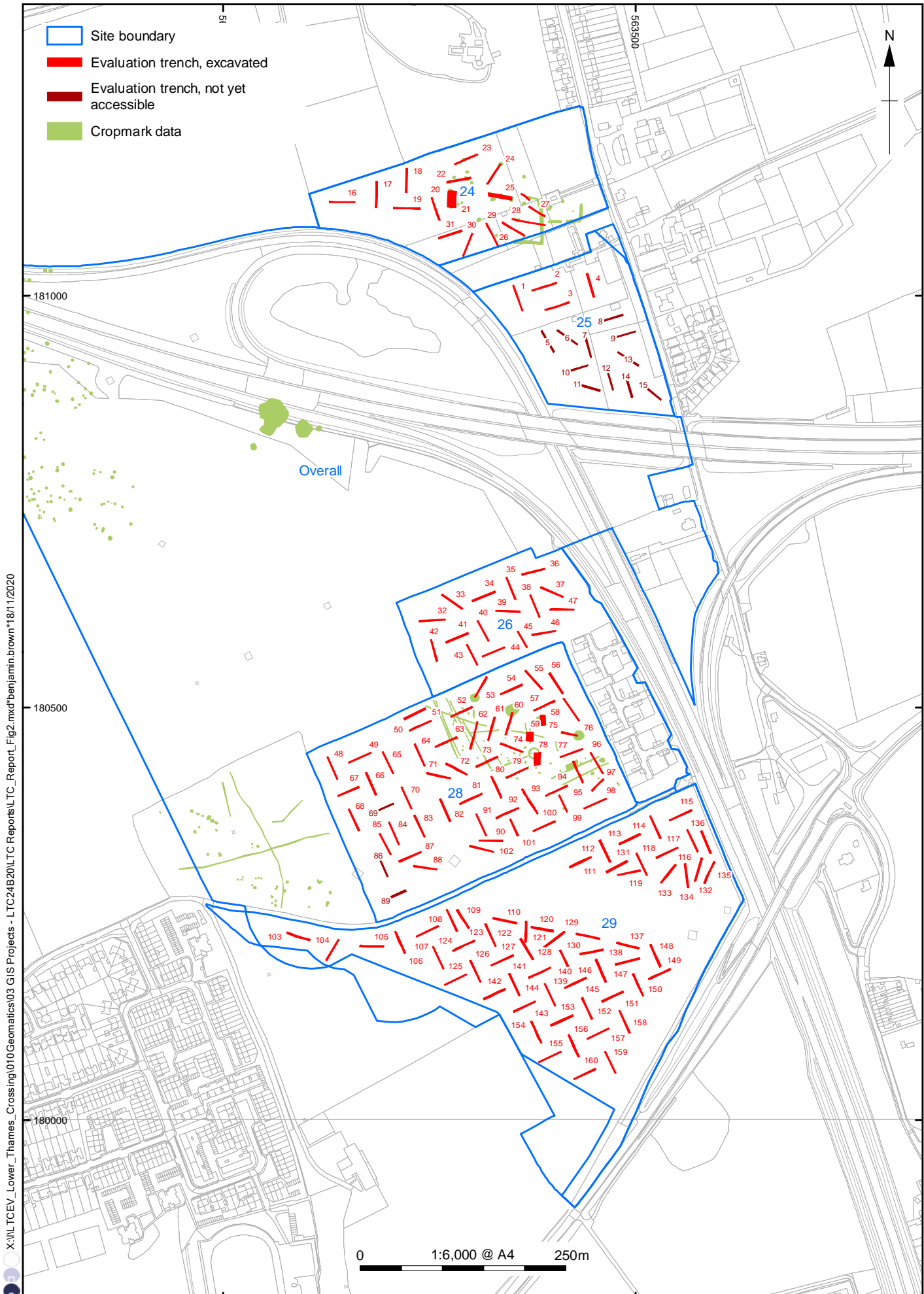

Contains Ordnance Survey data © Crown copyright and database right 2020, provided by client

Figure 2 : Trench layout and cropmark features

X:\ILTCEV_Lower_Thames_Crossing\010Geomatics\03 GIS Projects - LTC24B20\LTC Reports\LTC_Report_TrenchPlans_DD_A3_(2021-Additions).mxd*benjamin.brown*28/07/2021

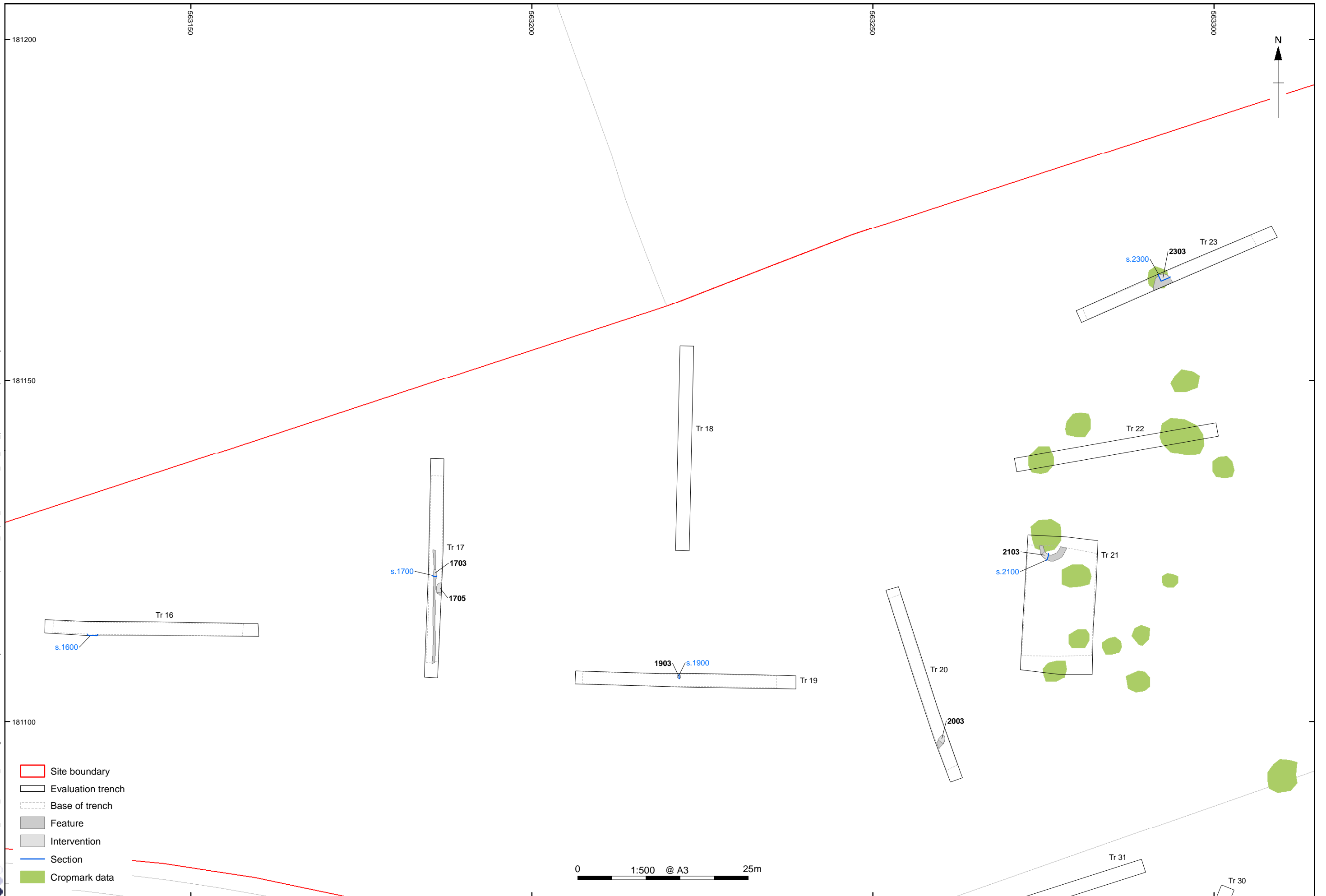

Figure 3: Plan of Trenches 16-20, Land Parcel 24

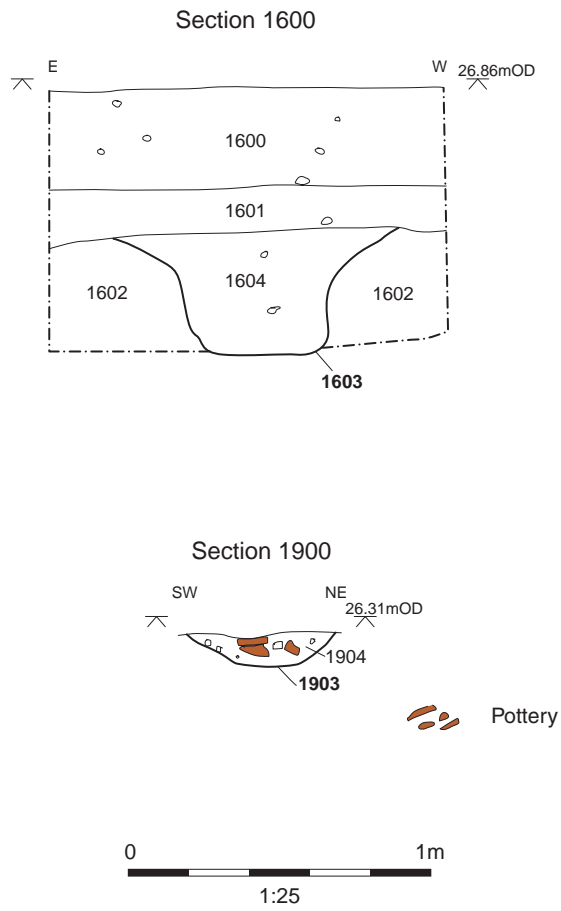

Figure 4: Sections (Trenches 16 and 19)

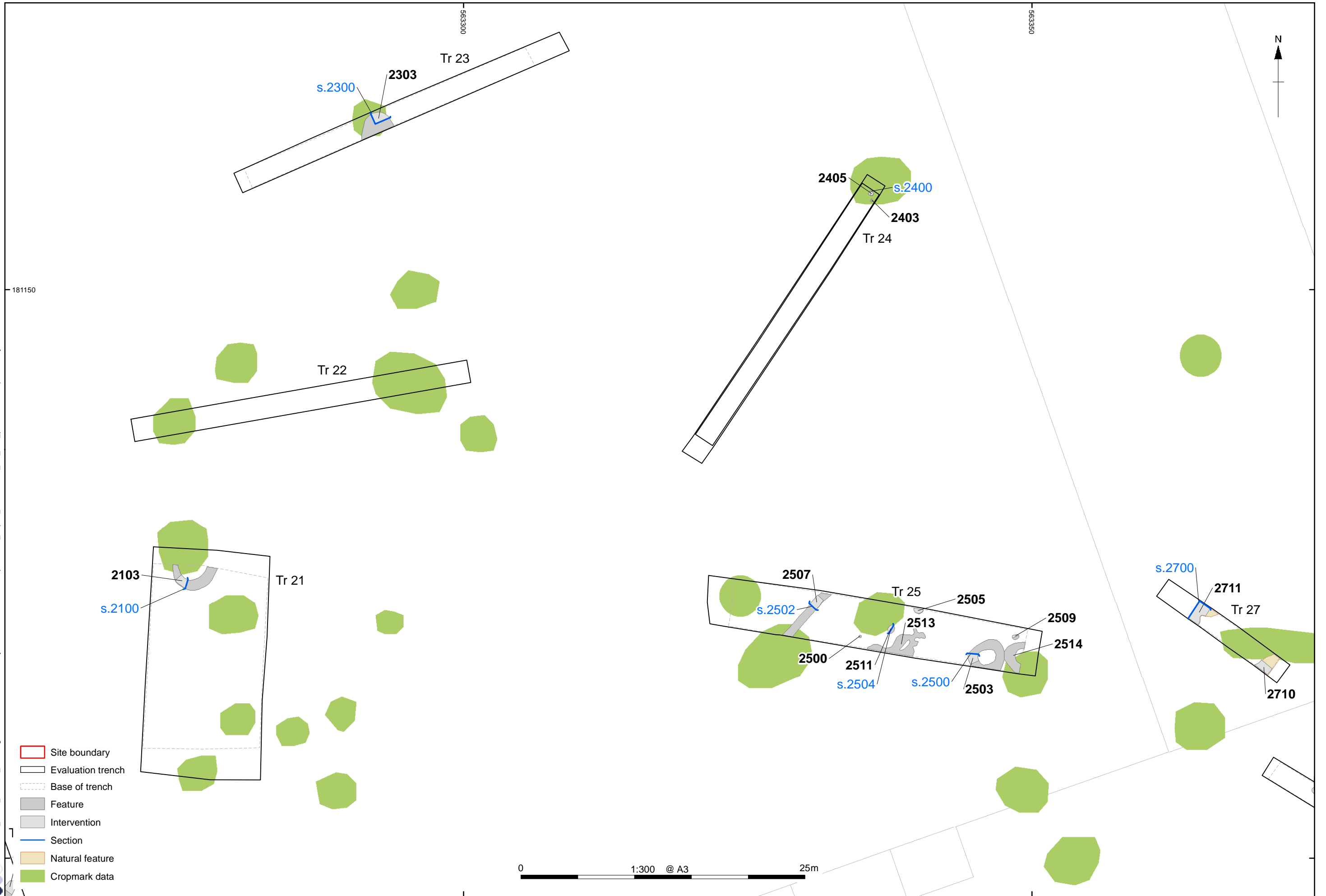

Figure 5: Plan of Trenches 21-25, Land Parcel 24

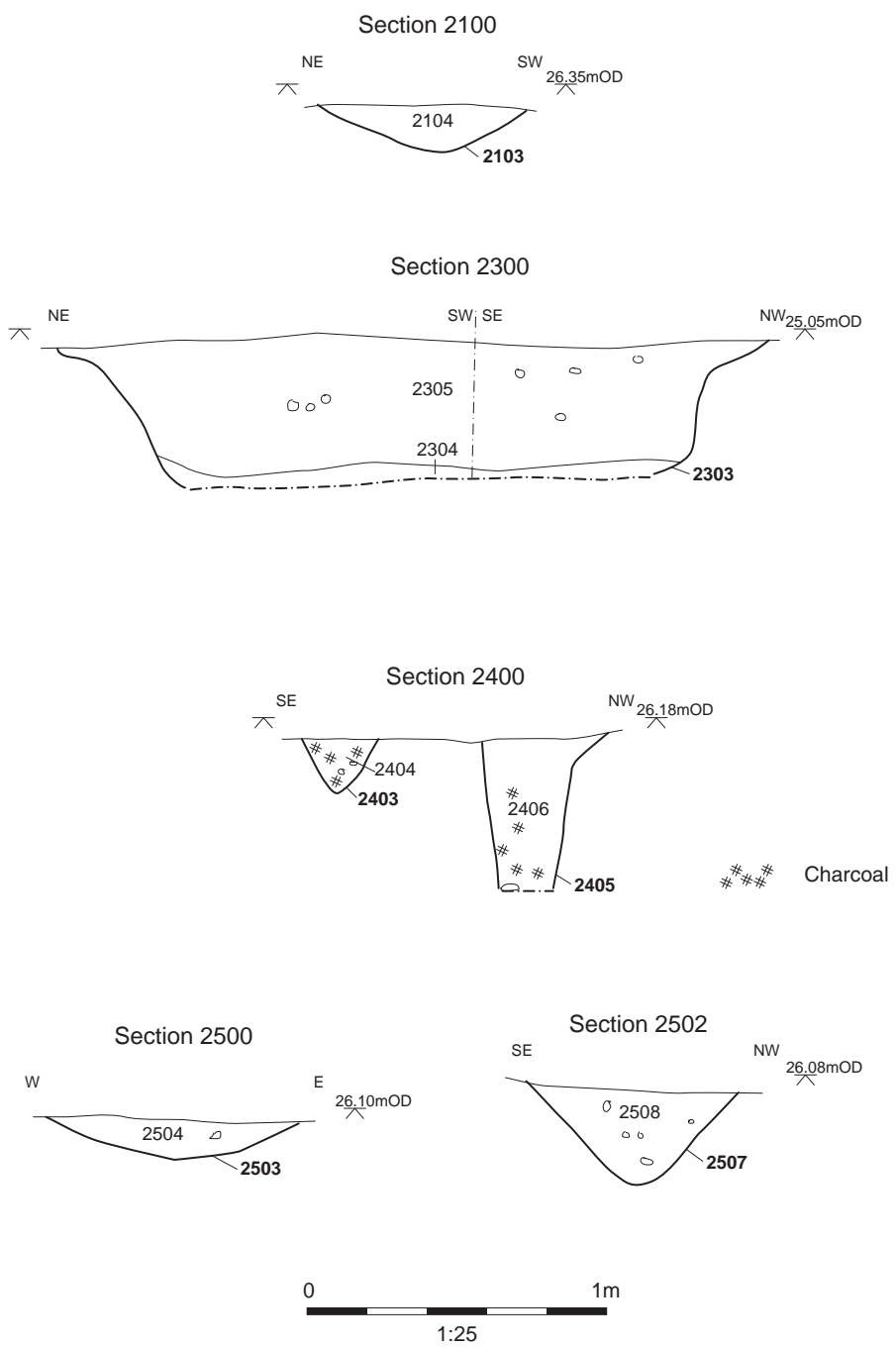
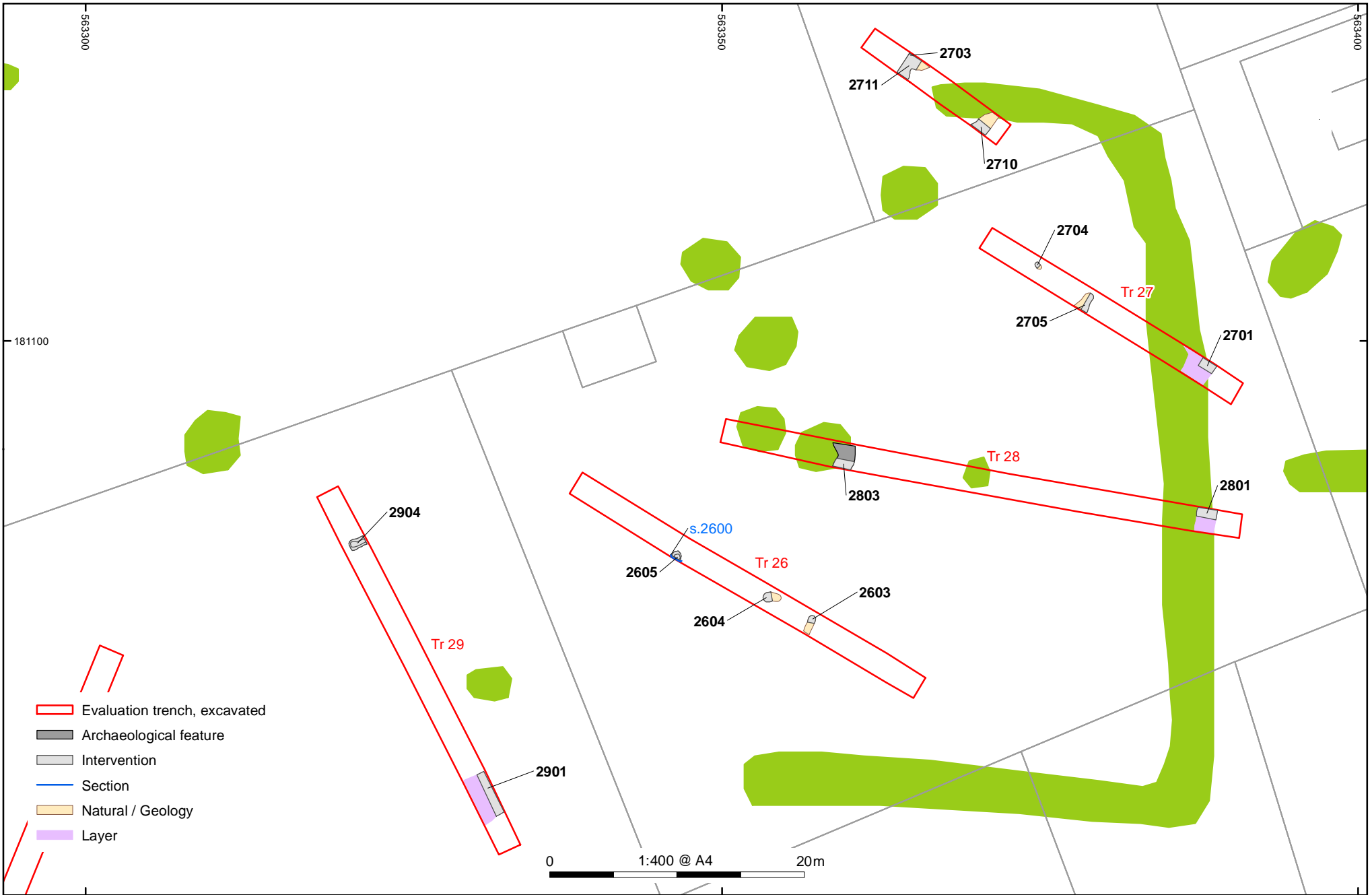

Figure 6: Sections (Trenches 21, 23, 24 and 25)



Contains Ordnance Survey data © Crown copyright and database right 2020, provided by client

Figure 7: Plan of Trenches 26-29, Land Parcel 24

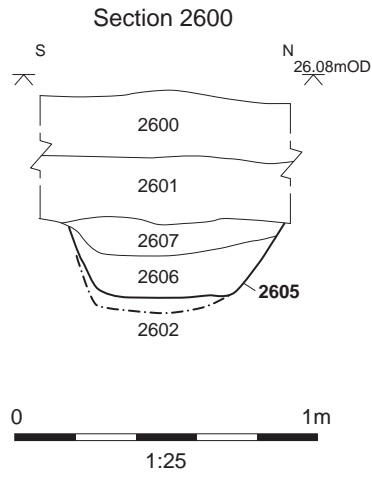

Figure 8: Section (Trench 26)

X:\ILTCEV_Lower_Thames_Crossing\010Geomatics\03 GIS Projects - LTC24B20\LTC Reports\LTC_Report_TrenchPlans_DD_A3_(2021-Additions).mxd*benjamin.brown*28/07/2021

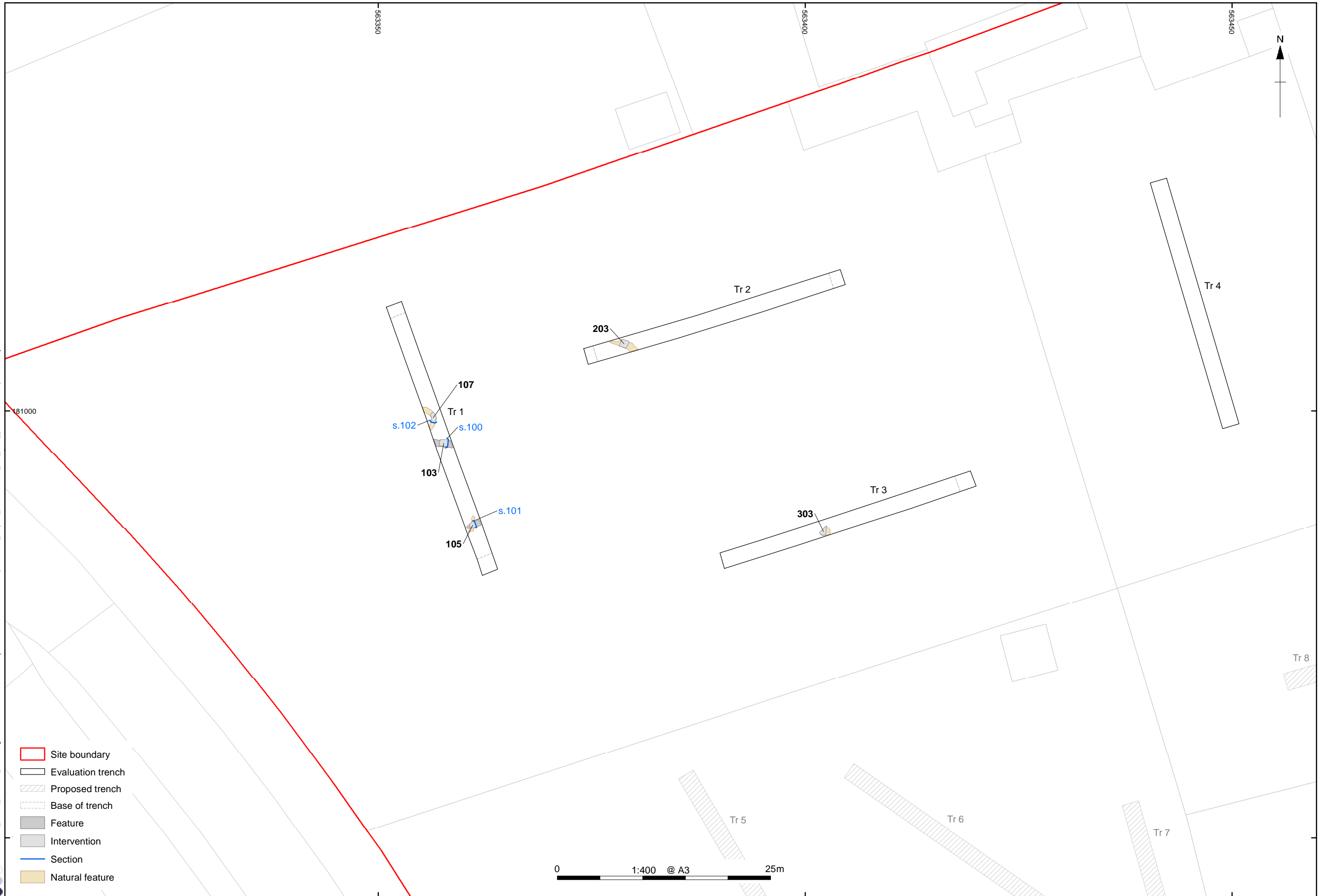

Figure 9: Plan of Trenches 1-4, Land Parcel 25

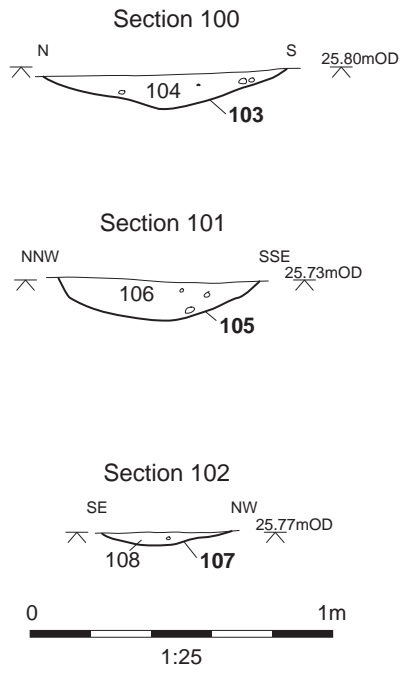

Figure 10: Sections (Trench 1)

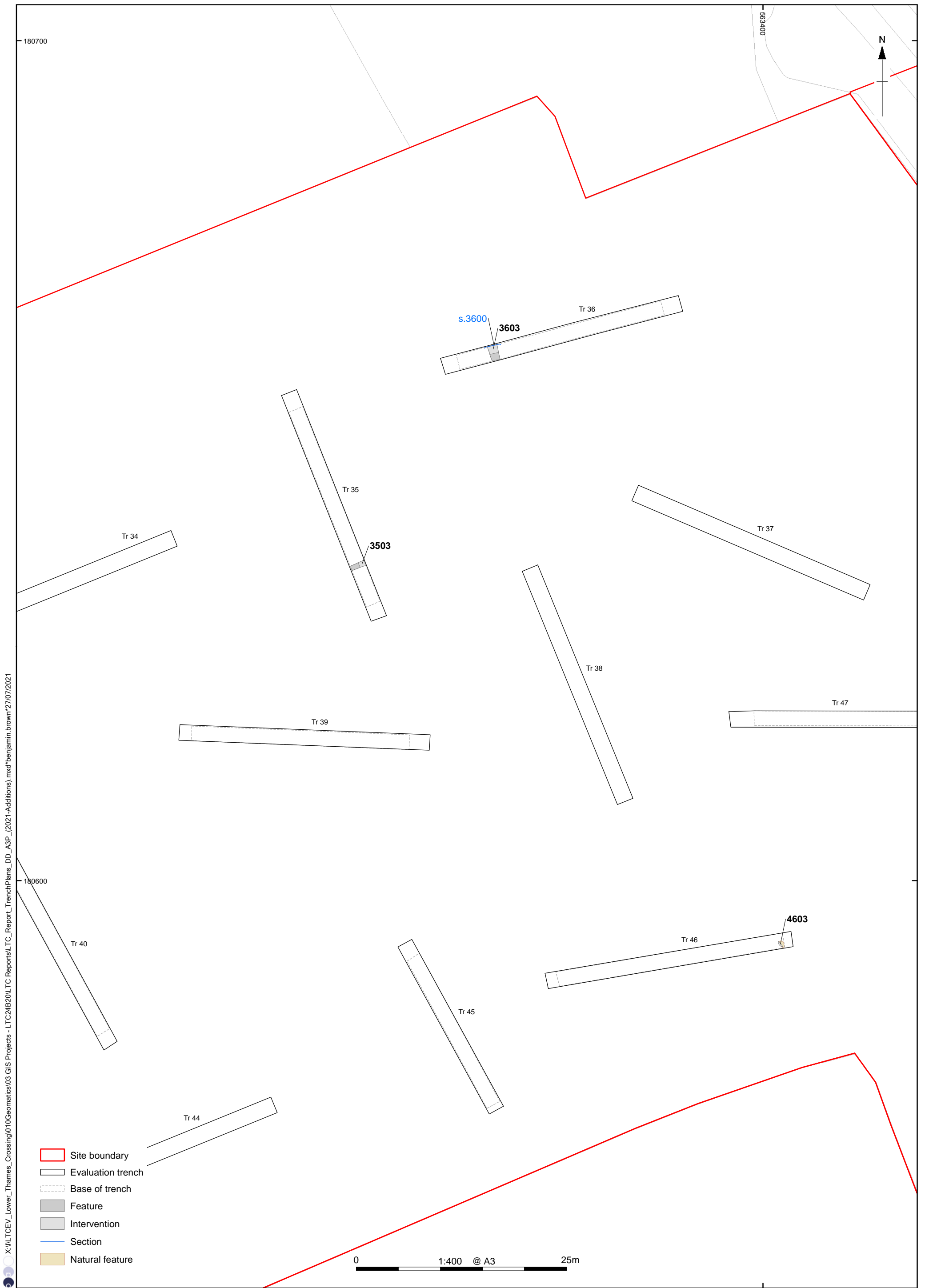

Figure 11: Plan of Trenches 35 and 36, Land Parcel 26

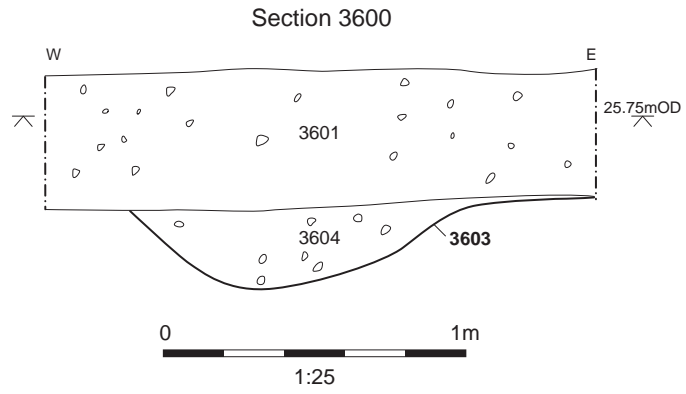

Figure 12: Section (Trench 36)

X:\ILTCEV_Lower_Thames_Crossing\010\Geomatics\03 GIS Projects - LTC24B20\LTC Reports\LTC_Report_TrenchPlans_DD_A3_(2021-Additions).mxd*benjamin.brown*28/07/2021

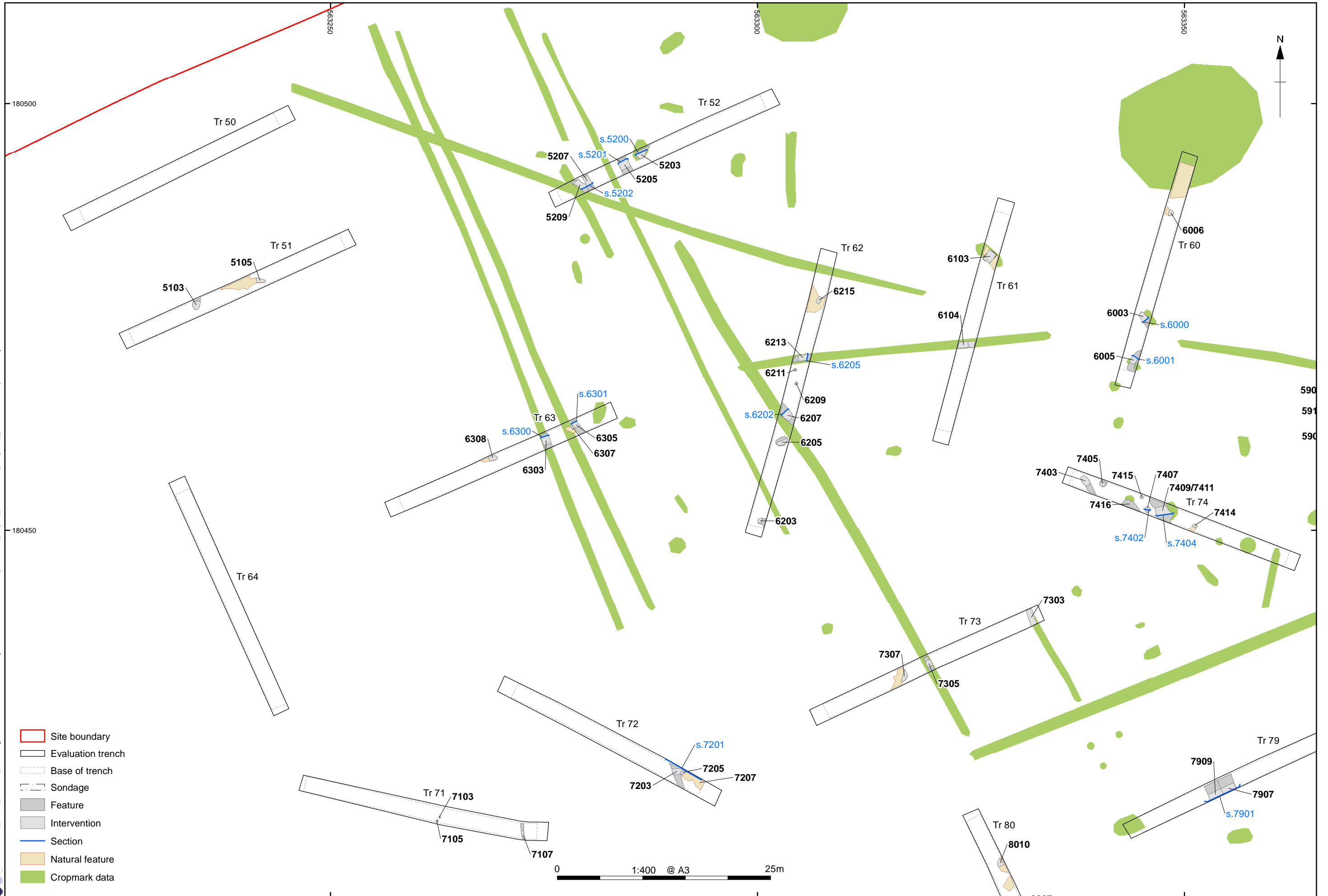

Figure 13: Plan of Trenches 51, 52, 61, 62, 63, 71, 72 and 73, Land Parcel 28

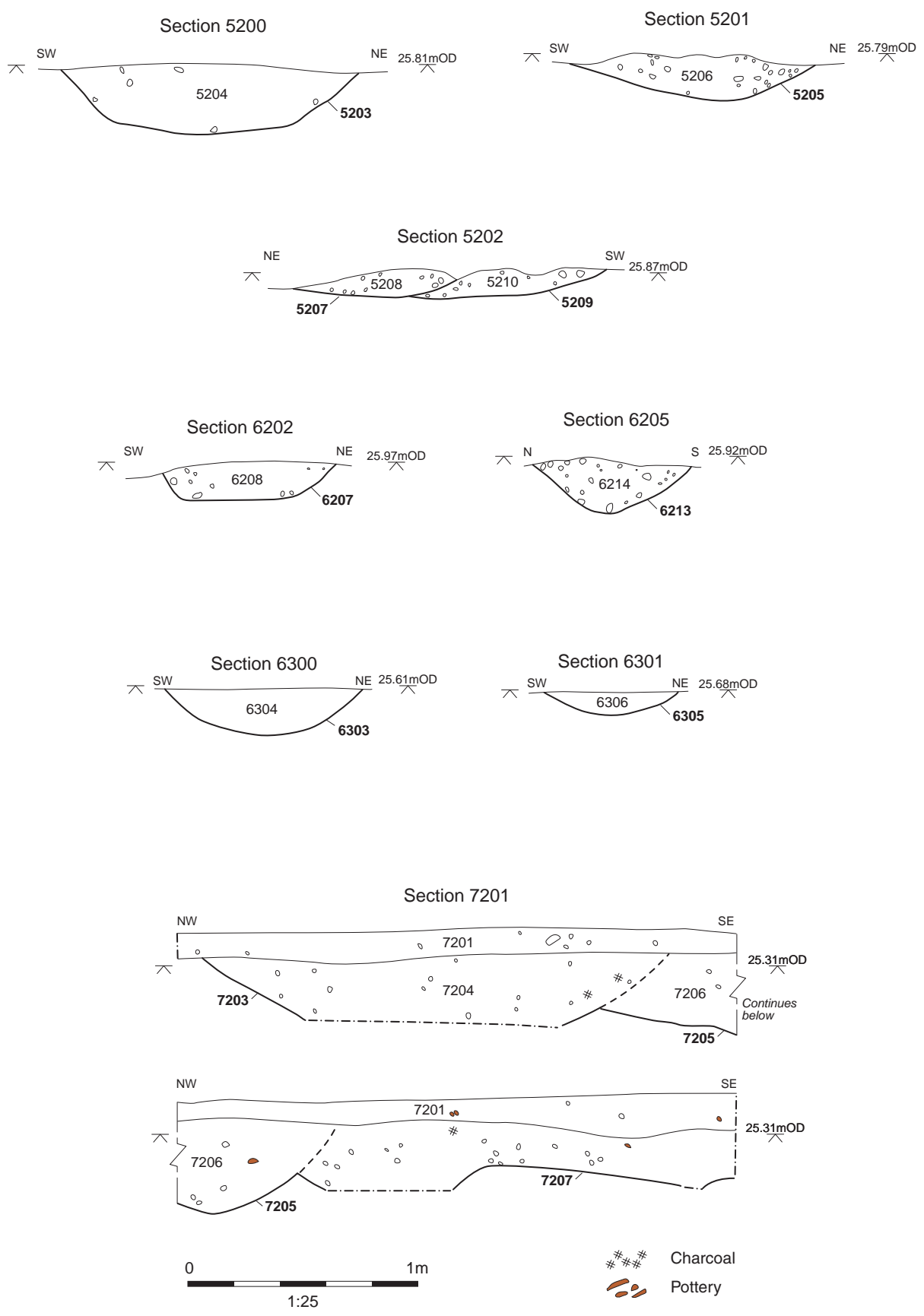

Figure 14: Sections (Trenches 52, 62, 63 and 72)

X:\ILTCEV_Lower_Thames_Crossing\010Geomatics\03 GIS Projects - LTC24B20\TLC Reports\TLC_Report_TrenchPlans_DD_A3_(2021-Additions).mxd*benjamin.brown*28/07/2021

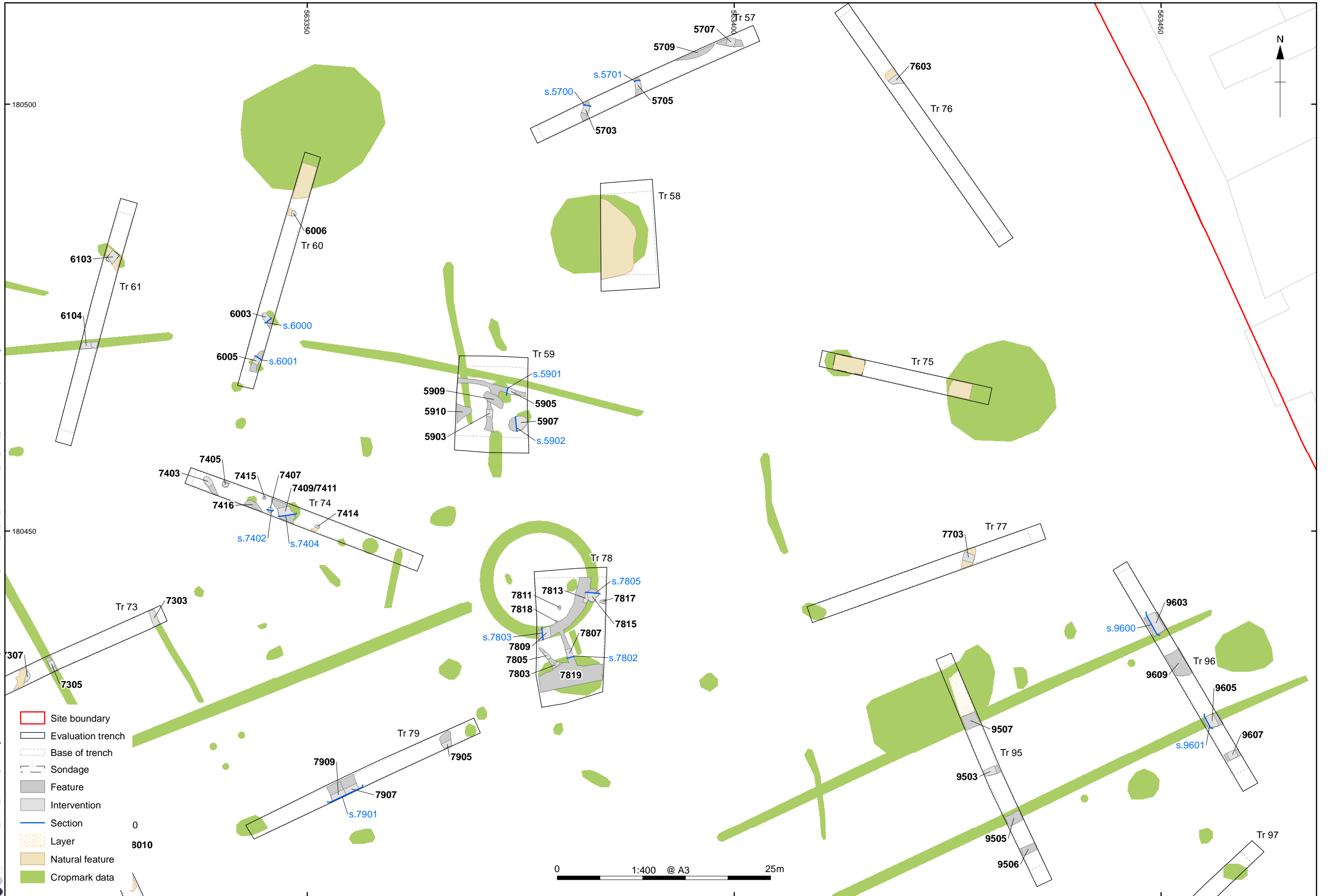

Figure 15: Plan of Trenches 57, 59, 60, 74, 78, 79, 95 and 96, Land Parcel 28

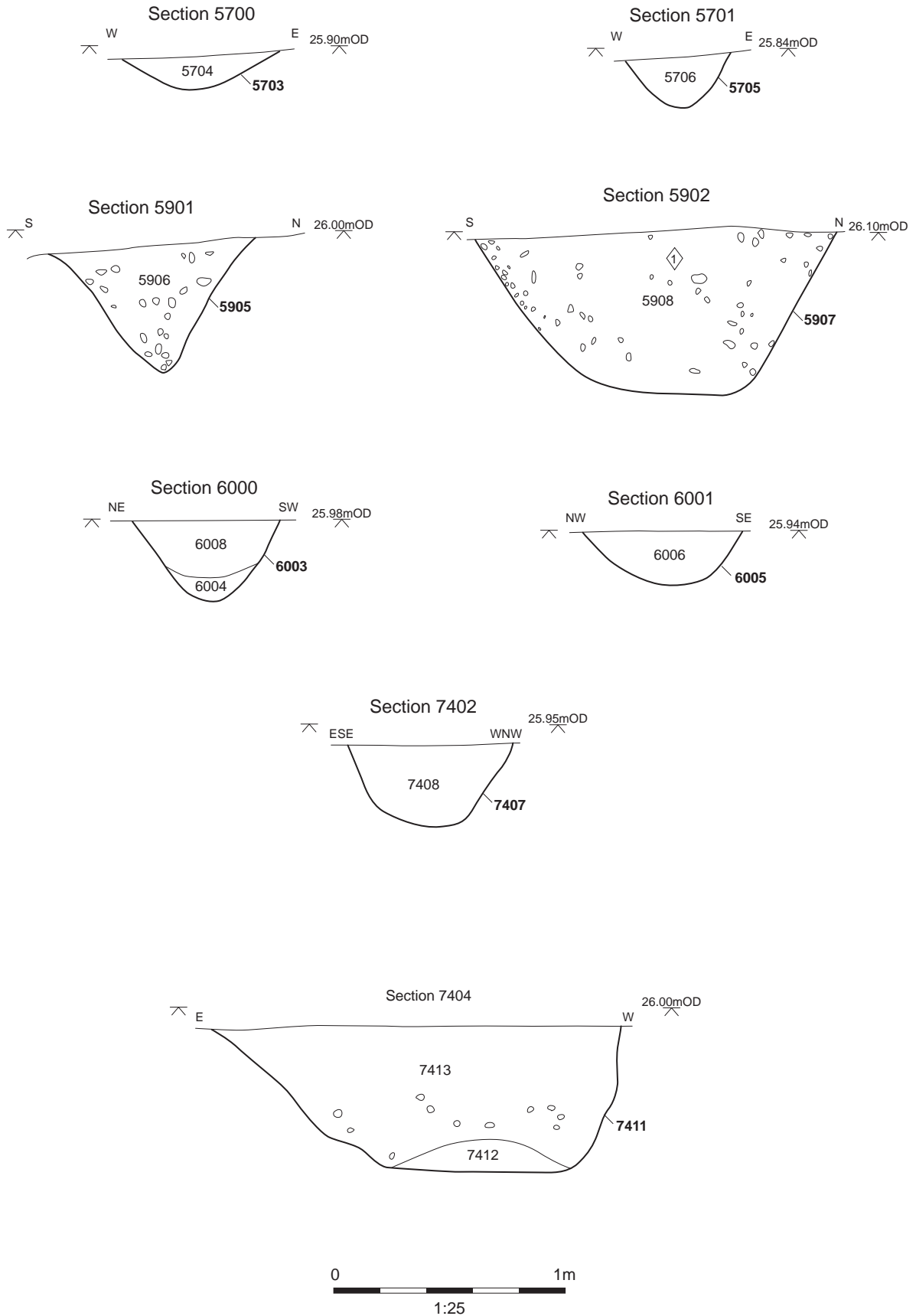

Figure 16: Sections (Trenches 57, 59, 60 and 74)

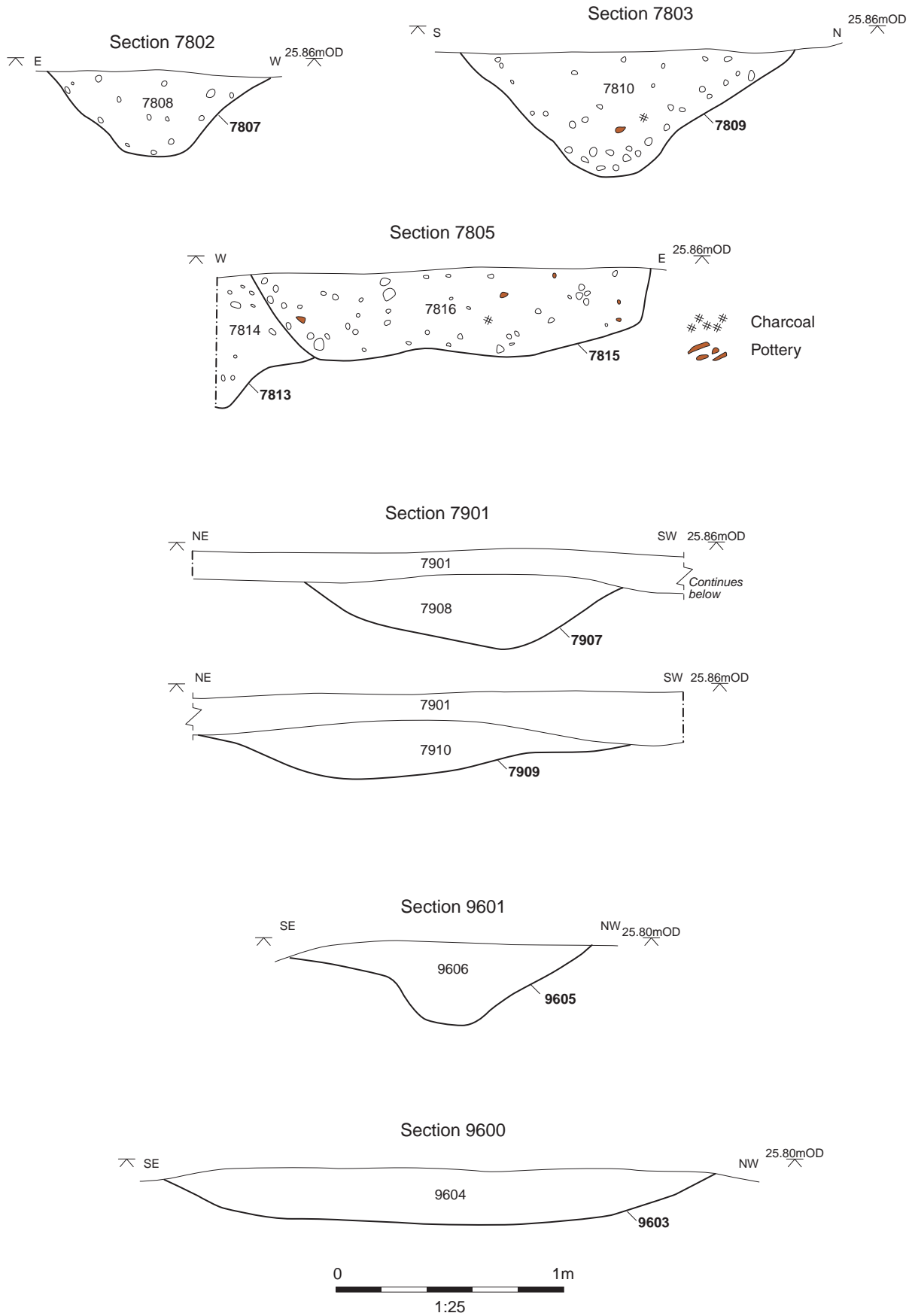

Figure 17: Sections (Trenches 78, 79 and 96)

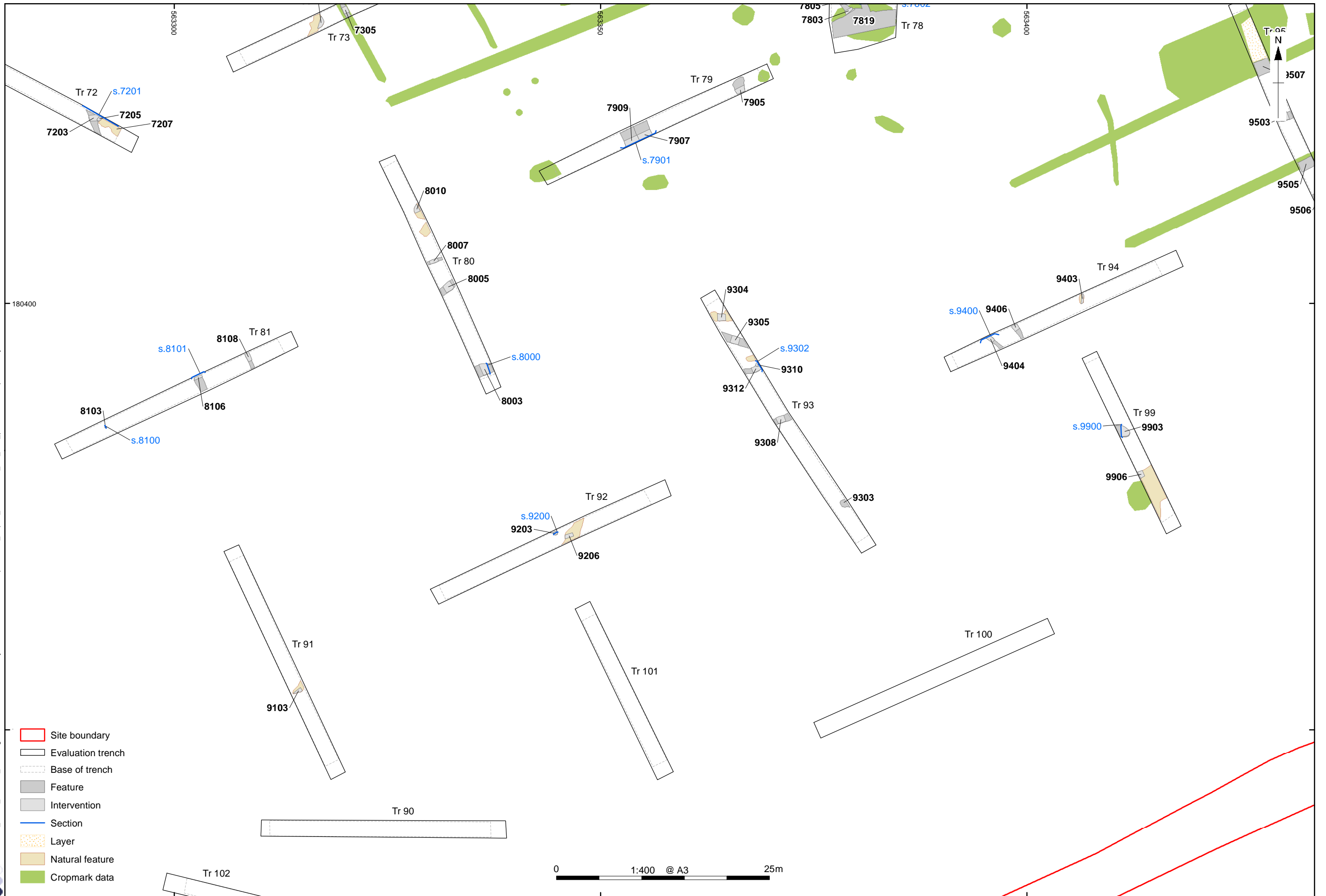

Figure 18: Plan of Trenches 80, 81, 82, 92, 93, 94 and 99, Land Parcel 28

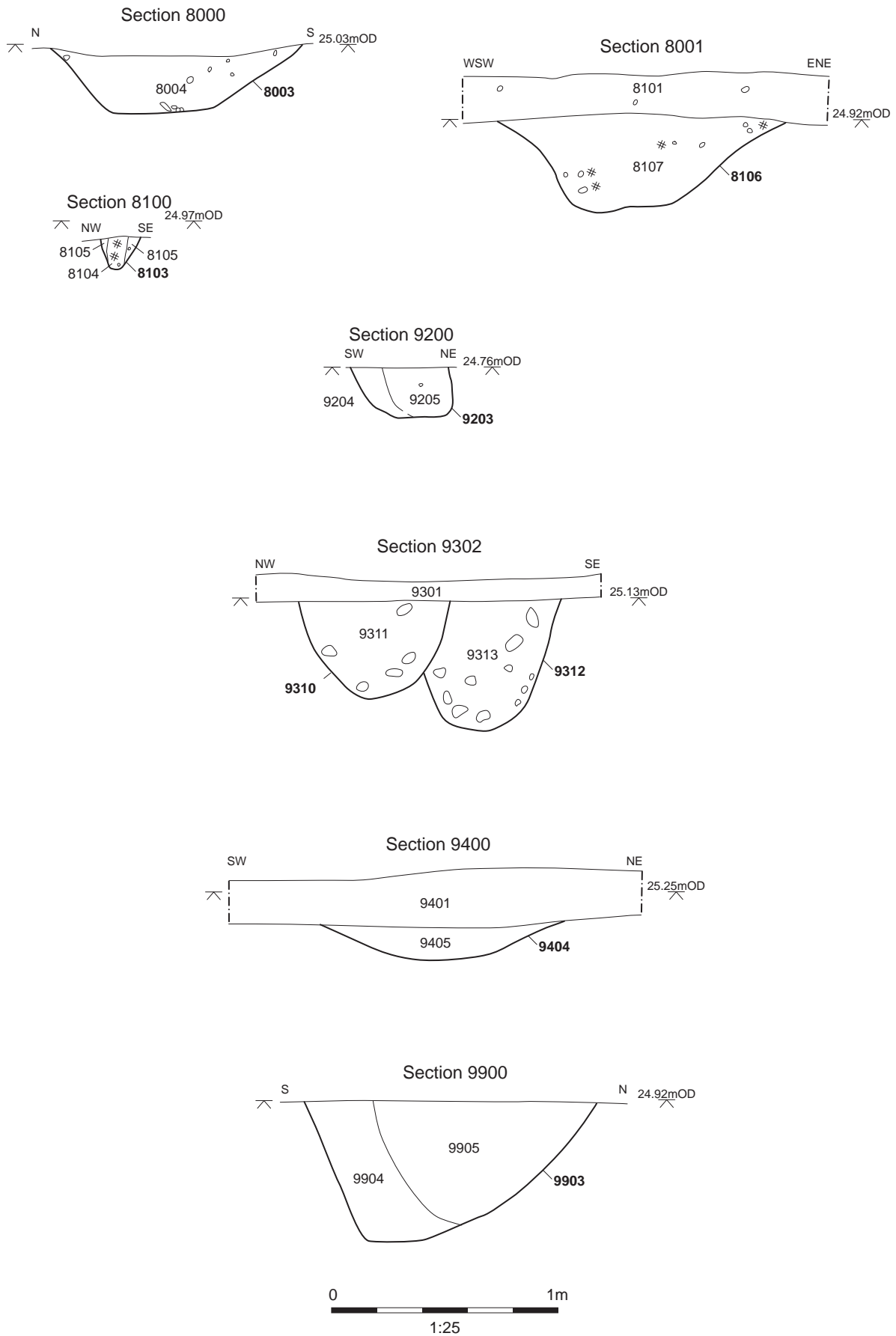

Figure 19: Sections (Trenches 80, 81, 92, 93, 94 and 99)

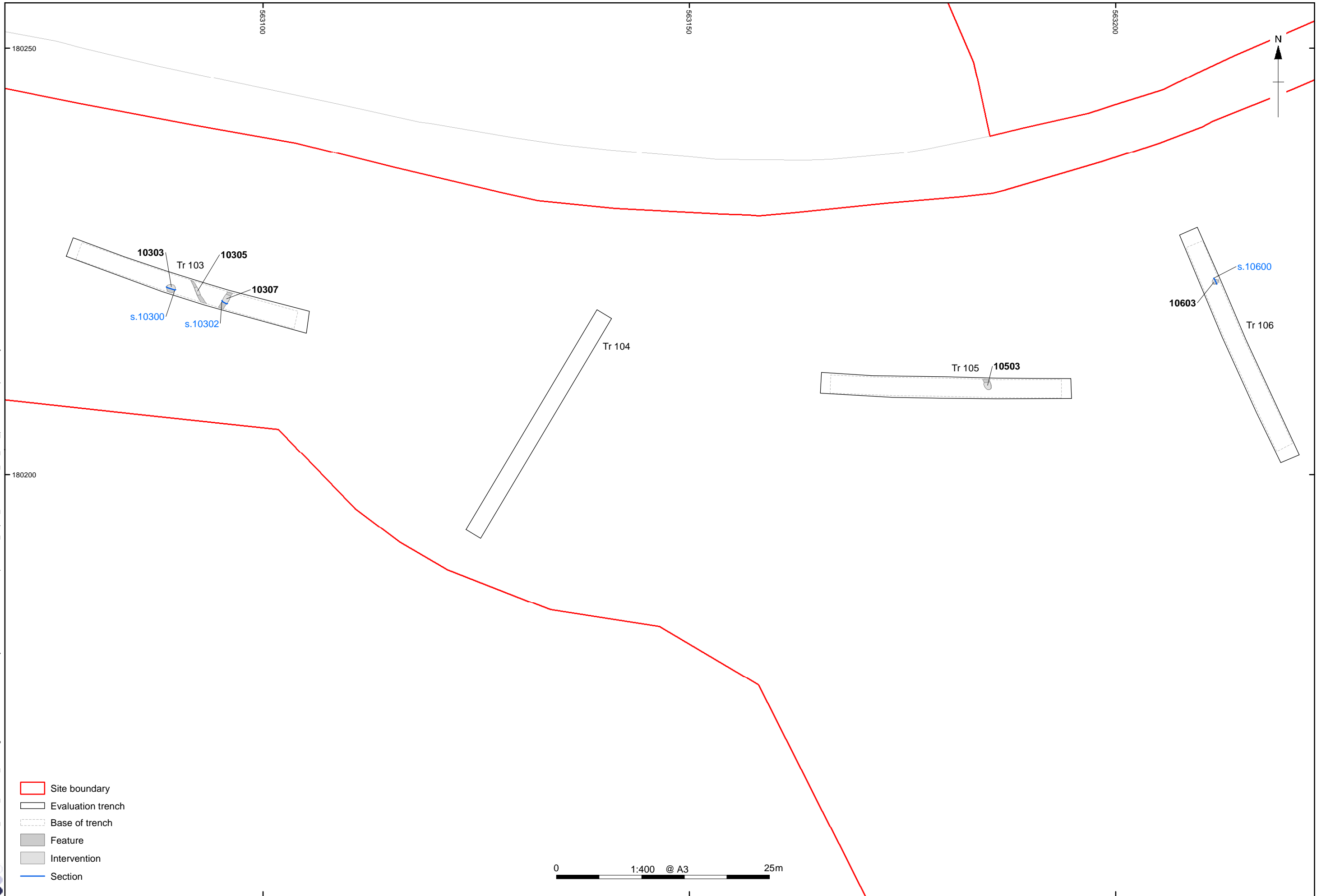

Figure 20: Plan of Trenches 103 and 106, Land Parcel 29

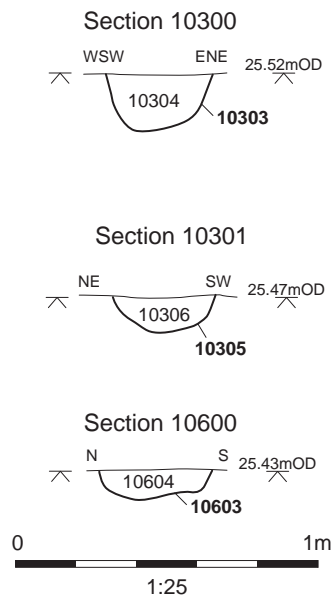

Figure 21: Sections (Trenches 103 and 106)

X:\ILTCEV_Lower_Thames_Crossing\010Geomatics\03 GIS Projects - LTC24B20\LTC Reports\LTC_Report_TrenchPlans_DD_A3_(2021-Additions).mxd*benjamin.brown*28/07/2021

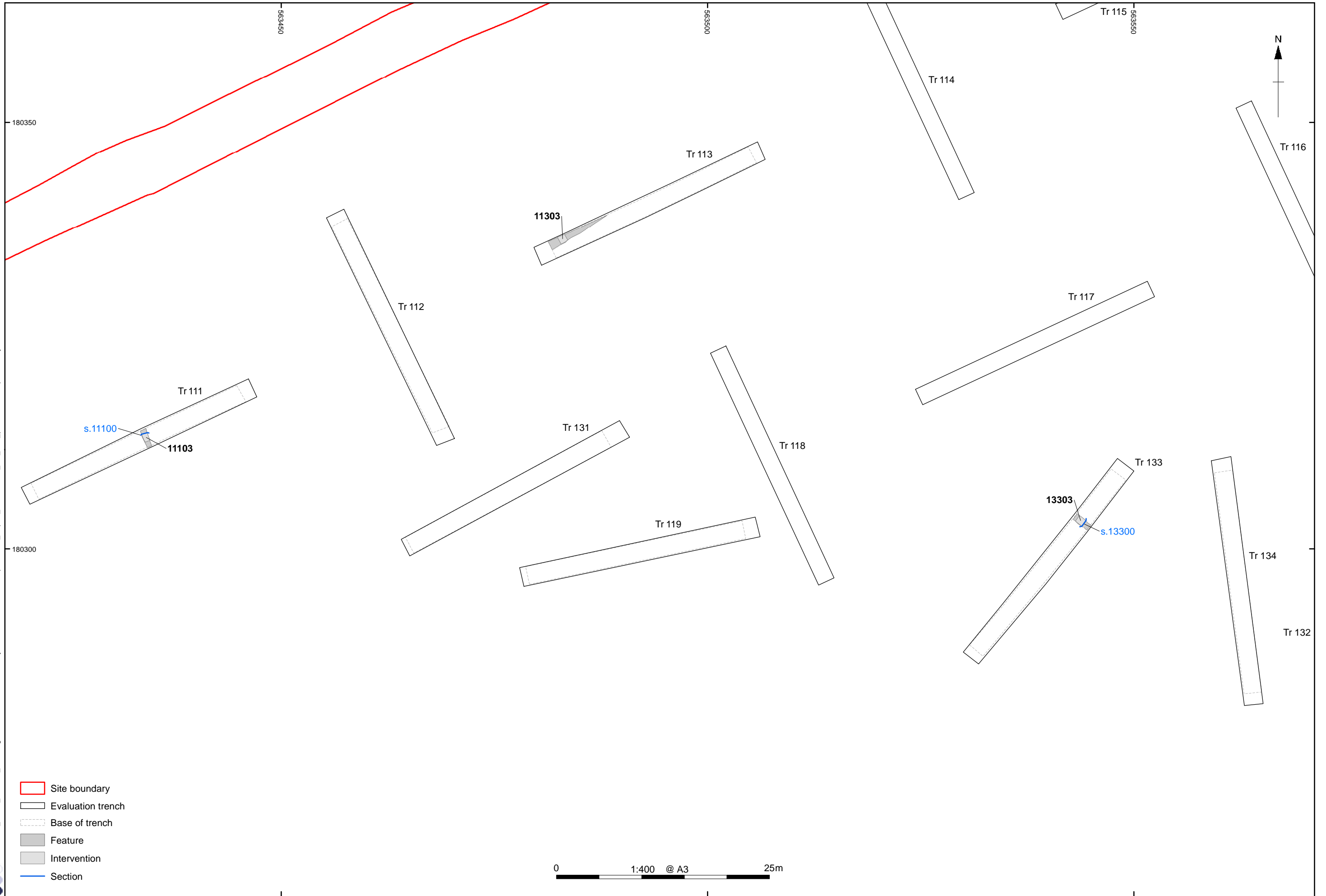

Figure 22: Plan of Trenches 111, 113 and 133, Land Parcel 29

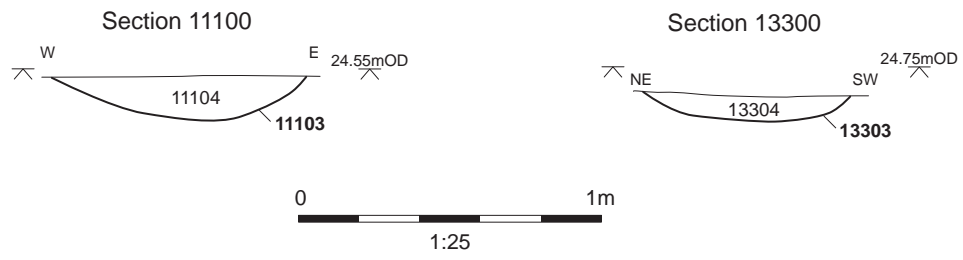

Figure 23: Sections (Trenches 111 and 133)

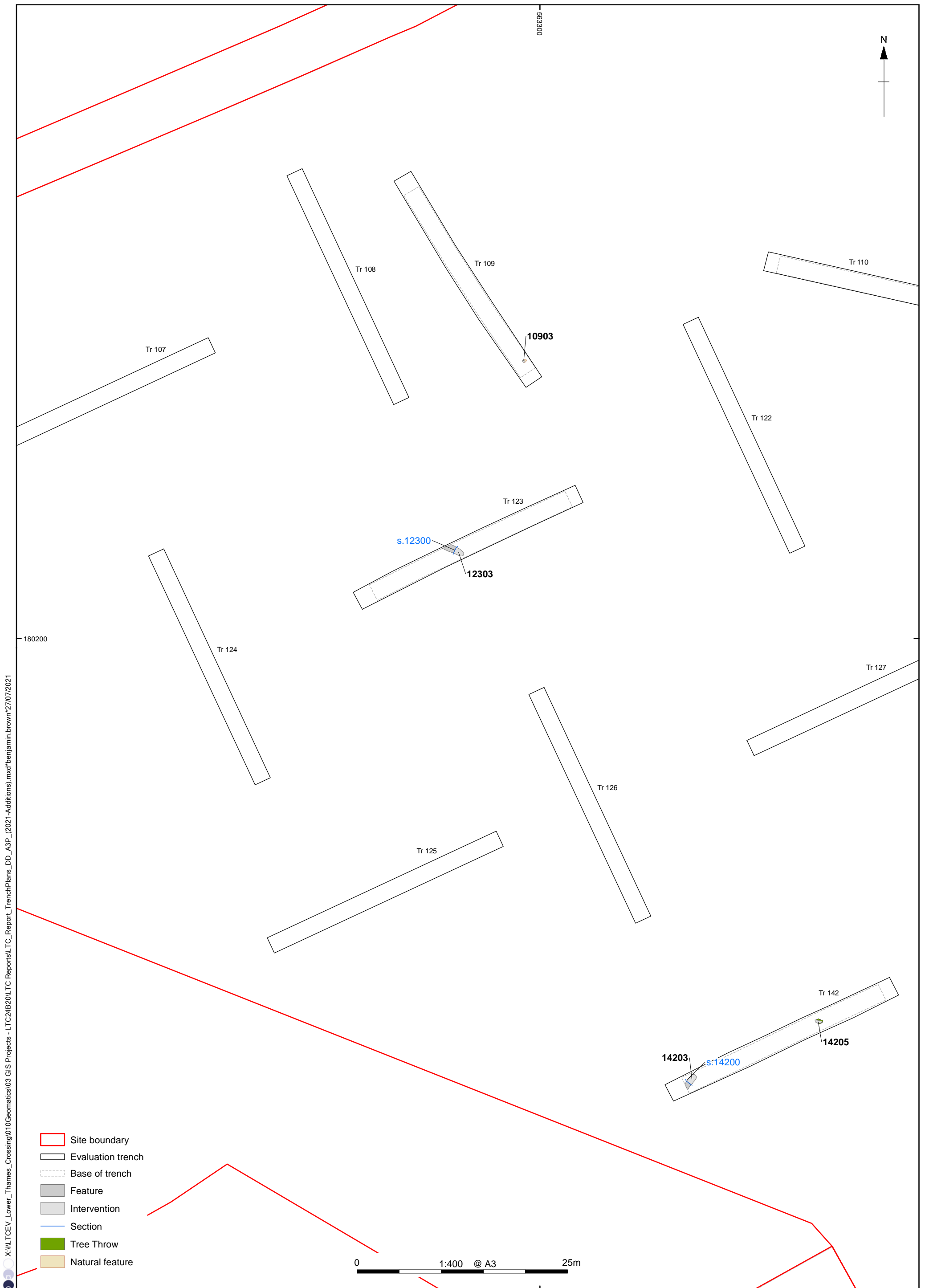

Figure 24: Plan of Trenches 123 and 142, Land Parcel 29

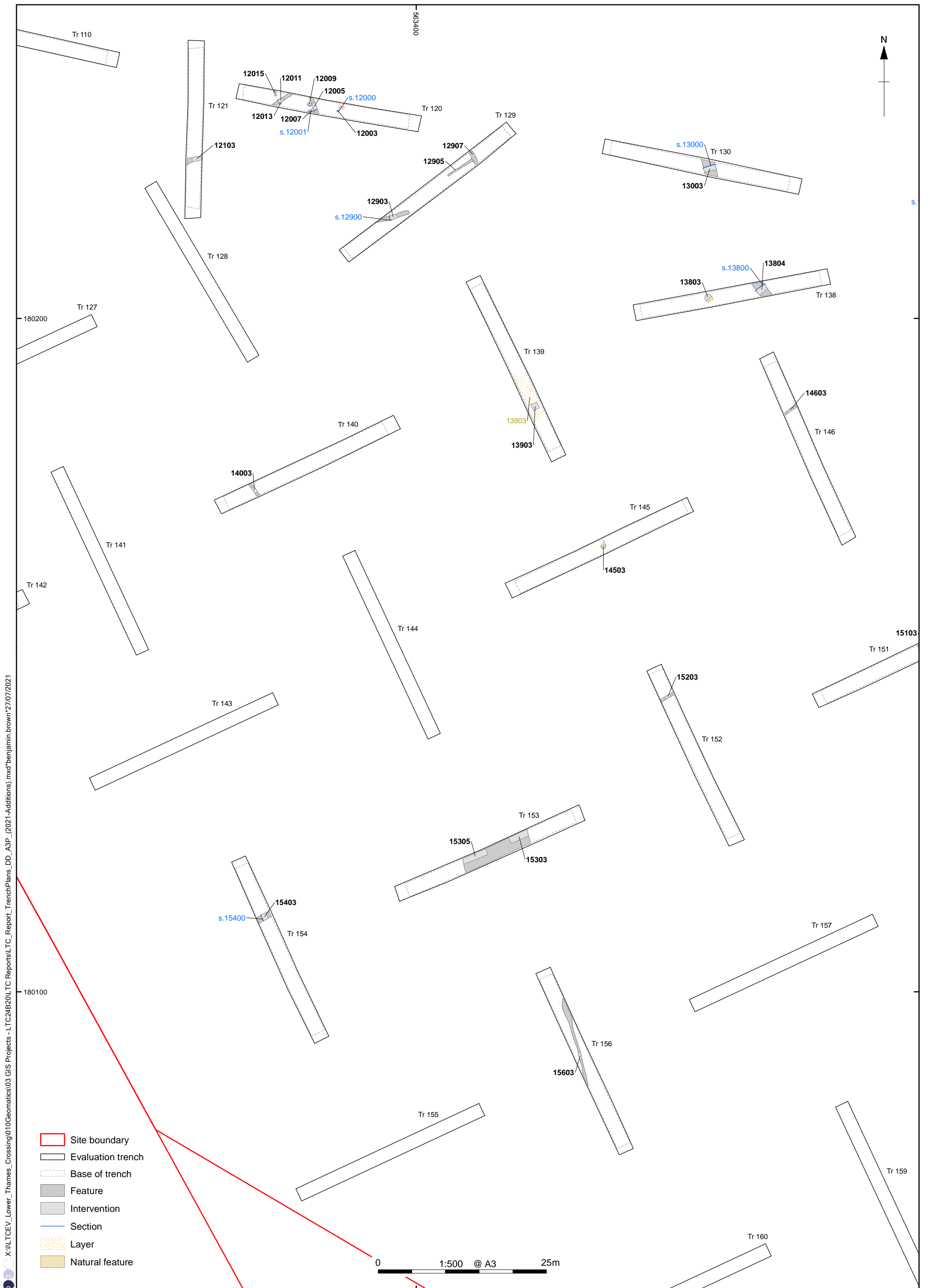

Figure 26: Plan of Trenches 120, 121, 129, 130, 138, 139, 140, 145, 146, 152, 153, 154 and 156, Land Parcel 29

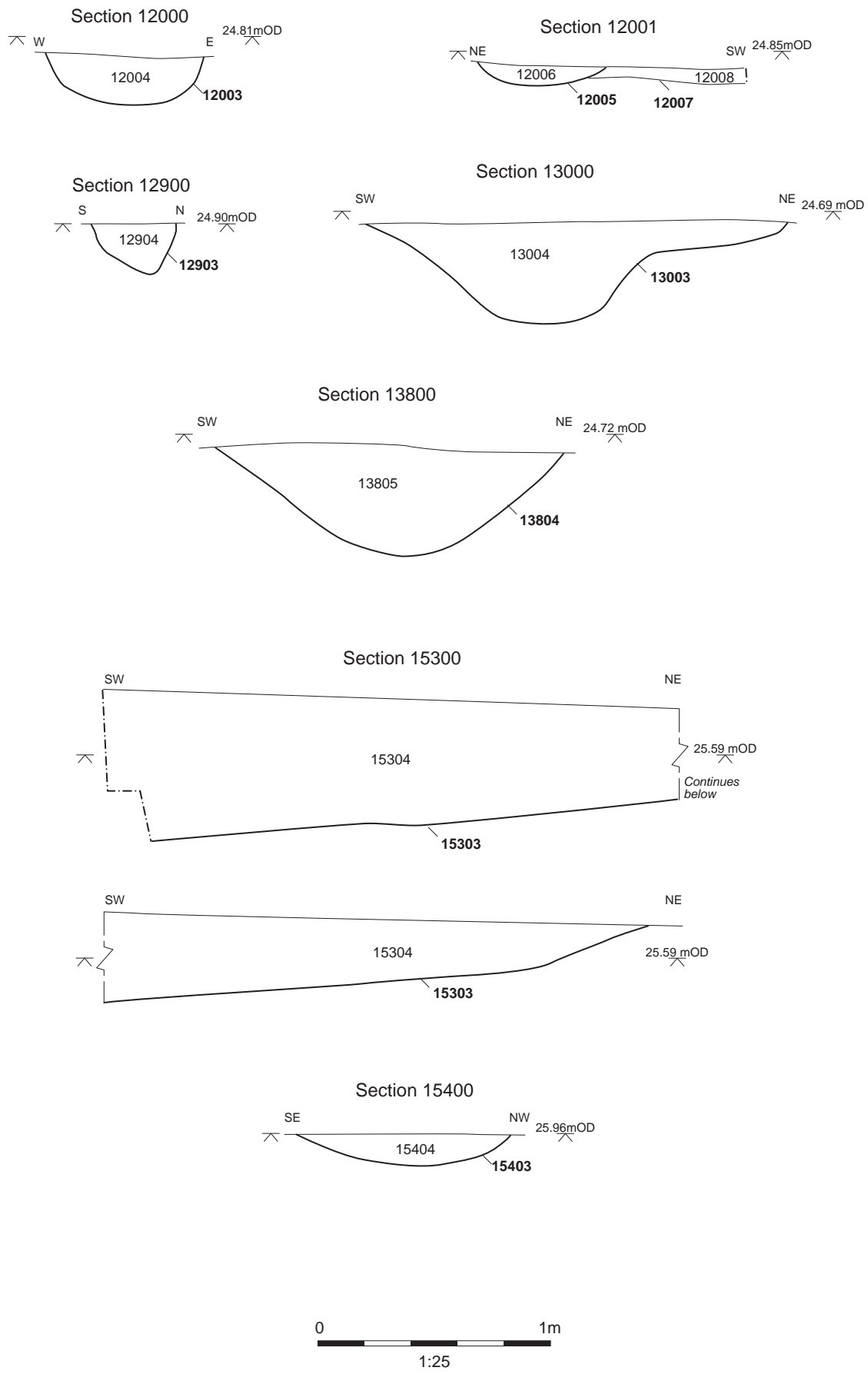

Figure 27: Sections (Trenches 120, 129, 130, 138, 153 and 154)

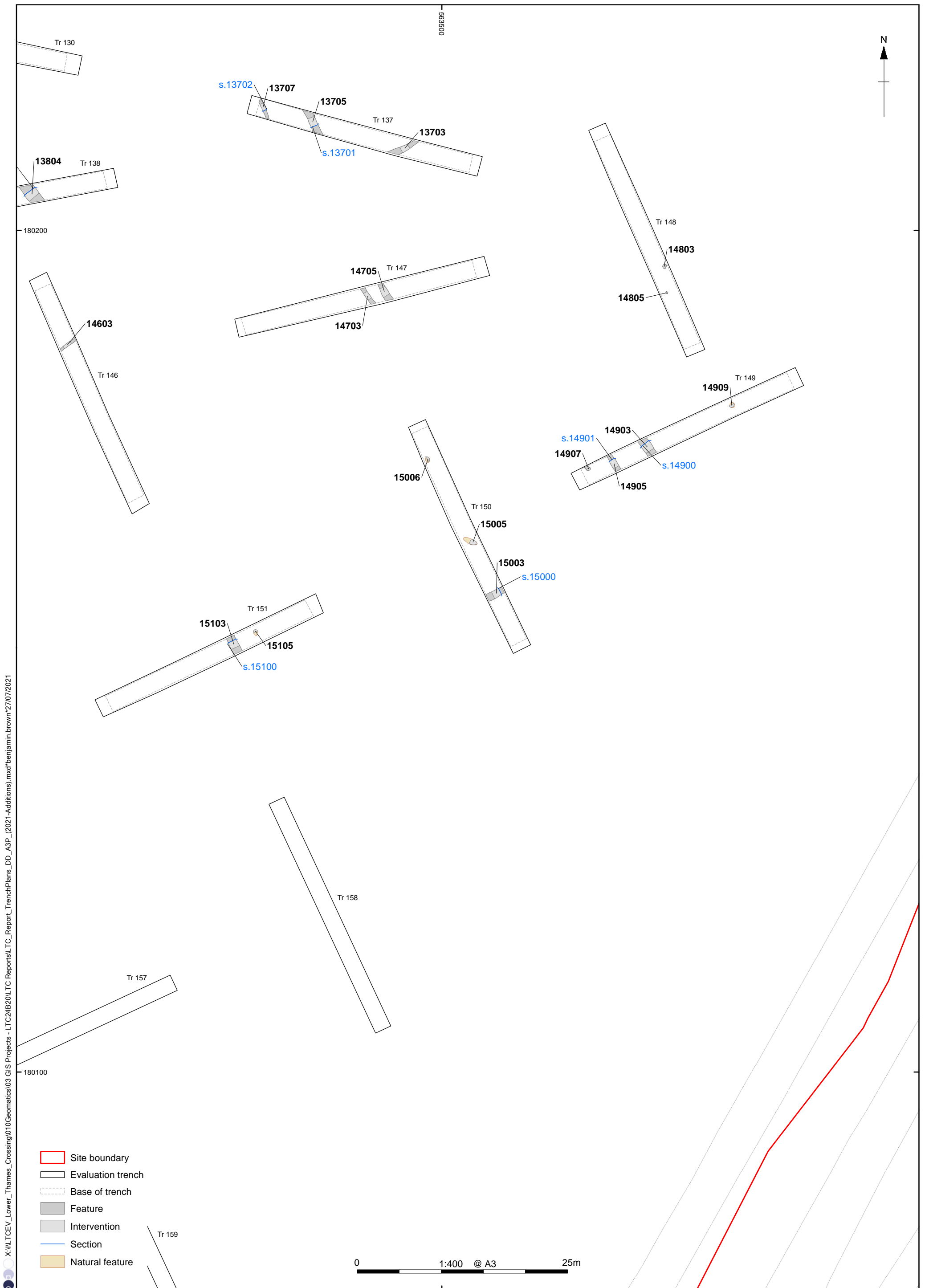

Figure 28: Plan of Trenches 137, 147, 148, 149, 150 and 151, Land Parcel 29

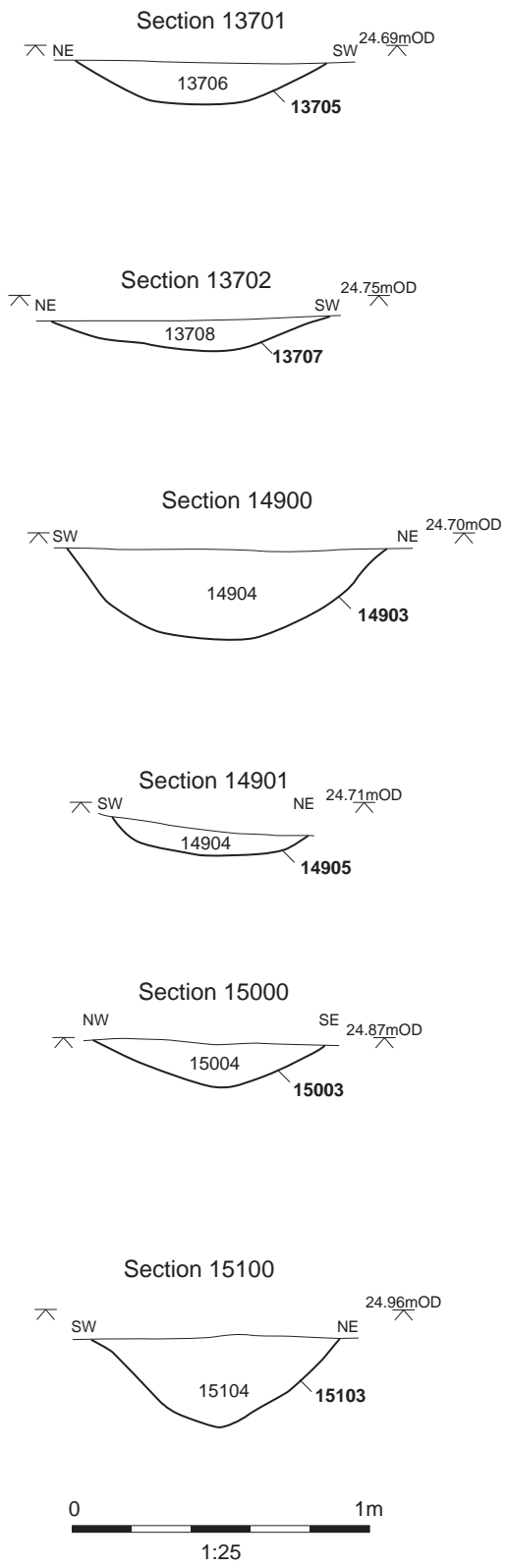

Figure 29: Sections (Trenches 137, 149, 150 and 151)



Plate 1: Ditch 7107, facing south



Plate 2: Ditch 6003, facing south-east



Plate 3: Posthole 7407, facing south



Plate 4: Trench 78, facing north



Plate 5: Ring ditch 7809, facing east



Plate 6: Ditches 7907 and 7909, facing south



Plate 7: Ditch 8003, facing east



Plate 8: Ditch 8106, facing north



Plate 9: Ditch 9305, facing south-east



Plate 10: Pit 9903, facing north-west

COVER SHEET

Title:	Archaeological Evaluation Report for Trial Trenching of Land Parcels 40 and 49, North Ockendon, London Borough of Havering
Project Name:	Lower Thames Crossing Enabling Works
Ref No:	HE540039-BAL-GEN-GEN-REP-HER-00034
Revision No:	P02
Review Date:	04/01/2022
Status:	S2 – For Information
No. of Pages	242

Rev	Date of Issue	Revision Status	Originator	Checker	Approver
P01	29/01/2020	S2	Bikash Rana	Jack Fletcher	Sam Ashton
P02	04/01/2022	S2	Conal Mundy	Jack Fletcher	Emily Erswell



Lower Thames Crossing

Archaeological Evaluation Report for Trial Trenching of
Land Parcels 40 and 49, North Ockendon,
London Borough of Havering

Document Number: HE540039-BAL-GEN-GEN-REP-HER-00034

December 2021



Revision	Production Date	Prepared by	Checked by	Approved for release by	Sections revised
1.0	21st January 2021	Charlotte Howsam, PX Project Officer, Oxford Archaeology	Chris Hayden, Senior Project Manager, Oxford Archaeology	Internal review only	
1.1	29th January 2021	Charlotte Howsam, PX Project Officer, Oxford Archaeology	Steve Lawrence, Senior Project Manager, Oxford Archaeology		
2.1	22nd December 2021	Charlotte Howsam and Steve Teague, PX Project Officers, Oxford Archaeology	Tim Allen. Senior Project Manager, and Steve Lawrence Senior Project Manager, Oxford Archaeology		1.1.4-5 4.11-4.25 5 Appendices A, B, C, D and F

This Evaluation Report has been prepared for Highways England in accordance with the terms and conditions of appointment stated in the Lower Thames Crossing (LTC) Technical Partner Contract. LTC cannot accept any responsibility for any use of or reliance on the contents of this document by any third party.

Contents

Section	Page
Summary	8
Acknowledgements	9
1 Introduction	10
1.1 Project details and scope of work	10
1.2 Location, topography and geology	11
1.3 Previous investigations	11
1.4 Archaeological and historical background.....	12
2 Project Aims	16
2.1 General aims	16
2.2 Specific objectives	17
3 Methodology	19
3.1 Constraints.....	19
3.2 Methodology for the evaluation.....	19
4 Results	21
4.1 Introduction and presentation of results	21
4.2 General soils and ground conditions.....	21
4.3 General distribution of archaeological deposits	21
4.4 Trenches 13-20 (Figs 3 and 5).....	21
4.5 Trenches 21-3 and 53 (Figs 4 and 5).....	25
4.6 Trenches 6, 24, 27-32, 34 and 44 (Figs 6 and 7).....	25
4.7 Trenches 12, 33, 39, 47, 54, 114, 127 and 128 (Figs 8 and 9)	27
4.8 Trenches 58-9, 66, 68, 76 and 78-9 (Figs 10 and 13).....	30
4.9 Trenches 84, 89-90, 97-8 and 100 (Figs 11 and 13).....	31
4.10 Trenches 88, 102-3, 105-6, 112, 117-18 and 120 (Figs 12 and 13)....	32
4.11 Trenches 131 and 133-6 (Figs 14 and 16).....	34
4.12 Trenches 137-8 (Figs 15 and 16).....	36
4.13 Trenches 150-2 (Figs 17 and 20).....	36
4.14 Trenches 155-6 and 158-9 (Figs 18 and 20).....	37
4.15 Trenches 161, 163 and 166 (Figs 19 and 20)	37
4.16 Trenches 185-8 (Figs 21 and 23).....	38
4.17 Trenches 190-1, 193, and 196 (Figs 22 and 23).....	39
4.18 Trenches 176, 180 and 183-4 (Figs 24 and 25).....	39
4.19 Trench 199-204 (Figs 26 and 27)	40
4.20 Trenches 205-14 (Figs 28 and 29).....	42
4.21 Trenches 216-22 (Figs 30 and 31).....	44
4.22 Undated features (Fig. 2)	47
4.23 Geoarchaeological assessment (Fig. 33).....	47
4.24 Finds summary	48
4.25 Environmental summary	49
5 Discussion	50
5.1 Reliability of field investigation	50
5.2 Interpretation.....	50

5.3	Evaluation objectives and results.....	54
Appendix A	Trench Tables	57
Appendix B	Finds Reports	148
Appendix C	Environmental Reports	179
Appendix D	References	191
Appendix E	Abbreviations and Glossary	196
Appendix F	Site Summary.....	197

Figures

Figure 1: Site location

Figure 2: Plan of trench layout

Figure 3: Plan of Trenches 13-20

Figure 4: Plan of Trenches 21-23 and 53

Figure 5: Sections (Trenches 15, 17, 19, 20, 21 and 23)

Figure 6: Plan of Trenches 6, 24, 27-32, 34 and 44

Figure 7: Sections (Trenches 24, 27 and 28)

Figure 8: Plan of Trenches 12, 33, 39, 47, 54, 114, 127 and 128

Figure 9: Sections (Trenches 12, 33 and 114)

Figure 10: Plan of Trenches 58, 59, 66, 68, 76, 78 and 79

Figure 11: Plan of Trenches 84, 89, 90, 97, 98 and 100

Figure 12: Plan of Trenches 88, 102, 103, 105, 106, 112, 117, 118 and 120

Figure 13: Sections (Trenches 66, 78, 88, 97, 100 and 112)

Figure 14: Plan of Trenches 131 and 133-6

Figure 15: Plan of Trenches 137 and 138

Figure 16: Sections (Trenches 131, 133, 135, 137 and 138)

Figure 17: Plan of Trenches 150-52

Figure 18: Plan of Trenches 155, 156, 158-9

Figure 19: Plan of Trenches 161, 163 and 166

Figure 20: Sections (Trenches 150, 151, 156, 159, 161 and 163)

Figure 21: Plan of Trenches 185, 186, 187 and 188

Figure 22: Plan of Trenches 190, 191, 193, and 196

Figure 23: Sections (Trenches 185, 193 and 196)

Figure 24: Plan of Trenches 176, 180, 183 and 184

Figure 25: Sections (Trenches 183 and 184)

Figure 26: Plan of Trenches 199-204

Figure 27: Sections (Trenches 200, 201, 203 and 204)

Figure 28: Plan of Trenches 205-214

Figure 29: Sections (Trenches 206, 208, 210, 212 and 214)

Figure 30: Plan of Trenches 216-222

Figure 31: Sections (Trenches 216, 217, 218, 219 and 220)

Figure 32: Ordnance Survey (1897)

Figure 33: Results of geoarchaeological investigation

Plates

Plate 1: Trench 13, looking north-west

Plate 2: Ditch 1602, looking south

Plate 3: Pit 2302, looking west

Plate 4: Pit 2702/2718, looking north

Plate 5: Pit 3204, looking north

Plate 6: Pit 11403 and ditch 11405, looking west

Plate 7: Pit 4702, looking south-east

Plate 8: Pit 6603 containing a middle Bronze Age vessel (6610=SF 2)

Plate 9: Working shot of inverted urn excavation (SF 1) from pit 9704

Plate 10: Postholes 9702 and 9703, looking south

Plate 11: Ditch 10604, looking north

Plate 12: Ditch 11802, looking north

Plate 13: Ditch 13311, looking south-west

Plate 14: Ditch 18411, looking south-east

Plate 15: Tree-throw 20304, looking south-west

Plate 16: Ditch 21105, looking south

Plate 17: Ditch 21913, looking west

Plate 18: Ditches 22018, 22021 and 22023, looking east

Plate 19: Ditches 22203, 22205 and 22207, looking south

Tables

Table 1: Prehistoric pottery assemblage

Table 2: Roman pottery assemblage

Table 3: Description of post-Roman pottery by context

Table 4: Quantification of flint assemblage

Table 5: Summary of fired clay assemblage

Table 6: Summary of ceramic building material assemblage

Table 7: Description of metalwork by context

Table 8: Description of glass by context

Table 9: Assessment of bulk soil sample flots

Table 10: Animal bone: number of Identified Specimens by period

Table 11: Cattle and horse measurements (mm)

Table 12: Summary of shell assemblage

Table 13: Summary of osteological findings

Summary

Oxford Cotswold Archaeology was commissioned by Balfour Beatty to undertake a trial-trench evaluation of Land Parcels 40 and 49 covered by WSI H of the Lower Thames Crossing Pre-Enabling Works. The land parcels are located west of the village of North Ockendon within the London Borough of Havering and the borough of Thurrock, Essex, centred on NGR 558032 187514. A total of 218 trenches were excavated across two separate phases of fieldwork completed between 22nd September to 6th November 2020 and 19th May to 3rd September 2021.

Of the 218 trenches excavated, 99 trenches were found to contain archaeological remains, largely in low density and comprising ditches, pits, postholes and natural features such as tree-throw holes. Concentrations of features were revealed in the north, north-east and south-east of the site.

A microlith attests to definite Mesolithic activity on the site, and a small assemblage of early Neolithic struck flint, together with two sherds of early-middle Neolithic pottery, in the north-west part of the site, suggest activity here. A tree-throw hole contained an assemblage of flakes and scrapers and a utilised pebble dating to the Beaker/early Bronze Age period, indicating an activity area in the south-east part of the site. Two adjacent pits in the centre of Land Parcel 49, one containing a middle Bronze Age Bucket urn, the other a truncated upright vessel, indicate purposeful placed deposits. These were cut into a curving ditch. A pit containing late Bronze Age pottery was found at the south end of the site, and a ditch in the north-east corner of the site may also be of this date. A possible focus of early Iron Age activity was found either side of the railway line in the western part of Land Parcel 49, including a pit containing a near-complete vessel, and another possible focus that included middle Iron Age pottery at the south end of the site.

Evidence of Roman land use is restricted to small quantities of pottery and ceramic building material, most of which was residual in later features. The small assemblage is suggestive of background activity within the landscape, which may have been related to nearby settlement activity recorded at Manor Farm.

A few sherds of early/mid-Anglo-Saxon pottery indicate a background presence during that period. Activity increased during the medieval period, particularly c 1000-1400. A small number of ditches and pits were perhaps related to agricultural activity, with the pottery assemblages and charred grain indicative of nearby settlements. Medieval remains were concentrated in the west, north and south-east fringes of the site, the first suggesting a focus of activity located along the medieval precursor of Pike Lane adjacent to the site, which may potentially date from the late Saxon period. The last was sited adjacent to activity of 10th-12th century date revealed during earlier excavations during the widening of the M25. The activity to the north dates to later within the medieval period. An assemblage of medieval/post-medieval roof tile and brick also recovered from the northern and south-east areas may indicate that Tudor buildings were located nearby.

Late post-medieval/modern remains were revealed across the site in the form of ditches that correspond with field boundaries depicted on historic Ordnance Survey mapping and residual finds in overburden deposits. These remains are demonstrative of agricultural use of the landscape during this period.

Acknowledgements

Oxford Cotswold Archaeology would like to thank the client, Balfour Beatty, for commissioning this project and managing the site safety and attendances. Thanks are also extended to Adam Single of the Greater London Archaeological Advisory Service, advising the London Borough of Havering, for monitoring and providing advice throughout the project.

The project was managed for Oxford Cotswold Archaeology by Steve Lawrence. The fieldwork was directed by Mark Dodd, who was supported by Ben Slader, Charlotte Brown, Bethany Hardcastle, Adam Single, Alessandra Rossi, Alex Capon, Alex Foley, Anna Lound, Ben Camp, Benjamin Camp, Benjamin Slader, Bethan Morgan, Bevan Cope, Charlotte Brunt, Chris Brown, Chris Griffiths, Ciar Gifford, Daniel Firth, Danika Beale, Ed Cole, Elidh Barr, Ellie Brown, Elodie Powell, Eric Jamieson, George Gurney, Heloise Meziani, Holly Owen, Jack Easen, Jack Heathcote, Jacopo Gelmi, Jason Stewart, Jessica Domiczew, Joao Heitor, Josie Francis, Katherine Whitehouse, Kerree Kendall, Lily Andrews, Mar Roige, Marionna-sandin Catacora, Martha Carruthers, Max Jacobs, Megan Mangum, Melanie Harvell, Mia Long, Molly Vowles, Nat Pacholek, Nathan Griggs, Nicholas Cox, Owen Lazzari, Richard Spencer, Stephanie Matthews, Stephen Foster, Tamara Hadnagyev, Tanja Peter ext, Tara Schug, Timothy Sperring, Tom Bruce, Tom Collie, Tomasz Neyman and Vicky Green. Site survey was undertaken by Caroline Souday and Rachel Alexander, and digitising was carried out by Marjaana Kohtamaki and Caroline Souday. Thanks are also extended to the teams of OA staff that cleaned and packaged the finds under the management of Leigh Allen and Geraldine Crann, processed the environmental remains under the management of Rebecca Nicholson, and prepared the archive under the management of Nicola Scott. The figures and plates were prepared by Benjamin Brown and Charles Rousseaux.

1 Introduction

1.1 Project details and scope of work

- 1.1.1 The Lower Thames Crossing (LTC) Project is located between the A2 in Kent and the M25 in the London Borough of Havering. It will run underneath the River Thames through a tunnel and emerge on the northern side of the river at East Tilbury. From the north portal the road will run to the M25 at Junction 29 via the A13 and pass between North and South Ockendon. The development of the project is managed by LTC, a partnership between Highways England and a consultancy joint venture set up to oversee the scheme.
- 1.1.2 A programme of archaeological trial trenching commenced in the Essex part of the scheme in November 2019. A scheme-wide specification for trial trenching was written by LTC (Highways England 2018), and in July 2019, LTC commissioned Balfour Beatty to deliver the pre-Enabling Works. Balfour Beatty appointed Oxford Archaeology (OA) to prepare a project-wide written scheme of investigation (WSI) for the scheme, which (at the request of the key archaeological stakeholders) is divided into two parts, one for the Kent section and another for Essex and Havering (Oxford Archaeology 2019a; 2019b).
- 1.1.3 Following completion of the project-wide WSIs, OA was instructed to prepare a series of site-specific or group-site specific WSIs for approval by the key archaeological stakeholders in advance of trial trenching to inform the Development Consent Order (DCO). A detailed WSI was created for Land Parcels 40 and 49-52 prior to the trial trenching (WSI H, Oxford Archaeology 2020), which details the archaeological background and potential within the site. It also set out the archaeological aims and objectives appropriate to the investigation of this land parcel by trenching and described the methodology to be applied. The WSI was approved by Adam Single, Archaeology Advisor for Greater London Archaeological Advisory Service (GLAAS), prior to the start of the fieldwork.
- 1.1.4 Oxford Cotswold Archaeology was commissioned as Balfour Beatty's archaeological contractor to undertake the evaluation in accordance with the approved WSI and local and national planning policies. Only Land Parcels 40 and 49 were accessible and available for archaeological evaluation within the scope of WSI H.
- 1.1.5 The fieldwork in the eastern part of Parcel 49 took place between 22nd September and 6th November 2020. Trenching in the remaining western part of Parcel 49 and throughout Parcel 40 was carried out between 19th May and 3rd September 2021. All work followed the MoRPHE Project Manager's guide (Historic England 2015) and the Code of Conduct of the Chartered Institute for Archaeologists (CIfA 2014a). The archaeological works adhered to the standards and guidance for archaeological evaluation, excavation, and archiving (CIfA 2014b; CIFA 2014c).
- 1.1.6 The work was monitored by Adam Single of GLAAS on behalf of the London Borough of Havering.

1.2 Location, topography and geology

- 1.2.1 Land Parcels 40 and 49 (hereafter referred to as ‘the site’) are located to the west of the village of North Ockendon and largely within the London Borough of Havering, though the extreme southern tip of Land Parcel 40 crosses into the Essex borough of Thurrock (Fig. 1). The land parcels are located to the north and south of the junction between the M25 and the London, Tilbury and Southend railway, bounded by Thames Chase on the north and Dennises Lane on the south (NGR 558309 184574; NGR 558153 185456). Land Parcel 49 lies west of the M25, mostly between the M25 and the railway, but a small part extends west of the railway and is bounded by Pike Lane. It ends at the Ockendon Road on the south. Land Parcel 40 lies south of the B1421 Ockendon Road and is bounded on the west by Pea Lane, straddling the railway on the north and the M25 further south, where it ends at the line of the railway on the east.
- 1.2.2 The site is situated on the western slopes of a gravel plateau that is surrounded by the Mar Dyke valley on the north, east and south. At its eastern extent, the site lies at c 24m aOD and falls to c 18m aOD to the west. The ground is also lower-lying to the west, presumably due to the presence of another Pleistocene channel course. A tributary of the Mar Dyke River starts within this channel at Hobbs Hole, a pond located at the north edge of Parcel 49, crosses the Thames Chase Forest Centre just north of the site, and joins the main Mar Dyke river 2.6km to the north-east. A branch of the River Ingrebourne rises not far south of Hobbs Hole and runs north-west, then west and south-west to join the main river 4km away. A third stream rises just 1km south of the site and runs south-west towards the Thames.
- 1.2.3 The British Geological Survey (BGS) has recorded the underlying bedrock geology of the site as clay, silt, and sand of the London Clay Formation (BGS 2020). The bedrock is overlain by a mixture of Boyn Hill sand and gravel and Head deposits of clay, silt, sand, and gravel. The Head clay deposits appears to be located on the slopes and perhaps dry valleys of the North Ockendon plateau.
- 1.2.4 The site was largely under arable cultivation at the time of the fieldwork. Within the surrounding landscape, land use is a mixture of agricultural land and rural development associated with North Ockendon. The M25 and the London, Tilbury and Southend Railway have both altered the rural character of this area and have displaced the historical field boundaries and road network. Directly north of the site is the Thames Chase Forest Centre, which provides leisure activities and community events.

1.3 Previous investigations

- 1.3.1 No known below-ground archaeological investigations have been undertaken within Land Parcel 49, though several investigations have been completed within the vicinity as part of the M25 widening scheme between 2008 and 2011 and includes a small area located immediately adjacent to Land Parcel 40.

- 1.3.2 From north to south this includes the Pond 1791 and Strip Widening (M25023.11), the Ockendon Cutting Palaeolithic watching brief (M25026.11) and the Pond 1812 and Strip Widening (M25025.11). The Pond 1812 and Strip Widening was located within the western part of Land Parcel 40 (Biddulph and Brady 2015). In addition, MOLA undertook an extensive excavation at Manor Farm directly west of the site in 1983-4. This excavation recorded Mesolithic and Neolithic flints, late Bronze Age and Iron Age features, Roman rectilinear enclosures, Saxon ditches, and post-medieval finds. Another excavation carried out by the Passmore Edwards Museum in 1983 at Great Sunnings Farm, 0.9km west of the site, found an Iron Age farmstead or settlement and several cremation burials (MOLA 2011). Several archaeological watching briefs have also been undertaken c 100m east of the site in the area of the former medieval manor and post-medieval manor of North Ockendon Hall.

1.4 Archaeological and historical background

- 1.4.1 The chronological summary of known archaeology given below is taken from the detailed WSI for Land Parcels 40 and 49-52 (Oxford Archaeology 2020) and summarises the most pertinent information related to Land Parcel 49, whilst still giving an overview of the archaeological background of the surrounding landscape.
- 1.4.2 **Palaeolithic.** No Palaeolithic finds have been recorded within the site or within a 1km radius of the site.
- 1.4.3 **Mesolithic and Neolithic.** No known Mesolithic or Neolithic finds have been recorded within the site. During the excavations at Manor Farm in 1983-4, several worked flints were found dating to the Mesolithic and Neolithic, but no features were identified dating to these periods (MOLA 2011). Several struck flints of Mesolithic and late Neolithic or early Bronze Age date were also recovered from an area alongside the M25 just under 1km to the south-west (Biddulph and Brady 2015).
- 1.4.4 **Early Bronze Age.** Whilst no known remains of this date have been recorded within the site, six pits containing late Neolithic/early Bronze Age flints were recorded 1km south-west of the site during the M25 widening excavation (Biddulph and Brady 2015).
- 1.4.5 The cropmarks of several ring ditches have been identified within the 1km study area. It is possible that these features represent ploughed out round barrows of the early Bronze Age period, although small ring ditches such as these are more commonly burial sites of later Bronze Age date or Bronze or Iron Age roundhouse enclosures.
- 1.4.6 **Later Bronze Age and Iron Age.** No recorded remains of later Bronze Age or Iron Age date have previously been recorded within the site boundary.
- 1.4.7 A single pit containing a middle Bronze Age jar was recorded to the south of the site within the western part of Land Parcel 40 during the M25 widening excavation. This was initially thought to have been a cremation burial, but no human bone was identified (Biddulph and Brady 2015). A cremation burial dating from the middle Bronze Age to early Iron Age, however, was recorded 0.8km north of the site during the same phase of works (Biddulph and Brady 2015).

- 1.4.8 A ring ditch possibly representing a late Bronze Age or Iron Age roundhouse along with an associated pit was recorded during the MOLA excavation at Manor Farm, 0.2km south-west of the site. The pottery assemblage mostly dated to the early to middle Iron Age, with a small amount of late Bronze Age pottery also recovered (MOLA 2011).
- 1.4.9 The remains of an Iron Age settlement were recorded by excavation c900m west of the site in 1983 by the Passmore Edwards Museum at Great Sunnings Farm. This excavation identified a series of drainage ditches and gullies along with several large defensive ditches. Five wells were also recorded along with several early Iron Age cremation burials.
- 1.4.10 **Roman period.** No remains suggestive of Roman activity have been recorded within the site, though Roman pottery was found to the south of the site within the western part of Land Parcel 40, just east of Dennises Farm.
- 1.4.11 Two areas of Roman activity were recorded at Manor Farm by the MOLA excavation in 1983-4 to the south-west of the site. A rectangular enclosure containing evidence of 2nd- and 3rd-century activity were cut by three large ditches containing 3rd- to 4th-century occupation material. Recorded further to the south-west were several E-W aligned ditches and a N-S aligned Roman ditch that truncated the possible Iron Age roundhouse, together with five cremation burials, two pits of early Roman date, and features containing slag and burnt clay, suggestive of nearby industrial activity (MOLA 2011). Residual Roman pottery was also found nearby during the excavation of the Tudor foundations of the manor house at Stubbers.
- 1.4.12 Evidence of further Roman activity in the form of pits and latrines dating to the 1st century AD was recorded at Little Belhus Farm located 1.8km south of the site. Roman finds were also recorded at Broadfields Farm located 0.4km north of the site.
- 1.4.13 **Medieval period.** Evidence of Saxon activity was identified 0.2km south-west of site during the excavation at Manor Farm. This excavation found two ditches containing early Saxon pottery (AD 400-750), though it was unclear if this material was residual (MOLA 2011).
- 1.4.14 During the late Saxon period, the area of the site was very likely part of the manorial estate of North and South Ockendon. The Domesday survey notes that North and South Ockendon was very large for the period, with 90 households within four manors. The settlement of Cranham, located c 1km north-west of the site had 29 households within two manors (Palmer 2019). The majority of the site and the surrounding area became part of the later medieval parish of North Ockendon, although the northern part of Land Parcel 49 was located in the parish of Cranham.
- 1.4.15 The roads within the vicinity of the site appear to have had roughly N-S and E-W alignments, and this could relate to the formation of the parishes or the use of more ancient droveways. The major areas of settlement in the vicinity of the site in the later medieval period may have been along the B1421 Ockendon Road, the N-S aligned Pike Lane, and the curving Pea Lane, which continued as a green lane leading to the later medieval

settlement located around North Ockendon Hall. Within the vicinity of the site, later medieval activity has also been recorded at Cranham Hall, within Broadfields Farm and at Stubbers Farm, suggesting that these settlements may have originated in the later medieval period.

- 1.4.16 A later medieval manor and settlement is likely to have been located 300m south-east of the site in the area of the post-medieval North Ockendon Hall and the nearby 12th-century Grade I listed Church of Mary Magdalene. An archaeological watching brief in this area in 1997 exposed timber remains of the possible medieval manor house. An extant T-shaped moat located to the south of the church may have been associated with the medieval manor house. This timber structure and nearby moat may have been the site of the medieval manor of Ockendon Setfountayns, which was formed in the early 13th century. The timber hall was replaced by a red brick building known as North Ockenden Hall in the 16th century (Powell 1978, 110-17).
- 1.4.17 Linear ditches and possible enclosures dating to the 10th-12th centuries, together with pits and postholes suggestive of associated activity, were found to the south of the site within the western part of Land Parcel 40 during the M25 widening excavations (Biddulph and Brady 2015, 26-7). This rural activity was located just south of a green lane (1810) leading from Pea Lane to the settlement around North Ockendon Hall. The green lane is located within the northern end of Land Parcel 40 and is shown on later 19th and early 20th century OS maps. The features recorded in the area of excavation were aligned NW-SE and NE-SW and they contained 70 sherds of pottery dating to the 10th-12th centuries. Pits and post-holes were also recorded amongst the ditches.
- 1.4.18 **Post-medieval to modern periods.** Aside from the construction of the London, Tilbury and Southend Railway in 1892 and the M25, which both bisect this part of the scheme, this area retained a largely rural character in the post-medieval to modern period, with dispersed settlements along key roads.
- 1.4.19 A number of post-medieval buildings were located in the area of the former North Ockendon Hall, including the 18th-century rectory. Within the vicinity of the site, post-medieval farmsteads and buildings are located at Kemps, Broadfields, Stubbers and Cranham Hall. Post-medieval houses are also located along the B1421 Ockendon Road and Church Lane just north-east of the former North Ockendon Hall.
- 1.4.20 Several archaeological watching briefs have been undertaken south-east of the site in the area of the former North Ockendon Hall. Post-medieval remains of the manor and outbuildings have been found along with a well and a wall. North Ockenden Hall was damaged in the Second World War by bombing and was later demolished in the 1960s (Powell 1978, 110-17).
- 1.4.21 Historic mapping demonstrates the largely agricultural nature of the landscape, which was scattered with farmsteads. The associated land was utilised for both arable and pastoral purposes. The tithe map for North Ockendon (c 1841; D/CT 260) indicates that the southern part of the site was in arable use and was owned by Richard Benyon. The northern part of the site was located in the parish of Cranham (as shown on the Cranham Tithe Map of 1841; D/CT 107), though it was also owned by Richard Benyon

and was a mixture of arable and pastoral land. The field boundaries that were identified by the aerial survey within Land Parcels 40, 49 and 51 are shown on the 1841 tithe maps and are therefore likely to be later post-medieval in date.

- 1.4.22 A pre-19th-century brick kiln may have been situated in a field to the south-east of the site and south of the green lane. This is shown on an estate map of dating to 1775 as 'Brick Kiln Field' (D/DBe P4). By the mid-19th century, the tithe map indicates that this field had reverted to arable use. It is possible that a number of clay and sand extraction pits were located close to the brick kiln and may extend into Land Parcel 40.
- 1.4.23 **Undated features and cropmarks.** Aside from the linear features within the site and to the south-east within Land Parcel 51, which are probably of post-medieval date, there are also a number of undated cropmarks that are located in close proximity to the site and may represent later Bronze Age and Iron Age settlement activity. This includes the ring ditches mentioned above that may represent Bronze Age burial monuments or Bronze Age/Iron Age roundhouse enclosures. Several other cropmark features were recorded including possible prehistoric field systems, a ditch, a trackway and an enclosure. Another set of cropmarks representing possible enclosures have been identified in the vicinity of Land Parcel 40.
- 1.4.24 Several cropmarks suggestive of later medieval or early post-medieval field boundaries to the south-east of the site (Aerial Mapping Report site 5B) extend southwards from Hall Farm and may be associated with a medieval settlement at North Ockendon.

2 Project Aims

2.1 General aims

- 2.1.1 The general aims of the project, as stated in the detailed WSI (Oxford Archaeology 2020), were as follows:
- i. To establish the presence or absence of archaeological remains along the line of the scheme, and the extent of any areas where remains appear likely to be absent;
 - ii. In areas where archaeological remains are known or suspected, to clarify the reliability of the cropmark or geophysical survey evidence;
 - iii. In areas where no archaeological remains are indicated by aerial or geophysical survey, to clarify whether this apparent absence of remains is genuine;
 - iv. To determine the degree of complexity of any surviving horizontal or vertical stratigraphy and, in particular, to investigate areas where topography indicates the likelihood of deep deposit sequences for evidence of buried archaeological horizons and palaeoenvironmental sequences;
 - v. Where remains are present, to determine the period(s) represented, the extent, state of preservation and character of the archaeological remains;
 - vi. To establish the range and state of preservation of archaeological artefacts and, through their recovery and examination, to establish the potential for information about the economy, status, and contacts of past inhabitants of the scheme footprint;
 - vii. To determine whether palaeoenvironmental remains are preserved and, where these are found, to determine their types (eg charred plant remains, waterlogged remains, molluscan remains), state of preservation, and potential for environmental information. This will be achieved through the recovery of samples from sedimentary sequences and archaeological features suitable for assessment of a range of palaeoenvironmental remains (eg charred and waterlogged plant remains, charcoal, insects, pollen, diatoms, ostracods/foraminifera and molluscs) and scientific dating (eg radiocarbon and OSL dating);
 - viii. To investigate and record the extent, character and chronology of the sedimentary sequences, in particular those immediately adjacent to and in floodplains, contained within palaeochannels or in dry valleys, and to use the data to refine existing geoarchaeological (predictive) deposit models.
 - ix. To place any identified archaeological remains into their local and, where appropriate, regional or national context, and to assess the implications of any such discoveries for our current understanding of settlement and landscape change in the area, including an assessment of the associations of any remains with reference to the historic landscape;
 - x. To provide sufficient information to enable the LTC archaeological advisor, in consultation with the Key Archaeological Stakeholders, to determine the significance of the archaeological assets identified within the land parcel;

- xi. To provide a report upon the discoveries to inform the Environmental Statement (ES) supporting the Development Consent Order (DCO), and support the preparation of a further archaeological mitigation strategy for the Enabling Works and Construction phases of the scheme; and
- xii. Following the DCO, to deposit the report in the public domain, and to generate an accessible and useable archive which will allow future research of the evidence to be undertaken.

2.2 Specific objectives

2.2.1 The specific project objectives, identified within the detailed WSI (Oxford Archaeology 2020), were as follows:

- xiii. To conduct the programme of archaeological investigation within the general research parameters and objectives defined by the revised East of England Research Framework (Medlycott 2011), and to take account of the aims and objectives of the Greater Thames Estuary Historic Environment Research Framework (Essex County Council, Historic Environment Branch 2010);
- xiv. To clarify through targeting of apparently blank areas whether the cropmarks provide an accurate representation of the range, quantity and types of archaeological features present within the parcel;
- xv. To clarify whether remains of Mesolithic or early Neolithic date exist within the site and, if so, what the relationship of these remains is to the watercourses, and particularly the springs, within and immediately adjacent to the scheme area;
- xvi. To clarify whether remains of later Neolithic and early Bronze Age date exist within the site and, if so, to establish their character and relationship to the watercourses within and adjacent to the site, and to any remains of the earlier Neolithic period;
- xvii. To clarify whether further activity of the later Bronze Age and Iron Age took place within the site and, if so, to establish its character, date and duration using both artefactual and scientific dating. To investigate the relationship of any remains of these periods to the watercourses and particularly the springs immediately adjacent to the site;
- xviii. To establish the extent and character of Roman activity within the site and, in particular, whether the Roman settlement identified at Manor Farm just to the west extends into the site;
- xix. To establish whether further evidence of early Saxon or late Saxon activity exists within the site, and, if so, establish its character, date and duration;
- xx. To establish the date of the possible medieval or post-medieval field boundaries that have been identified within the land parcels making up this site;
- xxi. To look for evidence of medieval and post-medieval farmsteads that may have been located along the roadways adjacent to these land parcels;
- xxii. To look for evidence of the medieval origins of the scattered farmsteads and hamlets of the post-medieval period across the site; and

- xxiii. To look for any evidence of industrial activity within Land Parcels 40 and 41 of the site dating to the later medieval or the post-medieval period and, in particular, investigate if anything remains of the brick-making site.

3 Methodology

3.1 Constraints

- 3.1.1 Only Land Parcels 40 and 49 were accessible and available for archaeological investigation at the time of fieldwork.
- 3.1.2 Several constraints limited the area of the site available for trial trenching. Four high voltage overhead cables crossed Land Parcels 40 and 49 on NNE-SSW and ENE-WSW alignments. A further high voltage overhead cables ran outside the eastern edge of Land Parcel 40 on a N-S alignment. Three ecological constraints also partially extended into the north of the site.
- 3.1.3 These limitations were considered when designing the detailed trench layout of the site, with suitable exclusion zones applied for the overhead cables and ecological constraints. The plotted positions of buried services, however, are often only approximate, and due to this and to low-hanging overhead cables, it was necessary to slightly adjust the locations or size of thirty one trenches (33, 39, 70, 80, 95, 101, 102, 107, 108, 122, 146, 149, 150, 156, 168, 169, 177, 199-201, 203, 205, 207, 208, 211, 214, 215, 217, 218, 221 and 222) in the field. In addition, Trenches 124 and 126 were moved to avoid a trackway, and Trench 115 to avoid blocking access to the site compound. Trenches 114, 127 and 128 could not be excavated in their proposed position due to the location of the site compound and so were moved to the north of the site to further investigate the continuations of archaeological features already revealed in this area. Similarly, Trenches 142 and 143 were moved to the southern end of Land Parcel 40a in order to investigate a concentration of archaeological features in this area. The locations of Trenches 197 and 198 were adjusted to avoid a compound within Land Parcel 40b. Furthermore, Trenches 129, 140 and 141 could not be excavated as they were positioned within site compounds. The approximate locations of these trenches are shown by their numbers in Figure 2.

3.2 Methodology for the evaluation

- 3.2.1 The total land parcel area (40 and 49) was c 36.9ha, and the area available for investigation excluding areas of services, hedgerows and other constraints was c 32ha. A total of 218 trenches were excavated, with 209 trenches measuring 30m long x 2m wide. Trenches 23, 28, 33, 39, 80, 95 and 127 were all shortened to avoid on-site constraints: Trench 33 was reduced to 23m long, Trench 23 to 24m, Trenches 39, 95 and 169 to 25m, Trench 127 to 26m, and Trenches 28, 80 and 168 to 28m. Combined, these represent a c 4.1% sample of the area available for trenching. The location of the trenches is shown on Figure 2.
- 3.2.2 No cropmark features had been identified by the aerial investigation and mapping report of the site (Place Services 2019) and so the trench design layout was devised to provide an even coverage of the land parcel, taking into account the on-site constraints.

- 3.2.3 All trenches were located using a Global Positioning System (GPS) prior to machine excavation. All trenches were excavated using a tracked excavator fitted with a toothless bucket under constant archaeological supervision.
- 3.2.4 Revealed features were hand cleaned and sampled by hand excavation. They were recorded as outlined within the approved WSI (Oxford Archaeology 2020). All finds were bagged by context throughout the evaluation and were recovered for further investigation, and soil samples were collected as appropriate.

4 Results

4.1 Introduction and presentation of results

- 4.1.1 The results of the evaluation are presented below and include a stratigraphic description of the trenches that contained archaeological remains. Trenches that did not contain archaeological features or deposits are not described further below, but the full details of all trenches with dimensions and depths of all deposits can be found in Appendix A. Finds and environmental data are presented in Appendices B and C.
- 4.1.2 Context numbers reflect the trench numbers, unless otherwise stated. For example, ditch 602 is a cut within Trench 6, while pit 11702 is a cut within Trench 117.
- 4.1.3 An overview of the results for the site is shown on Figure 2. Further detailed plans of the trenches that contained archaeological features are shown on Figures 3, 4, 6, 8, 10-12, 14, 15, 17-19, 21-2, 24, 26, 28 and 30 and selected sections are shown on Figures 5, 7, 9, 13, 16, 20, 23, 25, 27, 29 and 31.

4.2 General soils and ground conditions

- 4.2.1 The soil sequence in the trenches was fairly uniform. The natural geology of generally yellowish/orangish brown silty clay was overlain by a greyish brown sandy clay silt ploughsoil, c 0.15-0.58m thick. A greyish/orangish brown sandy silt subsoil, c 0.03-0.40m thick, was identified underlying the ploughsoil and overlying the natural in 86 trenches. Potential colluvial deposits were also recorded in Trench 13 in the north-west of the site.
- 4.2.2 Ground conditions throughout the evaluation were generally good. Archaeological features, where present, were relatively easy to identify against the underlying natural geology.

4.3 General distribution of archaeological deposits

- 4.3.1 Archaeological or potential archaeological features were located in Trenches 1-3, 6, 12-24, 27-34, 39, 44, 47, 53, 54, 58, 59, 63, 66, 68, 76, 78, 79, 84, 88-90, 97, 98, 100, 102, 103, 105, 106, 112, 114, 117, 118, 120, 127, 128, 131, 133-8, 150, 151-2, 155-6, 158-9, 161, 163, 166, 176, 180-8, 190-1, 193, 196, 199-214 and 216-222.
- 4.3.2 The evaluation confirmed the presence of a relatively low density and low complexity of features across the site with a lesser concentration along the southern end of Land Parcel 49 and the northern end of Land Parcel 40. These features comprised ditches, pits, including a possible cremation burial or pyre debris, placed deposits, a pond, postholes, and natural features such as tree-throw holes.

4.4 Trenches 13-20 (Figs 3 and 5)

- 4.4.1 Trenches 13-20 were located within the north-west of Land Parcel 49, surrounding Hobbs Hole. These trenches revealed a series of ditches of differing alignments and a small number of discrete features, including pits and natural features.

- 4.4.2 **Trench 13** revealed a variation in the natural deposits in the west end of the trench, comprising a light blueish grey clayey silt (1302). Upon investigation, two features of modern and probable natural origin appeared to have been cut into a series of layers of potential colluvial/alluvial deposits (Plate 1). Although seen in section only, modern cut 1303 was 1.20m wide and 0.15m deep, with moderately sloping sides and a concave base. It contained a single fill (1304) within which fragments of concrete were observed but not retained. This fill also contained 19 sherds of residual medieval pottery and seven pieces of potentially structural fired clay. This feature truncated a probable natural feature (1308). It measured 1.4m wide and 0.5m deep and had moderately steep sides; its base was not reached due to it exceeding excavation safety regulations. No finds were recovered from its single fill.
- 4.4.3 These features were cut into a mid brownish orange clay silt deposit (1305), c 0.41m thick, which overlaid a mottled light greyish blue silty clay (1306), at least 0.53m thick. Eighteen sherds of late Bronze Age/early Iron Age pottery were retrieved from deposit 1306, and two earlier prehistoric worked flints from deposit 1305.
- 4.4.4 **Trench 14** was located immediately to the west of Trench 13. Ditch 1403 crossed the south of the trench on a NW-SE alignment (with a possible continuation recorded in Trench 20 to the south-east). These features may have been related to a path/trackway shown on historic OS mapping (Fig. 32). The ditch was 1.95m wide and only 0.16m deep, with gently sloping side and a flat, albeit slightly uneven, base. It contained a single fill (1404) from which an iron nail was recovered. An area of modern disturbance in the south-east end of the trench appears to have truncated the ditch.
- 4.4.5 **Trench 15** was positioned c 68m north-west of Trench 14 to the north of Trench 16. Located in the east of the trench was pit 1502, which continued beyond the north trench limit. Its exposed extent measured 1.45m wide and 0.90m deep, and contained two fills (Fig. 5, Section 1500). Lower fill 1503 contained 65 sherds of medieval pottery dating to c 1270-1350 and eight fragments of possibly structural fired clay. Upper fill 1504 contained five pottery sherds of similar medieval date. Bulk soil sample 1, collected from lower fill 1503, produced further fragments of medieval pottery and fired clay, a moderate quantity of charcoal and a small number of charred plant remains, including possible wheat grains.
- 4.4.6 A wide but shallow possible ditch (1507) crossed the centre of the trench on a roughly N-S alignment. Measuring 5.5m wide and 0.2m deep, it had shallow, gently sloping sides imperceptibly breaking into a flat base. Its single fill (1508) contained a sherd of 13th/14th-century pottery and a few pieces of animal bone identified as dog and horse. The ditch may have continued to the SSW into Trenches 16 and 17.
- 4.4.7 Crossing the west end of the trench for c 9m was WNW-ESE aligned ditch 1505, which was 0.59m wide and 0.45m deep, with steep sides and a slightly concave base. Two abraded sherds of broadly middle Bronze Age to Iron Age pottery were recovered from its single fill (1506).
- 4.4.8 **Trench 16** was located immediately to the south of Trench 15. Extending across the length of the trench was ditch 1602, which probably formed a

continuation of the ditch recorded in Trench 17 to the south and possibly Trench 15 to the north. Where excavated, the western part of the ditch had very gently sloping sides for c 0.8m at which point they became steeper, sharply breaking into a flat base with a maximum depth of 0.4m (Plate 2). Its two fills (1603 and 1604) both contained medieval pottery dating to c 1270-1350, and animal bone, including cattle (with evidence of gnawing), pig, and unworked red deer antler. A piece of fired clay was also collected from fill 1604. Further fragments of similarly dated medieval pottery were retrieved from ploughsoil deposit 1600.

- 4.4.9 **Trench 17** was lay immediately south of Trench 16 and revealed a small number of features. Ditch 1704, measuring 3.94m wide and 0.48m deep, appears to have been a continuation of the ditch recorded in Trenches 15 and 16 to the north. Its single fill (1705) produced a residual sherd of 11th-/12th-century pottery, together with small amounts of early post-medieval pottery and ceramic building material (CBM), a fragment of a probable post-medieval horseshoe, and animal bone, some of which has evidence of butchery and gnawing. The ditch may have been associated with an unexcavated deposit (1706) with visible modern inclusions immediately to its west.
- 4.4.10 In the east end of the trench were three sub-circular pits (1702, 1711 and 1713), measuring 0.59-0.62m wide and 0.11-0.19m deep. Pit 1702 had near vertical sides and a flat base, whilst pits 1711 and 1713 had similar moderately sloping sides and concave bases (Fig. 5, Section 1703). All contained single fills. A sherd of Iron Age pottery was recovered from pit 1711, whilst a sherd of medieval pottery dating to c 1200-1350 was collected from pit 1713. Pit 1702 was devoid of finds.
- 4.4.11 Situated to the east of pit 1702 was NE-SW aligned ditch 1707, which extended beyond the trench limits, though its continuation was not identified in nearby trenches. It was 2.44m wide, 0.61 deep and contained a sequence of three fills. No finds were recovered from lower fill 1708, though single pieces of butchered cattle bone and medieval/post-medieval CBM were retrieved from fills 1709 and 1710, respectively.
- 4.4.12 **Trench 18** was located to the south of Trench 17. Ditch 1816 crossed the north end of the trench on an E-W alignment. It measured 4.50m wide and 0.44m deep and contained two fills. Small quantities of post-medieval pottery, medieval/post-medieval CBM and post-medieval/modern iron objects, together with a moderate quantity of animal bone (including a notable collection of cattle and horse metapodials, and some with signs of butchery and gnawing), were retrieved from lower fill 1817. The ditch cut an earlier ditch (1814), which was at least 2.8m wide and 0.26m deep, though its base was not reached as its excavation exceeded safety regulations. A few pieces of animal bone, of which some have signs of butchery, and a sherd of post-medieval pottery were retrieved from its excavated fill (1815). These ditches appear to have truncated and largely removed an earlier shallow ditch (1812) on an apparent NW-SE alignment. Ditch 1812 was 0.82m wide and 0.22m deep. No finds were recovered from its single fill. Probable continuations of ditches 1814 and 1816 were

recorded to the east in Trench 19, though the continuation of ditch 1812 was not seen in surrounding trenches.

- 4.4.13 Crossing the centre of the trench was NE-SW aligned ditch 1803, which was 1.12m wide and 0.42m deep. This ditch was recut by shallower ditch 1805. Both had similar profiles and single fills. Small quantities of early post-medieval pottery, CBM, clay tobacco pipe, iron objects (including nails) and animal bones were recovered from fills 1804 and 1809. Unexcavated ditch 1802 was aligned ENE-WSW and had an unclear stratigraphic relationship with ditches 1803 and 1805. An area of probable natural rooting (1811) was also found adjacent to ditch 1803. Three fragments of animal bone and an iron nail were retrieved from this feature.
- 4.4.14 Approximately 7m to the south was shallow ditch 1806, which extended across the trench for c 2.25m on an ENE-WSW alignment. It was 0.66m wide, 0.06m deep and contained a single fill from which no finds were retrieved.
- 4.4.15 A modern land drain (1808) on a NW-SE alignment and an unexcavated curvilinear ditch (1810) were also observed in the trench. No finds were recovered from the surface of ditch 1810.
- 4.4.16 **Trench 19** was positioned immediately to the east of Trench 18 and revealed the continuation of ditches 1814 and 1816 in the north of the trench. Aligned WNW-ESE, ditch 1902 was 1.70m wide and 0.48m deep. Its lower fill (1903) was devoid of finds, though its upper fill (1904) contained two residual sherds of broadly Roman pottery, two pieces of medieval/post-medieval CBM, and a fragment of cattle bone.
- 4.4.17 Ditch 1902 was recut by parallel ditch 1905/1908, which was up to 1.84m wide and 0.78m deep (Fig. 5, Section 1900). It contained a sequence of two fills, which contained early post-medieval pottery and CBM, animal bone and a possible rotary quern stone fragment (recovered from upper fill 1909 of intervention 1908). Two further sherds of similar pottery were recovered from lower fill 1906 of intervention 1905.
- 4.4.18 **Trench 20** was laid to the east of Trench 19 and south of Trench 13. Ditch 2002 crossed the south-west end of the trench on a NW-SE alignment. It measured 1.22m wide and 0.24m deep and had moderately sloping sides and a slightly concave base. No finds were recovered from its single fill, though the ditch may have formed a continuation of ditch 1403 recorded in Trench 14 to the north-west.
- 4.4.19 Located in the north-east of the trench was oval pit 2004, which measured at least 1.18m long, 0.41m wide and 0.06m deep (Fig. 5, Section 2001). Its single fill (2005) contained a piece of animal bone with a butchery mark, a fragment of fired clay, possibly from an oven/hearth, and a piece of medieval/post-medieval CBM. Bulk soil sample 6, collected from fill 2005, contained large quantities of charcoal and unworked burnt flint but no charred plant remains.
- 4.4.20 A natural feature (2006), possibly representing a small tree-throw hole, was also investigated within the trench. No finds were recovered from the feature.

4.5 Trenches 21-3 and 53 (Figs 4 and 5)

- 4.5.1 Trenches 21-23 and 53 were located towards the north-west of Land Parcel 49, and revealed a small number of archaeological features, including a ditch correlating with a field boundary depicted on historic Ordnance Survey (OS) mapping (Fig. 32).
- 4.5.2 **Trench 21** was located c 59m south-west of Trench 20, directly south of Trench 18. Crossing the south-west end of the trench was N-S aligned ditch 2103, measuring 1.20m wide and 0.61m deep (Fig. 5, Section 2100). It contained two fills (2104 and 2105), with a residual sherd of middle Neolithic pottery, seven fragments of medieval/post-medieval CBM, and six sherds of early post-medieval pottery retrieved from upper fill 2105. The ditch was not found to have continued into nearby trenches. A modern land drain on a WNW-ESE alignment was also noted within the trench.
- 4.5.3 **Trench 22** lay immediately to the east of Trench 21 and contained a WNW-ESE aligned ditch (2202) measuring 1.40m wide and 0.46m deep. It contained a sequence of five fills indicative of natural infilling. Two sherds of medieval pottery dating to c 1270-1400, a piece of medieval/post-medieval CBM, and a fragment of animal bone were recovered from uppermost fill 2207, and a shard of mid-20th-century glass was collected from intermediate fill 2204. The position of the ditch closely, but not directly, correlates with that of a field boundary shown on late 19th-century OS mapping (Fig. 32). An eastward continuation of this ditch was recorded in Trench 53.
- 4.5.4 **Trench 23** was positioned to the south-west of Trench 22 and partially revealed a pit (2302) that extended beyond the trench limits. Its exposed extent measured 1.32m wide and 0.51m deep and exhibited moderately sloping sides and an undulating base (Fig. 5, Section 2300; Plate 3). It contained a single fill (2303) from which a sherd of middle to late Roman pottery and a fragment of undated CBM were retrieved.
- 4.5.5 **Trench 53** was located c 63.5m to the east of Trench 22 and revealed the continuation of the late post-medieval field boundary seen in Trench 22. Ditch 5302 measured at least 1.5m wide and 0.54m deep, though its full profile was not exposed within the trench. No finds were recovered from its fill, though its position and correlation with historic mapping indicates its late post-medieval date.

4.6 Trenches 6, 24, 27-32, 34 and 44 (Figs 6 and 7)

- 4.6.1 These trenches were positioned in the north-east of Land Parcel 49 and revealed a number of ditches and pits containing varied dating material.
- 4.6.2 **Trench 6** contained a single ditch (602), which crossed the east end of the trench on an NNE-SSW alignment. Measuring 3.4m wide and 0.78m deep, it contained a sequence of seven fills indicative of natural collapse/erosion and gradual natural infilling. No finds were recovered from any of the fills, though the position of the ditch corresponds with a field boundary depicted on late 19th-century OS mapping (Fig. 32). The continuation of this field boundary ditch was recorded in Trenches 33, 39 and 54 located to the SSW (Figs 6 and 8).

- 4.6.3 **Trench 24** was located to the south-east of Trench 6 and revealed three narrow ditches. Parallel ditches 2403 and 2405 crossed the east end of the trench on a NE-SW alignment, whilst ditch 2407 was on a perpendicular NW-SE alignment to the west of ditch 2403. They measured 0.46-0.68m wide and 0.12-0.14m deep and had similar profiles and single fills (Fig. 7, Section 2401). None of the ditches contained any finds, and they were not seen to have continued into nearby trenches.
- 4.6.4 **Trench 27** was situated c 100m east of Trench 24, adjacent to blank Trench 26. Crossing the centre of the trench, N-S aligned ditch 2714 was 1.30m wide and 0.39m deep. It contained three fills, all of which were devoid of finds (Fig. 7, Section 2702). Its probable southward continuation was recorded in Trench 32, where late Bronze Age/Iron Age pottery was found.
- 4.6.5 The ditch was cut by large pit 2702/2718, which was 7.90m long by at least 1.60m wide and 0.68m deep, extending beyond the trench limits. It contained a sequence of three fills indicative of erosion/slumping of the sides and natural infilling (Fig. 7, Section 2702; Plate 4). A sherd of broadly middle Bronze Age to Iron Age pottery, three of late Bronze Age/Iron Age date and a piece of Roman CBM were recovered from intermediate fill 2704/2720. A residual Mesolithic microlith and a sherd of late Bronze Age/early Iron Age pottery were collected from upper fill 2705.
- 4.6.6 The south-west end of pit 2702/2718 was cut by NNE-SSW aligned plough furrow 2710/2712, adjacent to which were two further parallel furrows (2706 and 2708). They were 0.42-0.47m wide and 0.08-0.34m deep, with similar profiles of moderately sloping sides and slightly concave bases. They all had similar single fills, though only fill 2709 of furrow 2708 contained finds which comprise two residual sherds of early and late Roman pottery.
- 4.6.7 **Trench 32** was located immediately to the south of Trench 27. Ditch 3202 crossed the east end of the trench on a N-S alignment and probably formed a continuation of the ditch recorded in Trench 27 to the north. Measuring 1.50m wide and 0.38m deep, it had moderately sloping sides and a concave base. It contained a single fill (3203) from which six sherds of late Bronze Age/Iron Age pottery were recovered.
- 4.6.8 Approximately 4.6m to the west of the ditch was sub-oval pit 3204, which was 1.45m wide and only 0.12m deep, with moderately steep sides and a flat base (Plate 5). No finds were retrieved from its single fill.
- 4.6.9 **Trench 31** was positioned immediately to the west of Trench 32 and revealed a WNW-ESE aligned ditch (3102). The ditch measured 1.84m wide and 0.44m deep, and had moderately sloping sides and a concave base. It contained a single fill that was devoid of finds. The ditch was not seen to have continued into nearby trenches.
- 4.6.10 **Trench 30** was located to the west of Trench 31 and contained a NNE-SSW aligned ditch (3002). It was 1.08m wide and 0.40m deep, and contained two fills. No finds were recovered from the ditch, though its plotted position closely, but not directly, corresponds with a field boundary depicted on late 19th-century OS mapping (Fig. 32). Continuations of this field boundary ditch were recorded in Trench 59 and 68 further to the south (Fig. 10).

- 4.6.11 **Trench 29** was laid directly to the west of Trench 30. Ditch 2902 crossed the south of the trench on an E-W alignment. Measuring 0.81m wide and 0.27m deep, it had moderately sloping sides and a concave base. It contained a single fill, which was devoid of finds. The ditch was not seen to have continued into nearby trenches.
- 4.6.12 **Trench 28** was positioned to the west of Trench 29 and revealed a single ditch (2802) in the west end of the trench. Aligned N-S, ditch 2802 was 1.58m wide, 0.68m deep and contained two fills (Fig. 7, Section 2800). A sherd of Roman pottery dating to AD 120-200 was retrieved from fill 2803. Continuations of the ditch were not observed in nearby trenches.
- 4.6.13 **Trench 34** was positioned to the south of Trench 28 and revealed a possible pit (3402), measuring 1.12m wide and 0.16m deep, in the south of the trench. The pit was irregular in form with gently sloping and slightly undercut sides and a concave, albeit uneven base, suggesting it may have been natural in origin, perhaps a tree-throw hole. No finds were hand-collected from its mid brownish grey sandy silt fill (3403), though frequent charcoal inclusions were noted. Bulk soil sample 5, collected from fill 3403, produced a moderate quantity of charcoal and a few pieces of unworked burnt flint but no charred plant remains. A very small amount of calcined human bone was also recovered from sample 5. Given the charcoal-rich nature of fill 3403 and the small quantity of bone present, it is possible that the feature (3402) had been used for the deposition of pyre debris rather than for a formal cremation burial.
- 4.6.14 Seven residual sherds of broadly late Bronze Age to Iron Age pottery, a piece of animal bone, and a modern stainless steel nail were recovered from ploughsoil 3400.
- 4.6.15 **Trench 44** was located c 110m to the east of Trench 34, south of blank Trench 37. Ditch 4402 crossed the north end of the trench on a NW-SE alignment, though its continuation was not seen in nearby trenches. It was 1.66m wide, 0.36m deep and had moderately sloping sides and a slightly concave base. It contained a single fill from which no finds were retrieved.

4.7 Trenches 12, 33, 39, 47, 54, 114, 127 and 128 (Figs 8 and 9)

- 4.7.1 This group of trenches was located towards the north-west of Land Parcel 49 and revealed a small number of pits and a series of ditches, including a late post-medieval field boundary recorded across Trenches 33, 39, 47 and 54 (and also Trench 6 to the north, Fig. 6), which corresponds with historic mapping (Fig. 32).
- 4.7.2 **Trench 12** contained a number of ditches and a pit. Ditch 1206, which was 1m wide and 0.16m deep, crossed the west of the trench on a NNW-SSE alignment, though it was not seen to have continued into nearby trenches. No finds were recovered from its single fill. A natural feature (1209), possibly an animal burrow, was investigated immediately to the east of ditch 1206.
- 4.7.3 Also adjacent to ditch 1206, crossing the centre of the trench, was WNW-ESE aligned ditch 1202. The centre of the trench was widened to safely

reveal the full profile of the ditch. The ditch was exposed for a distance of c 9m and was 2.94m wide and 1.16m deep, containing a sequence of five fills (Fig. 9, Section 1201). Small quantities of residual earlier prehistoric worked flint, residual prehistoric pottery (15 sherds) of broadly middle Bronze Age to Iron Age date, two pieces of Roman CBM, and a chip of broadly Roman pottery were recovered from upper fill 1205, together with a few fragments of animal bone and fired clay. Potentially residual earlier prehistoric worked flints were also recovered from intermediate fill 1203 and lower fill 1208. The ditch was not seen to have continued into nearby Trench 127.

- 4.7.4 Located to the east of ditch 1202 were two intercutting features, pit 1212 and ditch 1214, both of which continued beyond the trench limits (Fig. 9, Section 1203). Pit 1212 was 0.96m wide and 0.34m deep, with a single fill (1213) that contained notable charcoal, burnt clay and flint inclusions. Although no finds were hand collected from fill 1213, bulk soil sample 7 yielded a large quantity of charcoal and a few pieces of unworked burnt flint and fired clay but no charred plant remains. Ditch 1214 cut the east side of pit 1212. It was aligned NNW-SSE, though it was not seen to have continued into Trench 114 to the north. Measuring 0.86m wide and 0.35m deep, it contained three fills, all of which were devoid of finds.
- 4.7.5 Approximately 4m to the east of ditch 1214 was parallel ditch 1218. Its NNW continuation was recorded in plan only in Trench 114. The ditch was 1.70m wide, 0.56m deep and contained three fills from which no finds were retrieved. The ditch was truncated by shallow, WNW-ESE aligned ditch 1222 which measured 1.16m wide and only 0.06m deep. No finds were recovered from its single fill.
- 4.7.6 **Trench 114** was repositioned immediately to the north of Trench 12 in order to further investigate the continuations of the ditches revealed in Trench 12. Unexcavated ditch 11407 crossed the south-west end of the trench on a NW-SE alignment and formed the continuation of ditch 1218 recorded to the south. No finds were recovered from the surface of the ditch.
- 4.7.7 Approximately 3.3m to the north-east was the rounded terminal of slightly curved ditch 11405, which extended across the trench for c 9.6m on a broadly NE-SW alignment before continuing beyond the trench limits. It was 0.60m wide and 0.36m deep, and contained a single fill that was devoid of finds.
- 4.7.8 Ditch 11405 cut pit 11403, which measured at least 0.47m wide and 0.43m deep, continuing beyond the trench limits (Fig. 9, Section 11400). The pit contained two fills, with burnt clay inclusions visible in lower fill 11408 and charcoal lenses noted in upper fill 11404 (Plate 6). An earlier prehistoric worked flint flake was retrieved from the latter. Soil sample 8, collected from fill 11404, produced a large quantity of charcoal and a few pieces of unworked burnt flint and indeterminate fired clay but no charred plant remains.
- 4.7.9 The terminal of ditch 11409 cut ditch 11405. It was similarly curved, though on a slightly different orientation. It was 0.4m wide, 0.2m deep and contained a single fill from which no finds were retrieved.

- 4.7.10 A residual small sherd of early-middle Neolithic pottery was recovered from subsoil 11401. A WNW-ESE aligned modern land drain was also revealed within the south-west end of the trench.
- 4.7.11 **Trench 33** was located c 54m to the east of Trenches 12 and 114. A single ditch (3302), which crossed the west end of the trench on a NNE-SSW alignment, was revealed. It was 1.78m wide and 0.64m deep, and contained two fills (Fig. 9, Section 3300). Although no finds were recovered from the ditch, its plotted position corresponds with a field boundary depicted on late 19th-century OS mapping (Fig. 32), with its continuation recorded in Trenches 39, 47 and 54 to the south, and also Trench 6 to the north (Fig. 6).
- 4.7.12 **Trench 39** was positioned to the south-west of Trench 33 and revealed the continuation of the late post-medieval field boundary seen in Trenches 6, 33, 47 and 54, corresponding with historic mapping. Extending beyond the trench limits, ditch 3902 measured at least 1.54m wide and 0.45m deep, though its full profile was not revealed by the trench. Two fills were recorded within the exposed part of the ditch, though no finds were recovered.
- 4.7.13 **Trench 47** lay immediately to the south of Trench 39. Crossing the south of the trench for c 5.8m was NNW-SSE aligned ditch 4704 which was not seen to have extended into nearby trenches. Measuring 1.20m wide and 0.24m deep, it contained a single fill (4705) from which an earlier prehistoric worked flint flake was collected.
- 4.7.14 Adjacent to the ditch was sub-oval pit 4702, which was 0.74m wide and only 0.08m deep, with shallow sides and a slightly concave base. It contained a single fill (4703) that contained charcoal and burnt clay inclusions, though no finds were hand collected (Plate 7). Bulk soil sample 4, collected from the fill, produced a moderate quantity of charred plant remains, including possible wheat and barley grains, and weed seeds, as well as a moderate quantity of charcoal and a few pieces of unworked burnt flint and fired clay, perhaps from an oven/hearth structure.
- 4.7.15 Further to the south was ditch 4706, which just extended into the south end of the trench. Its exposed extent measured 0.38m wide and 0.44m deep, exhibiting moderately sloping sides. No finds were recovered from its two fills, but its position suggests that it formed a continuation of the late post-medieval field boundary ditch seen across Trenches 33, 39 and 54, and also Trench 6, roughly correlating with historic OS maps (Fig. 32).
- 4.7.16 **Trench 54** was located to the south of Trench 47 and revealed the continuation of the late post-medieval field boundary recorded across Trenches 33, 39 and 47, and Trench 6 further to the north. Aligned NNE-SSW, ditch 5402 was 1.40m wide and 0.58m deep, and had a similar profile to ditch 3302. It contained three fills indicative of natural infilling. No finds were recovered from the ditch, though its position, correlating with historic mapping, demonstrates its late post-medieval date (Fig. 32).
- 4.7.17 **Trench 127** was located immediately to the south-west of Trench 33 and east of Trench 39. Situated in the centre of the trench was pit 12703 which measured 0.60m wide and only 0.08m deep, with gently sloping sides and a slightly concave base. Its single fill (12704), with occasional charcoal and

burnt clay inclusions, contained an earlier prehistoric worked flint flake. A modern land drain aligned NNE-SSW was also observed crossing the trench.

- 4.7.18 **Trench 128** was positioned to the south-east of Trench 33. Unexcavated ditch 12804 was recorded in plan crossing the trench for c 18.3m on a NNE-SSW alignment. Part of a fired clay object, potentially a pedestal from briquetage manufacture or from a portable oven, was recovered from its surface.
- 4.7.19 A tree-throw hole (12803) was also exposed in the north end of the trench, from which three sherds of Anglo-Saxon pottery dating to c 400-600 were collected.

4.8 Trenches 58-9, 66, 68, 76 and 78-9 (Figs 10 and 13)

- 4.8.1 These trenches were all located towards east of Land Parcel 49 and revealed ditches relating to late post-medieval field boundaries as seen on historic mapping (Fig. 32) and a small number of other features, notably ditches and a pit containing the truncated remains of a pot.
- 4.8.2 **Trench 58** was positioned c 118m to the east of Trench 54, directly east of blank Trench 57. A shallow narrow ditch (5802) crossed the east of the trench on a NNE-SSW alignment. Measuring 0.46m wide and 0.15m deep, it had moderately sloping sides and a slightly concave base. It contained a single fill from which no finds were recovered. The continuation of the ditch was not revealed in nearby trenches.
- 4.8.3 **Trench 59** was located immediately to the east of Trench 58 and revealed the southward continuation of the late post-medieval field boundary ditch revealed in Trench 30 to the north (Fig. 6); the ditch was also revealed in Trench 68 directly to the south. Ditch 5902 crossed the length of the trench on a broadly N-S alignment and measured 0.64m wide and 0.48m deep. It had moderately steep sides and a flat base, and contained two fills, neither of which produced any finds.
- 4.8.4 **Trench 68** was situated directly to the south of Trench 59. It revealed the southward continuation of the late post-medieval field boundary ditch excavated in Trench 59. Aligned N-S, ditch 6802 was recorded in plan only and measured c 1.8m wide. No finds were recovered from its surface.
- 4.8.5 **Trench 66** was laid to the west of Trench 68, south of blank Trench 57. Shallow ditch 6604 crossed the west end of the trench on a NNW-SSE alignment, though its continuation was not seen in nearby trenches. It was 1.2m wide and only 0.1m deep, with a slightly concave base. It contained a single fill from which no finds were recovered.
- 4.8.6 The west side of ditch 6604 was cut by pit 6603, which measured 0.4m wide and 0.16m deep. Within the pit was the base and lower part of a middle Bronze Age vessel (6610, SF 2) in a mid brownish grey sandy silt fill (6602; Plate 8). No cremated human remains were identified, nor any other finds recovered from the fill suggesting that this was a placed deposit.
- 4.8.7 Adjacent to pit 6603 and ditch 6604 was sub-circular pit 6606. Measuring 0.76m wide and 0.18m deep, it had near vertical sides and a flat base (Fig. 13, Section 6602). It contained a basal fill (6611) suggesting that the pit had

been lined with clay, though there were no indications of burning. This was overlain with a secondary fill (6607) from which 54 sherds of a middle Bronze Age Deverel-Rimbury bucket urn were retrieved.

- 4.8.8 Approximately 2m to the east of ditch 6604 was sub-circular posthole 6608. The posthole was 0.30m wide and 0.18m deep, with near vertical sides and a flat base. No finds were collected from its single fill.
- 4.8.9 **Trench 76** lay immediately south of Trench 66. Ditch 7602, measuring 1.9m wide and 0.5m deep, crossed the north end of the trench on an E-W alignment. Its plotted position is located close to that of a field boundary depicted on late 19th-century OS maps (Fig. 32) and so probably functioned as a land drain relating to agricultural activities.
- 4.8.10 **Trench 78** was located to the east of Trench 76 and immediately south of Trench 68. Large ditch 7802 crossed the centre of the trench on a broadly E-W alignment. Measuring 4.8m wide and at least 0.68m deep, it had moderately sloping, stepped sides; the base of the ditch was not reached, as the depth of the feature exceeded excavation safety regulations (Fig. 13, Section 7800). Three fills were recorded, though only lower fill 7803 contained any finds, comprising a piece of medieval/post-medieval CBM. The plotted position of the ditch is in proximity to the position of a field boundary depicted on a late 19th-century OS map (Fig. 32) and so may have been related.
- 4.8.11 **Trench 79** was positioned to the east of Trench 78 and revealed a probable tree-throw hole (7902) measuring 0.73m wide. No finds were found within the feature.

4.9 Trenches 84, 89-90, 97-8 and 100 (Figs 11 and 13)

- 4.9.1 Trenches 84, 89, 90, 97 and 98 were positioned towards the south-west of Land Parcel 49, within which a small number of ditches, pits and postholes were encountered.
- 4.9.2 **Trench 84** was located c 49m to the south-west of Trench 76 and revealed a single possible posthole (8402). Sub-oval in plan, measuring 0.6m wide and only 0.1m deep, it had a slightly concave base and contained a single fill that was devoid of finds.
- 4.9.3 **Trench 89** was situated c 100m to the south-west of Trench 84, adjacent to the London, Tilbury and Southend Railway line that bisected this part of the site. Two parallel ditches (8902 and 8904), spaced c 16.5m apart, crossed the trench on a N-S alignment. In the west of the trench, ditch 8904 was 1.60m wide and 0.32m deep, with moderately steep sides and a concave, albeit uneven, base. In contrast, ditch 8902 was narrower, measuring 0.32m wide, and was 0.24m deep, with moderately sloping sides and a concave base. Both contained similar single fills, neither of which contained any finds. Continuations of these ditches were not identified within nearby trenches.
- 4.9.4 **Trench 90** was laid immediately to the east of Trench 89 and revealed a 0.35m-wide natural feature (9002), possibly a tree-throw hole, within the south end of the trench. No finds were recovered from this feature.

- 4.9.5 **Trench 97** was positioned to the south-east of Trench 90 and contained three archaeological features. Located in the centre of the trench was pit 9704, which comprised a small sub-circular pit, measuring 0.25m wide and 0.08m deep. Placed within the pit was a small, inverted vessel (SF 1) of late Bronze Age/early Iron Age date. The pit was filled with a dark greyish brown sandy clay fill (9705) with occasional charcoal inclusions. No cremated human remains were identified within the vessel or fill, and no other artefacts were recovered from the feature. It is possible that the vessel indicates a placed deposit. The vessel was block lifted (Plate 9) and subsequently excavated within the laboratory. Bulk soil samples 9-12 were collected, comprising spits of the exterior material and interior fill. All four samples contained small quantities of charcoal, whilst an indeterminate charred plant fragment and a few weed seeds were recovered from samples 10 and 11, respectively. Three further pieces of pottery were collected from samples 11 and 12.
- 4.9.6 Situated in the north of the trench were two adjacent postholes (9702 and 9703). Similar in plan, they measured 0.20-0.22m wide. Only the concave base of posthole 9702, 0.04m deep, survived, while posthole 9703 was 0.14m deep with steep sides and a flat base (Fig. 13, Section 9704; Plate 10). Both contained similar single fills (9706 and 9707 respectively) which were devoid of finds. Bulks soil samples 2 and 3 were collected from the fills of the postholes and yielded small to moderate quantities of charcoal and a small quantity of charred weed seeds.
- 4.9.7 **Trench 98** was located immediately to the east of Trench 97. Aligned N-S, possible ditch 9803 was revealed in the west end of the trench for c 1.6m, ending in a rounded terminal. It continued beyond the northern trench limits, though its northward continuation was not encountered within nearby trenches. Measuring 0.71m wide and 0.52m deep, it had near vertical sides and a concave base. It contained a single fill from which no finds were retrieved.
- 4.9.8 Crossing the east end of the trench on a N-S alignment was ditch 9805. It was 0.51m wide and 0.32m deep, with moderately sloping sides and a concave base. No finds were recovered from its single fill.
- 4.9.9 **Trench 100** was located to the south-west of Trenches 97 and 98. Extending across the trench for a distance of c 16.5m was NW-SE aligned ditch 10002. Measuring 1.40m wide and 0.18m deep, it contained a single fill (10003) from which four sherds of late Bronze Age pottery were recovered (Fig. 13, Section 10000). Possible continuations of this ditch were not seen in nearby trenches.

4.10 Trenches 88, 102-3, 105-6, 112, 117-18 and 120 (Figs 12 and 13)

- 4.10.1 These trenches were positioned in the south-east of Land Parcel 49 and revealed a small number of pits and ditches, including a late post-medieval field boundary ditch across Trenches 88, 102, 106 and 120, which correlates with historic OS maps (Fig. 32).
- 4.10.2 **Trench 88** was located c 162m to the north-east of Trench 98, directly south of Trenches 78 and 79. Two ditches (8802 and 8805) corresponding with

field boundaries depicted on late 19th-century OS mapping were encountered within the trench. Aligned WNW-ESE, ditch 8805 was 2.3m wide and at least 0.7m deep, though its base was not reached because the excavation of the feature exceeded safety regulations. Three fills were recorded within the ditch. No finds were recovered from fills 8806 and 8807. Upper fill 8808 contained finds of clearly modern date, including a plastic bag, though these were not retained given their recent date.

- 4.10.3 Historic OS maps demonstrate that field boundary ditch 8805 joined with a roughly N-S aligned field boundary, recorded as ditch 8802 in the south-west of Trench 88. Measuring 1.60m wide and 0.58m deep, ditch 8802 contained three fills indicative of natural erosion/slumping and infilling (8803, 8804, 8809; Fig. 13, Section 8800), with fragments of medieval/post-medieval and 18th- to 19th-century CBM recovered from fills 8803 and 8804.
- 4.10.4 A natural feature suggestive of a tree-throw hole (8810), measuring 0.4m wide and 0.2m deep, was also investigated within the trench. No finds were found.
- 4.10.5 **Trench 102** was situated to the south of Trench 88 and contained the southward continuation of late post-medieval field boundary ditch 8802; the ditch was also recorded in Trenches 106 and 120 further to the south. Ditch 10202 measured 3.20m wide and 0.63m deep, and had moderately to steeply sloping sides and a flat base. It contained two fills, and eight shards of glass comprising parts of the same bottle were recovered from upper fill 10204.
- 4.10.6 **Trench 103** lay immediately to the east of Trench 102 and revealed two nature features (10302 and 10303) that, upon excavation, appeared to be possible tree-throw holes, neither of which contained any finds.
- 4.10.7 **Trench 105** was positioned immediately south-west of Trench 102 and contained an E-W aligned ditch (10502) that crossed the centre of the trench; nearby trenches did not reveal its potential continuation. Measuring 0.73m wide and 0.19m deep, it had moderately steep sides and a concave base. No finds were retrieved from its single fill.
- 4.10.8 **Trench 106** was located to the east of Trench 105 and south of Trench 102. Crossing the west of the trench was N-S aligned ditch 10604, which constituted a continuation of the late post-medieval field boundary ditch also recorded in Trenches 88, 102 and 120. It was 3.35m wide, 0.74m deep and had a profile similar to that of ditch 10202 recorded to the north (Plate 11). It contained a sequence of three fills. Only upper fill 10605 contained finds which comprise a residual sherd of middle Bronze Age to Iron Age pottery, three sherds of post-medieval pottery, three fragments of medieval/post-medieval CBM, and 13 pieces of animal bone.
- 4.10.9 Situated c 8.8m to the east of ditch 10604 was sub-circular pit 10602. Measuring 0.50m wide, only the slightly concave base of the pit, 0.16m deep, survived. Nevertheless, two sherds of Iron Age pottery were retrieved from its single fill (10603).
- 4.10.10 **Trench 112** was positioned to the south of Trenches 105 and 106. Ditch 11202 crossed the trench on a N-S alignment and measured 1.66m wide

and 0.27m deep. An abraded sherd of middle Neolithic pottery and a possible rotary quern stone fragment were retrieved from its single fill (11203). The ditch was not seen to have continued into nearby trenches.

- 4.10.11 **Trench 117** was located c 68m to the south-west of Trench 112, directly south of blank Trench 110. Located towards the south of the trench was sub-circular pit 11702. Measuring 0.94m wide and only 0.07m deep, it had moderately sloping sides and a flat base. No finds were recovered from its single fill.
- 4.10.12 **Trench 118** was situated immediately to the east of Trench 117. Aligned N-S, ditch 11802 crossed the west end of the trench, though its continuation was not encountered within nearby trenches. The ditch was 1.3m wide and 0.3m deep, with moderately sloping sides and a concave base (Plate 12). No finds were recovered from its single fill.
- 4.10.13 **Trench 120** was located to the east of Trench 118 and contained the southward continuation of the N-S aligned late post-medieval field boundary ditch recorded in Trenches 88, 102 and 106 to the north, which corresponds with historic mapping (Fig. 32). Measuring 1.60m wide and 0.48m deep, ditch 12002 was similar in size and form to ditch 8802 recorded in Trench 88. It also contained a sequence of three fills (12003, 12004 and 12005), with small quantities of pottery, ironwork and clay tobacco pipe, all of 19th-century date, and animal bone recovered from middle fill 12004.

4.11 Trenches 131 and 133-6 (Figs 14 and 16)

- 4.11.1 These trenches were positioned within a narrow part of Land Parcel 49 west of the railway line and Trenches 80, 89, 96 and 100 (see Figs 2 and 11). They revealed a small number of ditches and pits. A ditch in Trench 133 and a posthole in Trench 135 each contained middle Bronze Age/iron Age pottery. Other ditches revealed in Trenches 131 and 135 corresponded with field boundaries shown on historic Ordnance Survey mapping (Fig. 32).
- 4.11.2 **Trench 131** was located to the north of Trench 133 and contained three N-S aligned ditches and a pit. The westernmost ditch (13102) corresponded to a field boundary depicted on the OS maps of 1888-1913. Ditch 13106 lay only 1.7m east of 13102, and ditch 13108, which terminated within the trench, only 0.7m east of 13106. These ditches were probably other phases of the same field boundary. The ditches each had concave profiles, the largest of which (13102) measured 1.15m wide and 0.49m deep (Fig. 16, Section 13100). A horse tooth was recovered from the fill (13107) of ditch 13106, but there were no other finds from this or the other two ditches. Pit 13104 lay south-east of ditch 13108, measured 1.5m in diameter and was at least 0.45m deep. There were no finds, but bulk soil sample 13 collected from fill 13105 produced charcoal, wheat, a possible legume fragment and some burnt flint.
- 4.11.3 **Trench 133** was located to the south of Trench 131 and contained five ditches and seven pits or postholes. Ditch 13313 was aligned WNW-ESE, measured 1.11m wide and 0.38m deep, and had a concave profile (Fig. 16, Section 13303), but was without finds. This cut an earlier and larger ditch 13311, which ran on a SE-NW alignment. No continuation of either ditch

was seen in Trench 130 to the north-west, and it is possible that ditch 13313 and ditch 13319, which lay just north of 13313 and was aligned NNE-SSW, may have formed the west corner of an enclosure that lay largely to the east of the trench. Ditch 13319 was, however, narrower and slightly shallower than 13313, measuring 0.64m wide and 0.31m deep (Fig. 16, Section 13305).

- 4.11.4 Like ditch 13313, ditch 13319 cut a wider ditch, ditch 13317, whose southern end lay within the trench, and was on a NNE-SSW alignment (Fig. 16, Section 13305). Neither ditch 13317 or 13319 contained finds. The earlier and larger ditches may represent the entrance into an earlier enclosure, although the contemporaneity of these ditches was not established. Ditch 13311=13321 was substantial, measuring 1.66m wide and at least 0.59m deep, its south side suggesting a V-shaped profile (Plate 13). Its fill (13312) contained frequent charcoal and burnt clay intrusions and a sherd of Iron Age pottery. Located towards the south of the trench, slightly curvilinear ditch or gully 13303 measured 0.48m wide, 0.11m deep and had a concave profile, but its fill did not contain finds. No continuation of this ditch was seen in Trench 132 to the west.
- 4.11.5 The pits or postholes formed an NNW-SSE alignment, and were in two groups, five being spaced only 1.5m apart south of ditch 13311, and the other two further north after a gap of nearly 12m, spaced 5m apart. The pits or postholes were sub-circular, with diameters ranging from 0.33-0.47m across, but none produced dating evidence. The two that were excavated (13309 and 13315) had similar profiles and were between 0.06m and 0.14m deep (Fig. 16, Section 13303). Pit 13323 cut ditch 13311, though pit 13315 was cut by ditch 13313.
- 4.11.6 **Trench 134** was located to the south-west of Trench 135. It contained a ditch aligned ENE-WSW (13403) and a natural feature (13405). The ditch measured 0.90m wide, 0.26m deep and had a concave profile. Its fill (13404) contained sherds of abraded middle Bronze Age/Iron Age pottery.
- 4.11.7 **Trench 135** was located east of Trench 134 and south-west of Trench 133 and contained the continuation of the westernmost of the N-S aligned ditches found in Trench 131 that corresponding to the boundary shown on the OS maps of 1888-1913 (Fig. 14). Ditch (13503) measured 1.7m in width and 0.63m in depth and had a concave profile. Its fill (13504) contained a sherd of early post-medieval pottery and two pieces of animal bone. This very probably corresponded to ditch 13102. A second ditch (13505) lay 2.5m east of ditch 13503, and may have been another of the parallel ditches seen in Trench 131, although its alignment was more NNE-SSW, and almost in line with ditches 13317 and 13319 in Trench 133. Ditch 13505 measured 1.26m across and 0.22m deep (Fig. 16, Section 13501), but its fill did not contain any finds. To the east was a posthole (13507) that measured 0.34m in diameter and 0.10m deep and its fill (13508) contained abraded pottery dated to the middle Bronze Age/Iron Age.
- 4.11.8 **Trench 136** was located south of Trench 135 and contained an E-W aligned ditch (13603). The ditch measured 1.14m wide and 0.42m deep and had steep, straight sides with a flat base. It contained a sherd of mid-18th century pottery.

4.12 Trenches 137-8 (Figs 15 and 16)

- 4.12.1 These trenches were positioned in the south-west corner of Land Parcel 49, west of the railway line and south of Trench 136. Several pits, two ditches and a posthole were revealed, the last containing prehistoric pottery.
- 4.12.2 **Trench 137** was located to the north of Trench 138. It contained two ditches and three natural features. Ditch 13703 was aligned N-S and had a steep concave profile, measuring 0.56m wide and 0.18m deep (Fig. 16, Section 13700). Ditch 13705 was aligned NE-SW and terminated at its north end within the trench. It measured 0.63m wide, 0.36m deep and contained a fill similar to the natural clay, suggesting it was natural in origin. Neither ditch contained any finds.
- 4.12.3 **Trench 138** was located south of Trench 137. It contained a ditch, a pit, and a posthole. Ditch 13811 lay towards the south end of the trench, was aligned ENE-WSW and measured 0.87m wide and 0.32m deep, with curving sides and a rounded base. Circular pit 13805 was further north, and was 0.60m in diameter and 0.25m deep with a pointed base (Fig. 16, Section 13801). Posthole 13807 was located immediately to the west of the pit and was 0.22m in diameter and 0.11m deep. Bulk soil sample 17 was taken from its fill (13808) and yielded charcoal and a sherd of prehistoric pottery.

4.13 Trenches 150-2 (Figs 17 and 20)

- 4.13.1 These trenches were positioned within the northern part of Land Parcel 40a west of the railway line. They revealed three undated ditches and two tree-throw holes.
- 4.13.2 **Trench 150** was located to the west of Trench 151 and contained two ditches and a tree-throw hole. Ditch 15003 was aligned NE-SW and had a concave profile measuring 1.14m wide and 0.43m deep (Fig. 20, Section 15000). The second ditch (15005) was located along its eastern side, though the relationship between the two ditches was not clear. Ditch 15005 terminated within the trench at its southern end and had a concave profile, measuring at least 0.40m wide and 0.29m deep.
- 4.13.3 **Trench 151** was located between Trenches 150 and 152 and contained a ditch that ran eastwards along the trench for 16.5m before terminating or turning either northwards or southwards. The ditch (15104) measured 1.4m wide and 0.33m deep and had a concave profile (Fig. 20, Section 15100). Its fill (15105) contained pottery dated to c 1200-1350. Bulk soil sample 30 was taken from the fill and yielded a mix of wheat and oat, together with a legume fragment. It is of similar dimensions to ditch 15003 to the west, and this may have been a continuation, although the orientation of ditch 15003 was different, the ditch would have to have been turning, possibly suggesting an enclosure. No continuation was seen in Trench 145 to the north.
- 4.13.4 **Trench 152** was located to the east of Trench 151 and contained a tree-throw hole (15203). Bulk soil sample 28 was taken from its fill (15204)

yielded a charcoal- rich flot, some of which was identified as oak, together with some burnt clay.

4.14 Trenches 155-6 and 158-9 (Figs 18 and 20)

- 4.14.1 These trenches were positioned within the central part of Land Parcel 40a, west of the railway line and south of Trenches 150-152. They revealed several undated ditches.
- 4.14.2 **Trench 155** was located to the north of Trench 156 and contained a ditch aligned NNW-SSE. The ditch (15503) had a concave profile, measuring 0.90m wide and 0.32m deep.
- 4.14.3 **Trench 156** was located to the south-east of Trench 155 and contained a shallow N-S aligned ditch. The ditch (15603) had an uneven, wide profile, measuring 2.01m in width and 0.30m deep (Fig. 20, Section 15600). It contained charcoal and a quantity of cattle bone in its fill (15604), some of which was articulated. No continuation of this ditch was seen in Trench 154 to the north, but it may have continued southwards as ditch 15804.
- 4.14.4 **Trench 158** was located to the south of Trench 156 and contained a single N-S aligned ditch at its west end. This was not fully exposed within the trench, but is likely to be the southern continuation of ditch 15603. The ditch (15804) had a similar profile to the ditch in Trench 156 and measured 1.56m wide and 0.28m deep.
- 4.14.5 **Trench 159** was located to the south of Trench 158 and contained a N-S aligned ditch, most likely the continuation of ditches 15603 and 15804 with which it was in line. The ditch (15903) was steep-sided with a concave base and measured 1.3m wide and 0.32m deep (Fig. 20, Section 15900). Two fragments of animal bone were recovered from its fill (15904).

4.15 Trenches 161, 163 and 166 (Figs 19 and 20)

- 4.15.1 These trenches were positioned within the southern part of Land Parcel 40a, west of the railway line and south of Trenches 159 and 160 and west of Trenches 180, 182 and 184. They revealed several ditches, two postholes and a stakehole, all of which are undated.
- 4.15.2 **Trench 161** was located to the north of Trench 163 and contained a ditch, two postholes, a smaller posthole or stakehole and three natural features. Ditch 16102 was aligned WNW-ESE but was curving as it ran east. It had a concave profile, measuring 0.72m wide and 0.32m deep (Fig. 20, Section 16100), and its greyish-brown sandy silt fill (16103) contained frequent charcoal, three sherds of Iron Age pottery and three fragments of fired clay. Bulk soil sample 27 was taken from the fill and yielded a single charred grain, some charred goosefoot seeds and burnt flint. The two larger postholes (16106 and 16108) and the stakehole were all located adjacent to each other north of the ditch, perhaps suggesting a structure. The postholes measured between 0.16-0.30m in diameter and 0.08-0.17m deep. The stakehole (16109) measured 0.14m in diameter and 0.14m deep (Fig. 20, Section 16102). As it had vertical sides and a flat base, it is more likely to have been a smaller posthole than a driven stake. Bulk sample 29 was taken from its fill (16110) but produced only a poor flot.

- 4.15.3 **Trench 163** was located to the south of Trench 161 and contained a single ditch aligned NNW-SSE, possibly the continuation southwards of ditch 15903, although the orientations are slightly different. The ditch (16302) was 1.48m wide, 0.46m deep and had steep sides and a flat base (Fig. 20, Section 16300).
- 4.15.4 **Trench 166** was located to the south of Trench 163 and contained a narrow ditch, also on a NNW-SSE alignment, but closer to north-south than ditch 16302. The ditch (16602) measured 0.60m wide, 0.20m deep and had a V-shaped profile. No continuation of this ditch was seen on its projected line in Trench 165 to the north.

4.16 Trenches 185-8 (Figs 21 and 23)

- 4.16.1 These trenches were positioned within the northern half of Land Parcel 40c, west of the M25 and east of Pea Lane. They revealed a small number of ditches and pits, the latter of which were dated to the medieval period.
- 4.16.2 **Trench 185** was located at the northern tip of Land Parcel 40c and contained two areas of intercutting pits.
- 4.16.3 At the northern end was a large pit that was recorded in two sequential interventions, the second of which is described here. Pit 18516=18512, located at the north end of the trench, was possibly circular measuring c 3.0m in diameter and 0.98m deep (Fig. 23 Section 18502). It contained two fills, the lower of which (18517=18513) contained some animal bone and patches of burnt clay, together with 15 sherds of pottery dated to c 970-1100, ie the late Anglo-Saxon or Norman period. Bulk sample 31 was taken from the fill but produced a poor flot. Its upper fill (18518) contained pottery dating to c 1000-1225 and fragments of fired clay. It was cut by a second pit (18508=18510=18519), which was possibly circular, 0.40m deep with a flat base, and contained two fills. Its lower fill (18520=18511) contained pottery dated to c 1000-1225. Its upper fill (18509=18521) contained pottery dated to c 1000-1225 and three pieces of slag (88g). Bulk sample 32 was taken from this fill (18509) and produced a good-sized flot. The charcoal, which includes oak, also contains roundwood, whilst the charred grain is largely wheat. Charred legumes and dock seeds are also present.
- 4.16.4 To the south was a large feature measuring up to 10.0m across, possibly representing a group of intercutting pits. A slot excavated into the north side revealed a number of intercutting pits (Fig. 23, Section 18500). Subcircular pit 18504 measured 1.21m across and was 0.37m deep. Its fill (18505) contained pottery dated to c 1050-1225. Bulk sample 33 was taken from the fill and produced a good-sized flot. The charred grain includes wheat and possibly oat together with some charred weed seeds. The charcoal includes oak and field maple. The pit was cut by sub-circular pit 18506, which measured 1.21m across and 0.36m deep. Pit 18502, also possibly sub-circular, measured 1.26m across and 0.32m deep and contained frequent charcoal.
- 4.16.5 **Trench 186** was located to the south of Trench 185 and contained two pits or tree-throws holes. Pit or tree-throw hole 18603 measured 0.86m across and 0.16m deep. The second pit or tree-throw hole (18607) measured 0.38m across and was 0.08m deep. Neither contained finds.

- 4.16.6 **Trench 187** was located to the west of Trench 186 and contained three ditches. Ditch 18706 was aligned NW-SE and measured 0.81m wide and 0.24m deep with a concave profile. It was cut on the south-east side by ditch 18708, which ran NW-SE, measured 1.20m wide and 0.30m deep and also had a concave profile. Ditch 18704 was aligned NE-SW parallel to ditch 18708, and measured 1.76m wide and 0.20m deep with a shallow-sided and broad-based profile. There were no finds in any of these ditches.
- 4.16.7 **Trench 188** was located to the south-west of Trench 187 and contained a single ditch. The ditch (18802) was aligned just to the west of S-N and had a concave profile measuring 1.10m wide and 0.40m deep. The ditch ran parallel and c 9m to the east of a field boundary depicted on the historic OS maps and may have represented either a forerunner of the boundary or the edge of a track that ran alongside it.

4.17 Trenches 190-1, 193, and 196 (Figs 22 and 23)

- 4.17.1 These trenches were positioned within the southern half of Land Parcel 40c, south of Trenches 187 and 188. They revealed several ditches, one of which contained medieval pottery.
- 4.17.2 **Trench 190** was located south-west of Trench 188 near to the western side of Land Parcel 40c and contained a probable ditch and a tree-throw hole. Ditch 19003 was partially exposed at the northern end of the trench and was aligned approximately NE-SW. The ditch had steep sloping sides and a flat base, and was at least 1.0m wide and was 0.36m deep. The fill was without finds.
- 4.17.3 **Trench 191** was located to the east of Trench 190 and contained a single ditch (19102) that measured 0.95m wide and 0.45m deep, with a concave profile. This was in line with ditch 18802 to the north, and was probably a continuation (Fig. 21). There were no finds from the fill.
- 4.17.4 **Trench 193** was located to the south of Trench 190 and contained two ditches, both aligned N-S some 1.5m apart. Ditch 19302 had a slightly uneven, concave profile, and measured 1.94m wide and 0.22m deep (Fig. 23, Section 19300). Ditch 19304 had gently sloping sides and a concave base, and measured 2.1m wide and 0.46m deep. Neither ditch produced finds. No continuation of either ditch was seen in Trench 196 to the south.
- 4.17.5 **Trench 196** was located at the southern end of Land Parcel 40c, south of Trench 193, and contained a single ditch (19602), which was aligned NNW-SSE. The ditch had a concave profile measuring 1.63m wide and 0.49m deep (Fig. 23, Section 19600). There were three fills, the uppermost of which (19605), potentially a tertiary deposit, contained a medieval sherd of pottery dated to c 1275-1350. A piece of burnt flint was recovered from its middle fill (19604).

4.18 Trenches 176, 180 and 183-4 (Figs 24 and 25)

- 4.18.1 These trenches were positioned within the southern half of Land Parcel 40b, the northern half of which contained no archaeological features. The trenches revealed a number of ditches and a pit. Middle Bronze Age/Iron Age pottery was recovered from a ditch in Trench 183 and Iron Age pottery from a ditch in Trench 184.

- 4.18.2 **Trench 176** was located to the north of Trench 180 and contained a shallow and narrow ditch aligned NNE-SSW. The ditch (17603) measured 0.52m wide and 0.05m deep and had a concave profile.
- 4.18.3 **Trench 180** was located south of Trench 176 and north of Trench 183 and contained a NE-SW aligned ditch. The ditch (18003) measured 0.67m wide, 0.19m deep and had a concave profile. It contained two fills, the upper of which contained charcoal flecks, but neither contained artefacts.
- 4.18.4 **Trench 183** was located to the south-east of Trench 180 and contained an E-W ditch. The ditch (18305) measured 1.04m wide, 0.39m deep and had a concave profile (Fig. 25, Section 18300). Its fill (18306) contained pottery dated to the middle Bronze Age/early Iron Age together with a sherd of late Neolithic or early Bronze Age date. No continuation of this ditch was seen in Trench 182 to the west.
- 4.18.5 **Trench 184** was located at the southern limit of Land Parcel 40b and contained six ditches and a pit. Parallel ditches 18407, 18411, 18416 and 18413 were each aligned approximately E-W and perhaps represented a boundary ditch that had been recut on several occasions. The largest and northmost ditch (18413) measured 1.82m wide and 0.48m deep and had a concave profile (Fig. 25, Section 18404). Its lowest fill (18415) comprised bluish grey sandy clay, possibly water deposited. Its upper fill contained small degraded fragments of pottery (not retained) and struck flint. The ditch cut smaller ditch 18416, which measured 0.70m wide and 0.28m deep and had a similar profile (Fig. 25, Section 18404). Its fill (18417) contained a sherd of Iron Age pottery. Ditches 18411 and 18407 were of similar size to ditch 18416, measuring between 0.60-0.70m wide and between 0.13-0.20m deep, and both had single fills (Plate 14). Neither contained any finds.
- 4.18.6 Two ditches were found north of, and cut by, ditch 18413. Ditch 18418 was at right angles running north, and was around 1m wide, but was not excavated. Curvilinear ditch 18405 ran north and then turned eastwards, forming a quarter circle within the trench, but did not continue south of east-west ditches 18413 and 18416. Ditch 18405 measured 0.64m wide, 0.15m deep and had a concave, slightly irregular profile and a single fill (Fig. 25, Section 18400). There were no finds.
- 4.18.7 Pit 18409 was partly exposed in the east side of the trench some 5m south of the ditches, and measured 0.65m wide and 0.30m deep (Fig. 25, Section 18402). It had a single fill that did not contain finds.

4.19 Trench 199-204 (Figs 26 and 27)

- 4.19.1 These trenches were positioned within the northern part of Land Parcel 40d, the land parcel that contained the densest concentration of features. They revealed several ditches, pits, and tree-throw holes. A tree-throw hole in Trench 203 was notable for containing an assemblage of worked flint dating to the Beaker or early Bronze Age period. A ditch in Trench 204 contained pottery of prehistoric or Anglo-Saxon date.
- 4.19.2 **Trench 200** was located at the northern tip of Land Parcel 40d. It contained two ditches and three pits. Both ditches were aligned NNW-SSE and terminated within the trench at their southern ends. Ditch 20005 measured

0.32m wide and 0.15m deep and had a concave profile. Ditch 20007, which lay and about 8m further north, measured 0.43m wide and 0.11m deep and had a concave profile (Fig. 27, Section 20002). Neither ditch contained finds.

- 4.19.3 The largest pit (20009) was only partly exposed within the trench, and was cut by ditch 2007, but appeared to be oval, and measured at least 1m across and at least 0.30m deep, but was not bottomed (Fig. 27, Section 20002). A single fill was exposed, and did not contain finds. Pit 2003, located to the south, was also only partly exposed within the trench, but measured at least 1.02m across and was 0.21m deep with a single, sterile fill. Situated to the north of ditch 20007, circular pit 20011 measured 0.48m in diameter and 0.11m deep. Its fill contained flecks of charcoal but no finds.
- 4.19.4 **Trench 199** was located to the south-east of Trench 200 and contained two NE-SW aligned ditches 2.2m apart and a pit. The more northerly ditch, numbered 19907, terminated at the north end within the trench. It was 0.47m wide and 0.19m deep with a concave profile and a single, sterile fill. Ditch 19905 measured 0.62m wide and 0.06m deep and had a flat base. It contained a fragment of pottery that crumbled upon lifting, and was not retained.
- 4.19.5 Circular pit 19903 measured 0.98m in diameter and 0.23m deep. Its fill contained occasional charcoal flecks but no artefacts.
- 4.19.6 **Trench 201** was located south-west of Trench 200 and west of Trench 202, and contained a ditch and two pits. Ditch 20102 was aligned NE-SW, similar to the ditches in Trenches 199 and 202. The ditch measured 0.59m wide and 0.13m deep with a concave profile and a single fill that was without finds.
- 4.19.7 The larger pit (20107) straddled the trench, but appeared to be oval, and measured at least 3.0m long by 1.85m wide and at least 0.61m deep (Fig. 27, Section 20102), but was not bottomed. The second pit (20105) was also only partly exposed within the trench, but measured at least 1.32m across and at least 0.61m deep, and was also not bottomed. A single fill was exposed in both pits, neither of which contained finds or environmental remains.
- 4.19.8 **Trench 202** was located to the east of Trench 201 and contained a NE-SW aligned ditch and a natural feature. Ditch 20204 measured 0.64m wide, 0.22m deep and had a concave profile. It was filled with greyish-brown sandy clay (20205) that contained a single flint flake.
- 4.19.9 **Trench 203** was located to the south of Trenches 201-2 and contained a pit or tree-throw hole (20304) together with linear features interpreted as of natural origin (20303 and 20305). The pit or tree-throw hole, which was only partly exposed within the trench, was irregular in plan but more regular in profile, and measured 2.59m across and 0.79m deep (Fig. 27, Section 20300; Plate 15). It contained three fills, the bottom one of which (20306) contained several flint scrapers, a fragment of burnt clay and crumbs of pottery of prehistoric date. Bulk sample 18 was taken from this fill but yielded only modern, uncharred goosefoots. Its middle fill (20307) contained charcoal flecks. A flint cobble rubber was recovered from its

upper fill (20308) together with an assemblage of five flint flakes and a scraper. Worked flint comprising three flakes and two scrapers and fragments of fired clay were also recovered from the fill of natural feature (20305) adjacent. The flint tools are diagnostic of Beaker or early Bronze Age flint working, and this represents a significant activity area of this date, perhaps for hide preparation. As the environmental sample yielded modern uncharred seeds, it seems likely that both 20304 and feature 20005 represent tree-throw holes that had disturbed a Beaker/early Bronze Age pit or surface activity area.

- 4.19.10 **Trench 204** was located to the east of Trench 203 and contained a NE-SW aligned ditch and a tree-throw hole. The ditch (20403) measured 1.32m wide and at least 0.51m deep with very steep sides, bowing out on the south-east side, but was not bottomed (Fig. 27, Section 20400). There were two fills side by side with a vertical division between them, possibly indicating a former palisade, or deliberate and careful backfilling. The fill on the north-west side (20404) contained a sherd of pottery of prehistoric or Anglo-Saxon date.

4.20 Trenches 205-14 (Figs 28 and 29)

- 4.20.1 These trenches were positioned south of Trenches 203 and 204 within the central part of Land Parcel 40d. The trenches contained a number of ditches and pits, together with a pond of post-medieval date. A series of parallel ditches in Trenches 208 and 211 closely relate to a boundary shown on the historic OS maps. A ditch revealed in Trench 210 contained middle Bronze Age-early Iron Age pottery and a pit in Trench 212 contained Roman pottery. Further ditches in Trenches 212 and 214 contained post-medieval material.
- 4.20.2 **Trench 205** was located to the west of Trench 206 and contained two features. Pit or possible tree-throw hole 20503 measured 0.90m in diameter and was 0.13m deep. Pit 20505 measured 1.50m in diameter and was 0.44m deep. Both had single fills that were without finds.
- 4.20.3 **Trench 206** was located to the east of Trench 205 and contained the terminus of a NE-SW aligned ditch and a posthole. The ditch terminus (20603) measured 0.83m wide and 0.52m deep with steeply sloping sides and a pointed base, and had a single fill (20604) that contained a moderate amount of charcoal. Posthole 20605 lay immediately adjacent to the ditch on the east side, and measured 0.34m in diameter and 0.09m deep. No finds came from its fill.
- 4.20.4 **Trench 207** was located to the east of Trench 206 and contained an oval pit together with three tree-throw holes. The pit (20706) measured 1.60 long, 0.91m wide and was 0.31m deep, and had a single fill that was without finds. None of the tree-throw holes contained finds.
- 4.20.5 **Trench 208** was located to the south of Trench 205 and contained four ditches and a tree-throw hole. Ditch/gully 20805 was aligned ENE-WSW and had a concave profile, measuring 0.41m wide and 0.13m deep. It was cut at both ends by ditches aligned NNNW-SSE, ditch 20810 on the west and ditch 20803 on the east. Within the confines of the trench it was not

possible to determine if ditch 20805 continued beyond either of the NNW-SSE ditches.

- 4.20.6 Ditches 20810 and 20803 were two of three parallel ditches on the same alignment. Ditch 20803 measured 1.26m wide and 0.40m deep and had sloping sides and a flattish base (Fig. 29, Section 20801). Ditch 20807 ran parallel and 3.5m to the east of ditch 20803, suggesting a trackway. It had an uneven profile, and was 1.38m wide and 0.29m deep. Ditch 20810 at the west end of the trench was not excavated, but lies only 6m east of a field boundary depicted on the historic OS maps, and may well represent a boundary associated with this (Fig. 28).
- 4.20.7 **Trench 209** was located to the east of Trench 208 and contained two ditches. Ditch 20905 was aligned NNW-SSE, but slightly more north-west than the ditch in Trench 208, and had a concave profile measuring 1.05m wide and 0.12m deep. No continuation of this ditch was seen in Trench 206 to the north. Ditch 20903 ran NE-SW and turned south to terminate within the trench at its southern end. It measured 0.57m wide, 0.21m deep and had a concave profile. No finds came from the single fill of either ditch. Although ditch 20905 was wider than 20903, these ditches could have met east of the trench to form the corner of an enclosure.
- 4.20.8 **Trench 210** was located to the east of Trench 209 and contained three ditches. Ditch 21003 was aligned N-S and terminated within the trench at its northern end. It had a concave profile, measuring 0.64m wide and 0.24m deep. Ditch 21005 was aligned NNE-SSW and had a concave profile, measuring 0.82m wide and 0.21m deep (Fig. 29, Section 21001). No finds were recovered from its fill. On its east side ditch 21005 cut ditch 21007 which was also aligned NNE-SSW, and terminated within the trench at its northern end. Ditch 21007 had a concave profile (Fig. 29, Section 21001), and its fill (21006) contained a sherd of pottery dated to middle Bronze Age-early Iron Age.
- 4.20.9 **Trench 211** was located to the south of Trench 208 and contained the southward continuations of the three NW-SE aligned ditches revealed within Trench 208. Ditch 21105, the continuation of ditch 20810, had steep sides and a concave profile, measuring 1.47m wide and 0.62m deep (Plate 16). Ditch 21107, which corresponded to ditch 20803, was not excavated, and the easternmost ditch, ditch 21103, had a concave profile measuring 0.43m wide and 0.05m deep. Although much narrower than ditch 20807 to the north, ditch 21103 is in line with it, and almost certainly represents a continuation of ditch 20807. No continuation of this ditch on the same line was seen in Trench 212 to the south, but it may have become either of ditches 21204 or 21202, both of which were of similar dimensions.
- 4.20.10 **Trench 212** was located to the south of Trench 211 and contained five ditches, a pit and two natural features. Ditch 21204 was aligned NW-SE and was cut by ditches 21202 and 21206 (Fig. 29, Section 21200). It had a V-shaped profile and measured at least 0.34m wide and was 0.27m deep. It was re-cut on its north-east side as ditch 21202, which had a similar profile and depth, and whose fill (21203) contained fragments of brick dated to the 15th-17th centuries. Curvilinear ditch 21206, which cut ditch 21204 on the south-west side, was 1.15m wide and 0.17m deep with a concave

profile. This was cut at the west end by ditch 21210, the later of two ditches (21208 and 21210) that represent the continuation southwards of ditch 21107. The earlier of the two ditches (21208) was 2.08m wide and at least 0.42m deep, but was not bottomed. The later ditch (21210), presumably a re-cut, had a concave profile, measuring 1.28m wide and 0.34m deep. Neither ditch contained finds.

- 4.20.11 Pit 21214 was only partly revealed in the north edge of the trench. It measured at least 1.40m in diameter and was 0.45m deep (Fig. 29, Section 21202). Its fill (21215) contained a pottery sherd dated to AD 200-400. Two other discrete soilmarks in this trench (21212 and 21213) were determined to be of natural origin.
- 4.20.12 **Trench 213** was located to the east of Trench 212 and contained a possible pond and two pits. The possible pond (21302) measured 12.38m across and was machine-excavated to its base at a depth of 1.45m. Its basal fill comprised a grey-brown clayey silt and was overlain by its main fill (21304), which contained fragments of roofing tile and brick dated to the late 15th-17th centuries. Further south, irregular pit 21305 was partly exposed on the east side of the trench. It measured 2.71m across and was 0.45m deep. Bulk soil sample 20 was taken from its fill (21308) and produced a large charcoal-rich flint, together with encrusted charred wheat grains, legume halves, a mix of charred weed seeds and a flint chip. The charcoal included several fragments of oak. Small circular pit 21306 measured 0.28m in diameter and was 0.08m deep, with a single fill but no finds.
- 4.20.13 **Trench 214** was located to the east of Trench 213 and contained a ditch and a tree-throw hole. Ditch 21403 was partly exposed at the west end of the trench, and was aligned ENE-WSW. It had a flat base, and measured at least 0.93m wide and 0.17m deep. Fragments of brick dated to the 15th-17th centuries were recovered from its fill (21404). Tree-throw hole 21405 measured 2.26m in diameter and was approximately 0.78m deep (Fig. 29, Section 21401), although the interface between the lowest fill (21406) and the surrounding natural was unclear due to disturbance. The middle fill (21407) contained two sherds of middle Bronze Age-early Iron Age pottery. Bulk sample 26 was taken from this fill and yielded some charred chaff and straw. The uppermost fill (21408) appears to have been due to tertiary slumping, and was without finds.

4.21 Trenches 216-22 (Figs 30 and 31)

- 4.21.1 These trenches were located within the southern part of Land Parcel 40d south of Trenches 212 and 213, and revealed a number of ditches and pits. A pit in Trench 220 contained an assemblage of late Bronze Age pottery together with much burnt flint. Pits in Trenches 216 and 217 each contained Roman pottery and ditches in Trenches 219 and 220 each contained medieval pottery. Other ditches in Trenches 221 and 222 correspond to field boundaries shown on the historic OS maps.
- 4.21.2 **Trench 216** was located south of Trench 213 and west of Trench 217 and contained two ditches, three pits and a tree-throw hole. Pit 21607 was the earliest of several features in the centre of the trench, and was a pit 2m across but only 0.06m deep (Fig. 31, Section 21600). No finds came from

its single fill. This was cut by a pit or tree-throw hole 21610=21609, which (like pit 21607) was truncated by ditch 21613 on its east side, but measured about 1m wide and was up to 0.53m deep with an irregular base (Fig. 31, Section 21600). Its lower fill (21611) contained brick fragments possibly dating to late 15th-17th centuries. Bulk sample 21 was taken from its fill (21612) and yielded some charcoal. Ditch 21613 was aligned N-S and had steep sides and a flat base, measuring 1.0m wide and 0.41m deep (Fig. 31, Section 21600). It contained two fills, the lower of which (21614) contained pottery dated to AD 1-150, ie of late Iron Age or early Roman date. This fill extended beyond the ditch edge to the west and over the fills of features 21610 and 21607, so the Roman pottery was clearly residual. Ditch 21605 lay further east along the trench, was aligned NW-SE and had a concave profile measuring 0.32m wide and 0.10m deep. It had a single fill devoid of finds.

- 4.21.3 **Trench 217** was located to the east of Trench 216 and contained a ditch aligned N-S, a pit and an E-W land drain. Ditch 21704 was 1.29m wide and 0.25m deep with uneven sides and a concave base. Its fill (21705) contained a flint flake. Pit 21706 was only half-exposed within the trench, but appeared to be circular, measuring 3.15m in diameter and 0.39m deep with steeply sloping sides and a flattish bottom (Fig. 31, Section 21701). There were two fills, and the lower fill (21707) contained a sherd of pottery dated to AD 200-400. Bulk sample 19 was taken from its upper fill (21708) but contained mainly uncharred modern plant debris and seeds, together with a few charred wheat grains.
- 4.21.4 **Trench 218** was located to the south-east of Trench 217 and contained three pits, none fully exposed within the trench, and a posthole. Sub-circular pit 21803 measured 1.51m in diameter and 0.46m deep (Fig. 31, Section 21800). This pit was cut by pit 21809, which measured at least 0.57m across and was 0.16m deep (Fig. 31, Section 21800). Neither pit contained any finds. Further south, sub-oval pit 21805 measured at least 1.68m in length, 0.37m wide and was 0.37m deep. Its fill (21806) contained a flint flake. Circular posthole 21807 measured 0.46m in diameter and 0.22m deep. Bulk sample 22 was taken from its fill (21808) and yielded some charcoal, but there were no finds.
- 4.21.5 **Trench 219** was located to the west of Trench 218 and contained three ditches, a pit, three tree-throw holes and a natural feature. Ditches 21905 and 21908 were both aligned ENE-WSW, and were around 8.5m apart. Ditch 21905 had steep sides and a rectangular slot at its base, and measured 0.95m wide and 0.37m deep. Its fill (21906) contained pottery dated to c 1100-1350 and a 5g CBM fragment dated to the late 15th-17th centuries. Ditch 21908 had a concave profile measuring 0.93m wide and 0.20m deep and its fill (21909) contained pottery dated to 1000-1225. No continuation of the projected line of ditch 21905 was seen in Trench 218 to the east, nor of that of ditch 21908 in Trench 220 to the west. Wider ditch 21913 lay between these two ditches, and was orientated broadly east-west. It measured 1.60m wide and 0.55m deep and had a concave profile (Fig. 31, Section 21903, and Plate 17). Its fill (21914) contained charcoal flecks and pottery dated to c 1000-1225 together with lava fragments and a piece of animal bone. No continuation of this ditch was seen either in

Trench 218 to the east or Trench 220 to the west. Pit 21903 lay south of ditch 21905, and was not fully exposed within the trench, but appeared to be circular and measured 1.25m in diameter and 0.09m deep. No finds were recovered from its single fill.

- 4.21.6 **Trench 220** was located to the west of Trench 219 and contained five ditches, four pits and a posthole. The northernmost ditch (22023) was aligned ENE-WSW and represented the earliest of three intercutting ditches (Fig. 31, Section 22004; Plate 18). Largely removed by the later ditches, it measured at least 0.31m wide and was 0.23m deep. Its fill (22024) contained a 13g CBM fragment dated to the mid-15th-17th centuries and a piece of burnt flint. Ditch 22021, which cut ditch 22023, was aligned approximately E-W, and measured 0.69m wide and 0.31m deep with sloping sides and a rounded base (Plate 18). It was recut as ditch 22018, which was 1.42m wide and 0.52m deep with sloping sides and a base that varied from pointed to rounded (Fig. 31, Section 22004; Plate 18). Its upper fill (22020) contained burnt flint and medieval pottery dated to c 1000-1225 together with a large fragment of tegula tile of Roman date and some animal bone. Sub-rectangular pit 22025 cut ditches 22023, 22021 and 22018, and measured at least 0.65m across and was 0.53m deep with vertical sides and a flattish base (Fig. 31, Section 22004). Its fill (22026) contained a piece of burnt flint, an animal bone fragment and pottery dated to 1000-1225.
- 4.21.7 On the south side ditch 22018 cut a circular pit 22014, which measured 1.21m in diameter and was 0.53m deep, with sides varying from steeply sloping to undercut and a flat base (Fig. 31, Section 22004). It contained three fills, the lowest of which (22015) contained burnt flint and twelve sherds of late Bronze Age/early Iron Age pottery. Its middle fill (22016) contained a sherd of late Bronze Age/Iron Age pottery together with c 260g of burnt flint. Bulk sample 25 from the fill yielded a large charcoal-rich flot that included mainly oak but with some field maple also present. A further 13 sherds of late Bronze Age pottery were recovered from its upper fill (22017) together with c 230g of burnt flint.
- 4.21.8 Ditch 22010, located immediately to the south of pit 22014, and just over a metre south of ditch 22018, was aligned between east-west and ENE-WSW. It had a concave profile, measuring 1.16m wide and 0.34m deep. Its lower fill (22011) contained much burnt flint (c 290g), a piece of animal bone, together with a tiny fragment of CBM dated to the post-medieval period, which was probably intrusive. Posthole 22012 cut ditch 22010 and measured 0.26m in diameter and 0.09m deep, but its fill did not contain finds.
- 4.21.9 Linear feature 22007 was aligned NE-SW and was heavily disturbed by rooting, resulting in an irregular profile measuring 0.39m wide and up to 0.12m deep. Its upper fill (22008) contained charcoal and patches of burnt clay. Bulk sample 24 was taken from the fill and yielded possible charred wheat and oat grains along with a possible legume and some burnt flint, together with possible modern weeds. It is unclear whether this is a gully or a recent agricultural feature. Towards the south end of the trench were pits 22003 and 22005. Circular pit 22003 measured 0.68m in diameter and 0.13m deep, while sub-circular pit 22005 to its north measured 0.63m in

diameter and 0.17m deep. Both contained single fills of mottled blueish-grey and orange-brown silty clay, and neither contained finds.

4.21.10 **Trench 221** was located to the south-west of Trench 220 and contained three ditches. Ditches 22104 and 22105 ran parallel about 1.5m apart on a NNW-SSE alignment. The eastern ditch (22104) was 0.4m wide, the western ditch (22105) around 1m wide, but neither was excavated, as they were also identified and excavated in Trench 222 to the south. Both ditches were cut across by ditch 22102, which was aligned approximately E-W and had a concave profile measuring 0.35m wide and 0.07m deep, with a single fill that did not produce finds. Just east of ditch 22102 was a soilmark some 2.5m wide, also crossing on a NNW-SSE alignment, that may represent a worn hollow alongside the ditches, but was not investigated. Ditches 22104 and 22105 were in line with the ditches identified in Trenches 208, 211 and 212 further north, which followed the same alignment as a field boundary depicted on the historic OS maps, and may have been continuations of these boundaries.

4.21.11 **Trench 222** was located to the south of Trench 221 and contained five parallel and NW-SE aligned ditches and an unexcavated modern ditch (22209). The westernmost two ditches (22212 and 22210) corresponded to ditches 22105 and 22104 in Trench 221 respectively. Ditch 22212 had a concave profile measuring 0.37m wide and 0.13m deep, and ditch 22210 also had a concave profile, measuring 0.60m wide and 0.15m deep. Close to the eastern end of the trench were three further ditches. Ditch 22205 was the earliest of these, and had been cut by ditches 22203 and 22207 on the east and west sides respectively (Plate 19). Ditch 22205 measured at least 0.52m wide and was 0.24m deep with a concave profile. Ditch 22203 had a similar profile and measured 0.75m wide and 0.30m deep. CBM dated to the mid-15th-17th centuries and a cattle bone was recovered from its fill (22204). Ditch 22207 was also similar, measuring 0.84m wide and 0.26m deep. Its fill (22208) contained a piece of burnt flint and a fragment of animal bone. Between these two sets of ditches was a broad soilmark (22209) orientated NNW-SSE that probably corresponded to the broad soilmark in Trench 221 to the north. This was 3.12m wide, but was not excavated. It may represent a hollow worn by traffic along the trackway between the ditches to the west and east.

4.22 Undated features (Fig. 2)

4.22.1 As well as those already mentioned above, further undated archaeological features were identified within Trenches 1-3 and 63, 147, 195 and 215. These comprised a small number of natural features interpreted as probable tree-throw holes. They do not appear to reflect any particular patterns of activity.

4.23 Geoarchaeological assessment (Fig. 33)

4.23.1 A visual assessment of the natural Head and gravel deposits revealed within the bases of the trenches was undertaken by geoarchaeologists at the request of the Archaeological Advisor for GLAAS, Adam Single, during the completion of the trial-trench evaluation of the site. This assessment was carried out to provide greater detail on the underlying superficial

geology due to changes from gravel to Head deposits across the site, as previously mapped by BGS. These deposits are also considered to have the potential to contain Palaeolithic artefacts given the site's proximity to Belhus Woods Country Park, where substantial Palaeolithic material was recovered during the widening of the M25 (M25027.11; Oxford Archaeology 2012), though no finds or deposits of this date were identified within the Boyn Hill sand and gravel deposits during the Ockendon Cutting Palaeolithic watching brief (M25026.11).

- 4.23.2 Whilst a proportion of the evaluation trenches could not be assessed by the geoarchaeologists, as they had already been backfilled or had not yet been excavated at the time of the assessment, Figure 15 indicates that Pleistocene Head deposits were identified across much of the site, with Pleistocene gravel deposits concentrated in the north-east corner. Pleistocene brickearth was revealed in the base of a single trench also located towards the north-east of the site. These results broadly correspond with the data recorded by BGS.

4.24 Finds summary

- 4.24.1 **Prehistoric pottery.** A total of 165 sherds of prehistoric pottery (1178g) and two block-lifted vessels were recovered from Land Parcel 49 during the evaluation. Much of the material dates to the middle Bronze Age and late Bronze Age/iron Age, though sherds of early to middle Neolithic date have also been identified. The two block-lifted vessels (SFs 1 and 2) are of note, being suggestive of placed deposits or having potentially been associated with funerary practices, though no cremated remains were identified.
- 4.24.2 **Roman pottery.** Twelve generally small and worn sherds of Roman pottery, weighing 178g, were collected from contexts concentrated in the northern and southern parts of the site, with some of the material residual in later features. The whole of the Roman period (c AD 43-410) is represented by the small assemblage, suggesting background activity within the landscape during this period.
- 4.24.3 **Medieval and post-medieval pottery.** An assemblage of post-Roman pottery comprising 259 sherds weighing 2957g was collected during the evaluation. A range of pottery dating from the early/mid Anglo-Saxon period to the 19th or early 20th century was identified.
- 4.24.4 **Flint.** Forty-nine pieces of worked flint and 3072g of unworked burnt flint were recovered from the site. Much of the worked flint, which includes blades, flakes and a microlith, was residual in later features and is general thinly distributed across the site. The exceptions are the slightly more substantial assemblages from Trenches 12 and 203, which produced totals of nine and eighteen worked flints and dating to the Mesolithic and Beaker/early Bronze Age periods respectively.
- 4.24.5 The burnt material is largely undiagnostic, the bulk of which was obtained from a ditch in Trench 2 and a pit in Trench 220.
- 4.24.6 **Fired clay.** A small quantity of fired clay (54 fragments, 404g) was retrieved, comprising potential structural fragments from ovens/hearths, a possible briquetage fragment, and pieces of indeterminate form and function. None of this material is securely dated.

- 4.24.7 **Ceramic building materials.** A total of 74 pieces of CBM (7589g) were recovered, the majority consisting of medieval/post-medieval roof tile fragments, though a few pieces of medieval/post-medieval brick and Roman CBM were also identified.
- 4.24.8 **Worked stone.** Thirteen pieces of stone were recovered and retained for analysis. Two pieces (65g) comprise fragments of Mayen lava that may have formed parts of rotary querns and tiny fragments of lava were also recovered from one trench. They may be of Roman or medieval date. The only other worked stone is a flint cobble rubber. The remaining stone is unworked and unused.
- 4.24.9 **Other finds.** A small assemblage of other finds, comprising two clay tobacco pipe fragments (22g), twenty seven metal objects of iron (26, 851g) and lead (1, 48g), including nails and a vessel handle, and seventeen shards of glass (330g), was collected during the evaluation. The majority of these artefacts are dated to the post-medieval/modern period and were found distributed across a number of contexts, reflecting the agricultural nature of land use during this period. In addition, three pieces of smithing slag (88g) were retrieved from a medieval pit in Trench 185.

4.25 Environmental summary

- 4.25.1 **Charred plant remains and charcoal.** A modest quantity of charred plant remains were identified within the 29 bulk soil samples collected during the evaluation, though larger amounts of charcoal were recovered. The charred cereal remains were largely retrieved from medieval features and comprise grains of wheat and possible barley, with a few weed seeds also identified.
- 4.25.2 **Animal bone.** A relatively small assemblage of animal bone, comprising 231 fragments in total (5.164kg), was recovered. The majority of the fragments are of unidentified mammal bones, though some taxa were identified, comprising cattle, horse, sheep/goat, pig, red deer antler, dog, hare, domestic fowl, and rook. Some bones were partially articulated, with others showing signs of gnawing and butchery.
- 4.25.3 **Shell.** A total of 11 pieces of marine shell (171g) were recovered, all of which have been identified as oyster shell.
- 4.25.4 **Human remains.** A small quantity of cremated human remains (5.2g) have been identified. The remains are suggestive of at least one individual, though it was not possible to estimate sex or age, and no pathology, trauma or non-metric traits were observed.

5 Discussion

5.1 Reliability of field investigation

- 5.1.1 The layout of trenches provided good overall coverage of the site and were located to maximise the potential for exposing archaeological remains. However, the need to avoid overhead cables and underground services meant that some small areas could not be investigated.
- 5.1.2 The machining was generally carried out cleanly, providing good visibility of archaeological features and deposits against the underlying natural deposits within the evaluation trenches. Initially some deposits were sample excavated to establish if they were of geological or archaeological origin, and in some cases, putative archaeological features were shown to be no more than variations in natural deposits of silt and clay.
- 5.1.3 The evaluation demonstrated the presence of archaeological remains associated with prehistoric, Roman, medieval, and post-medieval activity. The evaluation results are considered to provide a true reflection of the archaeological potential of the site as highlighted by the detailed WSI (Oxford Archaeology 2020).

5.2 Interpretation

- 5.2.1 **Mesolithic/Neolithic to late Neolithic/early Bronze Age.** A small quantity of worked flint was recovered during the evaluation of the site. Mesolithic activity is proven by a microlith recovered from Trench 27 at the north-east edge of the site. Although much of this material was found as residual finds in later features, there were several concentrations of earlier prehistoric material. In the north-western part of Land Parcel 49 a concentration of 14 struck flints, predominantly blades or bladelets, was recovered from adjacent Trenches 12, 13 and 114, which indicate Mesolithic or early Neolithic activity in the vicinity. A small sherd of early or middle Neolithic pottery from Trench 114 perhaps indicates an earlier Neolithic date. Given the generally small size of domestic Neolithic pits, which makes them difficult to pick up in evaluation, it is possible that early Neolithic features may survive in this area. A sherd of middle Neolithic Peterborough War pottery was also recovered from Trench 21 only 75m to the south-west of this.
- 5.2.2 The other sherd of middle Neolithic pottery was an isolated find, but demonstrates that other scattered activity of middle Neolithic date may be found within this land parcel.
- 5.2.3 In Land Parcel 40 a sherd of late Neolithic or early Bronze Age pottery came from Trench 183, and a tree-throw hole and a natural feature within Trench 203 produced a coherent assemblage of 18 flints including six scrapers characteristic of the Beaker period or early Bronze Age, together with a stone rubber and crumbs of pottery. This represents a focussed activity area, perhaps primarily connected with hide-preparation. A few other struck flints from across the site may indicate background activity of earlier prehistoric date but could also date to the later Bronze Age.

- 5.2.4 **Middle Bronze Age to Iron Age.** In Land Parcel 49 Trench 66 contained two pits of middle Bronze Age date, one containing the base and lower part of a later Bronze Age vessel (SF 2), the other, clay-lined pit sherds making up the rim and upper body of a large Deverel-Rimbury Bucket urn. Both vessels are likely to be of middle Bronze Age date, although no diagnostic features survived on SF 2. The pit containing SF 2 cut a curving ditch that must also be of middle Bronze Age date or earlier. Both pits may have been cremation pits that have been truncated by ploughing, although this seems unlikely with no charred remains or calcined bone present in the surviving deposits. It is more probable that these are purposeful placed deposits within pits with the ditch forming part of a small enclosure.
- 5.2.5 Features of certain late Bronze Age date are few, but at the south end of Land Parcel 40 pit 22014 produced appreciable quantities of diagnostic late Bronze Age pottery, together a large amount of burnt flint. Other pits and ditches within the trench also produced appreciable quantities of burnt flint but were associated with medieval and later dating evidence. It is possible that the burnt flint represents a wider spread of such material of later prehistoric date, and was residual in these features.
- 5.2.6 A second focus of late Bronze Age (or early Iron Age) activity may have lain in the north-east corner of Land Parcel 49, where a ditch aligned roughly N-S that crossed Trenches 27 and 32 contained only pottery of this date. A later pit cut the ditch in Trench 27, and the residual late Bronze Age/early Iron Age pottery found within the pit may also have derived from the earlier ditch.
- 5.2.7 On the south-west edge of Land Parcel 49 a ditch in Trench 100 contained a rimsherd of either late Bronze Age or early Iron Age date, and in adjacent Trench 97 a small vessel of similar date (SF 1) was found placed inverted in a pit. Just west of the railway line Trench 133 contained a ditch that produced a diagnostically early Iron Age rimsherd, perhaps indicating that this group of features may have been of early Iron Age date. Sherds of later prehistoric pottery were also recovered from adjacent Trenches 134 and 135, suggesting a small focus of activity of this period here.
- 5.2.8 Another small focus for activity may lie at the south ends of Land Parcels 40a and 40b, where Trenches 161, 183 and 184 all contained Iron Age or later prehistoric pottery. Trench 161 included a group of postholes and Trench 184 a curving gully that might possibly indicate structures of prehistoric date.
- 5.2.9 A final potential focus may exist towards the south-east of the site within Land Parcel 40d, from which came the remaining bulk of the middle/late-Iron Age pottery, particularly within the southernmost trench (Trench 220).
- 5.2.10 These features and the finds assemblage provide evidence of scattered small foci of activity on site during the later Bronze Age and Iron Age. Sites of the later Bronze Age and Iron Age are very varied in character, and include unenclosed and dispersed settlements of the type possibly indicated by the evaluation results. The evaluation results correspond with remains previously uncovered to the north and south along the line of the M25 Improvements, which consisted of isolated middle or late Bronze Age

cremations or pits, together with a pit alignment (Biddulph and Brady 2015, 24-27 and figs. 15-16).

- 5.2.11 **Roman.** Remains indicative of Roman activity are limited to a few sherds of pottery and pieces of CBM, though early, middle and late Roman material is represented. This demonstrates that activity on site and within the vicinity spanned the whole of the Roman period. Some of this material was residual in later features, suggesting deposition through later agricultural processes. Nevertheless, it is possible that ditches excavated in Trenches 12 and 28 in the north-west of the site are indicative of direct Roman activity on site as are the pits in the southern part of the site in Trenches 212 and 216. A single potential briquetage fragment may also be suggestive of nearby salt working during the Roman period, though a prehistoric date for this fragment is also possible. It is noteworthy that the Roman material was recovered from features concentrated in the north and the south of the site, suggesting that there may have been a focus of activity in these areas of the landscape. The limited remains, however, are indicative of only a low level of Roman activity on site, with more substantial remains having been found to the west at Manor Farm and also further to the north and south.
- 5.2.12 **Medieval.** Three sherds of early/mid Anglo-Saxon pottery (c AD 400-600) recovered from a tree-throw hole in Trench 128 and a sherd potentially of this date from the primary fill of a ditch in Trench 204 provide the only evidence of activity of Anglo-Saxon date on site. This material suggests that, even if only peripherally, early Anglo-Saxon activity recorded to the west at Manor Farm extended into this area of the landscape.
- 5.2.13 The largest concentration of medieval pottery, and potentially the earliest medieval pottery, was found within two large pits, potentially quarries, in Trench 185 on the northern tip of Land Parcel 40c. These assemblages may potentially date to the late Saxon period or immediately after the Norman Conquest during the late 11th or 12th century. These pits also produced the largest assemblages of charred grain, largely wheat, some of which may have sprouted. The trench was located immediately east of Pea Lane which is of least later medieval origin and the evidence here suggests nearby settlement, probably within one of the four manors listed in the Domesday survey for the manorial estate of North and South Ockendon as containing a total of 90 households.
- 5.2.14 Ditches in Trenches 219 and 220 located at the southern end of the site produced a small number of sherds of pottery dating from c 1000-1250 from a group of ditches aligned ENE-WSW. These two trenches were situated immediately to the east of the M25 widening excavations which revealed ditches and possible enclosures of 10th-12th century date, together with pits and postholes suggestive of associated activity (Biddulph and Brady 2015, 26-7 and fig. 16). The predominant alignment of these ditches was the same as that in Trenches 219 and 220, and it is probable that they represent a continuation of this site.
- 5.2.15 An increased intensity of land use occurred later during the medieval period, particularly during c 1270-1400. A number of ditches and pits in Trenches 13, 15 and 16, all located at the north-west corner of the site, contained small quantities of medieval pottery of a domestic nature, with

concentrations of pottery found in Trenches 13 and 15. These remains suggest activity along the edge of the probable medieval precursor to Pike Lane to the west, focussed to the north and east of Trenches 15 and 16. A ditch or possible enclosure containing medieval pottery of this date was also found in Trench 151 on the west side of Land Parcel 140 close to Pea Lane.

- 5.2.16 **Post-medieval.** Evidence of continued land use from the medieval into the post-medieval period is demonstrated by a small assemblage of medieval/post-medieval CBM recovered from ditches and a pit concentrated in Trenches 17-23 in the north-west of the site and from Trenches 203, 213-4, 219-20 and 222 located in the south-east part of the site. The roof tile and brick fragments suggest that a Tudor building may have been situated nearby in proximity to Pike Lane in a landscape occupied by a number of early post-medieval buildings, including North Ockendon Hall, which was rebuilt in red brick in the 16th century. A brick kiln that may have been situated in a field adjacent to Land Parcel 40d during the early post-medieval period, as suggested by a 1775 estate map, could have perhaps produced material for surrounding buildings during this period.
- 5.2.17 Historic OS mapping shows that the layout and agricultural nature of the site and the wider landscape underwent few changes during the late 19th and first half of the 20th century. The site comprises several extant fields, bisected by the London, Tilbury, and Southend Railway line, the M25 and Ockendon Road. Analysis of historic OS maps, however, shows that the site was once divided into a number of smaller fields. The evaluation revealed the remains of a number of ditches across Trenches 6, 30, 22, 33, 39, 47, 53, 54, 59, 68, 88, 102, 106 and 120 within Land Parcel 49, corresponding with late post-medieval field boundaries (Fig. 32). The N-S aligned field boundary shown to have crossed the centre of the southern half of Land Parcel 49, however, was not identified within the evaluation trenches. Three shallow ditches on NNE-SSW alignments investigated in Trench 27 were probably related to post-medieval ploughing. In addition, a ditch revealed across Trenches 14 and 20 may have been related to a path/trackway depicted on late 19th-century mapping close to the parish boundary.
- 5.2.18 Within Land Parcel 40, there were fewer earlier divisions of the existing fields. At the southern end of the site ditches found in Trenches 221 and 222 corresponded to earlier division of the existing field as shown on the historic OS maps together with several parallel ditches that are likely to be associated, perhaps earlier boundaries and/or trackways. Similarly, parallel ditches found in Trenches 208, 211-2, and 221-2 either correspond or are located immediately adjacent to two NW-SE aligned field boundaries shown on the historic OS maps.
- 5.2.19 Post-medieval and modern agricultural activities are also considered to have resulted in the deposition of a few residual finds within ploughsoil and subsoil deposits in Trenches 16, 34, 75, 78, 109 and 114, 134, 217 and 219.

- 5.2.20 **Features of geological and natural origin.** The site contained a number of discrete irregular and sub-circular features suggestive of probable tree-throw holes, root disturbance and animal burrows distributed across the site.
- 5.2.21 In earlier prehistory tree-throw holes were sometimes used as shelters during hunting trips or as repositories for large quantities of finds, and in later periods sometimes contain significant groups of finds, enabling a history of woodland clearance to be charted. On this site, however, only occasional finds that may have been residual have been recovered from tree-throw holes. The earliest datable tree-throw found in Trench 203 with its assemblage of late Neolithic worked flint may have formed from early tree clearance though one in Trench 216 produced post-medieval material, suggesting the survival of trees in parts of the fields. The tree-throw hole recorded in Trench 128, however, is notable for having contained three sherds of early/mid Anglo-Saxon pottery and a piece of possible briquetage of prehistoric or Roman date, though this is likely to have been residual. In addition, a possible pit or tree-throw hole excavated in Trench 34 in the north of the site contained a charcoal-rich fill from which a very small quantity of cremated human remains was recovered. Given the nature of the feature, its fill and the quantity of calcined bone present, the remains are suggestive of the deposition of pyre debris rather than a formal cremation burial. Although undated, these remains are indicative of funerary practices within the vicinity of the site. Whilst no cremated remains were recovered from the middle Bronze Age to Iron Age placed vessels discussed above, it is possible that the remains found in Trench 34 were associated with later prehistoric activity, corresponding with evidence recorded in the surrounding landscape.

5.3 Evaluation objectives and results

- 5.3.1 The trial-trench evaluation is considered to have achieved its general and site-specific aims (see above)
- 5.3.2 **Aims i-iv.** The evaluation established and recorded the presence and extent of archaeological features and deposits in 99 of the 218 trenches investigated. Generally, a low density and low complexity of features, comprising ditches, pits, postholes and natural features such as tree-throw holes, were recorded. All recorded features were found cutting into the natural deposits revealed within the bases of the evaluation trenches.
- 5.3.3 **Aims v-xi.** The evaluation uncovered evidence of Mesolithic, Neolithic, Beaker/early Bronze Age, middle and late Bronze Age and early, middle and late Iron Age, Roman, medieval and post-medieval activity on site. The quantity and range of finds types recovered during the evaluation are generally limited. A focus of early-middle Neolithic activity was identified at the north end of the site, and a concentration of struck flint of Beaker/Early Bronze Age date suggests activity of this date near the southern end of the site. Middle Bronze Age pottery in the north-western part of the site include two near complete vessels suggestive of placed deposits, and a late Bronze Age pit was found at the southern end of the site. A small focus of probable early Iron Age activity was also tentatively identified in the north-western

part of the site, with another towards the south end of the site, including middle Iron Age finds.

- 5.3.4 Roman material was scattered across the site generally as residual finds, though it provides some evidence of activity in this area of the landscape during this period, which may have been related to land use previously recorded at Manor Farm. Archaeological remains of medieval date were concentrated in the west and north-west of the site close to Pea Lane and Pike Lane, in the form of domestic pottery, animal bones, quern fragments and iron slag recovered from ditches and pits. A further focus was found at the very south end of the site adjacent to a previously identified settlement. Early post-medieval activity, mainly identified by pottery and CBM, continued in both the north-west part of the site and at the south end. Continued agricultural land use is evidenced by late post-medieval field boundary ditches encountered across the site, correlating with historic OS maps.
- 5.3.5 Only a modest quantity of environmental remains was recovered during the evaluation. These remains were largely limited to small quantities of charred cereal grains and weed seeds, and greater quantities of charcoal. The majority of the charred cereal grain, largely wheat, was recovered from medieval pits in Trench 185. These remains, particularly those from the medieval features, provide a limited insight into the nature of past land use and economy.
- 5.3.6 Assessment of the underlying geology revealed in the bases of the evaluation trenches demonstrates that much of the site was covered by Pleistocene Head deposits, with Pleistocene gravel deposits concentrated in the north-east corner. These results broadly correspond with the data recorded by BGS.
- 5.3.7 **Aims xiii-xvii.** A small quantity of earlier prehistoric worked flint of generally Mesolithic/Neolithic date, the majority of which was residual in later features, provides limited evidence of earlier prehistoric activity within the wider landscape. Possible colluvial/alluvial deposits were encountered within Trench 13, one of which contained a small quantity of late Bronze Age/early Iron Age pottery, though this may have been residual.
- 5.3.8 Evidence of later prehistoric activity on site is limited to a small number of ditches and pits containing middle Bronze Age and late Bronze Age/early Iron Age pottery. Of note are two pits containing near-complete vessels suggestive of placed deposits. These remains are suggestive of prehistoric activity on site and within the surrounding landscape. Given the overall scarcity of encountered Bronze Age and Iron Age remains, little can be inferred from the evaluation data on the nature of activity on site during these periods.
- 5.3.9 **Aim xviii.** Very limited evidence of Roman activity was revealed by the evaluation. However, the small quantity of Roman pottery and CBM recovered from features in the north of the site, albeit largely as residual finds, suggests that settlement activity recorded at Manor Farm may have extended into this area of the landscape.

- 5.3.10 **Aim xix.** The only firm evidence of Anglo-Saxon date revealed by the evaluation comprises a few sherds of early/mid Anglo-Saxon pottery recovered from a tree-throw hole. This is suggestive of very low-level background activity within the vicinity of the site during this period.
- 5.3.11 **Aims xx-xxii.** Evidence of medieval activity, although limited in quantity and range of features/finds, was concentrated on the northern and south-eastern parts of the site. The former is suggestive of nearby settlement and associated agricultural activity that was probably located along the medieval precursor of Pike Lane adjacent to the site. The latter lay adjacent to 10th-12th activity revealed during earlier excavations situated immediately to the east of the M25 widening.
- 5.3.12 The assemblage of late medieval/post-medieval CBM, which was recovered from ditches and pits also concentrated in the northern and south-eastern part of the site, is suggestive of a nearby Tudor building. No below-ground structural remains, however, were revealed within the evaluation trenches.
- 5.3.13 The evaluation also identified a number of ditches that correspond with the position of field boundaries depicted on late 19th- and early 20th-century OS maps, demonstrating the continued agricultural character of land use.
- 5.3.14 **Aim xxiii.** The assemblage of medieval/post-medieval CBM recovered from the site is suggestive of a nearby Tudor building and may have derived from a local brick-making site, such as that indicated by historic mapping.

Appendix A Trench Tables

Trench 1							
General description					Orientation	NE-SW	
Trench contains two natural features. Trench consists of ploughsoil overlying clay geology.					Length (m)	30	
					Width (m)	2	
					Avg. depth (m)	0.3	
Context No.	Type	Fill Of	Width (m)	Depth (m)	Description	Finds	Date
100	Layer				Natural. Mid brownish orange mixed with light blueish grey silty clay.		
101	Layer		1.8	0.3	Ploughsoil. Mid greyish brown silty clay		
102	Cut		0.55	0.15	Natural Feature. Natural feature, geological. Mid brownish grey, sandy silt, soft		
103	Cut	103	0.85	0.2	Natural Feature. Natural feature, geological. Light brownish grey, sandy silt, soft.		
Trench 2							
General description					Orientation	NW-SE	
Trench contains a natural feature. Trench consists of ploughsoil overlying clay geology.					Length (m)	30	
					Width (m)	2	
					Avg. depth (m)	0.36	
Context No.	Type	Fill Of	Width (m)	Depth (m)	Description	Finds	Date
200	Layer		1.8		Natural. Mid brownish orange clayey sand		
201	Layer		1.8	0.36	Ploughsoil. Mid greyish brown sandy clay		
202	Cut	202	0.6	0.25	Natural Feature. Natural feature, likely geological. Mid brownish grey, sandy silt, soft		
Trench 3							
General description					Orientation	NE-SW	
Trench contains a tree-throw. Trench consists of ploughsoil overlying clay geology.					Length (m)	30	
					Width (m)	2	
					Avg. depth (m)	0.34	
Context No.	Type	Fill Of	Width (m)	Depth (m)	Description	Finds	Date

300	Layer		1.8	0.35	Ploughsoil. Light grey-brown sandy silt		
301	Layer		1.8		Natural. Mid brown-orange silt clay		
302	Cut		0.5	0.2	Natural Feature. Tree-throw, filled by mid brownish grey, sandy silt, soft with frequent manganese.		

Trench 4

General description					Orientation	E-W	
Trench devoid of archaeology. Trench consists of ploughsoil overlying clay geology.					Length (m)	30	
					Width (m)	2	
					Avg. depth (m)	0.34	
Context No.	Type	Fill Of	Width (m)	Depth (m)	Description	Finds	Date
400	Layer		2		Natural. Mid greyish orange clay		
401	Layer		2	0.34	Ploughsoil. Dark orangish brown silty clay.		

Trench 5

General description					Orientation	N-S	
Trench devoid of archaeology. Trench consists of ploughsoil overlying clay geology.					Length (m)	30	
					Width (m)	2	
					Avg. depth (m)	0.33	
Context No.	Type	Fill Of	Width (m)	Depth (m)	Description	Finds	Date
500	Layer		1.8		Natural. Mid greyish orange clayey sand, mixed stone inclusions. Changing to sandy clay in South edge of trench		
501	Layer		1.8	0.33	Ploughsoil. Mid greyish brown sandy clay		

Trench 6

General description					Orientation	E-W	
Trench contains a modern ditch. Trench consists of ploughsoil overlying clay geology.					Length (m)	30	
					Width (m)	2	
					Avg. depth (m)	0.35	
Context No.	Type	Fill Of	Width (m)	Depth (m)	Description	Finds	Date
600	Layer		1.8		Natural. Mid brownish orange clayey sand		
601	Layer		1.8	0.35	Ploughsoil. Mid greyish brown sandy clay		

602	Cut		3.4	0.78	Ditch. Modern boundary ditch seen on historic maps		
603	Fill	602	1.32	0.34	Primary Fill. Light olive brown, silty sand, soft		
604	Fill	602	1.26	0.16	Primary Fill. Light olive brown with reddish brown mottling, silty sand, soft		
605	Fill	602	1.74	0.08	Secondary Fill. Light greyish brown, sandy silt, soft		
606	Fill	602	1.5	0.18	Secondary Fill. Mid brownish grey, sandy silt, soft		
607	Fill	602	1.9	0.24	Secondary Fill. Dark brownish grey, sandy silt, soft		
608	Fill	602	2.9	0.2	Secondary Fill. Mid brownish grey, sandy silt, soft		
609	Fill	602	1.12	0.14	Tertiary Fill. Dark brownish grey, sandy silt, soft		

Trench 7

General description					Orientation	E-W	
Trench devoid of archaeology. Trench consists of ploughsoil overlying clay geology.					Length (m)	30	
					Width (m)	2	
					Avg. depth (m)	0.36	
Context No.	Type	Fill Of	Width (m)	Depth (m)	Description	Finds	Date
700	Layer		2	0.3	Ploughsoil. Light grey-brown sandy silt		
701	Layer		1.8	0.15	Subsoil. Mid grey-brown sandy silt		
702	Layer		1.8		Natural. Mid grey-orange sandy clay		

Trench 8

General description					Orientation	N-S	
Trench contains a geological feature. Trench consists of ploughsoil overlying clay geology.					Length (m)	30	
					Width (m)	2	
					Avg. depth (m)	0.38	
Context No.	Type	Fill Of	Width (m)	Depth (m)	Description	Finds	Date
800	Layer		1.8		Natural. Mid greyish orange clay		
801	Layer		1.8	0.35	Ploughsoil. Dark orangish brown silty clay		
802	Layer		1.8		Natural. Geological feature tested. Light greyish orange clay.		

Trench 9							
General description					Orientation		E-W
Trench devoid of archaeology. Trench consists of ploughsoil overlying clay geology.					Length (m)		30
					Width (m)		2
					Avg. depth (m)		0.36
Context No.	Type	Fill Of	Width (m)	Depth (m)	Description	Finds	Date
900	Layer		1.8		Natural. Mid greyish orange clay		
901	Layer		1.8	0.3	Ploughsoil. Dark orangish brown silty clay		
Trench 10							
General description					Orientation		N-S
Trench devoid of archaeology. Trench consists of ploughsoil and subsoil overlying clay geology.					Length (m)		30
					Width (m)		2
					Avg. depth (m)		0.38
Context No.	Type	Fill Of	Width (m)	Depth (m)	Description	Finds	Date
1000	Layer		1.8	0.2	Ploughsoil. Light grey-brown sandy silt		
1001	Layer		1.8	0.18	Subsoil. Mid grey-brown sandy silt		
1002	Layer		1.8		Natural. Mid grey-orange silt sand		
Trench 11							
General description					Orientation		E-W
Trench devoid of archaeology. Trench consists of ploughsoil and subsoil overlying clay geology.					Length (m)		30
					Width (m)		2
					Avg. depth (m)		0.35
Context No.	Type	Fill Of	Width (m)	Depth (m)	Description	Finds	Date
1100	Layer		1.8	0.15	Ploughsoil. Light grey-brown silt sand		
1101	Layer		1.8	0.1	Subsoil. Mid grey-brown silt sand		
1102	Layer		1.8		Natural. Mid grey-orange sandy clay		
Trench 12							
General description					Orientation		ENE-WSW
Trench revealed several linear ditches including a large WNW-ESE aligned ditch. Consists of ploughsoil overlying subsoil and the natural geology of silty clay head deposit.					Length (m)		30
					Width (m)		2
					Avg. depth (m)		0.55
Context No.	Type	Fill Of	Width (m)	Depth (m)	Description	Finds	Date
1200	Layer		1.8	0.2	Ploughsoil. Mid grey-brown sandy silt	Pb	

1201	Layer		1.8		Natural. Firm mid brown-orange, silty clay	Flint	
1202	Cut		2.94	1.16	Ditch		
1203	Fill	1202	1.8	0.66	Secondary Fill. Soft, light bluish grey, sandy silt	Flint	
1204	Fill	1202	1	0.08	Primary Fill. Mid greyish brown, clayey silt, soft		
1205	Fill	1202	2.32	0.56	Secondary Fill. Mid brownish grey, sandy silt, soft	Pot, animal bone, fired clay, CBM, flint	MBA-IA (res), Roman
1206	Cut		1	0.16	Ditch		
1207	Fill	1206	1	0.16	Secondary Fill. Light brownish grey, sandy clay, soft		
1208	Fill	1202	2.3	0.4	Primary Fill. Mottled greyish brown, silty sandy, soft	Flint	
1209	Cut		0.54	0.16	Natural Feature. Light brownish grey, clayey sand, soft. Animal burrow		
1210	Layer			0.32	Subsoil. Mid greyish brown, clayey sand, soft		
1211	Fill	1202	1.4	0.12	Primary Fill. Mid brownish grey, sandy silt, soft		
1212	Cut		0.96	0.34	Pit		
1213	Fill	1212	0.96	0.34	Primary Fill. Firm mid greyish brown sandy clay. Frequent fired clay nodules (size 20 to 50mm), frequent charcoals (size up to 30mm) and moderate inclusion of natural yellow clay.	Fired clay	
1214	Cut		0.86	0.35	Ditch		
1215	Fill	1214			Secondary Fill		
1216	Fill	1214			Secondary Fill		
1217	Fill				Tertiary Fill		
1218	Cut		1.7	0.56	Ditch		
1219	Fill	1218	1.38	0.46	Secondary Fill. Light bluish grey, silty clay, firm.		
1220	Fill	1218	1	0.26	Secondary Fill. Mid reddish brown, silty clay, firm		

1221	Fill	1218	1.08	0.1	Secondary Fill. Light brownish grey, clayey silt, soft		
1222	Cut		1.16	0.06	Ditch		
1223	Fill	1222	1.16	0.06	Secondary Fill. Mid brownish grey, sandy silt, soft		

Trench 13

General description					Orientation	NE-SW
Trench devoid of archaeology. Consists of ploughsoil overlying clay geology.					Length (m)	30
					Width (m)	2
					Avg. depth (m)	0.4

Context No.	Type	Fill Of	Width (m)	Depth (m)	Description	Finds	Date
1300	Layer		1.8	0.4	Ploughsoil. Mid grey-brown sandy silt		
1301	Layer		1.8		Natural. Mid brown-orange silt clay		
1302	Layer		1.8		Natural. Moderate Light blueish grey clayey silt. Natural feature tested		
1303	Cut		1.2	0.15	Modern. Modern cut in section	Pot, fired clay	AD 1270 -1350
1304	Fill	1303	1.2	0.15	Deliberate Backfill. Dark grey-brown clayey silt. Contains concrete		
1305	Layer			0.41	Colluvial Layer. Mid brownish orange clayey silt		
1306	Layer			0.53	Colluvial Layer. Light greyish blue with brownish orange mottling	Pot	LBA/EIA
1307	Void						
1308	Cut		1.4	0.5	Natural Feature. Seen in section		
1309	Layer			0.25	Alluvial Layer. Dark grey-brownish orange mottling silty clay		
1310	Fill	1308	0.79	0.3	Primary Fill. Dark grey silty clay		

Trench 14

General description					Orientation	NW-SE
Natural sealed by ploughsoil					Length (m)	30
					Width (m)	2
					Avg. depth (m)	0.4

Context No.	Type	Fill Of	Width (m)	Depth (m)	Description	Finds	Date
1400	Layer		1.8	0.3	Ploughsoil. Mid brown-grey sandy silt		

1401	Layer		1.8	0.1	Subsoil. Mid orange-brown sandy silt		
1402	Layer		1.8		Natural. Mid brown-orange silt clay		
1403	Cut		1.95	0.16	Ditch		
1404	Fill	1403	1.95	0.12	Deliberate Backfill. Dark brown, moderately compact, sandy clay with rare fine and small sub angular stones and occasional yellowish clay patches	Fe	

Trench 15

General description					Orientation	E-W	
Trench consists of ploughsoil overlying clay geology.					Length (m)	30	
					Width (m)	2	
					Avg. depth (m)	0.35	
Context No.	Type	Fill Of	Width (m)	Depth (m)	Description	Finds	Date
1500	Layer		1.8	0.36	Ploughsoil. Mid grey-brown sandy silt		
1501	Layer		1.8		Natural. Mid brown-orange silt clay		
1502	Cut		1.45	0.9	Pit		
1503	Fill	1502	1.4	0.27	Deliberate Backfill. Mid brownish grey clay fill. Very compact.	Pot, fired clay	AD 1270 -1350
1504	Fill	1502	1.1	0.24	Secondary Fill. Mid greyish brown clay fill. Very compact.	Pot	AD 1270 -1350
1505	Cut		0.59	0.45	Ditch		
1506	Fill	1505	0.59	0.45	Secondary Fill. Mid grey with brown mottling clay silt.	Pot	MBA-IA
1507	Cut		5.5	0.2	Ditch		
1508	Fill	1507	5.5	0.2	Secondary Fill. Mid greyish orange silty clay no inclusions	Pot, animal bone	AD 1270 -1400

Trench 16

General description					Orientation	N-S	
Trench consists of ploughsoil overlying clay geology.					Length (m)	30	
					Width (m)	2	
					Avg. depth (m)	0.28	
Context No.	Type	Fill Of	Width (m)	Depth (m)	Description	Finds	Date
1600	Layer		1.8	0.28	Ploughsoil. Mid grey-brown sandy silt	Pot	AD 1270 -1350 (res)
1601	Layer		1.8		Natural. Mid orange-brown silt clay		
1602	Cut		1.9	0.4	Ditch		

1603	Fill	1602	1.2	0.2	Primary Fill. soft mid grey-brown silty clay	Pot, animal bone	AD 1270 -1350
1604	Fill	1602	1.2	0.31	Secondary Fill. Firm mid brown-grey silty clay	Pot, animal bone, fired clay	AD 1270 -1350
Trench 17							
General description					Orientation		NE-SW
Trench consists of ploughsoil overlying clay geology.					Length (m)		30
					Width (m)		2
					Avg. depth (m)		0.45
Context No.	Type	Fill Of	Width (m)	Depth (m)	Description	Finds	Date
1700	Layer		1.8	0.45	Ploughsoil. Mid grey-brown sandy silt		
1701	Layer		1.8		Natural. Mid brown-orange silt clay		
1702	Cut		0.59	0.13	Pit. Steep sides, flat base		
1703	Fill	1702	0.59	0.13	Primary Fill. Light grey-brown, silty clay		
1704	Cut		3.94	0.48	Ditch. Modern Ditch, irregular shape		
1705	Fill	1704	3.94	0.48	Primary Fill. Dark grey-brown, silty clay, frequent CBM	Pot, animal bone, Fe, CBM	AD 1670 -1750
1706	Unexcavated feature				Modern. Modern layer		
1707	Cut		2.44	0.61	Ditch		
1708	Fill	1707	2.2	0.4	Primary Fill. Light greyish brown, moderately compact		
1709	Fill	1707	1.24	0.46	Secondary Fill. Mid greyish brown, sandy clay,	Animal bone	
1710	Fill	1707	0.5	0.22	Secondary Fill. Dark greyish brown, clayey sand	CBM	Med/ PMed
1711	Cut		0.62	0.19	Pit. Circular		
1712	Fill	1711	0.62	0.19	Primary Fill. Dark grey with orange mottling clayey silt	Pot	IA
1713	Cut		0.59	0.11	Pit. Circular		
1714	Fill	1713	0.59	0.11	Primary Fill. Dark brownish grey clayey silt	Pot	AD 1200 -1350
Trench 18							
General description					Orientation		NE-SW
					Length (m)		30

Trench contains 5 ditches and 2 natural features. consists of ploughsoil overlying clay geology.						Width (m)	2
						Avg. depth (m)	0.3
Context No.	Type	Fill Of	Width (m)	Depth (m)	Description	Finds	Date
1800	Layer		1.8	0.3	Ploughsoil. Mid brown-grey sandy silt		
1801	Layer		1.8		Natural. Mid orange-grey silt clay		
1802	Unexcavated feature		0.36		Ditch. E/W		
1803	Cut		1.12	0.42	Ditch. NE/SW		
1804	Fill	1803	1.12	0.42	Primary Fill. Light brownish grey silty clay	Pot, animal bone, Fe, CBM, CTP	AD 1580 -1750
1805	Cut		1.59	0.24	Ditch. NE/SW		
1806	Cut		0.66	0.06	Ditch		
1807	Fill	1806	0.66	0.06	Primary Fill. Dark brownish grey clayey silt		
1808	Unexcavated feature		0.17		Modern. Land drain NW/SE		
1809	Fill	1805	1.59	0.24	Primary Fill. Dark grey clayey silt	Pot, animal bone, Fe, CBM	AD 1580 -1750
1810	Unexcavated feature				Modern. Modern curvilinear with CTP and metal objects. Light brownish grey clayey silt		
1811	Cut		0.24	0.1	Natural Feature. Elongated pit. Likely natural/rooting	Animal bone, Fe	
1812	Cut		0.82	0.22	Ditch		
1813	Fill	1812	0.82	0.22	Secondary Fill. Mid brown-grey, silty clay, firm		
1814	Cut		2.8	0.26	Ditch. Base not reached		
1815	Fill	1814	2.8	0.26	Deliberate Backfill. Mid orange-brown, silty clay, compact	Pot, animal bone	AD 1580 -1900
1816	Cut		4.5	0.44	Ditch		
1817	Fill	1816	4.44	0.28	Deliberate Backfill. Dark brown-grey, silty clay, firm	Pot, animal bone, Fe, CBM	AD 1650 -1800
1818	Fill	1816	4.5	0.12	Secondary Fill. Mid grey-brown, silty clay, firm		
Trench 19							

General description						Orientation	E-W
Trench revealed two ditches. Consists of ploughsoil overlying clay geology.						Length (m)	30
						Width (m)	2
						Avg. depth (m)	0.3
Context No.	Type	Fill Of	Width (m)	Depth (m)	Description	Finds	Date
1900	Layer		1.8	0.3	Ploughsoil. Mid grey-brown sandy silt		
1901	Layer		1.8		Natural. Mid brown-orange silt clay		
1902	Cut		1.7	0.48	Ditch		
1903	Fill	1902	1.7	0.26	Primary Fill. Mid bluish grey silty clay		
1904	Fill	1902		0.24	Deliberate Backfill. Very dark grey sandy silt with occasional charcoal flecks.	Pot, CBM, animal bone	Roman (res), Med/ PMed
1905	Cut		0.64	0.45	Ditch		
1906	Fill	1905	0.6	0.2	Primary Fill. Light greenish grey sandy clay	Pot	AD 1480 -1600
1907	Fill	1905	0.65	0.22	Secondary Fill. Light greyish brown clayey sand with moderate hematite inclusions.		
1908	Cut		1.84	0.78	Ditch		
1909	Fill	1908	1.84	0.45	Secondary Fill. Firm dark grey-brown silty clay	Pot, stone, animal bone, CBM	AD 1480 -1600
1910	Fill	1908	1.05	0.36	Primary Fill. Firm mid blue-yellow silty clay		

Trench 20

General description						Orientation	NE-SW
Trench contains one ditch and one pit. Consists of ploughsoil overlying natural geology of clay						Length (m)	30
						Width (m)	2
						Avg. depth (m)	0.35
Context No.	Type	Fill Of	Width (m)	Depth (m)	Description	Finds	Date
2000	Layer		1.8	0.35	Ploughsoil. Mid grey-brown sandy silt		
2001	Layer		1.8		Natural. Mid brown-orange silt clay		
2002	Cut		1.22	0.24	Ditch		
2003	Fill	2002	1.22	0.24	Secondary Fill. Dark brown-grey silty clay		
2004	Cut		0.41	0.06	Pit		
2005	Fill	2004	0.41	0.06	Deliberate Backfill. Dark grey-black silty clay	CBM, animal bone, fired clay	Med/ PMed
2006	Cut		0.26	0.08	Natural Feature		

Trench 21							
General description					Orientation		E-W
Consists of ploughsoil over a subsoil covering a yellowish orange sandy clay natural					Length (m)		30
					Width (m)		2
					Avg. depth (m)		0.4
Context No.	Type	Fill Of	Width (m)	Depth (m)	Description	Finds	Date
2100	Layer		1.8	0.3	Ploughsoil. Mid grey-brown sandy silt		
2101	Layer		1.8	0.1	Subsoil. Mid orange-brown sandy silt		
2102	Layer		1.8		Natural. Mid orange-brown silt clay		
2103	Cut		1.2	0.61	Ditch. N/S		
2104	Fill	2103	0.72	0.25	Primary Fill. Light brownish orange silty clay		
2105	Fill	2103	1.2	0.41	Secondary Fill. Dark brownish grey silty clay	Pot, CBM	MNeo, AD 1550 -1625
2106	Cut		0.3		Modern. Land drain		
Trench 22							
General description					Orientation		NE-SW
Trench contains one ditch. Trench consists of ploughsoil and subsoil overlying clay geology.					Length (m)		30
					Width (m)		2
					Avg. depth (m)		0.4
Context No.	Type	Fill Of	Width (m)	Depth (m)	Description	Finds	Date
2200	Layer		1.8	0.3	Ploughsoil. Mid grey-brown sandy silt		
2201	Layer		1.8		Natural. Mid yellow orange silty sand		
2202	Cut		1.4	0.46	Ditch		
2203	Fill	2202	0.3	0.1	Primary Fill. Dark orange grey silty clay		
2204	Fill	2202	1.11	0.15	Primary Fill. Dark blackish brown silty clay, no inclusions	Glass	1960s
2205	Fill	2202	0.1	0.04	Secondary Fill. Light greyish yellow silty clay		
2206	Fill	2202	0.6	0.25	Secondary Fill. Dark yellowish grey clayey silt no inclusions		
2207	Fill		0.84	0.22	Secondary Fill. Mid yellowish grey sandy silt with bright orange yellow clay patches	Pot, CBM, animal bone	AD 1270 -1400 (res), Med/ PMed
Trench 23							
General description					Orientation		NW-SE

Trench contains a modern pit. Trench consists of ploughsoil overlying clay geology.						Length (m)	24
						Width (m)	2
						Avg. depth (m)	0.38
Context No.	Type	Fill Of	Width (m)	Depth (m)	Description	Finds	Date
2300	Layer		1.8	0.38	Ploughsoil. Mid brown-grey sandy silt		
2301	Layer		1.8		Natural. Mid brown-orange silt clay		
2302	Cut		1.32	0.51	Pit		
2303	Fill	2302	1.32	0.51	Deliberate Backfill. Mid grey with mid brown mottling clay silt.	Pot, CBM	AD 200 - 400
Trench 24							
General description						Orientation	E-W
Trench consists of ploughsoil overlying sand geology.						Length (m)	30
						Width (m)	2
						Avg. depth (m)	0.5
Context No.	Type	Fill Of	Width (m)	Depth (m)	Description	Finds	Date
2400	Layer		1.8	0.3	Ploughsoil. Mid grey-brown sand silt.		
2401	Layer		1.8		Natural. Mid red brown silt sand.		
2402	Layer		1.8		Subsoil. Firm mid brown-grey sandy silt		
2403	Cut		0.68	0.12	Ditch		
2404	Fill	2403	0.68	0.12	Primary Fill. friable light brown-grey silty sand		
2405	Cut		0.46	0.14	Ditch		
2406	Fill	2405	0.46	0.14	Primary Fill. friable light brown-grey silty sand		
2407	Cut		0.68	0.13	Ditch		
2408	Fill	2407	0.68	0.13	Primary Fill. friable mid brown sandy silt		
Trench 25							
General description						Orientation	N-S
Trench devoid of archaeology. Trench consists of ploughsoil and subsoil overlying clay geology.						Length (m)	30
						Width (m)	2
						Avg. depth (m)	0.6
Context No.	Type	Fill Of	Width (m)	Depth (m)	Description	Finds	Date
2500	Layer		1.8	0.3	Ploughsoil. Mid grey-brown sand silt.		
2501	Layer		1.8	0.2	Subsoil. Mid grey-brown sand silt.		
2502	Layer		1.8		Natural. Mid red brown silt clay.		

Trench 26							
General description					Orientation		E-W
Trench devoid of archaeology. Trench consists of ploughsoil overlying sand geology.					Length (m)		30
					Width (m)		2
					Avg. depth (m)		0.4
Context No.	Type	Fill Of	Width (m)	Depth (m)	Description	Finds	Date
2600	Layer		1.8	0.3	Ploughsoil. Mid grey-brown sand silt.		
2601	Layer		1.8		Natural. Mid red brown silt sand.		
Trench 27							
General description					Orientation		NE-SW
Trench contains 1 pit, 1 ditch and 3 plough furrows. Trench consists of ploughsoil overlying natural silt sand.					Length (m)		30
					Width (m)		2
					Avg. depth (m)		0.4
Context No.	Type	Fill Of	Width (m)	Depth (m)	Description	Finds	Date
2700	Layer			0.35	Ploughsoil. Mid grey-brown sand silt.		
2701	Layer				Natural. Mid red brown silt sand.		
2702	Cut		1.9	0.68	Pit		
2703	Fill	2702	2.08	0.12	Primary Fill. Light greyish brown, clayey sand, loose,		
2704	Fill	2702	2.84	0.68	Secondary Fill. Mid blueish grey moderately compact, sandy clay	Pot, CBM	MBA-IA (res), Roman
2705	Fill	2702	2.7	0.15	Secondary Fill. Mid greyish brown, clayey sand, loose, rare rounded stones	Pot, flint	LBA/EIA
2706	Cut		0.45	0.08	Plough Furrow		
2707	Fill	2706	0.45	0.08	Other Fill. Mid greyish brown clayey sand		
2708	Cut		0.42	0.14	Plough Furrow		
2709	Fill	2708	0.42	0.14	Other Fill. Mid greyish brown clayey sand	Pot	AD 270-400
2710	Cut		0.47	0.16	Plough Furrow		
2711	Fill	2710	0.48	0.16	Other Fill. Mid greyish brown clayey sand		
2712	Cut		0.45	0.34	Plough Furrow		
2713	Fill	2712	0.45	0.34	Other Fill. Mid greyish brown clayey sand		
2714	Cut		1.3	0.39	Ditch		
2715	Fill	2714	0.96	0.06	Primary Fill. Light greyish brown, clayey sand, moderately compact		

2716	Fill	2714	1.32	0.22	Secondary Fill. Light greyish brown, clayey sand, loose		
2717	Fill	2714	1.2	0.12	Secondary Fill. Mid greyish brown, clayey sand, loose, occasional rounded stones		
2718	Cut		1.5	0.62	Pit		
2719	Fill	2718	1.3	0.12	Primary Fill. Light greyish brown, clayey sand, loose, frequent hematite and limonite, occasional bioturbation and frequent rounded stones		
2720	Fill	2718	1.3	0.44	Secondary Fill. Mid blueish grey moderately compact, sandy clay, occasional rounded stones and small flint, frequent bioturbation	Pot	LBA/IA
2721	Fill	2718	1.5	0.14	Secondary Fill. Mid greyish brown, clayey sand, loose, rare rounded stones		

Trench 28

General description						Orientation	E-W
Trench contains one ditch. Trench consists of ploughsoil over natural sandy silt.						Length (m)	28
						Width (m)	2
						Avg. depth (m)	0.5
Context No.	Type	Fill Of	Width h (m)	Depth (m)	Description	Finds	Date
2800	Layer		1.8	0.4	Ploughsoil. Mid grey-brown sand silt.		
2801	Layer		1.8		Natural. Mid brown silt clay.		
2802	Cut		1.58	0.68	Ditch		
2803	Fill	2802	1.3	0.68	Secondary Fill. Light bluish grey, sandy silt, soft	Pot	AD 120 - 200
2804	Fill	2802	0.7	0.32	Secondary Fill. Light greyish brown, sandy silt, soft		

Trench 29

General description						Orientation	N-S
Trench contains one ditch. Trench consists of ploughsoil over natural clay silt.						Length (m)	30
						Width (m)	2
						Avg. depth (m)	
Context No.	Type	Fill Of	Width h (m)	Depth (m)	Description	Finds	Date

2900	Layer		1.8	0.4	Ploughsoil. Mid grey-brown clay silt.		
2901	Layer		1.8		Natural. Light brown clay silt.		
2902	Cut		0.81	0.27	Ditch		
2903	Fill	2902	0.81	0.27	Primary Fill. friable light grey silty sand		

Trench 30

General description	Orientation	E-W
Trench revealed one ditch. Consists of ploughsoil overlaying natural geology of silty clay.	Length (m)	30
	Width (m)	2
	Avg. depth (m)	0.5

Context No.	Type	Fill Of	Width (m)	Depth (m)	Description	Finds	Date
3000	Layer		1.8	0.4	Ploughsoil. Mid grey-brown clay silt.		
3001	Layer		1.8		Natural. Mid brown silt clay.		
3002	Cut		1.08	0.4	Ditch. 19th century field boundary		
3003	Fill	3002	0.9	0.3	Secondary Fill. Dark greyish brown sandy silt		
3004	Fill	3002	1.08	0.14	Primary Fill. Mid brownish grey sandy silt merged with orangish clayey sand.		

Trench 31

General description	Orientation	N-S
Trench revealed one ditch. Trench consists of ploughsoil and subsoil overlying natural silty sand.	Length (m)	30
	Width (m)	2
	Avg. depth (m)	0.5

Context No.	Type	Fill Of	Width (m)	Depth (m)	Description	Finds	Date
3100	Layer		1.8	0.35	Ploughsoil. Mid grey-brown sand silt.		
3101	Layer		1.8		Natural. Mid red brown sand silt.		
3102	Cut		1.84	0.44	Ditch		
3103	Fill	3102	1.84	0.44	Primary Fill. friable light white grey silty sand		
3104	Layer		2	0.16	Subsoil. Thin layer of mid brown-grey soft silty sand		

Trench 32

General description	Orientation	E-W
Trench contains one ditch and one pit. Consists of ploughsoil overlaying natural geology of sand	Length (m)	30
	Width (m)	2
	Avg. depth (m)	0.55

Context No.	Type	Fill Of	Width (m)	Depth (m)	Description	Finds	Date
3200	Layer		1.8	0.45	Ploughsoil. Mid grey-brown sand silt.		
3201	Layer		1.8		Natural. Mid yellow brown silt sand.		
3202	Cut		1.5	0.38	Ditch		
3203	Fill	3202	1.5	0.38	Secondary Fill. Mid greyish brown Silty sand Very soft	Pot	LBA/IA
3204	Cut		1.45	0.12	Pit		
3205	Fill	3204	1.45	0.12	Secondary Fill. Light greyish brown Silty sand Moderate soft		

Trench 33

General description	Orientation	E-W
Trench contains one ditch. Trench consists of ploughsoil overlying natural clay silt.	Length (m)	23
	Width (m)	2
	Avg. depth (m)	0.4

Context No.	Type	Fill Of	Width (m)	Depth (m)	Description	Finds	Date
3300	Layer		1.8	0.35	Ploughsoil. Mid grey-brown sand silt.		
3301	Layer		1.8		Natural. Light brown clay silt.		
3302	Cut		1.78	0.64	Ditch		
3303	Fill	3302	1.54	0.54	Secondary Fill. Firm dark grey-brown sandy silt		
3304	Fill	3302	1.2	0.2	Primary Fill. Firm light orange grey silty sand		

Trench 34

General description	Orientation	N-S
Trench contains one pit. Trench consists of ploughsoil overlying sand geology.	Length (m)	30
	Width (m)	2
	Avg. depth (m)	0.4

Context No.	Type	Fill Of	Width (m)	Depth (m)	Description	Finds	Date
3400	Layer		1.8	0.35	Ploughsoil. Mid grey-brown sand silt.	Pot, animal bone, steel	LBA/IA (res)
3401	Layer		1.8		Natural. Light brown sand silt.		
3402	Cut		1.12	0.16	Pit. Possibly tree-throw, very irregular		
3403	Fill	3402	1.12	0.16	Secondary Fill. Mid brownish grey, sandy silt, soft	Burnt human bone	

Trench 35

General description	Orientation	E-W
---------------------	-------------	-----

Trench devoid of archaeology. Trench consists of ploughsoil overlying sand geology.						Length (m)	30
						Width (m)	2
						Avg. depth (m)	0.35
Context No.	Type	Fill Of	Width (m)	Depth (m)	Description	Finds	Date
3500	Layer		1.8	0.3	Ploughsoil. Mid grey-brown sand silt.		
Trench 36							
General description						Orientation	N-S
Trench devoid of archaeology. Trench consists of ploughsoil overlying sand geology.						Length (m)	30
						Width (m)	2
						Avg. depth (m)	0.35
Context No.	Type	Fill Of	Width (m)	Depth (m)	Description	Finds	Date
3600	Layer		1.8	0.3	Ploughsoil. Mid grey-brown sand silt.		
3601	Layer		1.8		Natural. Light brown silt sand.		
Trench 37							
General description						Orientation	E-W
Trench devoid of archaeology. Ploughsoil overlying natural geology.						Length (m)	30
						Width (m)	2
						Avg. depth (m)	0.35
Context No.	Type	Fill Of	Width (m)	Depth (m)	Description	Finds	Date
3700	Layer		1.8	0.3	Ploughsoil. Mid grey-brown clay silt.		
3701	Layer		1.8		Natural. Light grey-brown silt sand.		
Trench 38							
General description						Orientation	N-S
Trench devoid of archaeology. Trench consists of ploughsoil overlying sand geology.						Length (m)	30
						Width (m)	2
						Avg. depth (m)	0.4
Context No.	Type	Fill Of	Width (m)	Depth (m)	Description	Finds	Date
3800	Layer		1.8	0.4	Ploughsoil		
3801	Layer		1.8		Natural.		
Trench 39							
General description						Orientation	E-W
Blank trench. Ploughsoil on top of natural geology.						Length (m)	25
						Width (m)	2
						Avg. depth (m)	0.3
Context No.	Type	Fill Of	Width (m)	Depth (m)	Description	Finds	Date
3900	Layer		1.8	0.25	Ploughsoil. Mid grey-brown clay silt.		

3901	Layer		1.8		Natural. Light grey-brown silt clay.		
3902	Cut		1.54	0.45	Ditch. Modern ditch		
3903	Fill	3902	0.81	0.45	Secondary Fill. Full of modern ditch, pale greyish brown.		
3904	Fill	3902	1.24	0.48	Secondary Fill. Dark brown clayey silt		

Trench 40

General description					Orientation	N-S
Trench devoid of archaeology. Trench consists of ploughsoil overlying clay geology.					Length (m)	30
					Width (m)	2
					Avg. depth (m)	0.35

Context No.	Type	Fill Of	Width (m)	Depth (m)	Description	Finds	Date
4000	Layer		1.8	0.3	Ploughsoil. Mid grey-brown sand silt.		
4001	Layer		1.8		Natural. Light brown silt sand.		

Trench 41

General description					Orientation	E-W
Trench devoid of archaeology. Trench consists of ploughsoil overlying clay geology.					Length (m)	30
					Width (m)	2
					Avg. depth (m)	0.4

Context No.	Type	Fill Of	Width (m)	Depth (m)	Description	Finds	Date
4100	Layer		1.8	0.3	Ploughsoil. Mid grey-brown clay silt.		
4101	Layer		1.8		Natural. Light brown silt clay.		

Trench 42

General description					Orientation	N-S
					Length (m)	30
					Width (m)	2
					Avg. depth (m)	

Context No.	Type	Fill Of	Width (m)	Depth (m)	Description	Finds	Date
4200	Layer		1.8	0.3	Ploughsoil. Mid brown clay silt.		
4201	Layer		1.8		Natural. Light yellow brown silt clay.		

Trench 43

General description					Orientation	E-W
Trench devoid of archaeology. Trench consists of ploughsoil overlying clay geology.					Length (m)	30
					Width (m)	2
					Avg. depth (m)	0.35

Context No.	Type	Fill Of	Width (m)	Depth (m)	Description	Finds	Date
-------------	------	---------	-----------	-----------	-------------	-------	------

4300	Layer		1.8	0.3	Ploughsoil. Mid brown clay silt.		
4301	Layer		1.8		Natural. Mid yellow brown silt clay.		
Trench 44							
General description					Orientation	N-S	
Trench contains one ditch. Trench consists of a ploughsoil overlying a natural of silty sand.					Length (m)	30	
					Width (m)	2	
					Avg. depth (m)	0.3	
Context No.	Type	Fill Of	Width (m)	Depth (m)	Description	Finds	Date
4400	Layer		1.8	0.3	Ploughsoil. Mid brown sand silt.		
4401	Layer		1.8		Natural. Light yellow brown silt sand.	Flint	
4402	Cut		1.66	0.36	Ditch		
4403	Fill	4402	1.66	0.36	Secondary Fill. Light brownish grey, sandy silt soft		
Trench 45							
General description					Orientation	SE-NW	
Trench devoid of archaeology. Trench consists of ploughsoil overlying sand geology.					Length (m)	30	
					Width (m)	2	
					Avg. depth (m)	0.4	
Context No.	Type	Fill Of	Width (m)	Depth (m)	Description	Finds	Date
4500	Layer		1.8	0.35	Ploughsoil. Mid grey-brown sand silt.		
4501	Layer		1.8		Natural. Light red brown silt sand.		
Trench 46							
General description					Orientation	NE-SW	
Trench devoid of archaeology, consists of ploughsoil over mid yellow brown clayey sand natural.					Length (m)	30	
					Width (m)	2	
					Avg. depth (m)	0.45	
Context No.	Type	Fill Of	Width (m)	Depth (m)	Description	Finds	Date
4600	Layer		1.8	0.4	Ploughsoil. Mid greyish brown clayey silt		
4601	Layer		1.8		Natural. Mid yellow brown clayey sand		
Trench 47							
General description					Orientation	N-S	
Trench contained two ditches and a pit. Consists of ploughsoil over mid yellow brown clayey sand natural.					Length (m)	30	
					Width (m)	2	
					Avg. depth (m)	0.41	

Context No.	Type	Fill Of	Width (m)	Depth (m)	Description	Finds	Date
4700	Layer		1.8	0.4	Ploughsoil. Mid greyish brown clayey silt		
4701	Layer		1.8		Natural. Mid yellow brown clayey sand		
4702	Cut		0.74	0.08	Pit		
4703	Fill	4702	0.74	0.08	Secondary Fill. Mid brownish grey, sandy silt, soft	Fired clay	
4704	Cut		1.2	0.24	Ditch		
4705	Fill	4704	1.2	0.24	Secondary Fill. Light brownish grey, sandy silt, soft	Flint	
4706	Cut		0.38	0.44	Ditch		
4707	Fill	4706	0.38	0.36	Secondary Fill. Mid brownish grey, sandy silt, soft		
4708	Fill	4706	0.38	0.14	Tertiary Fill. Dark brownish grey, sandy silt, soft		

Trench 48

General description	Orientation	E-W
Trench devoid of archaeology, consists of ploughsoil over mid yellow brown sandy clay natural.	Length (m)	30
	Width (m)	2
	Avg. depth (m)	0.41

Context No.	Type	Fill Of	Width (m)	Depth (m)	Description	Finds	Date
4800	Layer		1.8	0.4	Ploughsoil. Mid greyish brown clayey silt		
4801	Layer		1.8		Natural. Mid yellow brown clayey sand		

Trench 49

General description	Orientation	N-S
Trench contained possible postholes. Consists of ploughsoil over light white-brown clayey sand natural.	Length (m)	30
	Width (m)	2
	Avg. depth (m)	0.4

Context No.	Type	Fill Of	Width (m)	Depth (m)	Description	Finds	Date
4900	Layer		1.8	0.46	Ploughsoil. Mid greyish brown clayey silt		
4901	Layer		1.8		Natural. Light white-brown clayey sand		

Trench 50

General description	Orientation	E-W
Trench devoid of archaeology. Ploughsoil covering a thick layer of subsoil, sealing natural clay geology.	Length (m)	30
	Width (m)	2

							Avg. depth (m)	0.3
Context No.	Type	Fill Of	Width (m)	Depth (m)	Description	Finds	Date	
5000	Layer		1.8	0.2	Ploughsoil. Mid grey-brown sandy silt			
5001	Layer		1.8	0.1	Subsoil. Mid orange-brown sandy silt			
5002	Layer				Natural. Mid yellow brown silt clay			
Trench 51								
General description					Orientation		N-S	
Trench devoid of archaeology. Ploughsoil covering natural clay geology					Length (m)		30	
					Width (m)		2	
					Avg. depth (m)		0.4	
Context No.	Type	Fill Of	Width (m)	Depth (m)	Description	Finds	Date	
5100	Layer		1.8	0.4	Ploughsoil. Mid grey-brown sandy silt			
5101	Layer		1.8		Natural. Mid orange-brown silt clay			
Trench 52								
General description					Orientation		N-S	
Trench devoid of archaeology. Ploughsoil covering natural clay geology					Length (m)		30	
					Width (m)		3	
					Avg. depth (m)		0.3	
Context No.	Type	Fill Of	Width (m)	Depth (m)	Description	Finds	Date	
5200	Layer		1.8	0.3	Ploughsoil. Mid grey-brown sandy silt			
5201	Layer		1.8		Natural. Mid orange-brown silt clay			
Trench 53								
General description					Orientation		N-S	
Trench contained a modern feature and a pit. Consists of ploughsoil over mid yellow brown clayey sand natural.					Length (m)		30	
					Width (m)		2	
					Avg. depth (m)		0.4	
Context No.	Type	Fill Of	Width (m)	Depth (m)	Description	Finds	Date	
5300	Layer		1.8	0.39	Ploughsoil. Mid greyish brown clayey silt			
5301	Layer		1.8		Natural. Mid yellow brown clayey sand			
5302	Cut		1.5	0.53	Modern. Modern ditch. Not fully excavated due to S edges proximity to bulk.			
5303	Fill	5302	1.5	0.52	Secondary Fill. Contains shotgun pellet remains.			

					Compact, dark greyish brown clayey silt.		
Trench 54							
General description					Orientation	E-W	
Trench contained single ditch. Consists of ploughsoil over mid yellow brown clayey sand natural.					Length (m)	30	
					Width (m)	2	
					Avg. depth (m)	0.4	
Context No.	Type	Fill Of	Width (m)	Depth (m)	Description	Finds	Date
5400	Layer		1.8	0.4	Ploughsoil. Mid greyish brown clayey silt		
5401	Layer		1.8		Natural. Mid yellow brown clayey sand		
5402	Cut		1.4	0.58	Ditch. OS boundary ditch		
5403	Fill	5402	0.2	0.22	Primary Fill. Light greyish brown, Clayey sand, compact, occasional roots, frequent Limonite, rare angular stones		
5404	Fill	5402	0.42	0.96	Secondary Fill. Mid greyish brown, clayey sand, moderately compact, rare charcoal and sub angular stones, occasional patches of light yellowish brown clayey sand		
5405	Fill	5402	1.04	0.33	Secondary Fill. Dark greyish brown, clayey sand, loose, occasional sub angular stones, rare charcoal and roots		
Trench 55							
General description					Orientation	N-S	
Trench devoid of archaeology. Ploughsoil covering the natural clay geology					Length (m)	30	
					Width (m)	2	
					Avg. depth (m)	0.28	
Context No.	Type	Fill Of	Width (m)	Depth (m)	Description	Finds	Date
5500	Layer		1.8	0.28	Ploughsoil. Mid grey-brown sandy silt		
5501	Layer		1.8		Natural. Mid orange-brown silt clay		
Trench 56							
General description					Orientation	E-W	

Ploughsoil covering the natural clay geology						Length (m)	30
						Width (m)	2
						Avg. depth (m)	0.35
Context No.	Type	Fill Of	Width h (m)	Depth (m)	Description	Finds	Date
5600	Layer		1.8	0.35	Ploughsoil. Mid grey-brown sandy silt		
5601	Layer		1.8		Natural. Mid orange-brown silt clay		
Trench 57							
General description						Orientation	NE-SW
Trench devoid of archaeology. Ploughsoil covering a thin layer of subsoil sealing natural clay geology						Length (m)	30
						Width (m)	2
						Avg. depth (m)	0.4
Context No.	Type	Fill Of	Width h (m)	Depth (m)	Description	Finds	Date
5700	Layer		1.8	0.25	Ploughsoil. Mid grey-brown sandy silt		
5701	Layer		1.8	0.15	Subsoil. Mid orange-brown sandy silt		
5702	Layer		1.8		Natural. Mid yellow brown silt clay		
Trench 58							
General description						Orientation	E-W
Ploughsoil covering the natural clay geology						Length (m)	30
						Width (m)	2
						Avg. depth (m)	0.3
Context No.	Type	Fill Of	Width h (m)	Depth (m)	Description	Finds	Date
5800	Layer		1.8	0.3	Ploughsoil. Mid grey-brown sandy silt		
5801	Layer		1.8		Natural. Mid brown-orange silt clay		
5802	Cut		0.46	0.15	Ditch		
5803	Fill	5802	0.46	0.15	Primary Fill. Light brownish grey, clayey sand, friable.		
Trench 59							
General description						Orientation	N-S
Trench revealed one field boundary ditch. Consists of ploughsoil overlaying natural geology of sandy clay.						Length (m)	30
						Width (m)	2
						Avg. depth (m)	0.47
Context No.	Type	Fill Of	Width h (m)	Depth (m)	Description	Finds	Date
5900	Layer		1.8	0.47	Ploughsoil. Mid grey-brown sandy silt		
5901	Layer		1.8		Natural. Mid orange-brown silt clay		
5902	Cut		0.64	0.48	Ditch. 19th century field boundary		

5903	Fill	5902	0.26	0.46	Primary Fill. Mid greyish brown sandy silt with occasional patches of orangish clay.		
5904	Fill	5902	0.64	0.48	Secondary Fill. Dark greyish brown sandy silt with occasional charcoal flecks, small rounded pebbles and sandstone.		

Trench 60

General description		Orientation	SE-NW
Trench devoid of archaeology. Ploughsoil covering natural clay geology		Length (m)	30
		Width (m)	2
		Avg. depth (m)	0.4

Context No.	Type	Fill Of	Width (m)	Depth (m)	Description	Finds	Date
6000	Layer		1.8	0.4	Ploughsoil. Mid grey-brown sandy silt		
6001	Layer		1.8		Natural. Mid orange-brown silt clay		

Trench 61

General description		Orientation	N-S
Trench devoid of archaeology. Trench consists of ploughsoil overlying clay geology.		Length (m)	30
		Width (m)	2
		Avg. depth (m)	0.35

Context No.	Type	Fill Of	Width (m)	Depth (m)	Description	Finds	Date
6100	Layer		1.8	0.3	Ploughsoil. Mid brown clay silt.		
6101	Layer		1.8		Natural. Light yellow brown silt clay.		

Trench 62

General description		Orientation	E-W
Trench devoid of archaeology. Trench consists of ploughsoil overlying clay geology.		Length (m)	30
		Width (m)	2
		Avg. depth (m)	0.35

Context No.	Type	Fill Of	Width (m)	Depth (m)	Description	Finds	Date
6200	Layer		1.8	0.3	Ploughsoil. Mid brown clay silt.		
6201	Layer		1.8		Natural. Light yellow brown silt clay.		

Trench 63

General description		Orientation	N-S
		Length (m)	30
		Width (m)	2
		Avg. depth (m)	0.35

Context No.	Type	Fill Of	Width (m)	Depth (m)	Description	Finds	Date
6300	Layer		1.8	0.3	Ploughsoil. Mid brown clay silt.		
6301	Layer		1.8		Natural. Light yellow brown silt clay.		
6302	Layer		1.8		Natural		
Trench 64							
General description					Orientation	E-W	
Trench investigation shows no features and consists of ploughsoil over light yellow clay sand natural.					Length (m)	30	
					Width (m)	2	
					Avg. depth (m)	0.39	
Context No.	Type	Fill Of	Width (m)	Depth (m)	Description	Finds	Date
6400	Layer		1.8	0.37	Ploughsoil. Mid grey-brown clayey silt		
6401	Layer		1.8		Natural. Light yellow brown clayey sand		
6402	Void						
Trench 65							
General description					Orientation	N-S	
Trench devoid of archaeology, consists of ploughsoil over mid yellow brown clayey sand natural.					Length (m)	30	
					Width (m)	2	
					Avg. depth (m)	0.4	
Context No.	Type	Fill Of	Width (m)	Depth (m)	Description	Finds	Date
6500	Layer		1.8	0.4	Ploughsoil. Mid greyish brown clayey silt		
6501	Layer		1.8		Natural. Mid yellow brown clayey sand		
6502	Void						
Trench 66							
General description					Orientation	E-W	
Trench consists of ploughsoil covering natural clay geology.					Length (m)	30	
					Width (m)	2	
					Avg. depth (m)	0.3	
Context No.	Type	Fill Of	Width (m)	Depth (m)	Description	Finds	Date
6600	Layer		1.8	0.3	Ploughsoil. Mid grey-brown sandy silt		
6601	Layer		1.8		Natural. Mid yellow brown silt clay		
6602	Fill	6603	0.4	0.16	Mid brownish grey, sandy silt, soft. Pit and pot fill. Pot SF 2. No calcined bone present	Pot (SF2)	MBA
6603	Cut		0.4	0.16	Pit. Contains whole pot (SF2).		

6604	Cut		1.2	0.1	Ditch		
6605	Fill	6604	1.2	0.1	Secondary Fill. Mid greyish brown, sandy silt, soft		
6606	Cut		0.76	0.18	Pit. Clay lined pit		
6607	Fill	6606	0.7	0.12	Secondary Fill. Light brownish grey, sandy silt, soft	Pot	MBA
6608	Cut		0.3	0.18	Posthole		
6609	Fill	6608	0.3	0.18	Secondary Fill. Light brownish grey, sandy silt, soft		
6610	Fill	6603	0.4	0.16	Whole pot, same as SF2		
6611	Fill	6606	0.76	0.04	Primary Fill. Light brownish yellow, silty clay, firm		

Trench 67

General description					Orientation	NE-SW	
Trench devoid of archaeology. Ploughsoil covering natural clay geology.					Length (m)	30	
					Width (m)	2	
					Avg. depth (m)	0.35	
Context No.	Type	Fill Of	Width (m)	Depth (m)	Description	Finds	Date
6700	Layer		1.8	0.35	Ploughsoil. Mid grey-brown sandy silt		
6701	Layer		1.8		Natural. Mid orange-brown silt clay		

Trench 68

General description					Orientation	E-W	
Ploughsoil covering natural clay geology					Length (m)	30	
					Width (m)	2	
					Avg. depth (m)	0.36	
Context No.	Type	Fill Of	Width (m)	Depth (m)	Description	Finds	Date
6800	Layer		1.8	0.36	Ploughsoil. Mid grey-brown sandy silt		
6801	Layer		1.8		Natural. Mid orange-brown silt clay		
6802	Unexcavated feature				Ditch. Seen and excavated in tr. 102, 120 and 59.		

Trench 69

General description					Orientation	N-S	
Trench devoid of archaeology. Ploughsoil covering natural clay geology					Length (m)	30	
					Width (m)	2	
					Avg. depth (m)	0.35	
Context No.	Type	Fill Of	Width (m)	Depth (m)	Description	Finds	Date

6900	Layer		1.8	0.35	Ploughsoil. Mid grey-brown sandy silt		
6901	Layer		1.8		Natural. Mid orange-brown silt clay		
Trench 70							
General description					Orientation	E-W	
Trench devoid of archaeology. Ploughsoil covering the natural clay geology					Length (m)	30	
					Width (m)	2	
					Avg. depth (m)	0.32	
Context No.	Type	Fill Of	Width (m)	Depth (m)	Description	Finds	Date
7000	Layer		1.8	0.32	Ploughsoil. Mid grey-brown sandy silt		
7001	Layer		1.8		Natural. Mid orange-brown silt clay		
Trench 71							
General description					Orientation	E-W	
Trench with no archaeology - ploughsoil over natural.					Length (m)	30	
					Width (m)	2	
					Avg. depth (m)	0.45	
Context No.	Type	Fill Of	Width (m)	Depth (m)	Description	Finds	Date
7100	Layer		1.8	0.35	Ploughsoil. Mid brown clay silt.		
7101	Layer		1.8		Natural. Mid red brown silt clay.		
7102	Cut				Natural Feature		
Trench 72							
General description					Orientation	N-S	
Trench devoid of archaeology. Consists of ploughsoil overlaying natural geology of clay.					Length (m)	30	
					Width (m)	2.1	
					Avg. depth (m)	0.35	
Context No.	Type	Fill Of	Width (m)	Depth (m)	Description	Finds	Date
7200	Layer		1.8	0.32	Ploughsoil. Dark grey-brown, silty clay, firm		
7201	Layer		1.8		Natural. Mid brown-orange, silty clay, compact		
Trench 73							
General description					Orientation	E-W	
Trench devoid of archaeology. Trench consists of ploughsoil overlying clay geology.					Length (m)	30	
					Width (m)	2	
					Avg. depth (m)	0.45	
Context No.	Type	Fill Of	Width (m)	Depth (m)	Description	Finds	Date

7300	Layer		1.8	0.4	Ploughsoil. Mid brown clay silt.		
7301	Layer		1.8		Natural. Light yellow brown silt clay.		
Trench 74							
General description					Orientation	N-S	
Trench devoid of archaeology. Trench consists of ploughsoil overlying clay geology.					Length (m)	30	
					Width (m)	2	
					Avg. depth (m)	0.4	
Context No.	Type	Fill Of	Width (m)	Depth (m)	Description	Finds	Date
7400	Layer		1.8	0.35	Ploughsoil. Mid brown clay silt.		
7401	Layer		1.8		Natural. Light yellow brown silt clay.		
Trench 75							
General description					Orientation	E-W	
					Length (m)	30	
					Width (m)	2	
					Avg. depth (m)	0.4	
Context No.	Type	Fill Of	Width (m)	Depth (m)	Description	Finds	Date
7500	Layer		1.8	0.35	Ploughsoil. Mid brown clay silt.		
7501	Layer		1.8		Natural. Mid yellow brown silt clay.	Flint	
Trench 76							
General description					Orientation	N-S	
Trench consists of ploughsoil covering natural clay geology					Length (m)	30	
					Width (m)	2	
					Avg. depth (m)	0.35	
Context No.	Type	Fill Of	Width (m)	Depth (m)	Description	Finds	Date
7600	Layer		1.8	0.35	Ploughsoil. Mid grey-brown sandy silt		
7601	Layer		1.8		Natural. Mid orange-brown silt clay	Flint	
7602	Cut		1.9	0.5	Other Cut. Land drain		
Trench 77							
General description					Orientation	NE-SW	
Ploughsoil covering natural clay geology					Length (m)	30	
					Width (m)	2	
					Avg. depth (m)	0.3	
Context No.	Type	Fill Of	Width (m)	Depth (m)	Description	Finds	Date
7700	Layer		1.8	0.3	Ploughsoil. Mid grey-brown sandy silt		

7701	Layer		1.8		Natural. Mid orange-brown silt clay		
Trench 78							
General description					Orientation	NE-SW	
Trench devoid of archaeology. Ploughsoil covering natural clay geology.					Length (m)	30	
					Width (m)	2	
					Avg. depth (m)	0.38	
Context No.	Type	Fill Of	Width (m)	Depth (m)	Description	Finds	Date
7800	Layer		1.8	0.38	Ploughsoil. Mid grey-brown sandy silt	Flint	
7801	Layer		1.8		Natural. Mid orange-brown silt clay		
7802	Cut		4.8	0.68	Ditch		
7803	Fill	7802	2.1	0.06	Secondary Fill. Mid greyish brown, sandy clay moderately compact, rare rounded stones and occasional limonite	CBM	Med/PMed
7804	Fill	7802	4.14	0.42	Secondary Fill. Mid greyish brown, sandy clay, moderately compact rare rounded stones		
7805	Fill	7802	4.8	0.22	Secondary Fill. Light greyish brown, loose, occasional rounded stones and sandy clay yellow patches		
Trench 79							
General description					Orientation	E-W	
Ploughsoil covering natural clay geology					Length (m)	30	
					Width (m)	2	
					Avg. depth (m)	0.4	
Context No.	Type	Fill Of	Width (m)	Depth (m)	Description	Finds	Date
7900	Layer		1.8	0.4	Ploughsoil. Mid grey-brown sandy silt		
7901	Layer		1.8		Natural. Mid grey-brown silt clay		
7902	Cut				Natural Feature		
Trench 80							
General description					Orientation	NE-SW	
Trench devoid of archaeology. Consists of ploughsoil overlaying natural geology of clay.					Length (m)	28	
					Width (m)	2.1	
					Avg. depth (m)	0.35	
Context No.	Type	Fill Of	Width (m)	Depth (m)	Description	Finds	Date

8000	Layer		1.8	0.32	Ploughsoil. Dark grey-brown, silty clay, firm		
8001	Layer		1.8		Natural. Mid brown-orange, silty clay, compact.		
Trench 81							
General description					Orientation	N-S	
Trench devoid of archaeology. Consists of ploughsoil overlaying natural geology of clay.					Length (m)	30	
					Width (m)	2.1	
					Avg. depth (m)	0.36	
Context No.	Type	Fill Of	Width (m)	Depth (m)	Description	Finds	Date
8100	Layer		1.8	0.32	Ploughsoil. Dark grey-brown, silty clay, firm		
8101	Layer		1.8		Natural. Mid brown-orange, silty clay, compact.		
Trench 82							
General description					Orientation	E-W	
Trench devoid of archaeology. Consists of ploughsoil overlaying natural geology of clay					Length (m)	30	
					Width (m)	2.1	
					Avg. depth (m)	0.36	
Context No.	Type	Fill Of	Width (m)	Depth (m)	Description	Finds	Date
8200	Layer		1.8	0.32	Ploughsoil. Dark grey-brown, silty clay, firm		
8201	Layer		1.8		Natural. Mid brown-orange, silty clay, compact		
Trench 83							
General description					Orientation	N-S	
Trench devoid of archaeology. Consists of ploughsoil overlaying natural geology of clay					Length (m)	30	
					Width (m)	2.1	
					Avg. depth (m)	0.37	
Context No.	Type	Fill Of	Width (m)	Depth (m)	Description	Finds	Date
8300	Layer		1.8	0.33	Ploughsoil. Dark grey-brown, silty clay, firm		
8301	Layer		1.8		Natural. Mid brown-orange, silty clay, compact		
Trench 84							
General description					Orientation	E-W	
					Length (m)	30	
					Width (m)	2	

						Avg. depth (m)	0.45
Context No.	Type	Fill Of	Width (m)	Depth (m)	Description	Finds	Date
8400	Layer		1.8	0.35	Ploughsoil. Mid brown clay silt.		
8401	Layer		1.8		Natural. Light yellow brown silt clay.		
8402	Cut		0.6	0.1	Posthole		
8403	Fill	8402	0.6	0.1	Primary Fill. Firm dark brown-grey sandy silt		
Trench 85							
General description						Orientation	N-S
						Length (m)	30
						Width (m)	2
						Avg. depth (m)	0.4
Context No.	Type	Fill Of	Width (m)	Depth (m)	Description	Finds	Date
8500	Layer		1.8	0.35	Ploughsoil. Mid brown clay silt.		
8501	Layer		1.8		Ploughsoil. Light yellow brown silt clay.		
Trench 86							
General description						Orientation	E-W
Ploughsoil covering natural clay geology						Length (m)	30
						Width (m)	2
						Avg. depth (m)	0.27
Context No.	Type	Fill Of	Width (m)	Depth (m)	Description	Finds	Date
8600	Layer		1.8	0.27	Ploughsoil. Mid grey-brown sandy silt		
8601	Layer		1.8		Natural. Mid orange-brown silt clay		
Trench 87							
General description						Orientation	N-S
Trench devoid of archaeology. Ploughsoil covering the natural clay geology						Length (m)	30
						Width (m)	2
						Avg. depth (m)	0.35
Context No.	Type	Fill Of	Width (m)	Depth (m)	Description	Finds	Date
8700	Layer		1.8	0.35	Ploughsoil. Mid grey-brown sandy silt		
8701	Layer		1.8		Natural. Mid orange-brown silt clay		
Trench 88							
General description						Orientation	NE-SW
Trench contains two ditches and one natural feature. Ploughsoil covering natural clay geology.						Length (m)	30
						Width (m)	2
						Avg. depth (m)	0.3

Context No.	Type	Fill Of	Width (m)	Depth (m)	Description	Finds	Date
8800	Layer		1.8	0.3	Ploughsoil. Mid grey-brown sandy silt		
8801	Layer		1.8		Natural. Mid orange-brown silt clay		
8802	Cut		1.6	0.58	Ditch		
8803	Fill	8802	0.7	0.16	Secondary Fill. Loose dark greyish brown, silty clay.	CBM	C18-19
8804	Fill	8802	0.6	0.3	Primary Fill. Compact light yellowish, silty clay.	CBM	Med/ PMed
8805	Cut		2.3		Ditch. Very modern, not bottomed		
8806	Fill	8805	1.3	0.34	Primary Fill. Light brownish grey, sandy silt, firm		
8807	Fill	8805	1.3	0.22	Secondary Fill. Light brownish grey, clayey silt, soft		
8808	Fill	8805	2	0.56	Secondary Fill. Dark brownish grey, clayey silt, soft		
8809	Fill	8802	1.3	0.56	Secondary Fill. Mid brownish grey, clayey silt, soft		
8810	Cut		0.4	0.2	Natural Feature. Mod greyish brown, clayey silt, soft		

Trench 89

General description	Orientation	NW-SE
Consists of ploughsoil overlaying natural geology of clay	Length (m)	30
	Width (m)	2.1
	Avg. depth (m)	0.34

Context No.	Type	Fill Of	Width (m)	Depth (m)	Description	Finds	Date
8900	Layer		1.8	0.32	Ploughsoil. Dark grey-brown, silty clay, firm		
8901	Layer		1.8		Natural. Mid brown-orange, silty clay, compact		
8902	Cut		0.32	0.24	Ditch. N- S small ditch		
8903	Fill	8902	0.32	0.22	Secondary Fill. Mid brown sandy silt, moderately compact.		
8904	Cut		1.6	0.3	Ditch. N-S Ditch.		
8905	Fill	8904	1.64	0.32	Secondary Fill. Mid brown sandy silt.		

Trench 90

General description	Orientation	N-S
	Length (m)	30

Trench devoid of archaeology. Consists of ploughsoil overlaying natural geology of clay						Width (m)	2.1
						Avg. depth (m)	0.36
Context No.	Type	Fill Of	Width (m)	Depth (m)	Description	Finds	Date
9000	Layer		1.8	0.32	Ploughsoil. Dark grey-brown, silty clay, firm		
9001	Layer		1.8		Natural. Mid brown-orange, silty clay, compact		
9002	Cut				Natural Feature		
Trench 91							
General description						Orientation	N-S
Trench devoid of archaeology. Consists of ploughsoil overlaying natural geology of clay						Length (m)	30
						Width (m)	2.1
						Avg. depth (m)	0.35
Context No.	Type	Fill Of	Width (m)	Depth (m)	Description	Finds	Date
9100	Layer		1.8	0.32	Ploughsoil. Dark grey-brown, silty clay, firm		
9101	Layer		1.8		Natural. Mid brown-orange, silty clay, compact		
Trench 92							
General description						Orientation	N-S
Trench devoid of archaeology. Ploughsoil covering natural clay geology.						Length (m)	30
						Width (m)	2
						Avg. depth (m)	0.4
Context No.	Type	Fill Of	Width (m)	Depth (m)	Description	Finds	Date
9200	Layer		1.8	0.4	Ploughsoil. Mid grey-brown sandy silt		
9201	Layer		1.8		Natural. Mid orange-brown silt clay		
Trench 93							
General description						Orientation	E-W
Trench devoid of archaeology. Ploughsoil covering natural clay geology						Length (m)	30
						Width (m)	2
						Avg. depth (m)	0.35
Context No.	Type	Fill Of	Width (m)	Depth (m)	Description	Finds	Date
9300	Layer		1.8	0.35	Ploughsoil. Mid grey-brown sandy silt		
9301	Layer		1.8		Natural. Mid orange-brown silt clay		
Trench 94							
General description						Orientation	N-S

Ploughsoil covering natural clay geology						Length (m)	30
						Width (m)	2
						Avg. depth (m)	0.25
Context No.	Type	Fill Of	Width (m)	Depth (m)	Description	Finds	Date
9400	Layer		1.8	0.25	Ploughsoil. Mid grey-brown sandy silt		
9401	Layer		1.8		Natural. Mid orange-brown silt clay		
9403	Cut		1.2	0.08	Plough Furrow. Possibly just under stripped sub soil. Mid brownish grey, clayey silt, soft		
Trench 95							
General description						Orientation	E-W
Trench devoid of archaeology. Ploughsoil covering natural clay geology						Length (m)	25
						Width (m)	2
						Avg. depth (m)	0.3
Context No.	Type	Fill Of	Width (m)	Depth (m)	Description	Finds	Date
Trench 96							
General description						Orientation	E-W
Trench consists of ploughsoil overlying clay geology.						Length (m)	30
						Width (m)	2.1
						Avg. depth (m)	0.38
Context No.	Type	Fill Of	Width (m)	Depth (m)	Description	Finds	Date
9600	Layer		1.8	0.34	Ploughsoil. Dark grey-brown, silty clay, firm		
9601	Layer		1.8		Natural. Mid brown-orange, silty clay, compact		
Trench 97							
General description						Orientation	NE-SW
Trench revealed one potential urn grave and two cenotaphs or postholes. Consists of ploughsoil overlying natural geology of sandy clay.						Length (m)	30
						Width (m)	2.1
						Avg. depth (m)	0.37
Context No.	Type	Fill Of	Width (m)	Depth (m)	Description	Finds	Date
9700	Layer		1.8	0.32	Ploughsoil. Dark grey-brown, silty clay, firm		
9701	Layer		1.8		Natural. Mid brown-orange, silty clay, compact		
9702	Cut		0.2	0.04	Other Cut. Cenotaph or Posthole		

9703	Cut		0.22	0.14	Other Cut. Cenotaph or Posthole		
9704	Cut		0.25	0.08	Pit.		
9705	Fill	9704	0.25	0.08	Other Fill. Dark greyish brown, sandy clay, soft. SF1 inverted pot	Pot	LBA/EIA
9706	Fill	9702	0.2	0.04	Deliberate Backfill. Mid brownish grey clayey sand with moderate charcoal flecks.		
9707	Fill	9703	0.22	0.14	Deliberate Backfill. Mid brownish grey clayey sand with occasional rounded sandstone inclusion and frequent charcoal flecks.		

Trench 98

General description	Orientation	NW-SE
Trench consists of ploughsoil overlying clay geology.	Length (m)	30
	Width (m)	2.1
	Avg. depth (m)	0.38

Context No.	Type	Fill Of	Width (m)	Depth (m)	Description	Finds	Date
9800	Layer		1.8		Ploughsoil. Dark grey-brown, silty clay, firm		
9801	Layer		1.8		Natural. Mid brown-orange, silty clay, compact		
9802	Layer		1.8		Subsoil. Mid brown, sandy silt		
9803	Cut		0.71	0.52	Ditch		
9804	Fill	9803	0.71	0.52	Primary Fill. Light greyish brown, mottled, sandy clay, friable.		
9805	Cut		0.51	0.32	Ditch		
9806	Fill	9805	0.51	0.32	Primary Fill. Mid brown, sandy clay, friable.		

Trench 99

General description	Orientation	E-W
Trench devoid of archaeology. Ploughsoil covering natural clay geology	Length (m)	30
	Width (m)	2
	Avg. depth (m)	0.28

Context No.	Type	Fill Of	Width (m)	Depth (m)	Description	Finds	Date
9900	Layer		1.8	0.28	Ploughsoil. Mid grey-brown sandy silt		

9901	Layer		1.8		Natural. Mid orange-brown silt clay		
Trench 100							
General description					Orientation	NW-SE	
Trench consists of ploughsoil overlying clay geology.					Length (m)	30	
					Width (m)	2.1	
					Avg. depth (m)	0.32	
Context No.	Type	Fill Of	Width (m)	Depth (m)	Description	Finds	Date
10000	Layer		1.8	0.28	Ploughsoil. Dark grey-brown, silty clay, firm		
10001	Layer		1.8		Natural. Mid brown-orange, silty clay, compact		
10002	Cut		1.4	0.18	Ditch		
10003	Fill	10002	1.4	0.18	Primary Fill. Firm, light orange-grey clay silt	Pot	LBA
Trench 101							
General description					Orientation	E-W	
Trench devoid of archaeology. Ploughsoil covering natural clay geology.					Length (m)	30	
					Width (m)	2	
					Avg. depth (m)	0.42	
Context No.	Type	Fill Of	Width (m)	Depth (m)	Description	Finds	Date
10100	Layer		1.8	0.42	Ploughsoil. Mid grey-brown sandy silt		
10101	Layer		1.8		Natural. Mid orange-brown silt clay		
Trench 102							
General description					Orientation	E-W	
Trench contained a post-medieval boundary ditch. Trench consists of ploughsoil overlying clay geology.					Length (m)	30	
					Width (m)	2.1	
					Avg. depth (m)	0.38	
Context No.	Type	Fill Of	Width (m)	Depth (m)	Description	Finds	Date
10200	Layer		1.8	0.32	Ploughsoil. Dark grey-brown, silty clay, firm		
10201	Layer		1.8		Natural. Mid brown-orange, silty clay, compact		
10202	Cut		3.2	0.63	Ditch. Post-medieval parish boundary ditch.		
10203	Fill	10202	3.2	0.5	Primary Fill. Mixed fill of firm light yellowish grey and mid-orangish brown, clay loam.		

10204	Fill	10202	2.2	0.13	Secondary Fill. Firm dark greyish brown, clay loam.	Glass	C20th
Trench 103							
General description					Orientation		N-S
Trench devoid of archaeology. Trench consists of ploughsoil overlying clay geology.					Length (m)		30
					Width (m)		2.1
					Avg. depth (m)		0.35
Context No.	Type	Fill Of	Width (m)	Depth (m)	Description	Finds	Date
10300	Layer		1.8	0.33	Ploughsoil. Dark grey-brown, silty clay, firm		
10301	Layer		1.8		Natural. Mid brown-orange, silty clay, compact		
10302	Layer				Natural. Natural features, tested		
10303	Layer				Natural. Natural feature, tested		
Trench 104							
General description					Orientation		E-W
Trench devoid of archaeology. Trench consists of ploughsoil overlying clay geology.					Length (m)		30
					Width (m)		2.1
					Avg. depth (m)		0.33
Context No.	Type	Fill Of	Width (m)	Depth (m)	Description	Finds	Date
10400	Layer		1.8	0.31	Ploughsoil. Dark grey-brown, silty clay, firm		
10401	Layer		1.8		Natural. Mid brown-orange, silty clay, compact		
Trench 105							
General description					Orientation		N-S
Trench consists of ploughsoil overlying clay geology.					Length (m)		30
					Width (m)		2.1
					Avg. depth (m)		0.38
Context No.	Type	Fill Of	Width (m)	Depth (m)	Description	Finds	Date
10500	Layer		1.8		Ploughsoil. Dark grey-brown, silty clay, firm		
10501	Layer		1.8		Natural. Mid brown-orange, silty clay, compact		
10502	Cut		0.73	0.19	Ditch		
10503	Fill		0.73	0.19	Primary Fill. Mid orangish grey clayey sand, very compact.		

Trench 106							
General description					Orientation		E-W
Trench consists of ploughsoil overlying clay geology. Contained one ditch and one pit.					Length (m)		30
					Width (m)		2
					Avg. depth (m)		0.35
Context No.	Type	Fill Of	Width (m)	Depth (m)	Description	Finds	Date
10600	Layer		1.8	0.35	Ploughsoil. Mid grey-brown sandy silt		
10601	Layer		1.8		Natural. Mid brown-orange silt clay		
10602	Cut		0.5	0.16	Pit	Pot	IA
10603	Fill		0.5	0.16	Secondary Fill. Mid greyish brown, silty clay, firm		
10604	Cut		3.35	0.74	Ditch	Pot	MBA-IA, AD 1550 -1900
10605	Fill	10604	3.35	0.3	Tertiary Fill. Mixed mid orangish brown and mid greyish brown silty clay. Soft.	Pot, animal bone, CBM	AD 1580 -1750
10606	Fill	10604	0.68	0.26	Secondary Fill. Light yellowish brown, silty sand. Moderately compact.		
10607	Fill	10604	0.54	0.37	Primary Fill. Mid brown, clayey silt. Soft.		
Trench 107							
General description					Orientation		N-S
Trench devoid of archaeology. Trench consists of ploughsoil overlying clay geology.					Length (m)		30
					Width (m)		2.1
					Avg. depth (m)		0.32
Context No.	Type	Fill Of	Width (m)	Depth (m)	Description	Finds	Date
10700	Layer		1.8	0.32	Ploughsoil. Dark grey-brown, silty clay, firm		
10701	Layer		1.8		Natural. Mid brown-orange, silty clay, compact		
Trench 108							
General description					Orientation		N-S
Trench devoid of archaeology. Ploughsoil covering the natural clay geology					Length (m)		30
					Width (m)		2
					Avg. depth (m)		0.3
Context No.	Type	Fill Of	Width (m)	Depth (m)	Description	Finds	Date
10800	Layer		1.8	0.3	Ploughsoil. Mid grey-brown sandy silt		

10801	Layer		1.8		Natural. Mid orange-brown silt clay		
Trench 109							
General description					Orientation	N-S	
Trench consists of ploughsoil overlying clay geology.					Length (m)	30	
					Width (m)	2.1	
					Avg. depth (m)	0.32	
Context No.	Type	Fill Of	Width (m)	Depth (m)	Description	Finds	Date
10900	Layer		1.8	0.28	Ploughsoil. Dark grey-brown, silty clay, firm	Pot, Fe	AD 1270 -1350 (res)
10901	Layer		1.8		Natural. Mid brown-orange, silty clay, compact		
Trench 110							
General description					Orientation	E-W	
Trench devoid of archaeology. Consists of ploughsoil overlying natural geology of clay.					Length (m)	30	
					Width (m)	2.1	
					Avg. depth (m)	0.38	
Context No.	Type	Fill Of	Width (m)	Depth (m)	Description	Finds	Date
11000	Layer		1.8	0.35	Ploughsoil. Dark grey-brown, silty clay, firm		
11001	Layer		1.8		Natural. Mid brown-orange, silty clay, compact		
Trench 111							
General description					Orientation	N-S	
Trench devoid of archaeology. Trench consists of ploughsoil overlying sand geology.					Length (m)	30	
					Width (m)	2.1	
					Avg. depth (m)	0.36	
Context No.	Type	Fill Of	Width (m)	Depth (m)	Description	Finds	Date
11100	Layer		1.8	0.34	Ploughsoil. Dark grey-brown, silty clay, firm		
11101	Layer		1.8		Natural. Mid brown-orange, silty clay, compact		
Trench 112							
General description					Orientation	E-W	
Trench consists of ploughsoil overlying clay geology.					Length (m)	30	
					Width (m)	2	
					Avg. depth (m)	0.38	
Context No.	Type	Fill Of	Width (m)	Depth (m)	Description	Finds	Date

11200	Layer		1.8	0.38	Ploughsoil. Mid grey-brown sandy silt		
11201	Layer		1.8		Natural. Mid orange-brown silt clay		
11202	Cut		1.66	0.27	Ditch		
11203	Fill	11202	1.66	0.27	Primary Fill	Pot, stone	MNeo
Trench 113							
General description					Orientation	N-S	
Trench devoid of archaeology. Trench consists of ploughsoil overlying clay geology.					Length (m)	30	
					Width (m)	2	
					Avg. depth (m)	0.3	
Context No.	Type	Fill Of	Width (m)	Depth (m)	Description	Finds	Date
11300	Layer		1.8	0.3	Ploughsoil. Mid grey-brown sandy silt		
11301	Layer		1.8		Natural. Mid brown-orange silt clay		
Trench 114							
General description					Orientation	NE-SE	
Trench revealed two curvilinear ditches and a large linear ditch. Consists of ploughsoil and subsoil overlying the natural head deposits.					Length (m)	30	
					Width (m)	2	
					Avg. depth (m)	0.6	
Context No.	Type	Fill Of	Width (m)	Depth (m)	Description	Finds	Date
11400	Layer			0.3	Ploughsoil. Dark yellow grey clayey silt with no inclusions.		
11401	Layer			0.3	Subsoil. Light brownish yellow silty clay with no inclusions	Pot, flint	E-MNeo (res)
11402	Layer				Natural. Light orange yellow sandy clay with frequent rounded pebbles and angular gravel patches	Flint	
11403	Cut		0.47	0.43	Pit		
11404	Fill	11403	0.4	0.35	Primary Fill. Mixed light yellowish grey and dark blackish grey sandy clay with frequent charcoal and burnt clay	Fired clay, flint	
11405	Cut		0.6	0.36	Ditch		
11406	Fill	11405	0.6	0.36	Primary Fill. Mixed mid blueish yellow and mid orange yellow silty clay.		
11407	Unexcavated feature		1.9		Ditch. Filled by mottled light yellowish grey sand and light greyish orange silty		

					clay with occasional angular flint inclusions.		
11408	Fill	11403	0.4	0.25	Primary Fill. Light yellowish grey clayey silt with frequent charcoal and burnt clay inclusions		
11409	Cut	11409	0.4	0.2	Ditch		
11410	Fill	11409	0.4	0.2	Secondary Fill. Light brownish yellow mixed with light yellowish blue silty clay		

Trench 115

General description					Orientation	N-S	
Trench devoid of archaeology. Ploughsoil covering the natural clay geology.					Length (m)	30	
					Width (m)	2	
					Avg. depth (m)	0.32	
Context No.	Type	Fill Of	Width h (m)	Depth (m)	Description	Finds	Date
11500	Layer		1.8	0.33	Ploughsoil. Mid grey-brown sandy silt		
11501	Layer		1.8		Natural. Mid brown-orange silt clay		

Trench 116

General description					Orientation	E-W	
Trench devoid of archaeology. Trench consists of ploughsoil overlying clay geology.					Length (m)	30	
					Width (m)	2	
					Avg. depth (m)	0.25	
Context No.	Type	Fill Of	Width h (m)	Depth (m)	Description	Finds	Date
11600	Layer		1.8	0.25	Ploughsoil. Mid grey-brown sandy silt		
11601	Layer		1.8		Natural. Mid orange-brown silt clay		

Trench 117

General description					Orientation	N-S	
Trench consists of ploughsoil overlying clay geology. 1 pit.					Length (m)	30	
					Width (m)	2	
					Avg. depth (m)	0.42	
Context No.	Type	Fill Of	Width h (m)	Depth (m)	Description	Finds	Date
11700	Layer		1.8	0.42	Ploughsoil. Mid grey-brown sandy silt		
11701	Layer		1.8		Natural. Mid brown-orange silt clay		
11702	Cut		0.94	0.07	Pit		
11703	Fill	11702	0.94	0.07	Primary Fill. Light orangish brown,		

					manganese inclusions		
Trench 118							
General description					Orientation	E-W	
Trench contained a single ditch. Trench consists of ploughsoil overlying natural geology of clay					Length (m)	30	
					Width (m)	2	
					Avg. depth (m)	0.3	
Context No.	Type	Fill Of	Width (m)	Depth (m)	Description	Finds	Date
11800	Layer		1.8	0.3	Ploughsoil. Mid grey-brown sandy silt		
11801	Layer		1.8		Natural. Mid orange-brown silt clay		
11802	Cut		1.3	0.3	Ditch		
11803	Fill	11802	1.3	0.3	Primary Fill		
Trench 119							
General description					Orientation	N-S	
Trench devoid of archaeology. Trench consists of ploughsoil overlying clay geology.					Length (m)	30	
					Width (m)	2	
					Avg. depth (m)	0.3	
Context No.	Type	Fill Of	Width (m)	Depth (m)	Description	Finds	Date
11900	Layer		1.8	0.3	Ploughsoil. Mid grey-brown sandy silt		
11901	Layer		1.8		Natural. Mid orange-brown silt clay		
Trench 120							
General description					Orientation	E-W	
Trench consists of ploughsoil over clay sand natural.					Length (m)	30	
					Width (m)	2	
					Avg. depth (m)	0.28	
Context No.	Type	Fill Of	Width (m)	Depth (m)	Description	Finds	Date
12000	Layer		1.8	0.28	Ploughsoil. Mid grey-brown sandy silt		
12001	Layer		1.8		Natural. Mid orange-brown silt clay		
12002	Cut		1.6	0.48	Ditch		
12003	Fill	12002	0.7	0.13	Tertiary Fill. Firm mid yellow orange sandy silt		
12004	Fill	12002	1.2	0.24	Secondary Fill. friable dark brown-grey sandy silt	Pot, animal bone, Fe, CTP	AD 1805 -1900
12005	Fill	12002	1.6	0.44	Primary Fill. friable dark grey sandy silt		
Trench 121							

General description						Orientation	E-W
Trench devoid of archaeology. Ploughsoil covering natural clay geology.						Length (m)	30
						Width (m)	2
						Avg. depth (m)	0.3
Context No.	Type	Fill Of	Width (m)	Depth (m)	Description	Finds	Date
12100	Layer		1.8	0.32	Ploughsoil. Mid grey-brown sandy silt		
12101	Layer		1.8		Natural. Mid orange-brown silt clay		
Trench 122							
General description						Orientation	N-S
Trench devoid of archaeology. Ploughsoil covering natural clay geology						Length (m)	30
						Width (m)	2
						Avg. depth (m)	0.28
Context No.	Type	Fill Of	Width (m)	Depth (m)	Description	Finds	Date
12200	Layer		1.8	0.28	Ploughsoil. Mid grey-brown sandy silt		
12201	Layer		1.8		Natural. Mid brown-orange silt clay		
Trench 123							
General description						Orientation	E-W
Trench devoid of archaeology. Trench consists of ploughsoil overlying clay geology.						Length (m)	30
						Width (m)	2
						Avg. depth (m)	0.26
Context No.	Type	Fill Of	Width (m)	Depth (m)	Description	Finds	Date
12300	Layer			0.26	Ploughsoil. Mid grey-brown sandy silt		
12301	Layer				Natural. Mid orange-brown silt clay		
Trench 124							
General description						Orientation	N-S
Trench devoid of archaeology. Trench consists of ploughsoil overlying clay geology.						Length (m)	30
						Width (m)	2
						Avg. depth (m)	0.28
Context No.	Type	Fill Of	Width (m)	Depth (m)	Description	Finds	Date
12400	Layer		1.8	0.28	Ploughsoil. Mid grey-brown sandy silt		
12401	Layer		1.8		Natural. Mid orange-brown silt clay		
Trench 125							
General description						Orientation	E-W
Trench devoid of archaeology. Trench consists of ploughsoil overlying sand geology.						Length (m)	30
						Width (m)	2

						Avg. depth (m)	0.4
Context No.	Type	Fill Of	Width (m)	Depth (m)	Description	Finds	Date
12500	Layer		1.8	0.4	Ploughsoil. Mid grey-brown sandy silt		
12501	Layer		1.8		Natural. Mid brown-orange silt sand		
Trench 126							
General description					Orientation		E-W
Trench devoid of archaeology. Trench consists of ploughsoil overlying clay geology.					Length (m)		30
					Width (m)		2
					Avg. depth (m)		0.4
Context No.	Type	Fill Of	Width (m)	Depth (m)	Description	Finds	Date
12600	Layer		1.8	0.4	Ploughsoil. Mid grey-brown sandy silt		
12601	Layer		1.8		Natural. Mid brown-orange silt clay		
Trench 127							
General description					Orientation		N-S
Trench revealed a single shallow pit. Consists of ploughsoil and subsoil overlying the natural geology of silty clay head deposit.					Length (m)		26
					Width (m)		2
					Avg. depth (m)		0.4
Context No.	Type	Fill Of	Width (m)	Depth (m)	Description	Finds	Date
12700	Layer				Ploughsoil		
12701	Layer				Subsoil		
12702	Layer				Natural		
12703	Cut		0.6	0.08	Pit		
12704	Fill	12703	0.6	0.08	Secondary Fill	Flint	
Trench 128							
General description					Orientation		N-S
Trench revealed a single N-S aligned ditch and a tree-throw at its northern end. Consists of ploughsoil overlying subsoil and the natural geology of silty clay					Length (m)		30
					Width (m)		2
					Avg. depth (m)		0.5
Context No.	Type	Fill Of	Width (m)	Depth (m)	Description	Finds	Date
12800	Layer			0.3	Ploughsoil. Dark grey-brown, silty clay.		
12801	Layer			0.25	Subsoil. Brownish grey clay silt.		
12802	Layer				Natural. Mottled light brown gravelly clay and patches of mid grey silty clay.		
12803	Cut				Tree-throw hole. Greyish brown sandy silty clay, manganese rich fill of probable	Pot,	AD 400-600

					tree-throw hole. Not recorded further.		
12804	Unexcavated feature		1.8		Ditch. Linear in plan with mottled greyish brown and light brown silty clay fill.	Fired clay	

Trench 130							
General description					Orientation	N-S	
Trench devoid of archaeology. Consists of ploughsoil and subsoil overlying natural geology of silty clay.					Length (m)	30	
					Width (m)	2	
					Avg. depth (m)	0.58	
Context No.	Type	Fill Of	Width (m)	Depth (m)	Description	Finds	Date
13000	Layer			0.31	Ploughsoil. Dark greyish brown silty clay.		
13001	Layer			0.22	Subsoil. Light greyish brown silty clay.		
13002	Layer				Natural. Light orange brown silty clay.		

Trench 131							
General description					Orientation	NNW-SSE	
Trench revealed 3 ditches and a pit. Consists of ploughsoil and subsoil covering the natural geology of silty clay.					Length (m)	30	
					Width (m)	2	
					Avg. depth (m)	0.55	
Context No.	Type	Fill Of	Width (m)	Depth (m)	Description	Finds	Date
13100	Layer			0.22	Ploughsoil. dark brown grey clayey silt		
13101	Layer			0.21	Subsoil. Red brown clayey silt		
13102	Cut		1.15	0.49	Ditch		
13103	Fill	13102	1.15	0.49	Deliberate Backfill. Dark grey brown clayey silt		
13104	Cut				Pit		
13105	Fill	13104			Primary Fill. Light greyish brown silty clay		
13106	Cut		0.7	0.13	Ditch		
13107	Fill	13106	0.7	0.13	Deliberate Backfill. Medium red brown clayey silt	Animal bone	
13108	Cut				Ditch		
13109	Fill				Deliberate Backfill. medium brown grey clayey silt		
13110	Void						
13111	Layer				Natural. Mid orange brown clayey silt		

Trench 132							
General description					Orientation	W-E	
Trench devoid of archaeology. Consists of ploughsoil and subsoil overlying natural geology of silty clay.					Length (m)	30	
					Width (m)	2	
					Avg. depth (m)	0.65	
Context No.	Type	Fill Of	Width (m)	Depth (m)	Description	Finds	Date
13200	Layer			0.33	Ploughsoil. Dark greyish brown silty clay.		
13201	Layer			0.31	Subsoil. Light greyish brown silty clay.		
13202	Layer				Natural. Light orange brown silty clay		
Trench 133							
General description					Orientation	NNW-SSE	
Trench revealed several ditches and pits. Consisted of a ploughsoil covering a subsoil and mid brownish orange sandy clay natural.					Length (m)	30	
					Width (m)	2	
					Avg. depth (m)	0.44	
Context No.	Type	Fill Of	Width (m)	Depth (m)	Description	Finds	Date
13300	Layer			0.38	Ploughsoil. Dark brownish grey clayey silt		
13301	Layer			0.36	Subsoil. Mid orangeish brown silty clay		
13302	Layer				Natural. Mid brownish orange sandy clay		
13303	Cut		0.48	0.11	Ditch		
13304	Fill	13303	0.48	0.11	Primary Fill. Mid brownish grey compact clayey silt.		
13305	Unexcavated feature		0.33		Pit or posthole. Sub-circular. Dark brownish grey clayey silt with frequent charcoal inclusions.		
13306	Unexcavated feature		0.37		Pit or posthole. Mid greyish brown mod compact clayey silt.		
13307	Unexcavated feature		0.47		Pit or posthole. Mid greyish brown mod compact silty clay		
13308	Unexcavated feature		0.38		Pit or posthole. Sub-circular. Mid brownish grey silty clay		
13309	Cut		0.35	0.09	Pit		
13310	Fill	13309	0.35	0.09	Primary Fill. Mid brownish grey clayey silt		
13311	Cut		1.66	0.59	Ditch		

13312	Fill	13311	1.66	0.59	Primary Fill. Mid greyish brown silty clay with occ charcoal flecks	Pot	EIA
13313	Cut		1.11	0.38	Ditch		
13314	Fill	13313	1.11	0.38	Primary Fill. Dark brownish grey clayey silt		
13315	Cut		0.39	0.06	Pit		
13316	Fill	13315	0.39	0.06	Primary Fill. Dark greyish brown mod compact clayey silt with occ charcoal inclusions		
13317	Cut		0.62	0.31	Ditch		
13318	Fill	13317	0.62	0.31	Primary Fill. Dark brownish grey clayey silt with frequent charcoal and burnt clay inclusions		
13319	Cut		0.64	0.3	Ditch		
13320	Fill	13319	0.64	0.3	Primary Fill. Light brownish grey clayey silt		
13321	Cut		0.4	0.14	Ditch		
13322	Fill	13321	0.4	0.14	Primary Fill. Mid greyish brown clayey silt		
13323	Unexcavated feature		0.33		Pit. Sub circular pit. Dark brownish clayey silt.		

Trench 134

General description		Orientation	NNE-SSW
Trench revealed one linear. Consists of ploughsoil and subsoil overlying natural geology of silty clay.		Length (m)	30
		Width (m)	2
		Avg. depth (m)	0.64

Context No.	Type	Fill Of	Width (m)	Depth (m)	Description	Finds	Date
13400	Layer			0.3	Ploughsoil. Dark greyish brown silty clay		
13401	Layer			0.25	Subsoil. Light greyish brown silty clay.		
13402	Layer				Natural. Lght orange brown silty clay.		
13403	Cut		0.9	0.26	Ditch		
13404	Fill	13403	0.9	0.26	Primary Fill. Light greyish brown clayey silt.	Pot	MBA-IA
13405	Cut		0.28	0.05	Natural Feature		

Trench 135

General description						Orientation	E-W
Trench revealed a post-medieval ditch corresponding to a mapped historic boundary, a second ditch and a posthole. Trench consists of ploughsoil overlying subsoil and the natural geology of silty clay.						Length (m)	30
						Width (m)	2
						Avg. depth (m)	0.5
Context No.	Type	Fill Of	Width (m)	Depth (m)	Description	Finds	Date
13500	Layer			0.34	Ploughsoil. Dark greyish brown silty clay		
13501	Layer			0.23	Subsoil. Mid orangey brown silty clay		
13502	Layer				Natural. Mid orange brown silty clay		
13503	Cut		1.7	0.63	Ditch		
13504	Fill	13503	1.7	0.63	Secondary Fill. Mid greyish brown silty clay	Pot, animal bone	c 1550-1700
13505	Cut		1.26	0.22	Ditch		
13506	Fill	13505	1.26	0.22	Secondary Fill. Mid orangey brown silty clay with black manganese mottling		
13507	Cut		0.34	0.1	Posthole		
13508	Fill	13507	0.34	0.1	Secondary Fill. Mid greyish brown silty clay with occasional charcoal flecks	Pot	MBA-IA
Trench 136							
General description						Orientation	NNW-SSE
Trench revealed one ditch. Consists of ploughsoil and subsoil overlying natural geology of silty clay.						Length (m)	30
						Width (m)	2
						Avg. depth (m)	0.74
Context No.	Type	Fill Of	Width (m)	Depth (m)	Description	Finds	Date
13600	Layer			0.4	Ploughsoil. Mid blackish grey, slightly clayey silt.		
13601	Layer			0.32	Subsoil. Mid brown, slightly sandy silt.		
13602	Layer				Natural. Mid reddish brown, silty clay		
13603	Cut		1.14	0.42	Ditch		
13604	Fill	13603	1.14	0.42	Primary Fill. Mid greyish brown, clayey silt.	Pot	c 1750-1780
Trench 137							
General description						Orientation	NNW-SSE
						Length (m)	30
						Width (m)	2

Trench revealed two ditches, one of which is a terminus. Trench itself consists of ploughsoil and subsoil overlying natural geology of silty clay.						Avg. depth (m)	0.43
Context No.	Type	Fill Of	Width (m)	Depth (m)	Description	Finds	Date
13700	Layer			0.33	Ploughsoil. Dark greyish brown silty clay.		
13701	Layer			0.12	Subsoil. Light greyish brown silty clay.		
13702	Layer				Natural. Light greyish orange silty clay.		
13703	Cut		0.56	0.18	Ditch		
13704	Fill	13703	0.56	0.18	Primary Fill. Light brownish grey clayey silt.		
13705	Cut		0.63	0.36	Ditch		
13706	Fill	13705	0.63	0.36	Primary Fill. Firm light yellowish grey clayey silt.		
13707	Cut		0.62	0.09	Natural Feature		
13708	Cut		0.21	0.05	Natural Feature		
13709	Cut		0.44	0.1	Natural Feature		

Trench 138

General description						Orientation	NNW-SSE
Trench revealed on ditch, one pit and a posthole. Consists of ploughsoil and subsoil overlying natural geology.						Length (m)	30
						Width (m)	2
						Avg. depth (m)	
Context No.	Type	Fill Of	Width (m)	Depth (m)	Description	Finds	Date
13800	Layer			0.33	Ploughsoil. Dark brownish grey sandy clay ploughsoil		
13801	Layer			0.32	Subsoil. Dark greyish brown sandy clay		
13802	Layer				Natural. Mid brownish orange sandy clay		
13803	Cut		0.82	0.18	Ditch. NE-SW		
13804	Fill	13803			Primary Fill. Light brownish grey sandy silt		
13805	Cut		0.6	0.25	Pit		
13806	Fill	13805	0.6	0.25	Primary Fill. Light brownish grey sandy clay		
13807	Cut		0.22	0.11	Posthole		
13808	Fill	13807	0.22	0.11	Deliberate Backfill. Dark grey clayey silt	Pot	Prehist
13809	Unexcavated feature		0.51		Pit. Light brownish grey sandy clay		
13810	Unexcavated feature		0.94		Pit. Light brownish grey sandy clay.		
13811	Cut		0.87	0.32	Ditch. E-W		

13812	Fill	13811	0.87	0.32	Primary Fill. Light brownish grey sandy clay.		
13813	Cut		0.78	0.24	Pit		
13814	Fill	13813	0.78	0.24	Primary Fill. Light brownish grey sandy silt		
Trench 139							
General description					Orientation	NE-SW	
Trench devoid of archaeology. Consists of ploughsoil and subsoil overlying natural geology of silty clay.					Length (m)	30	
					Width (m)	2	
					Avg. depth (m)	0.66	
Context No.	Type	Fill Of	Width (m)	Depth (m)	Description	Finds	Date
13900	Layer			0.27	Ploughsoil. Dark brown grey ploughsoil		
13901	Layer			0.39	Subsoil. Mid brown grey silty-clay		
13902	Layer				Natural. Mid grey orange silty clay		
13903	Cut		0.65	0.04	Natural Feature		
Trench 140							
General description					Orientation		
					Length (m)		
					Width (m)		
					Avg. depth (m)		
Context No.	Type	Fill Of	Width (m)	Depth (m)	Description	Finds	Date
Trench 141							
General description					Orientation		
					Length (m)		
					Width (m)		
					Avg. depth (m)		
Context No.	Type	Fill Of	Width (m)	Depth (m)	Description	Finds	Date
Trench 142							
General description					Orientation	NE-SW	
Trench devoid of archaeology. Consists of ploughsoil and subsoil overlying natural geology of silty clay with gravel patches.					Length (m)	30	
					Width (m)	1.8	
					Avg. depth (m)	0.44	
Context No.	Type	Fill Of	Width (m)	Depth (m)	Description	Finds	Date
14200	Layer			0.32	Ploughsoil. Dark greyish brown sandy silt, friable with occasional sub-		

					angular flint fragments and rounded pebbles.		
14201	Layer			0.12	Subsoil. Mid yellowish brown sandy clay with rare rounded pebbles.		
14202	Layer				Natural. Mid brownish orange sandy clay with gravel inclusion.		

Trench 143

General description					Orientation	WSW-ENE
Trench devoid of archaeology. Consists of ploughsoil and subsoil overlaying natural geology of sandy clay with gravel patches.					Length (m)	30
					Width (m)	1.8
					Avg. depth (m)	0.44

Context No.	Type	Fill Of	Width (m)	Depth (m)	Description	Finds	Date
14300	Layer			0.3	Ploughsoil. Dark greyish brown sandy silt, friable with occasional sub-angular flint fragments and rounded pebbles.		
14301	Layer			0.14	Subsoil. Mid yellowish brown sandy clay with rare rounded pebbles.		
14302	Layer				Natural. Mid brownish orange sandy clay with occasional patches of gravel and manganese inclusion.		

Trench 144

General description					Orientation	N-S
Trench devoid of archaeology. Consists of ploughsoil and subsoil overlaying natural geology of sandy clay with frequent gravel patches.					Length (m)	30
					Width (m)	2.1
					Avg. depth (m)	0.5

Context No.	Type	Fill Of	Width (m)	Depth (m)	Description	Finds	Date
14400	Layer		2.1		Ploughsoil. Mid grey brown silty sand, friable		
14401	Layer		2.1	0.07	Subsoil. Mid greyish orange silty clay, friable		
14402	Layer		2.1		Natural. Mid yellowish orange sandy clay with patches of gravel and geological bands of grey sand with		

					manganese and hematite inclusion.		
Trench 145							
General description					Orientation	W-E	
Trench devoid of archaeology. Consists of ploughsoil and subsoil overlying natural geology of sandy clay and gravel					Length (m)	30	
					Width (m)	2	
					Avg. depth (m)	0.39	
Context No.	Type	Fill Of	Width (m)	Depth (m)	Description	Finds	Date
14500	Layer			0.28	Ploughsoil. Dark greyish brown sandy silt, friable with occasional sub-angular flint fragments and rounded pebbles.		
14501	Layer			0.11	Subsoil. Mid yellowish brown sandy clay with rare rounded pebbles.		
14502	Layer				Natural. Mid brownish orange sandy clay with gravel inclusion and geological bands of grey sand.		
Trench 146							
General description					Orientation	N-S	
Trench devoid of archaeology. Consists of ploughsoil and subsoil overlying natural geology of sandy clay and gravel.					Length (m)	30	
					Width (m)	2	
					Avg. depth (m)	0.5	
Context No.	Type	Fill Of	Width (m)	Depth (m)	Description	Finds	Date
14600	Layer			0.4	Ploughsoil. Dark greyish brown sandy silt, friable with occasional sub-angular flint fragments and rounded pebbles.		
14601	Layer			0.08	Subsoil. Mid yellowish brown sandy clay with rare rounded pebbles.		
14602	Layer				Natural. Mid brownish orange sandy clay with gravel inclusion and geological bands of grey sand.		
Trench 147							
General description					Orientation	NW-SE	
					Length (m)	30	

Trench devoid of archaeology. Only single tree-throw was investigated in the trench. Consists ploughsoil and subsoil overlying natural geology of sandy clay with gravel inclusion.						Width (m)	2.1
						Avg. depth (m)	0.55
Context No.	Type	Fill Of	Width (m)	Depth (m)	Description	Finds	Date
14700	Layer			0.35	Ploughsoil. Mid greyish brown sandy silt with occasional small rounded pebbles.		
14701	Layer			0.15	Subsoil. Mid yellowish brown sandy clay, no inclusion visible.		
14702	Layer				Natural. Mid yellowish orange silty clay with gravel patches, friable		
14703	Cut			0.22	Tree-throw. Mid greyish brown silty sand.		

Trench 148

General description						Orientation	N-S
Trench devoid of archaeology. Consists of ploughsoil and subsoil overlying natural geology of sandy clay and gravel						Length (m)	30
						Width (m)	2
						Avg. depth (m)	0.6
Context No.	Type	Fill Of	Width (m)	Depth (m)	Description	Finds	Date
14800	Layer				Ploughsoil. Dark greyish brown sandy silt, friable with occasional sub-angular flint fragments and rounded pebbles.		

Trench 149

General description						Orientation	NE-SW
Trench devoid of archaeology. Consists of ploughsoil and subsoil overlying natural geology of sandy clay with some patches of gravel.						Length (m)	30
						Width (m)	2
						Avg. depth (m)	0.41
Context No.	Type	Fill Of	Width (m)	Depth (m)	Description	Finds	Date
14900	Layer			0.29	Ploughsoil. Dark greyish brown sandy silt, friable with occasional sub-angular flint fragments and rounded pebbles.		
14901	Layer			0.13	Subsoil. Mid yellowish brown sandy clay with rare rounded pebbles.		

14902	Layer				Natural. Mid brownish orange sandy clay with patches of gravel.		
Trench 150							
General description					Orientation	NW- SE	
Consists of ploughsoil and subsoil overlaying natural geology of sandy clay.					Length (m)	30	
					Width (m)	2.1	
					Avg. depth (m)	0.58	
Context No.	Type	Fill Of	Width (m)	Depth (m)	Description	Finds	Date
15000	Layer		2.1	0.35	Ploughsoil. Dark greyish brown silty clay with occasional rounded pebbles.		
15001	Layer		2.1	0.15	Subsoil. Mid yellowish brown sandy clay with occasional pebbles inclusion.		
15002	Layer		2.1		Natural. Mid yellowish orange sandy clay with gravel inclusion.		
15003	Cut		1.14	0.43	Ditch. N-S oriented ditch. No finds. Relationship with 15005 not visible		
15004	Fill	15003	1.14	0.43	Primary Fill. Mid greyish brown silty clay		
15005	Cut		0.4	0.29	Ditch. Southern end of N-S oriented ditch.		
15006	Fill	15005	0.4	0.29	Primary Fill. Mid greyish brown silty clay		
Trench 151							
General description					Orientation	W-E	
Trench revealed single ditch. Consists of ploughsoil overlying natural geology of sandy clay.					Length (m)	30	
					Width (m)	2	
					Avg. depth (m)	0.36	
Context No.	Type	Fill Of	Width (m)	Depth (m)	Description	Finds	Date
15100	Layer			0.36	Ploughsoil. Dark greyish brown sandy silt, friable with occasional sub-angular flint fragments and rounded pebbles.		
15101	Layer			0.08	Subsoil. Mid orangey brown clayey sand		

15102	Layer				Other Layer. Very dark brown silty sand		
15103	Layer				Natural. Mid greyish orange silty clay with gravel inclusions		
15104	Cut		1.4	0.33	Ditch. Linear ditch oriented E-W		
15105	Fill	15104	1.4	0.33	Secondary Fill. Mid brownish grey silty sand	Pot	c 1200-1350?

Trench 152

General description					Orientation	N-S	
Consists of ploughsoil and subsoil overlying natural geology of sandy clay.					Length (m)	30	
					Width (m)	2	
					Avg. depth (m)	0.6	
Context No.	Type	Fill Of	Width (m)	Depth (m)	Description	Finds	Date
15200	Layer			0.3	Ploughsoil. Dark greyish brown sandy silt, friable with occasional sub-angular flint fragments and rounded pebbles.		
15201	Layer			0.16	Subsoil. Mid yellowish brown sandy clay with rare rounded pebbles.		
15202	Layer				Natural. Mid brownish orange sandy clay with gravel inclusion.		
15203	Cut		0.6	0.25	Natural Feature. Treebole, sampled		
15204	Fill	15203	60	0.25	Primary Fill. Dark greyish brown, mottled silty clay.		

Trench 153

General description					Orientation	NNW-SSE	
Trench devoid of archaeology. Consists of ploughsoil overlaying natural geology of clayey sand with gravel inclusion and bands of grey sand with manganese and hematite fragments.					Length (m)	30	
					Width (m)	1.8	
					Avg. depth (m)	0.33	
Context No.	Type	Fill Of	Width (m)	Depth (m)	Description	Finds	Date
15300	Layer			0.35	Ploughsoil. Dark greyish brown sandy silt, friable with occasional sub-angular flint fragments and rounded pebbles.		
15301	Layer				Natural. Mid yellowish orange clayey sand with		

					gravel inclusion and geological bands of grey sand with manganese and hematite fragments.		
Trench 154							
General description					Orientation	E-W	
Trench devoid of archaeology. Consists of ploughsoil and subsoil overlying the natural geology of clayey sand.					Length (m)	30	
					Width (m)	2	
					Avg. depth (m)	0.53	
Context No.	Type	Fill Of	Width (m)	Depth (m)	Description	Finds	Date
15400	Layer			0.32	Ploughsoil. Dark greyish brown sandy silt, friable with rare rounded pebbles.		
15401	Layer			0.23	Subsoil. Mid yellowish brown sandy clay, no inclusion visible.		
15402	Layer				Natural. Mid yellowish orange clayey sand with gravel inclusion.		
Trench 155							
General description					Orientation	ENE-WSW	
Trench revealed one ditch at WSW corner. Consists of ploughsoil and subsoil overlying natural geology of clayey sand with occasional gravel inclusion.					Length (m)	30	
					Width (m)	1.8	
					Avg. depth (m)	0.45	
Context No.	Type	Fill Of	Width (m)	Depth (m)	Description	Finds	Date
15500	Layer			0.3	Ploughsoil. Dark greyish brown sandy silt, friable with occasional sub-angular flint fragments and rounded pebbles.		
15501	Layer			0.15	Subsoil. Mid yellowish brown sandy clay with rare rounded pebbles.		
15502	Layer				Natural. Mid yellowish orange clayey sand with occasional gravel and manganese inclusions.		
15503	Cut		0.9	0.32	Ditch. Linear concave base sloping sides		
15504	Fill	15503	0.9	0.32	Other Fill. Mid grey brown silty sand. Common manganese		

Trench 156							
General description					Orientation	W-E	
Trench revealed one ditch. Consists of ploughsoil and subsoil overlying natural clayey sand with gravel					Length (m)	30	
					Width (m)	2	
					Avg. depth (m)	0.62	
Context No.	Type	Fill Of	Width (m)	Depth (m)	Description	Finds	Date
15600	Layer			0.4	Ploughsoil. Dark brownish grey sandy silt with rare rounded pebbles.		
15601	Layer			0.12	Subsoil. Mid yellowish brown sandy clay, no inclusion visible.		
15602	Layer				Natural. Mid yellowish and brownish orange clayey sand with gravel inclusion.		
15603	Cut		2.01	0.3	Ditch. Ditch continues in Trench 158. N/S orientation.		
15604	Fill	15603	2.01	0.3	Secondary Fill. Dark orangeish brown, clayey sand	Animal bone	
Trench 157							
General description					Orientation	NNW-SSE	
Trench devoid of archaeology. Consists of ploughsoil overlaying natural geology of clayey sand with occasional gravel inclusion.					Length (m)	30	
					Width (m)	2	
					Avg. depth (m)	0.3	
Context No.	Type	Fill Of	Width (m)	Depth (m)	Description	Finds	Date
15700	Layer			0.3	Ploughsoil. Dark greyish brown sandy silt, friable with occasional sub-angular flint fragments and rounded pebbles.		
15701	Layer				Natural. Mid brownish and yellowish orange clayey sand with occasional gravel and manganese inclusions.		
Trench 158							
General description					Orientation	ENE-WSW	
					Length (m)	30	

Trench revealed one ditch. Trench devoid of archaeology. Consists of ploughsoil and subsoil overlaying natural geology of clayey sand with gravel patches.						Width (m)	1.8
						Avg. depth (m)	0.46
Context No.	Type	Fill Of	Width (m)	Depth (m)	Description	Finds	Date
15800	Layer			0.3	Ploughsoil. Dark greyish brown sandy silt, friable with occasional sub-angular flint fragments and rounded pebbles.		
15801	Layer				Subsoil. Mid yellowish brown sandy clay with rare rounded pebbles.		
15802	Layer			0.16	Natural. Mid yellowish orange clayey sand with occasional gravel and manganese inclusions.		
15803	Void						
15804	Cut		1.56	0.28	Ditch. Linear u shaped sloping base. continues in 156		
15805	Fill			0.28	Secondary Fill. Secondary fill of ditch mid grey brown sandy silt		

Trench 159

General description						Orientation	ENE-WSW
Trench revealed one ditch. Consists of ploughsoil and subsoil overlaying natural geology of clayey sand with gravel patches.						Length (m)	30
						Width (m)	2
						Avg. depth (m)	0.44
Context No.	Type	Fill Of	Width (m)	Depth (m)	Description	Finds	Date
15900	Layer			0.3	Ploughsoil. Dark greyish brown sandy silt, friable with occasional sub-angular flint fragments and rounded pebbles.		
15901	Layer			0.14	Subsoil. Mid yellowish brown sandy clay		
15902	Layer				Natural. Mid yellowish and reddish orange clayey sand, gravel inclusions.		
15903	Cut		1.3	0.32	Ditch. Linear Concave base and sides		

15904	Fill	15903	1.3	0.32	Other Fill. Mid grey yellow silty sand	Animal bone	
Trench 160							
General description					Orientation	NNW-SSE	
Trench devoid of archaeology. Consists of ploughsoil and subsoil overlaying natural geology of clayey sand with frequent patches of gravel and grey silty sand.					Length (m)	30	
					Width (m)	2	
					Avg. depth (m)	0.52	
Context No.	Type	Fill Of	Width (m)	Depth (m)	Description	Finds	Date
16000	Layer			0.3	Ploughsoil. Dark greyish brown sandy silt, friable with occasional sub-angular flint fragments and rounded pebbles.		
16001	Layer			0.22	Subsoil. Mid yellowish brown sandy clay with rare rounded pebbles.	Flint flake	
16002	Layer				Natural. Mid yellowish orange clayey sand with frequent patches of gravel.		
Trench 161							
General description					Orientation	NNW-SSE	
A curvilinear gully, turning from ENE to NW was noted towards the SSE edge of the trench. Trench consists in ploughsoil overlying natural geology of sandy clay.					Length (m)	30	
					Width (m)	2	
					Avg. depth (m)	0.38	
Context No.	Type	Fill Of	Width (m)	Depth (m)	Description	Finds	Date
16100	Layer			0.35	Ploughsoil. Dark greyish brown sandy silt, friable with occasional sub-angular flint fragments and rounded pebbles.		
16101	Layer				Natural. Mid brownish orange sandy clay with occasional patches of gravel and manganese inclusion.		
16102	Cut		0.72	0.3	Ditch. Cut of curvilinear gully running from ENE towards NW.		
16103	Fill	16102	0.72	0.3	Secondary Fill. Single fill of curvilinear gully. Mid grey brown, silty sand, friable to	Pot, burnt flint	IA

					moderate. Frequent charcoal flecks, occasional pottery sherds and CBM. Occasional S-M size rounded stones.		
16104	Cut		0.44	0.08	Natural Feature. Natural change in the geology.		
16105	Cut		1.14	0.1	Natural Feature. Natural change in the geology		
16106	Cut		0.16	0.08	Posthole. Posthole next NE L.O.E of trench. Photos# 1443-4 Sub circular-gradual break of slope, moderate concave sides, flat base.		
16107	Fill	16106	0.16	0.08	Primary Fill. Single fill of posthole. Mid greyish brown silty sand. Friable		
16108	Cut		0.3	0.17	Posthole. Circular steep sides concave base		
16109	Cut		0.14	0.14	Stakehole. Sub circular concave base vertical sides		
16110	Fill	16109	0.14	0.14	Other Fill. Dark black brown silty sand		
16111	Cut		2.1	0.54	Ditch or natural feature. Linear feature steep sides uneven base NE-SW. Note: feature was not surveyed and therefore does not appear on plan		
16112	Fill	16111	0.9	0.22	Secondary Fill. Light grey white Sandy clay		
16113	Fill	16111	2.2	0.54	Secondary Fill. Mid red brown, sandy clay, abundant iron oxide		
16114	Fill	16108	0.33	0.17	Secondary Fill. Mid brown sandy clay		

Trench 162

General description					Orientation	ENE-WSW	
Trench devoid of archaeology. Consists of ploughsoil overlying subsoil which is deeper at ENE end and overlies natural geology of sandy clay.					Length (m)	30	
					Width (m)	2	
					Avg. depth (m)	0.44	
Context No.	Type	Fill Of	Width (m)	Depth (m)	Description	Finds	Date

16200	Layer			0.3	Ploughsoil. Dark greyish brown sandy silt, friable with occasional sub-angular flint fragments and rounded pebbles.		
16201	Layer			0.13	Subsoil. Mid yellowish brown sandy clay with rare rounded pebbles.		
16202	Layer				Natural. Head deposit. Mid brownish orange sandy clay with moderate gravel patches.		
16203	Cut				Natural Feature		
16204	Void						
16205	Layer		2	0.1	Natural. Light grey sandy clay		
16206	Layer		1	0.1	Natural. Light brownish grey sandy clay abundant manganese		
16207	Unexcavated feature		2		Ditch. Mid orange grey clayey sand		

Trench 163

General description

Orientation

NNE-SSW

Trench revealed single large ditch running NNW-SSE at the centre of the trench. Consists of ploughsoil overlying natural geology of sandy clay with gravel inclusion and bands of grey sand with manganese and hematite fragments.

Length (m)

30

Width (m)

2

Avg. depth (m)

0.3

Context No.	Type	Fill Of	Width (m)	Depth (m)	Description	Finds	Date
16300	Layer			0.3	Ploughsoil. Dark greyish brown sandy silt, friable with occasional sub-angular flint fragments and rounded pebbles.		
16301	Layer				Natural. Head deposit. Mid brownish orange sandy clay with occasional gravel inclusion and bands of grey sand with manganese and hematite flecks.		
16302	Cut		1.48	0.46	Ditch		
16303	Fill	16302		0.46	Secondary Fill. Mid brownish grey sandy clay, friable with occasional hematite and chalk flecks.		

Trench 164							
General description					Orientation		NNW-SSE
Trench devoid of archaeology. Consists of ploughsoil overlying subsoil and natural geology of sandy clay with gravel inclusion and bands of grey and yellow silty sand.					Length (m)		30
					Width (m)		2
					Avg. depth (m)		0.4
Context No.	Type	Fill Of	Width (m)	Depth (m)	Description	Finds	Date
16400	Layer			0.3	Ploughsoil. Dark greyish brown sandy silt, friable with occasional sub-angular flint fragments and rounded pebbles.		
16401	Layer			0.1	Subsoil. Mid yellowish brown sandy clay with rare rounded pebbles.		
16402	Layer				Natural. Head deposit. Mid brownish orange sandy clay with occasional patches of gravel.		
Trench 165							
General description					Orientation		NNE-SSW
Trench devoid of archaeology. Consists of ploughsoil and subsoil overlying natural geology of sandy clay with gravel inclusion.					Length (m)		30
					Width (m)		2
					Avg. depth (m)		0.35
Context No.	Type	Fill Of	Width (m)	Depth (m)	Description	Finds	Date
16500	Layer			0.3	Ploughsoil. Dark greyish brown sandy silt, friable with occasional sub-angular flint fragments and rounded pebbles.		
16501	Layer			0.03	Subsoil. Mid brown grey sandy clay. Inconsistent across length of trench		
16502	Layer				Natural. Head deposit. Mid brownish orange sandy clay with gravel inclusion and geological bands of grey sand with manganese fragments.		
Trench 166							
General description					Orientation		WSW-ENE

Trench revealed one small ditch running NNW-SSE at WSW end of trench. Consists of ploughsoil overlaying natural geology of sandy clay with gravel inclusions.						Length (m)	30
						Width (m)	2
						Avg. depth (m)	0.3
Context No.	Type	Fill Of	Width (m)	Depth (m)	Description	Finds	Date
16600	Layer			0.3	Ploughsoil. Dark greyish brown sandy silt, friable with occasional sub-angular flint fragments and rounded pebbles.		
16601	Layer				Natural. Head deposit. Mid brownish orange sandy clay with moderate gravel inclusion and occasional bands of grey sand with manganese and hematite flecks.		
16602	Cut				Ditch		
16603	Fill	16602	0.6	0.27	Secondary Fill. Light orangey grey silty sand, friable with occasional oxide iron inclusions.		

Trench 167

General description						Orientation	NW-SE
Trench devoid of archaeology. Consists of ploughsoil overlying subsoil and natural geology of sandy clay with frequent gravel patches.						Length (m)	30
						Width (m)	2
						Avg. depth (m)	0.3
Context No.	Type	Fill Of	Width (m)	Depth (m)	Description	Finds	Date
16700	Layer			0.25	Ploughsoil. Dark greyish brown sandy silt, friable with occasional sub-angular flint fragments and rounded pebbles.		
16701	Layer			0.05	Subsoil. Mid brownish grey silty clay with rare rounded pebbles.		
16702	Layer				Natural. Head deposit. Mid reddish brown sandy clay with frequent patches of gravel.		

Trench 168

General description						Orientation	NE-SW
						Length (m)	28

Trench devoid of archaeology. Consists of ploughsoil and subsoil overlying natural geology of sandy clay and gravel.						Width (m)	2
						Avg. depth (m)	0.49
Context No.	Type	Fill Of	Width (m)	Depth (m)	Description	Finds	Date
16800	Layer			0.28	Ploughsoil. Dark brownish grey sandy silt.		
16801	Layer			0.19	Subsoil. Mid reddish brown silty clay		
16802	Layer				Natural. Light yellowish reddish brown sandy clay.		
Trench 169							
General description						Orientation	SE-NW
Trench devoid of archaeology. Consists of ploughsoil overlying the natural geology of sandy clay.						Length (m)	25
						Width (m)	2
						Avg. depth (m)	0.32
Context No.	Type	Fill Of	Width (m)	Depth (m)	Description	Finds	Date
16900	Layer			0.31	Ploughsoil. Dark brownish grey sandy silt		
16901	Layer				Natural. Light yellowish brown sandy clay with gravels.		
Trench 170							
General description						Orientation	N-S
Trench devoid of archaeology. Consists of ploughsoil and subsoil overlying the natural geology of sandy clay.						Length (m)	30
						Width (m)	2
						Avg. depth (m)	0.65
Context No.	Type	Fill Of	Width (m)	Depth (m)	Description	Finds	Date
17000	Layer			0.34	Ploughsoil. Dark greyish brown, sandy silt		
17001	Layer			0.31	Subsoil. Mid reddish brown, sandy clay		
17002	Layer				Natural. Mid brownish red, sandy clay		
Trench 171							
General description						Orientation	E-W
Trench devoid of archaeology. Consists of ploughsoil and subsoil overlying the natural geology of sandy clay.						Length (m)	30
						Width (m)	2
						Avg. depth (m)	0.5
Context No.	Type	Fill Of	Width (m)	Depth (m)	Description	Finds	Date
17100	Layer			0.34	Ploughsoil. Dark greyish brown, sandy silt		

17101	Layer			0.16	Subsoil. Mid reddish brown, silty clay		
17102	Layer				Natural. Light greyish red, sandy clay		
Trench 172							
General description					Orientation	NE-SW	
Trench devoid of archaeology. Trench consists of ploughsoil and subsoil overlying the natural geology of sandy clay.					Length (m)	30	
					Width (m)	2	
					Avg. depth (m)	0.6	
Context No.	Type	Fill Of	Width (m)	Depth (m)	Description	Finds	Date
17200	Layer			0.41	Ploughsoil. Dark greyish brown, sandy silt		
17201	Layer			0.2	Subsoil. Mid reddish brown, silty clay		
17202	Layer				Natural. Mid brownish red, sandy clay		
Trench 173							
General description					Orientation	E-W	
Trench devoid of archaeology. Consists of ploughsoil and subsoil overlying the natural geology of sandy clay.					Length (m)	30	
					Width (m)	2	
					Avg. depth (m)	0.6	
Context No.	Type	Fill Of	Width (m)	Depth (m)	Description	Finds	Date
17300	Layer			0.32	Ploughsoil. Dark greyish brown, sandy silt		
17301	Layer			0.26	Subsoil. Light reddish brown, silty clay		
17302	Layer				Natural. Mid brownish red, sandy clay with gravels		
Trench 174							
General description					Orientation	NE-SW	
Trench devoid of archaeology. Consists of ploughsoil and subsoil overlying natural geology of sandy clay.					Length (m)	30	
					Width (m)	2	
					Avg. depth (m)	0.5	
Context No.	Type	Fill Of	Width (m)	Depth (m)	Description	Finds	Date
17400	Layer			0.35	Ploughsoil. Dark greyish brown silty clay.		
17401	Layer			0.18	Subsoil. Mid reddish brown silty clay.		
17402	Layer				Natural. Light yellowish red sandy clay.		
Trench 175							

General description						Orientation	SE-NW
Trench devoid of archaeology. Consists of ploughsoil and subsoil overlying natural geology of sandy clay.						Length (m)	30
						Width (m)	2
						Avg. depth (m)	0.52
Context No.	Type	Fill Of	Width (m)	Depth (m)	Description	Finds	Date
17500	Layer			0.35	Ploughsoil. Dark greyish brown silty clay		
17501	Layer			0.2	Subsoil. Mid reddish brown silty clay		
17502	Layer				Natural. Mid reddish brown sandy clay		
Trench 176							
General description						Orientation	N-S
Trench revealed one ditch. Consists of ploughsoil and subsoil overlying the natural geology of sandy clay.						Length (m)	30
						Width (m)	2
						Avg. depth (m)	0.42
Context No.	Type	Fill Of	Width (m)	Depth (m)	Description	Finds	Date
17600	Layer			0.3	Ploughsoil. Dark grey clayey silty ploughsoil		
17601	Layer			0.1	Subsoil. mid reddish brown clayey silt subsoil.		
17602	Layer				Natural. Mid brownish red sandy clay		
17603	Cut		0.52	0.05	Ditch. NE-SW shallow ditch.		
17604	Fill	17603	0.52	0.05	Primary Fill. Soft mid greyish brown sandy silt		
Trench 177							
General description						Orientation	NE-SW
Trench devoid of archaeology. Trench consists of ploughsoil and subsoil overlying a sandy clay natural.						Length (m)	30
						Width (m)	2
						Avg. depth (m)	0.43
Context No.	Type	Fill Of	Width (m)	Depth (m)	Description	Finds	Date
17700	Layer			0.31	Ploughsoil. Dark greyish brown, sandy silt		
17701	Layer			0.12	Subsoil. Mid reddish brown, sandy silt		
17702	Layer				Natural. Mid greyish red, sandy clay with gravels		
Trench 178							
General description						Orientation	N-S
						Length (m)	30

Trench devoid of archaeology. Consists of ploughsoil and subsoil overlying the natural geology of sandy clay.						Width (m)	2
						Avg. depth (m)	0.53
Context No.	Type	Fill Of	Width (m)	Depth (m)	Description	Finds	Date
17800	Layer			0.37	Ploughsoil. Soft, dark greyish brown, sandy silt		
17801	Layer			0.16	Subsoil. Mid reddish brown, sandy clay		
17802	Layer				Natural. Mid greyish red, sandy clay		
Trench 179							
General description						Orientation	E-W
Trench devoid of archaeology. Trench consists of ploughsoil and subsoil overlying the natural geology of sandy clay.						Length (m)	30
						Width (m)	2
						Avg. depth (m)	0.48
Context No.	Type	Fill Of	Width (m)	Depth (m)	Description	Finds	Date
17900	Layer			0.32	Ploughsoil. Dark greyish brown, sandy silt		
17901	Layer			0.16	Subsoil. Mid reddish brown, sandy silt		
17902	Layer				Natural. Light greyish red, sandy clay with gravels.		
17903	Cut		0.9	0.26	Natural Feature. Natural pit? Light orangeish grey soft silty sand		
Trench 180							
General description						Orientation	E-W
Trench revealed one ditch. Trench consists of ploughsoil and subsoil overlying the natural geology of sandy clay.						Length (m)	30
						Width (m)	2
						Avg. depth (m)	0.4
Context No.	Type	Fill Of	Width (m)	Depth (m)	Description	Finds	Date
18000	Layer			0.26	Ploughsoil. Soft dark greyish brown, sandy silt		
18001	Layer			0.22	Subsoil. Firm mid reddish brown, sandy clay.		
18002	Layer		2		Natural. Firm mid greyish red, sandy silt.		
18003	Cut		0.67	0.19	Ditch		
18004	Fill	18003	0.4	0.09	Primary Fill. Firm, light yellowish grey, composed of sandy-silt. Fill included		

					occasional small subangular stones		
18005	Fill	18003	0.67	0.1	Secondary Fill. Loose, mid brownish grey, composed of sandy silt. Fill produced occasional fine charcoal flecks and occasional small subangular stones.		

Trench 181

General description					Orientation	NNW-SSE	
Trench devoid of archaeology. Trench consists of ploughsoil and subsoil overlying the natural geology of sandy clay.					Length (m)	30	
					Width (m)	2	
					Avg. depth (m)	0.56	
Context No.	Type	Fill Of	Width (m)	Depth (m)	Description	Finds	Date
18100	Layer			0.39	Ploughsoil. Dark greyish brown, sandy silt		
18101	Layer			0.17	Subsoil. Mid reddish brown, silty sand		
18102	Layer				Natural. Mid Greyish brown, sandy clay, interspersed with patches of silty sand		

Trench 182

General description					Orientation	N-S	
Trench devoid of archaeology. Consists of ploughsoil and subsoil overlying the natural geology of sandy clay.					Length (m)	30	
					Width (m)	2	
					Avg. depth (m)	0.45	
Context No.	Type	Fill Of	Width (m)	Depth (m)	Description	Finds	Date
18200	Layer		2	0.26	Ploughsoil. Dark greyish brown, sandy silt		
18201	Layer		2	0.17	Subsoil. Mid reddish brown, silty clay		
18202	Layer		2		Natural. Mid reddish brown sandy clay		
18203	Void						
18204	Cut		0.34	0.21	Natural Feature. Natural feature with rare stones		

Trench 183

General description					Orientation	NE-SW
Trench revealed one ditch. Trench consists of ploughsoil and subsoil overlying the natural geology of sandy clay.					Length (m)	30
					Width (m)	2
					Avg. depth (m)	0.7

Context No.	Type	Fill Of	Width (m)	Depth (m)	Description	Finds	Date
18300	Layer		2	0.5	Ploughsoil. Soft dark brownish grey, sandy silt.		
18301	Layer		2	0.27	Subsoil. Firm mid reddish brown sandy clay.		
18302	Void						
18303	Void						
18304	Layer		2		Natural. Mid reddish brown sandy clay, with patches of light yellowish brown gravelly sand.		
18305	Cut		1.04	0.39	Ditch		
18306	Fill	18305			Primary Fill. Mid greyish brown, sandy silt. Rare charcoal.	Pot	MBA-IA

Trench 184

General description

Trench revealed five ditches and one pit. Trench consists of ploughsoil and subsoil overlying the natural geology of sandy clay. Trench extended to allow deeper excavation by hand below 1m.

Orientation

N-S

Length (m)

30

Width (m)

2

Avg. depth (m)

0.8

Context No.	Type	Fill Of	Width (m)	Depth (m)	Description	Finds	Date
18400	Layer			0.58	Ploughsoil. Dark greyish brown, sandy silt		
18401	Layer			0.32	Subsoil. Mid reddish brown sandy clay		
18402	Void						
18403	Void						
18404	Layer		2		Natural. Light reddish brown, sandy clay		
18405	Cut		0.64	0.15	Ditch		
18406	Fill	18405	0.64	0.15	Primary Fill. Light brownish grey silty clay		
18407	Cut		0.7	0.13	Ditch		
18408	Fill	18407	0.7	0.13	Other Fill. Mid reddish brown sandy clay		
18409	Cut		0.65	0.3	Pit		
18410	Fill	18409	0.65	0.2	Primary Fill. Light greyish brown clayey silt.		
18411	Cut		0.6	0.2	Ditch		
18412	Fill	18411	0.6	0.2	Other Fill. Mid reddish brown sandy clay fill, occasional charcoal		
18413	Cut		1.82	0.48	Ditch		

18414	Fill	18413	1.8	0.26	Secondary Fill. Mid brown grey silty clay		
18415	Fill	18413		0.26	Primary Fill. Mid blueish grey sandy clay.		
18416	Cut		0.7	0.28	Ditch		
18417	Fill	18416	0.7	0.28	Primary Fill. Mid brownish grey sandy clay.	Pot	MIA
18418	Unexcavated feature				Ditch		

Trench 185

General description					Orientation	NE-SW
Trench revealed two large dark pits and a field several field trains cutting the pits. Consists of ploughsoil overlying natural geology of sand and gravel.					Length (m)	30
					Width (m)	2
					Avg. depth (m)	0.4

Context No.	Type	Fill Of	Width (m)	Depth (m)	Description	Finds	Date
18500	Layer			0.4	Ploughsoil. Dark greyish brown, silty sand		
18501	Layer				Natural. Mixture of light greyish and orangey brown, sand and gravel		
18502	Cut		0.79	0.38	Pit		
18503	Fill	18502	0.79	0.38	Primary Fill. Dark grey brown, silty sand. Charcoal rich.		
18504	Cut		0.41	0.37	Pit		
18505	Fill	18504	0.41	0.37	Primary Fill. Dark grey brown, silty sand. Charcoal rich.	Pot	c 1050-1225?
18506	Cut		1.19	0.37	Pit		
18507	Fill	18506	1.19	0.37	Primary Fill. Mid grey brown, silty sand. Inclusions of CBM.		
18508	Cut				Pit		
18509	Fill				Secondary Fill	Pot	c 1000-1225?
18510	Cut				Pit		
18511	Fill	18510	1.6	0.7	Secondary Fill. Light grey brown with orange mottling, silty clay	Pot	c 1000-1225?
18512	Cut		1.2	0.6	Pit		
18513	Fill	18512	1.2	0.6	Secondary Fill. Dark brown orange, silty clay	Pot	c 970-1100?
18514	Unexcavated feature		0.54		Ditch. Field drain or ditch cutting through pits running NW-SE		
18515	Void						

18516	Cut			0.80	Pit. Duplicate number		
18517	Fill	18516		0.36	Deliberate Backfill. Slightly blue greyish brown gravelly clayey sand	Animal bone	
18518	Fill	18516		0.60	Deliberate Backfill. Mid greyish brown/orange mottled silty clay	Pot	c 1000-1225?
18519	Cut			0.40	Pit. Duplicate number for 18508		
18520	Fill	18519		0.40	Secondary Fill. Mid yellowish brown clayey silt		
18521	Fill	18519		0.18	Secondary Fill. Dark greyish brown clayey silt	Slag	

Trench 186

General description

Trench revealed two possible pits. Consists of ploughsoil and subsoil overlying natural geology of sand and gravel, with sandy clay at northern end.

Orientation	N-S
Length (m)	30
Width (m)	2
Avg. depth (m)	0.47

Context No.	Type	Fill Of	Width (m)	Depth (m)	Description	Finds	Date
18600	Layer			0.35	Ploughsoil. Dark greyish brown, silty sand.		
18601	Layer			0.12	Subsoil. Light orangey grey, sand		
18602	Layer				Natural. Mid orangey brown, sandy clay at northern end to light orangey brown sand and gravel towards the south.		
18603	Cut		0.67	0.16	Tree-throw		
18604	Fill	18603	0.67	0.16	Primary Fill. Mid orange grey. Silty sand.		
18605	Void						
18606	Void						
18607	Cut		0.38	0.08	Natural Feature. Tree bowl.		

Trench 187

General description

Trench revealed three ditches. Consists of ploughsoil and subsoil overlying natural geology of sand and gravel.

Orientation	E-W
Length (m)	30
Width (m)	2
Avg. depth (m)	0.45

Context No.	Type	Fill Of	Width (m)	Depth (m)	Description	Finds	Date
-------------	------	---------	-----------	-----------	-------------	-------	------

18700	Layer			0.25	Ploughsoil. Dark greyish brown, silty sand		
18701	Layer			0.2	Subsoil. Light greyish brown, silty sand		
18702	Layer				Natural. Light orangey brown sand and gravel		
18703	Layer			0.2	Subsoil		
18704	Cut		1.76	0.2	Ditch. Field drain which runs through ditch has been excavated also and slot is overcut		
18705	Fill	18704	1.76	0.2	Other Fill		
18706	Cut			0.2	Ditch		
18707	Fill	18706		0.2	Primary Fill. Mottled grey and blue, yellow silty sand.		
18708	Cut		1.20	0.30	Ditch		
18709	Fill		1.20	0.30	Primary Fill. Light bluish grey silty clay.		

Trench 188

General description	Orientation	N-S
Trench contains one ditch running N-S. Trench consists of a silty clay gravelled natural. Overlain by a silty clay ploughsoil	Length (m)	30
	Width (m)	2.1
	Avg. depth (m)	0.4

Context No.	Type	Fill Of	Width (m)	Depth (m)	Description	Finds	Date
18800	Layer		2.1	0.4	Ploughsoil. Mid grey brown, silty clay, friable		
18801	Layer		2.1		Natural. Mid yellow orange silty clay with gravel throughout		
18802	Cut		1.1	0.4	Ditch		
18803	Fill	18802	1.1	0.4	Primary Fill. Mid reddish black, silty sand.		

Trench 189

General description	Orientation	NE-SW
Trench devoid of archaeology. Trench consists of silty clay ploughsoil, overlaying a gravelled natural	Length (m)	30
	Width (m)	2
	Avg. depth (m)	0.41

Context No.	Type	Fill Of	Width (m)	Depth (m)	Description	Finds	Date
18900	Layer				Ploughsoil. mid grey brown, silty clay, friable		

Trench 190

General description						Orientation	N-S
Northern end of trench contains possible enclosure ditch with E-W alignment, and a tree-throw exists in the middle of trench. Trench consists of gravelled natural overlain by a silty clay topsoil						Length (m)	30
						Width (m)	2.1
						Avg. depth (m)	0.3
Context No.	Type	Fill Of	Width (m)	Depth (m)	Description	Finds	Date
19000	Layer		2.1	0.3	Ploughsoil. Mid grey brown, silty clay, friable		
19001	Layer		2.1		Natural. Mid yellow orange, silty clay with gravel throughout		
19002	Cut		1.07	0.12	Natural Feature. Tree-throw		
19003	Cut		1	0.36	Ditch. Probable cut of ditch		
19004	Fill	19003	1	0.36	Secondary Fill. Fill of ditch. Mid blueish grey clay.		
Trench 191							
General description						Orientation	NE-SW
Trench contains one modern hedgerow and rooting. Trench consists of silty gravelled natural overlain by silty clay topsoil						Length (m)	30
						Width (m)	2.1
						Avg. depth (m)	0.35
Context No.	Type	Fill Of	Width (m)	Depth (m)	Description	Finds	Date
19100	Layer		2.1	0.35	Ploughsoil. Mid grey brown, silty clay, friable		
19101	Layer		2.1		Natural. Mid yellow brown, silty sand, friable		
19102	Cut		0.95	0.45	Ditch		
19103	Fill	19102	0.95	0.45	Primary Fill. Mid brown grey. Silty sand.		
Trench 192							
General description						Orientation	N-S
Trench devoid of archaeology. Silty gravelled natural overlain by silt clay ploughsoil						Length (m)	30
						Width (m)	2.1
						Avg. depth (m)	0.36
Context No.	Type	Fill Of	Width (m)	Depth (m)	Description	Finds	Date
19200	Layer				Ploughsoil. Mid grey brown, silty clay		
19201	Layer				Natural. Mid yellow orange, silty sand, friable		
Trench 193							
General description						Orientation	NW-SE

Trench contains two NW-SE running ditches. Trench consists of silty clay natural overlain by a silty clay ploughsoil						Length (m)	30
						Width (m)	2.1
						Avg. depth (m)	0.32
Context No.	Type	Fill Of	Width (m)	Depth (m)	Description	Finds	Date
19300	Layer		2.1	0.32	Ploughsoil. Mid grey brown silty clay, friable		
19301	Layer		2.1		Natural. Mid orangey brown, silty clay, friable		
19302	Cut		1.9	0.33	Plough Furrow. Linear running N-S		
19303	Fill	19302	1.9	0.33	Secondary Fill. Mid yellow brown, sandy clay		
19304	Cut		2.1	0.46	Ditch		
19305	Fill	19304	2.1	0.46	Other Fill		
19306	Cut				Pit		
19307	Fill				Secondary Fill		
Trench 194							
General description						Orientation	N-S
Trench devoid of archaeology. Trench consists of patchy gravelled natural overlain by ploughsoil						Length (m)	30
						Width (m)	2.1
						Avg. depth (m)	0.33
Context No.	Type	Fill Of	Width (m)	Depth (m)	Description	Finds	Date
19400	Layer		2	0.3	Ploughsoil. Mid grey brown clayey silt friable		
19401	Layer		2	0.13	Natural. Mid brownish yellow silty clay soft		
19402	Void						
Trench 195							
General description						Orientation	E-W
Trench revealed several treebole holes that were investigated, but none contained archaeological evidence. Trench contains a mottled natural overlain by subsoil and ploughsoil.						Length (m)	30
						Width (m)	2.1
						Avg. depth (m)	0.43
Context No.	Type	Fill Of	Width (m)	Depth (m)	Description	Finds	Date
19500	Layer		2.1	0.34	Ploughsoil. Mid grey brown, silty clay, friable		
19501	Layer		2.1	0.1	Subsoil. Mid orangey brown, silty clay, friable		
19502	Layer		2.1		Natural. Mottled light yellowish white silt with mid orange brown, friable		

Trench 196							
General description						Orientation	NW-SE
Trench contained one ditch. Trench consists of silty clay gravelled natural overlain by ploughsoil						Length (m)	30
						Width (m)	2.1
						Avg. depth (m)	0.27
Context No.	Type	Fill Of	Width (m)	Depth (m)	Description	Finds	Date
19600	Layer		2.1	0.24	Ploughsoil. Mid grey brown, silty clay, friable		
19601	Layer		2.1		Natural. Mid orangey yellow with greyish white patches, silty clay with gravel throughout		
19602	Cut		1.63	0.49	Ditch		
19603	Fill	19602			Primary Fill. Mid reddish grey silty clay.		
19604	Fill	19602			Secondary Fill. Light reddish grey silty clay.	Burnt flint	
19605	Fill	19602			Tertiary Fill. Light greyish brown silty clay.	Pot	1275-1350
Trench 197							
General description						Orientation	E-W
Trench devoid of archaeology. Trench contains a silty clay natural with gravel patches, overlain by ploughsoil						Length (m)	30
						Width (m)	2.1
						Avg. depth (m)	0.32
Context No.	Type	Fill Of	Width (m)	Depth (m)	Description	Finds	Date
19700	Layer		2.1	0.3	Ploughsoil. Mid grey brown, silty clay, friable		
19701	Layer		2.1		Natural. Mid yellowish brown silty clay with light yellow white patches		
Trench 198							
General description						Orientation	N-S
Trench devoid of archaeology. Consists of a silty clay covered by a subsoil and ploughsoil						Length (m)	30
						Width (m)	2.1
						Avg. depth (m)	0.43
Context No.	Type	Fill Of	Width (m)	Depth (m)	Description	Finds	Date
19800	Layer		2.1	0.34	Ploughsoil. Light grey brown, silty clay, friable		

19801	Layer		2.1	0.09	Subsoil. Mid grey orange, silty clay, friable		
19802	Layer		2.1		Natural. Mid yellowish orange silty clay, friable		
Trench 199							
General description						Orientation	NNE-SSW
Trench consists of ploughsoil and subsoil overlying a sandy clay natural. Trench revealed one pit, one gully, one ditch and a natural feature.						Length (m)	30
						Width (m)	1.8
						Avg. depth (m)	0.5
Context No.	Type	Fill Of	Width (m)	Depth (m)	Description	Finds	Date
19900	Layer		1.8	0.3	Ploughsoil. Dark brownish black, silty clay.	Flint flake	
19901	Layer		1.8	0.2	Subsoil. Mid orange brown, silty sandy clay.		
19902	Layer		1.8		Natural. Mid yellowish orange, sandy clay, patches of gravel		
19903	Cut		0.98	0.23	Pit		
19904	Fill	19903	0.98	0.23	Primary Fill. Mid brownish grey, silty clay		
19905	Cut		0.62	0.06	Ditch		
19906	Fill	19905	0.62	0.06	Primary Fill. Light yellowish brown, silty clay.		
19907	Cut		0.47	0.19	Ditch		
19908	Fill	19907	0.47	0.19	Primary Fill. Med orange brown, silty clay.		
19909	Layer		1.56		Natural. Natural feature		
Trench 200							
General description						Orientation	N-S
Trench consists of ploughsoil and subsoil overlying a silty clay natural. Trench revealed three pits and two ditches.						Length (m)	30
						Width (m)	1.8
						Avg. depth (m)	0.7
Context No.	Type	Fill Of	Width (m)	Depth (m)	Description	Finds	Date
20000	Layer		1.8	0.4	Ploughsoil. Dark brown/grey clayey silt.		
20001	Layer		1.8	0.3	Subsoil. Mid brownish grey, silty clay		

20002	Layer		1.8		Natural. Mid reddish brown, silty clay with patches gravel		
20003	Cut		1.02	0.21	Pit		
20004	Fill	20003	1.02	0.21	Primary Fill. Med orange brown, silty clay.		
20005	Cut		0.32	0.15	Ditch		
20006	Fill	20005	0.32	0.15	Primary Fill. Med orange brown, silty clay.		
20007	Cut		0.43	0.11	Ditch		
20008	Fill	20007	0.43	0.11	Primary Fill. Med yellowish brown, silty clay.		
20009	Cut		1.02	0.3	Pit		
20010	Fill	20009	1.02	0.3	Primary Fill. Med yellowish brown, silty clay		
20011	Cut		0.48	0.1	Pit		
20012	Fill	20011	0.48	0.1	Primary Fill. Med greyish brown, silty clay.		

Trench 201

General description	Orientation	N-S
Trench consists of ploughsoil overlying a sandy clay natural. Trench revealed one pit, two linear, one terminating and one natural feature	Length (m)	30
	Width (m)	1.8
	Avg. depth (m)	0.45

Context No.	Type	Fill Of	Width (m)	Depth (m)	Description	Finds	Date
20100	Layer		1.8	0.29	Ploughsoil. Dark brownish grey clayey silt		
20101	Layer		1.8		Natural. Mid reddish brown sandy clay		
20102	Cut		0.59	0.13	Ditch		
20103	Fill	20102	0.59	0.13	Primary Fill. Mid greyish brown sandy clay		
20104	Cut		0.3	0.04	Natural Feature. Animal burrow		
20105	Cut		1.2	0.61	Ditch		
20106	Fill	20105	1.2	0.61	Primary Fill. Light greyish brown sandy clay		
20107	Cut		1.85	0.61	Pit		
20108	Fill	20107	1.85	0.61	Primary Fill. Mid grey/brown sandy clay		

Trench 202

General description	Orientation	E-W
---------------------	-------------	-----

Trench revealed one ditch and one natural hollow. Consists of topsoil and subsoil overlying a sandy clay natural.						Length (m)	30
						Width (m)	1.8
						Avg. depth (m)	0.42
Context No.	Type	Fill Of	Width (m)	Depth (m)	Description	Finds	Date
20200	Layer		1.8	0.32	Ploughsoil. Dark grey clayey silt		
20201	Layer		1.8	0.08	Subsoil. Mid yellowish brown sandy clay		
20202	Layer		1.8		Natural. Mid reddish brown sandy clay		
20203	Unexcavated feature		2.72		Natural Feature. Irregular ovular pit. Dark greyish brown soft sandy silt with very frequent medium rounded stone inclusions.	Flint flake	
20204	Cut		0.64	0.22	Ditch		
20205	Fill	20204	0.64	0.22	Primary Fill. Mid greyish brown sandy clay.	Flint flakes and scrapers	

Trench 203

General description						Orientation	E-W
Trench consists of ploughsoil overlying subsoil all over a sandy clay natural. Trench revealed two natural features and a tree-throw which contained worked flint.						Length (m)	30
						Width (m)	1.8
						Avg. depth (m)	0.44
Context No.	Type	Fill Of	Width (m)	Depth (m)	Description	Finds	Date
20300	Layer		1.8	0.29	Ploughsoil. Dark grey clayey silt		
20301	Layer		1.8	0.11	Subsoil. Dark yellowish brown clayey silt		
20302	Layer		1.8		Natural. Mid reddish brown sandy clay		
20303	Cut		0.55	0.2	Natural Feature. Irregular natural feature. Light brownish grey soft sandy silt.		
20304	Cut		2.59	0.79	Tree-throw		
20305	Cut		0.47	0.14	Natural Feature. Irregular natural pit. Light brownish grey sandy silt	Worked flint, Fired clay	Late Neo/EBA
20306	Fill	20304	1.33	0.26	Primary Fill. Mid brownish compact grey sandy silt	Worked flint. Pot	EBA; Prehist?
20307	Fill	20304	0.92	0.19	Secondary Fill. Light whiteish grey soft sandy silt		

20308	Fill	20304	2.59	0.35	Secondary Fill. Soft mid brownish grey sandy silt	Worked flint, flint rubber	Late Neo/EBA
Trench 204							
General description					Orientation	NNW-SSE	
Trench consists of ploughsoil and subsoil overlying sandy clay natural. Trench revealed one ditch and one natural feature.					Length (m)	30	
					Width (m)	1.8	
					Avg. depth (m)	0.5	
Context No.	Type	Fill Of	Width (m)	Depth (m)	Description	Finds	Date
20400	Layer		1.8	0.3	Ploughsoil. Dark brown silty clay		
20401	Layer		1.8	0.2	Subsoil. Orangey brown silty clay		
20402	Layer		1.8		Natural. Orangey brown silty clay		
20403	Cut		1.32	0.51	Ditch		
20404	Fill	20403	1.32	0.51	Primary Fill. Orangey silty clay	Pot	Prehist? Or E/M Saxon
20405	Fill	20403	1.32	0.51	Secondary Fill. Light brown sandy clay		
20406	Cut		0.42	0.21	Natural Feature. Natural feature possibly made by a tree presented a light brown sandy clay		
Trench 205							
General description					Orientation	NNE-SSW	
Trench consists of ploughsoil and subsoil overlying sandy clay natural. Trench revealed two pits.					Length (m)	30	
					Width (m)	1.8	
					Avg. depth (m)	0.63	
Context No.	Type	Fill Of	Width (m)	Depth (m)	Description	Finds	Date
20500	Layer		1.8	0.24	Ploughsoil. Dark greyish brown clayey silt		
20501	Layer		1.8	0.4	Subsoil. Mid greyish brown mottled sandy clay		
20502	Layer		1.8		Natural. Mid orangish brown sandy clay		
20503	Cut		0.9	0.14	Pit		
20504	Fill	20503	0.9	0.14	Primary Fill. Light grey sandy clay		
20505	Cut		0.65	0.44	Pit		
20506	Fill	20505	0.65	0.44	Primary Fill. Moderate, mottled mid orange-grey, sandy silt		

Trench 206							
General description					Orientation	E-W	
Trench consists of ploughsoil and subsoil overlying a sandy clay natural. Trench revealed one ditch and one posthole.					Length (m)	30	
					Width (m)	1.8	
					Avg. depth (m)	0.42	
Context No.	Type	Fill Of	Width (m)	Depth (m)	Description	Finds	Date
20600	Layer		1.8	0.33	Ploughsoil. Mid greyish-brown, silty topsoil		
20601	Layer		1.8	0.09	Subsoil. Light greyish-brown, silty clay		
20602	Layer		1.8		Natural. Light yellowish orange, sandy clay		
20603	Cut		0.83	0.52	Ditch		
20604	Fill	20603	0.83	0.52	Primary Fill. Loose, mottled light brownish-grey, sandy clay.		
20605	Cut		0.34	0.09	Posthole		
20606	Fill	20605	0.34	0.09	Primary Fill. Loose, light orangish-brown, sandy clay		
Trench 207							
General description					Orientation	N-S	
Trench consists of ploughsoil and subsoil overlying a sandy clay natural. Trench revealed one elongated pit and three natural features.					Length (m)	30	
					Width (m)	1.8	
					Avg. depth (m)	0.62	
Context No.	Type	Fill Of	Width (m)	Depth (m)	Description	Finds	Date
20700	Layer		1.8	0.33	Ploughsoil. Dark grey brown clayey silt		
20701	Layer		1.8	0.21	Subsoil. Mid brown silty clay		
20702	Layer		1.8		Natural. Light orange brown sand		
20703	Cut		1.39	0.22	Natural Feature. Tree-throw, dark grey brown silty clay.		
20704	Cut		1.08	0.08	Natural Feature. Tree-throw, dark grey brown silty clay.		
20705	Cut		1.02	0.26	Natural Feature. Irregular oval, Dark grey brown silty clay.		
20706	Cut		0.91	0.28	Pit		
20707	Fill	20706	0.91	0.28	Primary Fill. Dark grey brown silty clay		
Trench 208							
General description					Orientation	E-W	

Trench consists of ploughsoil and subsoil overlying a sandy clay natural. Trench revealed one gully, two ditches and one natural feature.						Length (m)	30
						Width (m)	1.8
						Avg. depth (m)	0.45
Context No.	Type	Fill Of	Width (m)	Depth (m)	Description	Finds	Date
20800	Layer		1.8	0.3	Topsoil. Mid greyish brown, silty ploughsoil		
20801	Layer		1.8	0.15	Subsoil. Light greyish brown, silty clay		
20802	Layer		1.8		Natural. Light greyish yellow, sandy clay.		
20803	Cut		1.26	0.4	Ditch		
20804	Fill	20803	1.26	0.4	Primary Fill. Moderate, mottled light brownish-grey, clayey silt		
20805	Cut		0.41	0.13	Ditch		
20806	Fill	20805	0.41	0.13	Primary Fill. Loose, mottled light brownish-grey, clayey silt		
20807	Cut		1.38	0.29	Ditch		
20808	Fill	20807	1.38	0.29	Primary Fill. Medium brownish grey, clayey silt		
20809	Cut				Natural Feature. Likely a tree bowl or natural silty deposit		
20810	Unexcavated feature				Ditch. Recorded by Surveyor		

Trench 209

General description						Orientation	N-S
Trench consists of ploughsoil and subsoil over a sandy clay natural. Trench revealed two ditches.						Length (m)	30
						Width (m)	1.8
						Avg. depth (m)	0.55
Context No.	Type	Fill Of	Width (m)	Depth (m)	Description	Finds	Date
20900	Layer		1.8	0.3	Ploughsoil. Dark brown/grey clayey silt.	Flint flake	
20901	Layer		1.8	0.25	Subsoil. Medium brown/grey clayey silt.		
20902	Layer		1.8		Natural. Pale yellow/grey sandy clay.		
20903	Cut		0.57	0.21	Ditch		
20904	Fill	20903	0.57	0.21	Primary Fill. Light grey sandy clay		
20905	Cut		1.05	0.12	Ditch		
20906	Fill	20905	1.05	0.12	Primary Fill. Light grey mottled sandy clay		

Trench 210							
General description					Orientation	NW-SE	
Trench consists of ploughsoil and subsoil overlying a clayey sand natural. Trench revealed three linear features.					Length (m)	30	
					Width (m)	1.8	
					Avg. depth (m)	0.6	
Context No.	Type	Fill Of	Width (m)	Depth (m)	Description	Finds	Date
21000	Layer		1.8	0.3	Ploughsoil. Dark greyish brown, silty clay		
21001	Layer		1.8	0.3	Subsoil. Med brownish orange, silty clay		
21002	Layer		1.8		Natural. Med orange yellow, sandy clay, gravel patches		
21003	Cut		0.64	0.24	Ditch		
21004	Fill	21003	0.64	0.24	Primary Fill. Med greyish brown, silty clay.		
21005	Cut		0.82	0.21	Ditch		
21006	Fill	21005	0.82	0.21	Primary Fill. Soft dark greyish brown sandy silt	Pot	MBA-IA
21007	Cut		0.83	0.18	Ditch		
21008	Fill	21007	0.82	0.18	Primary Fill. Med greyish brown, silty clay		
Trench 211							
General description					Orientation	NW-SE	
Trench consists of ploughsoil and subsoil overlying a sandy clay natural. Trench revealed 3 linear features one of which was unexcavated. It has been excavated in two other trenches.					Length (m)	30	
					Width (m)	1.8	
					Avg. depth (m)	0.57	
Context No.	Type	Fill Of	Width (m)	Depth (m)	Description	Finds	Date
21100	Layer		1.8	0.33	Ploughsoil. Dark greyish brown clayey silt		
21101	Layer		1.8	0.2	Subsoil. Mid orange brown sandy clay		
21102	Layer		1.8		Natural. Mid orange brown sandy clay		
21103	Cut		0.43	0.05	Ring Gully		
21104	Fill	21103	0.43	0.05	Primary Fill. Light mottled brownish grey		
21105	Cut		1.47	0.62	Ditch. Modern		
21106	Fill	21105	1.47	0.62	Primary Fill. Firm dark blueish grey clayey silt		

21107	Unexcavated feature		1.66		Ditch. N-S. Dark reddish grey clayey silt		
Trench 212							
General description					Orientation	E-W	
Trench consists of ploughsoil overlying a clayey sand natural. Trench revealed two natural features, one pit and five linears.					Length (m)	30	
					Width (m)	1.8	
					Avg. depth (m)	0.55	
Context No.	Type	Fill Of	Width (m)	Depth (m)	Description	Finds	Date
21200	Layer		1.8	0.55	Ploughsoil. Dark grey clayey silt		
21201	Layer		1.8		Natural. Mid reddish brown sandy clay		
21202	Cut		0.46	0.32	Ditch. NW-SE		
21203	Fill	21202	0.46	0.32	Primary Fill. Firm dark reddish brown clayey silt	CBM	M15-17C
21204	Cut		0.34	0.27	Ditch. NW-SE		
21205	Fill	21204	0.34	0.27	Primary Fill. Firm dark reddish grey clayey silt		
21206	Cut		1.15	0.17	Ditch. NW-SE		
21207	Fill	21206	1.15	0.17	Primary Fill. Firm mid brownish grey clayey silt		
21208	Cut		2.07	0.42	Ditch. N-S		
21209	Fill	21208	2.07	0.42	Primary Fill. Firm mid blueish grey with red mottling clayey silt		
21210	Cut		1.28	0.34	Ditch		
21211	Fill	21210	1.28	0.34	Primary Fill. Dark greyish brown mod compact clayey silt		
21212	Cut		0.79	0.59	Natural Feature. Natural feature. Soft light whiteish grey with brown mottling. Sandy silt.		
21213	Cut		0.82	0.06	Natural Feature. Natural feature. Mid blueish grey with brown mottling. Soft sandy silt.		
21214	Cut		1.40	0.45	Pit		
21215	Fill	21214	1.40	0.45	Primary Fill. Soft mid brownish grey sandy silt	Pot	AD 200-400
Trench 213							
General description					Orientation	N-S	
Trench consists of ploughsoil overlying a sandy clay natural. Trench revealed a pond and two natural pits.					Length (m)	30	
					Width (m)	1.8	

						Avg. depth (m)	0.38
Context No.	Type	Fill Of	Width (m)	Depth (m)	Description	Finds	Date
21300	Layer		1.8	0.35	Ploughsoil. Dark grey clayey silt		
21301	Layer		1.8		Natural. Mid reddish brown sandy clay		
21302	Cut		12.38	1.45	Pond. Machine sondage to the base.		
21303	Fill	21302		0.45	Secondary Fill. Soft mid greyish brown sandy silt		
21304	Fill	21302		0.25	Secondary Fill. Soft mid brownish grey sandy silt	CBM	LC15-C17
21305	Cut		2.71	0.45	Pit. Pit altered by bioturbation.		
21306	Cut		0.28	0.08	Pit		
21307	Fill	21306	0.28	0.08	Primary Fill. Soft mod brownish grey sandy silt		
21308	Fill	21305	2.71	0.45	Primary Fill. Soft dark brownish grey sandy silt	Flint	
21309	Fill	21302			Primary Fill. Mid grey/brown clayey silt.		

Trench 214

General description	Orientation	NW-SE
Trench consists of ploughsoil and subsoil overlying a sandy clay natural. Trench contained one NE-SW linear, and one large tree-throw.	Length (m)	30
	Width (m)	1.8
	Avg. depth (m)	0.64

Context No.	Type	Fill Of	Width (m)	Depth (m)	Description	Finds	Date
21400	Layer		1.8	0.3	Ploughsoil. Mid grey brown friable silty clay	Flint axe	
21401	Layer		1.8	0.34	Subsoil. Mid brown silty sand friable		
21402	Layer		1.8		Natural. Mid yellow brown sand		
21403	Cut		0.93	0.17	Ditch		
21404	Fill	21403	0.93	0.17	Primary Fill. Mid greyish brown soft silty sand		
21405	Cut		2.26	0.78	Tree-throw. Not fully bottomed.		
21406	Fill	21405	1.96	0.3	Primary Fill. Light yellow brown mottled silt.		
21407	Fill	21405	1.34	0.36	Secondary Fill. Mid grey mottled friable silty fill	Pot	MBA-IA

21408	Fill	21405	1.86	0.14	Tertiary Fill. Mid grey brown friable silty clay.		
Trench 215							
General description					Orientation	N-S	
Trench consists of ploughsoil and subsoil over a sandy clay natural. Trench revealed three natural features.					Length (m)	30	
					Width (m)	1.8	
					Avg. depth (m)	0.56	
Context No.	Type	Fill Of	Width (m)	Depth (m)	Description	Finds	Date
21500	Layer		1.8	0.3	Ploughsoil. Dark grey brown clayey silt		
21501	Layer		1.8	0.26	Subsoil. Mid brown clay		
21502	Layer		1.8		Natural. Mid yellowish-reddish brown clay		
21503	Cut		0.6	0.19	Natural Feature. Treebowl, light grey with brown and red mottling, friable silty clay, irregular boomerang shape		
21504	Cut		0.53	0.15	Natural Feature. Round discrete, natural feature, light grey with red and brown mottling, friable silty clay		
21505	Cut		0.44	0.06	Natural Feature. Oval discrete natural feature, mid grey with reddish mottling friable silty clay		
Trench 216							
General description					Orientation	E-W	
Trench consists of ploughsoil and subsoil over a sandy clay natural. Trench contained one gully, a tree-throw, three pits, a ditch and two field drains.					Length (m)	30	
					Width (m)	1.8	
					Avg. depth (m)	0.45	
Context No.	Type	Fill Of	Width (m)	Depth (m)	Description	Finds	Date
21600	Layer		1.8	0.31	Topsoil. Mid greyish brown sandy silt		
21601	Layer		1.8	0.12	Subsoil. Light yellow brown clay silt		
21602	Layer		1.8		Natural. Mid yellow brown sandy clay		
21603	Cut		1.4	0.11	Tree-throw		
21604	Fill	21603	1.4	0.11	Primary Fill. Mid greyish yellow sandy silt		
21605	Cut		0.32	0.1	Ditch		

21606	Fill	21605	0.32	0.1	Primary Fill. Light brownish grey clay silt		
21607	Cut		2	0.2	Pit		
21608	Fill	21607	2	0.2	Primary Fill. Mid greyish brown clayish silt		
21609	Cut		1	0.53	Pit. Same as 21610		
21610	Cut		1	0.53	Pit. Same as 21609		
21611	Fill	21610	1	0.23	Primary Fill. Dark grey brown silty clay	CBM	L15-EC17?
21612	Fill	21610	1	0.3	Secondary Fill. Mid grey brown silty clay	Pot	AD 43-410
21613	Cut		1	0.41	Ditch. N-S		
21614	Fill	21613	1	0.3	Primary Fill. Light-mid grey brown silty clay	Pot	AD 1-150
21615	Fill	21613	1	0.1	Primary Fill. Mod yellow brown silty clay		

Trench 217

General description		Orientation	NE-SW
Trench consists of ploughsoil and subsoil overlying a sandy clay natural. Trench revealed one modern feature, one NE-SW linear and one pit.		Length (m)	30
		Width (m)	1.8
		Avg. depth (m)	0.55

Context No.	Type	Fill Of	Width (m)	Depth (m)	Description	Finds	Date
21700	Layer		1.8	0.32	Ploughsoil. Friable dark grey brown clayey silt.		
21701	Layer		1.8	0.23	Subsoil. Mid brown silty clay		
21702	Layer		1.8		Natural. Mid/light orange brown clay.		
21703	Cut		0.3	0.21	Modern. Modern feature, light blueish grey silty clay.		
21704	Cut		1.29	0.25	Ditch		
21705	Fill	21704	1.29	0.25	Primary Fill. Friable mid grey-brown silty clay	Flint blade	
21706	Cut		1.43	0.36	Pit		
21707	Fill	21706	1.43	0.13	Primary Fill. Firm light blue grey silty clay.	Pot	AD 200-400
21708	Fill	21706	1.43	0.2	Secondary Fill. Friable, mottled light grey blue/light yellow brown silty clay.		

Trench 218

General description		Orientation	N-S
Trench consists of ploughsoil and subsoil overlying a clayey sand natural. Trench revealed three pits and a posthole.		Length (m)	30
		Width (m)	1.8

						Avg. depth (m)	0.54
Context No.	Type	Fill Of	Width (m)	Depth (m)	Description	Finds	Date
21800	Layer		1.8	0.3	Ploughsoil. Dark grey clayey silt	Flint flake	
21801	Layer		1.8	0.24	Subsoil. Mid reddish brown clayey silt		
21802	Layer		1.8		Natural. Mid reddish brown clayey sand		
21803	Cut		1.51	0.46	Pit		
21804	Fill	21803	1.51	0.46	Primary Fill. Light yellowish brown firm sandy silt		
21805	Cut		1.68	0.37	Pit		
21806	Fill	21805	1.61	0.37	Primary Fill. Soft dark greyish brown sandy silt	Flint flake	
21807	Cut		0.46	0.22	Posthole		
21808	Fill	21807	0.46	0.22	Primary Fill. Soft dark greyish brown sandy silt		
21809	Cut		0.31	0.16	Pit		
21810	Fill	21809	0.31	0.16	Primary Fill. Soft light greyish brown sandy silt.		

Trench 219

General description

Trench consists of ploughsoil and subsoil overlying a sandy clay natural. Trench contained one pit, three ditches and four tree-throws.

Orientation

NW-SE

Length (m)

30

Width (m)

1.8

Avg. depth (m)

0.38

Context No.	Type	Fill Of	Width (m)	Depth (m)	Description	Finds	Date
21900	Layer		1.8	0.26	Ploughsoil. Mid brown sandy clay	Pot	c 1875-1925
21901	Layer		1.8	0.12	Subsoil. Mid brownish orange sandy clay		
21902	Layer		1.8		Natural. Light orange silty clay		
21903	Cut		0.7	0.09	Pit. NE-SW		
21904	Fill	21903	0.7	0.09	Primary Fill. Brown orange silty clay		
21905	Cut		0.95	0.37	Ditch. E-W		
21906	Fill	21905	0.95	0.37	Primary Fill. Light greyish brown silty clay	Pot, CBM	c 1100-1350; LC15-C17
21907	Cut		1	0.26	Natural Feature. Tree-bowl, uneven base, mid grey brown fill, some black mottling, friable silt		
21908	Cut		0.93	0.2	Ditch		

21909	Fill	21908	0.93	0.2	Primary Fill. Mid greyish brown silty clay	Pot, Lava frags	c 1000-1225?
21910	Cut		0.37	0.1	Tree-throw		
21911	Fill	21910	0.37	0.1	Primary Fill. Mid greyish brown mottled clayey silt		
21912	Cut		2	0.25	Natural Feature. Boxed intervention determined that silty area was a large tree bowl, so not fully excavated as natural feature. No break of slope seen as continues past LOE, and not fully excavated, but the base is very irregular and undulating. Mid grey brown fill but mottled with yellow and grey. Friable silty clay.		
21913	Cut		1.6	0.55	Ditch. E-W		
21914	Fill	21913	1.6	0.55	Primary Fill. Mid grey brown and yellow brown sandy clay	Pot, animal bone	c 1000-1225?
21915	Cut		0.57	0.11	Tree-throw. Tree-throw truncating 21913, not present in section		
21916	Fill		0.57	0.11	Primary Fill. Mid greyish brown sandy clay		

Trench 220

General description	Orientation	N-S
Trench consists of ploughsoil and subsoil overlying a sandy clay natural. Trench revealed three pits, one posthole and six linear features.	Length (m)	30
	Width (m)	1.8
	Avg. depth (m)	0.58

Context No.	Type	Fill Of	Width (m)	Depth (m)	Description	Finds	Date
22000	Layer		1.8	0.32	Ploughsoil. Firm dark grey brown clayey silt		
22001	Layer		1.8	0.26	Subsoil. Mid brown silty clay		
22002	Layer		1.8		Natural. Light yellow brown sandy clay		
22003	Cut		0.68	0.14	Pit		
22004	Fill	22003	0.68	0.14	Primary Fill. Mottled mid blue/grey light orange brown clayey silt		
22005	Cut		0.63	0.17	Ditch		

22006	Fill	22005	0.63	0.17	Primary Fill. Firm, mixed blueish grey/orange brown silty clay.		
22007	Cut		0.39	0.12	Ditch. Very heavily disturbed by rooting and burrowing action.		
22008	Fill	22007	0.39	0.12	Tertiary Fill. Moderately friable, mid blueish grey silty clay.	Burnt flint	
22009	Fill	22007	0.49	0.27	Primary Fill. Firm light yellow brown silty clay.		
22010	Cut		1.16	0.34	Ditch		
22011	Fill	22010	1.16	0.34	Primary Fill. Firm light blue grey silty clay.	CBM, animal bone, burnt flint	Post-medieval
22012	Cut		0.26	0.09	Posthole		
22013	Fill	22012	0.26	0.09	Post-pad. Firm light blue grey silty clay.		
22014	Cut		1.21	0.53	Pit		
22015	Fill	22014	1.21	0.22	Primary Fill. Firm mid reddish brownish grey silty clay	Pot, burnt flint	LBA/EIA
22016	Fill	22014	0.72	0.1	Deliberate Backfill. Soft dark grey sandy silt	Pot, burnt flint	LBA-IA
22017	Fill	22014	0.82	0.14	Secondary Fill. Firm mid greyish brown clayey silt	Pot, burnt flint	LBA
22018	Cut		1.41	0.52	Ditch. NW-SE		
22019	Fill	22018	0.83	0.49	Primary Fill. Soft light whiteish grey sandy silt		
22020	Fill	22018	1.41	0.52	Secondary Fill. Firm dark greyish brown clayey silt	Pot, CBM (Tegula), animal bone, burnt flint	c 1000-1225; Roman
22021	Cut		0.69	0.31	Ditch. E-W		
22022	Fill	22021	0.69	0.31	Primary Fill. Firm dark yellowish grey clayey silt		
22023	Cut		0.31	0.23	Ditch		
22024	Fill	22023	0.31	0.23	Primary Fill. Firm dark yellowish grey sandy silt	CBM, burnt flint	MC15-C17
22025	Cut		0.65	0.53	Pit		
22026	Fill	22025	0.65	0.53	Primary Fill. Firm dark grey clayey silt	Pot, animal bone,	c 1000-1225

						burnt flint	
22027	Fill	22010	0.34	0.12	Secondary Fill. Moderately friable dark blue grey silty clay.		

Trench 221

General description

Trench consists of ploughsoil overlying a sandy clay natural. Trench contains one NW-SE gully and six unexcavated linears, five of which were excavated in Trench 222. The remainder have been excavated in two other trenches.

Orientation

E-W

Length (m)

30

Width (m)

1.8

Avg. depth (m)

0.5

Context No.	Type	Fill Of	Width (m)	Depth (m)	Description	Finds	Date
22100	Layer		1.8	0.5	Ploughsoil. Mid grey brown silty clay friable		
22101	Layer		1.8		Natural. Mid reddish yellow brown firm clay		
22102	Cut		0.35	0.07	Ditch		
22103	Fill	22102	0.35	0.07	Primary Fill. Mid grey friable silty clay		
22104	Unexcavated feature		0.4		Ditch. Unexcavated ditch, mid grey silty clay, friable, cut by gully 22102		
22105	Unexcavated feature		1		Ditch. Unexcavated ditch, mid grey friable silty clay, cuts gully 22102		

Trench 222

General description

Trench consists of ploughsoil and subsoil overlying a sandy clay natural. Trench revealed six linears running N-S, one of which was left unexcavated as it has been excavated in two other trenches.

Orientation

E-W

Length (m)

30

Width (m)

1.8

Avg. depth (m)

0.55

Context No.	Type	Fill Of	Width (m)	Depth (m)	Description	Finds	Date
22200	Layer		1.8	0.34	Ploughsoil. Dark grey clayey silt		
22201	Layer		1.8	0.21	Subsoil. Dark greyish brown clayey silt		
22202	Layer		1.8		Natural. Mid reddish brown sandy clay		
22203	Cut		0.75	0.3	Ditch. N-S 1252-4		
22204	Fill	22203	0.75	0.3	Primary Fill. Firm mid brownish grey clayey silt	Animal bone	
22205	Cut		0.52	0.24	Pit		
22206	Fill	22205	0.52	0.24	Primary Fill. Firm mid greenish brown clayey silt		
22207	Cut		0.84	0.26	Ditch. N-S		

22208	Fill	22207	0.84	0.26	Primary Fill. Firm mid blueish grey clayey silt	Burnt flint, animal bone	
22209	Unexcavated feature		3.12		Ditch. Modern Ditch N-S. Excavated in Tr221. Dark grey clayey silt		
22210	Cut		0.6	0.15	Ditch. N-S		
22211	Fill	22210	0.6	0.15	Primary Fill. Firm dark grey clayey silt		
22212	Cut		0.37	0.13	Ditch. N-S		
22213	Fill	22212	0.37	0.13	Primary Fill. Firm dark reddish grey clayey silt		

B.1 Prehistoric Pottery

By Alex Davies

Introduction

B.1.1 Some 165 sherds of prehistoric pottery weighing 1178g were recovered, as well as substantial remains of two further pots (contexts 6602 and 9705) that were block lifted and have not been quantified (Table 1). A large proportion of the present sherd count derives from a third vessel in context 6607 (54 sherds, 780g). Overall, prehistoric pottery was found in 33 contexts over 26 trenches.

B.1.2 Pottery from each context was scanned with spot-dates given based on the latest material present. Fabrics were recorded in order of their approximate frequency in any one context. The two most common inclusion types were noted, using the following fabric codes:

- Fl Flint
- Qs Quartz sand
- Qg Glauconitic sand (can contain quartz sand)
- Sh Shell (voids; not certainly present)
- Ve Vegetal (probably grass/chaff)

B.1.3 The grade of the fabric was also recorded with a number suffix, ranging from 1 (fine) to 4 (very coarse).

Neolithic

B.1.4 Three contexts produced Neolithic pottery. Middle Neolithic Peterborough Ware was found in contexts 2105 and 11203. Pottery spot-dated to the early or middle Neolithic was found in context 11401. Context 2105 produced a single abraded rim sherd. The upper part of the rim is present and is incurving. Decoration is just visible below the rim, appearing to show a bird bone impression. The rim is too abraded for the sherd to be placed to one of the Peterborough Ware subdivisions. The Peterborough Ware sherd in 11203 is a body sherd and has very abraded decoration over the entire sherd. The sherd in context 11401 is not decorated, but it is very small. All of this material is in poorly sorted flint fabrics.

Late Neolithic or early Bronze Age

B.1.5 A single context, 18306, produced a single highly abraded grog-tempered base sherd. It is likely this dates to the late Neolithic or early Bronze Age, although the context also produced flint tempered material that is likely to be middle Bronze Age to Iron Age. The grog-tempered sherd is therefore probably residual. All of the late Neolithic pottery at Mucking was grog-tempered, while none of the middle Bronze Age or Iron Age pottery contained grog (Birley 2016; Brown 2016; Brudenell 2016a). Less than 1% of the late Bronze Age material solely contained grog (Brudenell 2016b, 160).

Middle Bronze Age

- B.1.6 Context 6607 is confidently dated to the middle Bronze Age. This context produced 54 sherds (780g) from a large Deverel-Rimbury bucket urn with fingertipped rim top and cordon, and a line of perforations below the rim. The rim diameter cannot be accurately measured from the surviving sherds, but it is over 40cm diameter.
- B.1.7 The base and lower part of a similar vessel (SF2) was block-lifted from context 6602. The vessel was no doubt deposited whole, upright, with the middle and upper parts truncated (the lower wall survives up to 15cm). No diagnostic sherds are present, and the vessel might be late Bronze Age, but given the certain Deverel-Rimbury pot in 6607 from the same trench, a middle Bronze Age date is very likely. The vessel is large, with the base measuring c 36cm in diameter. Both of the middle Bronze Age vessels are in flint fabrics.
- B.1.8 Nine contexts (1205, 1506, 2704, 10604, 13404, 13508, 18306, 21006, 21407) produced small and abraded flint tempered sherds datable only to the middle Bronze Age or Iron Age.

Late Bronze Age and Iron Age

- B.1.9 Pottery from contexts 10003 and 22017 have been spot-dated to the late Bronze Age. The diagnostic sherd from 10003 was an outturned neck/rim, and the material from 22017 was a jar probably with an incurving rim although the rim was poorly preserved. The rest of the material in Trench 220 (contexts 22015 and 22016) could also be late Bronze Age date, and this includes a burnished sherd decorated with two horizontal incised lines probably on the neck in context 22015.
- B.1.10 A small, inverted vessel was block lifted from context 9705 (SF 1). This was inspected during laboratory excavation before the neck and rim was exposed. A sherd from the shoulder was visible, suggesting a late Bronze Age or early Iron Age date. The lower part of the vessel has a diameter of 9cm. The fabric contains flint and quartz sand. Vessels from contexts 1306 and 2705 also have shoulders suggesting a late Bronze Age or early Iron Age date.
- B.1.11 Four further contexts are spot-dated to the late Bronze Age or Iron Age: contexts 1003, 2720, 3203 and 3400. These contain sherds in fabrics containing quartz sand. The presence of sand might suggest these are Iron Age (e.g. Mucking: Brudenell 2016b, 160; 2016a, 380; South Hornchurch: Harrison 2000, 337-8), although this is tentative.
- B.1.12 A single context was spot-dated to the early Iron Age: 13312. This comprised sherds from an angular bowl in a sandy fabric.
- B.1.13 A single context was spot-dated to the middle Iron Age: 18417. This was a sherd in heavy glauconitic fabric, diagnostic of the period at Mucking (Brudenell 2016a).
- B.1.14 Three contexts were spot-dated to the Iron Age: 1202, 1712 and 10602. Context 1202 contained sherds in a sandy fabric with no flint; sherds in contexts 1712 and 10602 include those in a fabric containing voids, probably degraded shell. Shell temper is rare in the region, but present in Iron Age material at Mucking (Brudenell 2016b, 367-8).

Retention

- B.1.15 The pottery has future research value and should all be retained.

Context	Sherds	Weight (g)	Fabric	Spot-date	Comment
1003	1	1	QsFI2	LBA/IA	Very abraded, Qs suggests its IA
1202	13	17	Qs2; FI2	IA	
1205	2	6	FI2	MBA-IA	
1306	18	40	QsFI2; FI2	LBA/EIA	Shoulder. Could be LBA but Qs suggests EIA
1506	2	5	FI3	MBA-IA	Very abraded
1712	1	2	Sh2 (voids)	IA	
2105	1	12	FI3 (poorly sorted)	M Neo	Peterborough Ware. Incurving rim, most of outer surface abraded off - most decoration and rim form not surviving. Faint ?bird bone impression below rim
2704	1	2	FI2	MBA-IA	
2705	1	27	FI2	LBA/EIA	Slight shoulder
2720	3	13	QsFI2	LBA/IA	Could be LBA, but Qs suggests IA
3203	6	28	QsFI2; FI2	LBA/IA	Qs suggests its IA
3400	7	14	FIQs2	LBA/IA	Qs suggests its IA
6602	-	-	FI2	MBA	Poss LBA. Truncated base of large upright pot. No rim or diagnostic features. Lower part of vessel c 36cm diameter. Base and up to 15cm of lower wall surviving. Wall thickness 12mm. Inspected during lab excavation. Small find 2
6607	54	780	FI3	MBA	Sherds from on large Dev-Rim bucket urn. Fingertipped rim top and cordon. Line of perforations below rim
9702	-	-	FIQs2	LBA/EIA	Small inverted pot, block lifted. Slight shoulder. Inspected in lab when partially excavated. Lower part of vessel 9cm diameter. Small find 1.
10003	4	11	FI2	LBA	Outturned neck/rim. Could be EIA
10602	2	6	ShQs2 (voids); FI2	IA	
10604	1	1	FI2	MBA-IA	Very small and abraded
11203	1	11	FI2 (very sparse)	M Neo	Peterborough Ware. Very abraded decoration over all of body
11401	1	3	FI3 (poorly sorted)	E-M Neo	No decoration, but very small sherd
13312	2	8	Qs2	EIA	Angular bowl
13404	5	4	FI1	MBA-IA	Very abraded

Context	Sherds	Weight (g)	Fabric	Spot-date	Comment
13508	1	1	FI2	MBA-IA	Very abraded
13808	1	3	Qs2	Prehis	
18306	2	17	FI2	MBA-IA	1 grog tempered base - Residual L Neo or EBA?
18417	1	4	Qg2	MIA	
20306	2	1	-	Prehis?	Crumbs
20404	1	2	Ve2	Prehis?	Possible E/M Saxon
21006	1	6	FI2	MBA-IA	
21407	2	5	FIQs2	MBA-IA	Sample 26
22015	12	51	FI2	LBA/EIA	Inc. sherd with two horizontal incised lines probably on neck. Burnished
22016	3	4	FI2	LBA-IA	Smoothed. Sample 25
22017	13	93	FI2	LBA	A probable LBA jar with incurving neck
Total	165	1178			

Table 1: Prehistoric pottery assemblage

B.2 Roman Pottery

By Edward Biddulph

Introduction

B.2.1 Twelve sherds of Roman pottery, weighing 178g, were recovered from the evaluation (Table 2). Forms and fabrics were assigned standard Museum of London Archaeology Roman pottery codes (MOLA 2014a). The following fabrics were noted (codes in brackets from Tomber and Dore 1998):

- MHAD: Much Hadham oxidized ware (HAD OX)
- OXIDF: Miscellaneous fine oxidized wares
- OXRC: Oxford red colour-coated ware (OXF RS)
- SAND: Unsourced sand-tempered ware
- SAMLZ: Central Gaulish (Lezoux) samian ware (LEZ SA 2)
- SESH: South Essex shell-tempered ware

Context	Fabric	Sherds	Weight (g)	Comments	Spot-date
1202	OXIDF	1	2	Chip	?AD 43-410
1904	OXIDF	2	18	Body sherds; hint of rouletted decoration on one sherd	AD 43-410
2303	MHAD	1	6	Body sherd	AD 200-400
2709	SESH	1	9	Rim sherd, bead-rimmed jar, type 2A (0.03 EVE)	AD 270-400
	OXRC	1	5	Rim or flange of bowl or dish, type 4/5 (0.07 EVE)	
2803	SAMLZ	1	34	Footring base of bowl	AD 120-200
21215	MHAD	1	3	Body sherd	AD 200-400
21612	SAND	1	89	Base sherd from thick-walled vessel (?jar)	AD 43-410
21614	SESH	2	9	Rim sherd, type 2A (0.05 EVE)	AD 1-150
21707	MHAD	1	3	Body sherd	AD 200-400
Total		12	178		

Table 2: Roman pottery assemblage

B.2.2 The sherds were collected from the northern and southern parts of the site. The sherds were generally small and worn and context-groups comprised just one or two fragments. This suggests that the assemblage represents little more than a random scatter, with sherds deposited incidentally through, say, agricultural processes, possibly much later than the intrinsic date of the material. Context 2709 shows that the assemblage has a mixed character; the group comprised shell-tempered ware (SESH) of 1st-century AD date and Oxford red colour-coated ware (OXRC) of late Roman date.

B.2.3 Nevertheless, the assemblage points to Roman-period activity in the vicinity of the site. With early Roman (SESH), middle Roman (SAMLZ) and late Roman (MHAD, OXRC) material represented, this activity potentially spanned the whole of the Roman period (c AD 43-400/10).

Recommendations for retention

- B.2.4 The pottery reported on here has the potential to inform future research through re-analysis, and thus it is recommended that all the pottery is retained. This follows the advice set out in the *Standard for Pottery Studies in Archaeology* (PCRG *et al.* 2016).

B.3 Medieval Pottery

By John Cotter

Introduction and methodology

- B.3.1 A total of 259 sherds of medieval and post-medieval pottery weighing 2957g were recovered from 39 contexts. Ordinary domestic wares were recovered. A range of pottery from the early/mid Anglo-Saxon period to the 19th or early 20th century was identified.
- B.3.2 All the pottery was scanned during the present assessment and spot-dates were provided for each context. Each context group was quantified by sherd count and weight and recorded on a spot-dating spreadsheet. The pottery is in a fragmentary condition, but many fairly large and fresh sherds are present.
- B.3.3 The context spot-date is the date-bracket during which the latest pottery types or fabrics are estimated to have been produced or were in general circulation. Comments on the range of fabrics were recorded, usually with mention of vessel form (jugs, bowls etc.) and any other attributes worthy of note (e.g. decoration etc.). Fabric codes referred to are those of the Museum of London (MOLA 2014b). Where appropriate, these are cross-referenced to the fabric codes used by Essex County Council (Cotter 2000, 12-13). The range of pottery is described in detail in Table 3.

Description

Context	Spot-date	Sherds	Weight (g)	Comments
1303	c 1270-1350	19	158	2x jug sherds Mill Green ware (MG) incl fresh strap handle with white slip all-over & specks of glaze, plus small white-slipped bo. 3x Mill Green coarse ware (MG COAR, c 1270-1400). The rest = fairly fresh sherds of shelly-sandy ware (SSWX/Essex Fabric 12C) incl a sagging cook pot base & a flaring-necked cooking pot rim with a slightly cupped/collared neck & a v flat/expanded rim - the ext. surface has wheel-thrown rilling or light grooving. The fabric of this shelly-sandy ware is more like a grey sandy ware (RCWX/Essex Fabric 20) but light/mid grey & with only sparse fine shell - possibly the tail-end of the shelly ware tradition in this area? Latter possibly related to (or same as) London shelly-sandy ware (SSW, c 1140-1220)?
1503	c 1270-1350	65	412	1x bo Mill Green ware (MG) jug with part of white slip-painted scheme of dec & splashes of glaze. 20x MG COAR incl slightly worn cook pot rims & sagging base, 1 glazed int. 7-8x coarse grey sandy ware (RCWX/ Essex Fabric 20) incl jug handle with rows of pricking/stabbing down the back. The rest = mainly sherds of shelly-sandy ware (SSWX/Essex Fabric 12C) cook pots incl 1x squared rim & a few fresh sagging base sherds - sooted
1503	c 1270-1350	6	13	Sieved Sample <1>. Small bos as above incl MG COAR. RCWX, SSWX
1504	c 1270-1350	5	12	Scrappy bos. 4x MG COAR. 1x shelly SSWX

Context	Spot-date	Sherds	Weight (g)	Comments
1508	c 1270-1400	1	3	Bo MG COAR
1600	c 1270-1350	8	151	Fresh slightly sagging cook pot base in MG COAR. Int glaze. Sooted ext. The rest = shelly ware, mostly in a very smooth almost sand-free fabric with varying amounts of shell (all dissolved out) & including a squared cook pot rim in a smooth orange-brown fabric similar to Mill Green ware but with moderate shell, also 1 bo with more shell and with a thumbed strip. Closest generic match for latter fabric is Essex Fabric 12A (shelly wares without sand; or London early med shelly ware EMSH, c 1050-1150, or South Essex shell-tempered ware, SEMS, c 1100-1300, but the rim here is probably 13/E14C?)
1603	c 1270-1350	24	106	5x fresh MG incl 1 upper handle top/junction from jug with narrow strap handle & pair of classic 'ears' impressed/pulled into upper surface where joins jug neck, frosty reduced greenish-brown glaze; the other MG sherds incl 3 joining from 1 vess = jug neck with dark brown glaze, & 1 slipped bo with traces green glaze. 1x cook pot rim & few bos in shelly-sandy ware (SSWX) & several small bos in the v fine Essex Fabric 12A fabric seen in (1600)
1604	c 1270-1350	15	56	Mostly fairly scrappy bos. 2-3 fresh. 2-3x v abraded bos MG or MG COAR (1 with fine calcareous/shell inclusions). 2x coarse grey sandy ware RCWX. The rest = bos & a sag cook pot base in a smooth shelly-sandy ware with v fine sand (Essex Fabric 12A, as in (1600) above: possibly related to Mill Green ware?)
1705	c 1670-1750?	8	301	Fresh sherds. Odd mix of dates. 1x large fresh bo from globular jug in London stoneware (LONS) - cream sandy fabric with brown salt glaze. 1x Border ware (BORDG, or TUDG?) rim and pieced lug handle from small costrel in v fine fabric with green glaze - prob early 16C? 5x early post-medieval red earthenware (PMRE, c 1480-1600) incl squared jar rims & rod handle from jug. 1x bo Raeren stoneware drinking jug (RAER). 1x worn cook pot rim in shelly EMSH fabric (11/12C?)
1714	c 1200-1350?	1	4	Bo in smooth shelly ware Essex Fabric 12A as in (1600)
1804	c 1580-1750?	7	126	2x post-med black-glazed redware (PMBL) incl base of mug/tankard. 5x post-med red earthenware (PMR) incl fresh flanged rim dish. 3 sherds abraded [See clay pipe report = 1 pipe bowl c 1680-1710]
1809	c 1580-1750?	3	22	1x small bo PMBL ?mug/tankard. 2x PMRE incl flat base of jar
1815	c 1580-1900	1	49	Fresh bo PMR ?jar. Poss. 17/18C?

Context	Spot-date	Sherds	Weight (g)	Comments
1817	c 1650-1800	10	726	Odd mix of fresh medieval and post-med sherds - all redwares. 3x PMR incl broken profile wide bowl/pancheon with v heavy sub-flanged rim, hollowed on top - prob no earlier than c 1650 but might be 18C? Also 1x beaded jar rim PMR (L17/18C?). 4x fresh unglazed PMRE (Essex Fabric 40EA) poss 16C? 1x fresh rim (98g) from Mill Green jug (MG, c 1270-1350) with strap handle - thin white slip all-over ext but no glaze. 4th bag with 1x fresh 17C PMR wide bowl with hooked flanged rim. Nb: this pot came in 4 different bags with pot of different dates in each (i.e. med, 16C and 17-18C), possibly collected from different areas of same context?
1906	c 1480-1600	2	28	1x fresh jug bo Essex early post-med redware (Essex 40EA/ London PMRE). 1x small bo gritty med greyware (RCWX)
1909	c 1480-1600	2	26	1x fresh jug bo Essex early post-med redware (Essex 40EA/ London PMRE) - probably JOINS (1906). 1x small bo in same PMRE fabric but with grey core
2105	c 1550-1625?	6	27	1x bo from shoulder/neck of Frechen stoneware (FREC) girthband-type jug with part of an applied small circular portrait medallion (trace of human head inside medallion; no girthband surviving). 5x small bos PMRE incl sherd poss. from conical lid?
2207	c 1270-1400?	2	4	1x small sherd from jug with beaded/thickened rim in reduced fine grey ware with brown core - probably unglazed MG? 1x abraded scrap MG COAR
10604	c 1550-1900	2	3	Joining scraps. 9mm thick. Fine orange sandy fabric with amber-brown glaze ext. Probably PMR
10605	c 1580-1750?	1	25	Worn bowl/dish base PMR
10900	c 1270-1350	1	3	Bo MG COAR
12004	c 1805-1900	2	16	1x bo Staffs-type refined whiteware (REFW). 1x bo PMR flowerpot - probably 19C
12804	c 400-600	3	77	Anglo-Saxon. 2 vessels - fairly fresh. Both in sandy organic-tempered ware (CHSF). 1 large bo & joining scrap/flake from a globular thick-walled jar with 3 rows of rusticated/deeply pinched decoration (possibly 4 rows?) & an undecorated zone ?above this? Orientation of latter sherd uncertain but the dec seems to be near the base of the vess. 1x thick, flattish bo with moderate organic temper but same fabric as the dec sherd. Both have a coarse sandy-gritty fabric with rare coarse flint and moderate coarse black (crystalline) iron oxide/ironstone. Date possibly within L5-6C (on basis of dec)?
13504	c 1550-1700	1	38	Land Parcel 49W. PMR. Sherd from bunghole jar/jug with c 50% of bunghole collar surviving. Fine early PMR? Rare-sparse quartz grits. Abraded

Context	Spot-date	Sherds	Weight (g)	Comments
13604	c 1750-1780	1	34	Land Parcel 49W. Staffs white salt-glazed stoneware (SWSG). Dish profile with moulded basket & diaper design on rim flange. Fresh
15105	c 1200-1350?	5	42	Sieved Sample <154>. Scrappy bos. 2x developed oxid shelly-sandy ware (SSWX/ Essex Fabric 12C). 1x worn Essex early med sandy (Fabric 13? or London EMS?). 1x very abraded scrap ?Roman tile? (6g)
18505	c 1050-1225?	8	29	Sieved Sample <33>. Scrappy bos shelly EM SHX as in 18511. Also 1x cook pot rim with internally bevelled rim (c 1050+?) - in shelly ware with moderate coarse shell (dissolved), sparse sand (finer EM SHX? or London early med shelly EM SH, c 1050-1150?)
18509	c 1000-1225?	7	11	Sieved Sample <32>. Scrappy bos early shelly ware EM SHX as in 18511
18511	c 1000-1225?	6	41	1 vess. Fresh bos from cook pot in shelly ware with moderate sand. Very coarse platy shell - mostly dissolved. Dark brown surfaces, grey core. Sparse flint. Probably Essex EM SHX (c 1000-1225)
18513	c 970-1100?	15	208	Mostly 1 fresh cooking pot with simple everted, underscored rim on near-cavetto neck - brown very sandy with grey core, rare-sparse flint and sparse-moderate limestone/chalk inclusions - probably London early medieval sandy ware (EMS, c 970-1100, or Essex Fabric 13 variant? c 1025/50-1225), rare coarse flint grits, limestone mostly dissolved from surfaces. 1x worn bo oxid Late Saxon shelly ware with coarse flint inclusion (LSS, c 900-1050)
18518	c 1000-1225?	2	2	Small bos. As in 18511 slightly sandy shelly ware. Probably EM SHX
19605	c 1275-1350	1	6	MG COAR jar/cook pot rim. Everted thickened. Brown glz splash ext
21900	c 1875-1925	1	32	Land Parcel 40D. English porcelain (ENPO). Complete flat base from a small hollow, moulded, statuette (diam 34mm). Low-grade plain white porcelain (English or Central European?). Thick-walled. Human cartoon-like figure with stylized trousers with a pair of stubby shoes just visible at front. Above trousers is the hem of a coat/cloak. Parallel drag marks (or gripping grooves?) on underside of base where cut from the mould or turntable.
21906	c 1100-1350	2	8	Land Parcel 40D. Small bos (body sherds) shelly-sandy ware (London Fabric SSWX/Essex Fabric 12C)
21909	c 1000-1225?	4	42	Land Parcel 40D. Worn sagging base and bos shelly ware with sparse fine sand and dissolved-out shell voids. Probably Essex EM SHX (c 1000-1225)? Or London early med shelly ware (EM SH, c 1050-1150)?

Context	Spot-date	Sherds	Weight (g)	Comments
21914	c 1000-1225?	4	14	Land Parcel 40D. Worn shoulder sherd from jar/cook pot, and bos, in shelly ware, probably Essex EMSHX (c 1000-1225)? Or London early med shelly ware (EMSH, c 1050-1150)? 1x bo in sandier/coarser shelly fabric
22020	c 1000-1225?	2	46	Land Parcel 40D. Fairly fresh sagging base from jar/cook pot, and small bo, shelly ware with sparse fine sand and dissolved-out shell voids. Base has rare-sparse very coarse angular flint inclusions and sparse coarse rounded quartz. Probably Essex EMSHX (c 1000-1225)? Or London early med shelly ware (EMSH, c 1050-1150)?
22026	c 1000-1225?	5	44	Land Parcel 40D. 2x fresh joining bos sandy greyware, handmade, probably Essex early medieval sandyware (Fabric 13, c 1025/50-1225) or London early med sandy ware EMS, c 970-1100)? 3x shellyware including simple everted jar/cook pot rim - probably Essex EMSHX (c 1000-1225)? Or London early med shelly ware (EMSH, c 1050-1150)?
99999	c 1175-1350?	1	12	Land Parcel 40D. Wheel-turned jar/cook pot rim. Uniform sandy greyware - fairly coarse. Everted/slightly flanged rim similar to late Saxon-Norman forms (similar but too coarse for Thetford-type ware THET). Possibly Essex grey sandyware (Fabric 20, c 1175-1350) or an unidentified 11-12C sandy ware? Heavily sooted ext under rim
Total		259	2957	

Table 3: Description of post-Roman pottery by context

Discussion

- B.3.4 The pottery comprises ordinary domestic wares typical of this part of south Essex and covers a date range from the early/mid Anglo-Saxon period through to the 19th or early 20th century. However, most of the of pottery is of high medieval and early post-medieval date.
- B.3.5 A single context (12804) produced 3 sherds of Anglo-Saxon pottery in a sandy organic-tempered fabric (CHSF). One of the two vessels represented here has rusticated decoration suggesting a date in the late 5th or 6th century.
- B.3.6 Some potentially late Saxon or late Saxon-Norman pottery occurs in a few contexts - mainly those with contexts numbers in the 18500s (Trench 185?) and the 21,000s and 22,000s (Trenches 210 and 220?). The condition of some of these, however, is often poor (particularly the shell-tempered wares) and positive identification to known fabric codes is sometimes only approximate, but a broadly 11-12th century date for these is likely. Context (18513) has fresh sherds from a cooking pot in London early medieval sandy ware (EMS, c 970-1100) and a small body sherd possibly in London late Saxon shelly ware (LSS, c 900-1050). A few other sherds occur in a sand-free shell-tempered fabric similar to London early medieval shelly ware (EMSH/EMSHX, c 1000-1225). In some cases, however, these early-looking pieces are residual in later contexts (e.g. 1705). Other types of shelly ware which occur here appear to be of later date (see below).

- B.3.7 Most of the pottery here (12 contexts) can be dated to c 1270-1350 with a fair degree of confidence because of the presence of glazed and white-slipped, or slip-painted, jug sherds in Mill Green ware (MG). Mill Green ware was produced at Ingatestone in central Essex and had a wide distribution in Essex and the Thames estuary area. Mill Green coarse ware (MG COAR), used for cooking pots and bowls, was another product of this industry and may have a slightly wider date range (c 1270-1400).
- B.3.8 The same group of contexts (with Mill Green wares) produced a small number of other local wares. These included some jug and cooking pot sherds in Essex medieval grey sandy ware (RCWX/Essex Fabric 20). Sherds from shelly-sandy ware cooking pots (London SSWX; Essex Fabric 12C) are present here too. Also present in these contexts are a few sherds from cooking pots in a very fine/smooth brown fabric with sparse-moderate shell inclusions (mostly dissolved). These seem to be in a fabric similar, or related, to Mill Green coarse ware, and include a developed-looking cooking pot rim (1600) which is very probably contemporary with the Mill Green industry. These have been noted in Essex previously and fit somewhere within the Essex tradition of 'shelly wares without sand' (Fabric 12A). This may be the same as the London area code for 'South Essex shell-tempered ware' (SEMS, c 1100-1300), but the fabric here may have remained in production as late as c 1350. Altogether, the pottery from this group of contexts attests to significant occupation here in the high medieval period.
- B.3.9 Post-medieval pottery is common here too. Most of this falls within the early post-medieval bracket (c 1500-1750). Local post-medieval redwares form the largest group here (PMRE, PMR, PMBL), present in the form of commonplace domestic crockery, such as wide bowls, dishes, jars, jugs, and conical mugs. Context (1705) produced the top of an unusually small lug-handle costrel (globular flask) in green-glazed Surrey Border ware (BORDG); this is probably a 16th-century piece but residual in a 17th-18th century context. The same context contained a sherd of German Raeren stoneware (RAER, c 1480-1550). The only other imported Continental item was a sherd from a (German) Frechen stoneware jug (FREC) with traces of distinctive decoration, including applied classical bust medallions, dating it to c 1550-1625 (2105).
- B.3.10 Later pottery is fairly rare. There is a single dish sherd in Staffordshire white salt-glazed stoneware (SWSG) datable to c 1750-1780. Two sherds of 19th-century pottery came from (12004) including a sherd of Staffordshire-type refined white earthenware (REFW, c 1805-1900) and a sherd of red flowerpot of about the same date. The latest piece, dating to c 1875-1925, is from the base of a moulded statuette in English porcelain (ENPO, Ctx 21900).

Recommendations regarding the conservation, discard and retention of material

- B.3.11 The pottery here has potential to inform research through reanalysis. It should therefore all be retained and properly catalogued and reported at some future date, along with material from any subsequent formal excavations in this area.

B.4 Flint

By Lawrence Billington

Introduction and methodology

- B.4.1 A small assemblage of 49 worked flints was recovered during the evaluation, alongside 3072g of unworked burnt flint. The assemblage is quantified by type and context in Table 4.
- B.4.2 The assemblage was catalogued directly onto an Excel spreadsheet and the artefacts were classified according to a system of broad artefact/debitage types based on standard definitions for post-glacial lithic assemblages from southern Britain (e.g. Bamford 1985, 72-77; Healy 1988, 48-9; Butler 2005). Additional information on selected technological and non-metric attributes of the material (including platform type/preparation, hammer mode and dorsal cortex coverage) was also recorded using standard classifications and terminology based largely on those set out by Inizan and colleagues (1999).

Raw material and condition

- B.4.3 The entire assemblage is made up of flint. Whilst the worked flint is quite varied in terms of colour and texture it is generally fine grained and of good quality and includes a number of relatively large removals derived from very high-quality cobbles of mottled dark grey flint. Where cortical surfaces survive, they are thin and abraded and there is no evidence for the use of flint collected from deposits closely associated with the parent chalk. It is possible, but by no means certain, that much of the flint could have been sourced locally from the Boyn Hill gravels and head deposits which underly the site, or from the lower lying Lynch hill gravels to the west.
- B.4.4 The condition of the flintwork varies, but a large proportion of the assemblage exhibits minor edge damage and rounding consistent with a degree of post-depositional disturbance, and some pieces exhibit more severe and extensive edge damage. Recortication ('patination') is rare, with only two pieces, a crested blade and a core fragment both from ditch 1202 (Trench 12), displaying incipient decortication in the form of a light blue sheen/clouding.

Context	Cut	Context type	Sample	Chip	Irregular waste	Flake	Blade/let	Blade-like flake	Crested blade	End scraper	Side scraper	Thumbnail scraper	End and side	Misc. scraper	Piercer	Microlith	Re-flaked ground	Misc. retouched	Core fragment	Total worked	Unworked burnt count	Unworked burnt count (g.)
1201	1201	Natural layer					2													2		
1203	1202	Ditch				1	1	1												3		
1205	1202	Ditch					1													1		
1208	1202	Ditch			1				1										1	3		
1213	1212	Pit	7																	0	18	76
1305	1305	Colluvial Layer				1		1												2		
2003	2002	Ditch	6																	0	150+	1330
2705	2702	Pit														1				1		
3403	3402	Pit	5																	0	3	8
4401	4401	Natural layer				1														1		
4703	4702	Pit	4																	0	3	7
4705	4704	Ditch				1														1		
7500	7500	Ploughsoil				1														1		
7601	7601	Natural layer				1														1		
7800	7800	Ploughsoil													1					1		
11401	11401	Subsoil				1	1													2		
11402	11402	Natural layer				1														1	1	11.6
11404	11403	Pit	8																	0	18	47
11404	11403	Pit				1														1		
12704	12703	Pit				1														1		
16001	16001	Subsoil				1														1		
16103	16102	Ditch	23																	0	4	28
19604	19602	Ditch																		0	1	10.4
19900	19900	Ploughsoil				1														1		

Context	Cut	Context type	Sample	Chip	Irregular waste	Flake	Blade/let	Blade-like flake	Crested blade	End scraper	Side scraper	Thumbnail scraper	End and side	Misc. scraper	Piercer	Microlith	Re-flaked ground	Misc. retouched	Core fragment	Total worked	Unworked burnt count	Unworked burnt count (g.)
20203	20203	Natural Feature				1														1		
20305	20305	Natural Feature				3			1					1						5		
20306	20304	Tree-throw			2				1		1	1						1		6	2	440
20308	20304	Tree-throw			1	5					1									7		
20900	20900	Ploughsoil				1														1		
21308	21305	Pit	20	1																1		
21400	21400	Ploughsoil															1			1		
21705	21704	Ditch						1												1		
21800	21800	Ploughsoil				1														1		
21806	21805	Pit				1														1		
22008	22007	Ditch	24																	0	26	62.3
22011	22010	Ditch																		0	16	287.6
22015	22014	Pit																		0	3	16.5
22016	22014	Pit	25																	0	250+	180
22016	22014	Pit																		0	45	238
22017	22014	Pit																		0	39	256
22020	22018	Ditch																		0	8	46.6
22024	22023	Ditch																		0	1	10
22026	22025	Pit																		0	1	6.9
22208	22207	Ditch																		0	1	9.7
Total				1	4	24	5	3	1	2	1	1	1	1	1	1	1	1	1	49	450+	3071.6

Table 4: Quantification of flint assemblage

Worked flint: distribution and characterisation

- B.4.5 The 49 worked flints were recovered from 19 individual Trenches (Trenches 12, 13, 27, 44, 47, 75, 76, 78, 114, 127, 160, 199, 202, 203, 209, 213, 214, 217, 218), and derived from ploughsoil/subsoil deposits (nine pieces), a colluvial deposit (two pieces), natural layers (five pieces), natural features (19 pieces) and cur features (ditches and pits: 14 pieces). The flint was thinly distributed and, in most cases, individual trenches produced only single worked flints. The only significant exceptions to this were slightly more substantial assemblages from Trenches 12 and 203, which produced totals of nine and eighteen worked flints respectively.
- B.4.6 The worked flint from Trench 12 includes two pieces derived from natural layer 1201 and seven pieces from the fills of ditch 1202, the latter almost certainly representing residual material caught up in the fills of a later feature. These flints are overwhelmingly dominated by fine blade-based removals, including a fragment of crested blade (from fill 1208 of ditch 1202), a large prismatic blade measuring 78mm long (natural deposit 1201), a possible core tablet (fill 1203, ditch 1202) and a core fragment probably deriving from a single platform blade core (fill 1208, ditch 1202). It is unclear to what extent this small group of flintwork should be seen as representing a single period assemblage, and the absence of retouched tools renders precise dating difficult, but on the basis of the prismatic form of some of the blades and the presence of the crested blade it is very likely that much of this material is of Mesolithic date.
- B.4.7 The 18 worked flints from Trench 203 derive from two natural features, 20304 and 20305. Although no refits were found among the material from either feature, they are in good condition and give every appearance of representing coherent, single period assemblages. Feature 20305 produced five flints; three simple flakes/flake fragments, an end scraper and a fragment of a second probable scraper. The two fills of feature 20304 produced a slightly more substantial assemblage of thirteen worked flints. This included two pieces of irregular shatter and five simple hard hammer struck flakes/fragments, alongside five retouched pieces. Apart from a single flawed flake with some minor edge retouch, these retouched forms were all scrapers; one of these is a somewhat irregular side scraper made on a decortication flake, but the remaining three are all small regular, carefully retouched pieces, classed as thumbnail, end and end and side scrapers. These diminutive, extensively retouched pieces, especially the thumbnail form, are highly characteristic of Beaker/early Bronze Age industries and it is very likely that this material, and that from adjacent feature 20305 are of this date.
- B.4.8 Apart from the flint from these two trenches, the remainder of the flint was very thinly distributed. 'Early' blade-based material includes individual blades/blade-like flakes from Trenches 13 and 114 and, more significantly, a single microlith, certainly of Mesolithic date, recovered as an isolated find from a feature in Trench 27 (pit 2702). This piece is missing its proximal end, rendering precise classification difficult but it is a relatively large form, made on a fine prismatic blade, measuring >31mm long and 10mm wide, and bears typically abruptly retouched backing along its entire left lateral edge. This retouch becomes more abrupt and extensive towards the proximal end of the piece, suggesting it may have ended in an oblique truncation, and in its original form would probably have taken the form of a straight backed bladelet or backed point. Precise dating of this individual, incomplete piece is difficult, but this kind of relatively broad, fully backed form, perhaps based on an oblique truncation, is more typical

of earlier Mesolithic industries than those of later Mesolithic geometric/narrow-blade type (Jacobi 1978, cf. Barton and Roberts 2004; Conneller et al 2016).

- B.4.9 The remainder of the worked flint does include some flake-based material which is likely to postdate the earlier Neolithic and relate to later Neolithic and/or early Bronze Age activity. Among this later material the most distinctive and significant piece is a re-flaked ground flint axehead from the ploughsoil of Trench 214. This appears to represent part of the mid-section of a completely ground axehead which has been reworked as a discoidal core (weighing 129.7g). It retains areas of ground/polished surface on both faces, and along part of one edge the side facet of the axehead survives. It is made on a distinctive opaque, mottled grey flint of a kind that was frequently selected for axehead manufacture during the Neolithic period, and is well known from across Southern Britain (see Whittle *et al.* 2011, 783-8; Healy 2020, 187).
- B.4.10 Another retouched tool was recovered from the ploughsoil in Trench 78; a piercer with a short point formed on the lateral side of a flake, of a type often referred to as a spurred piece (Smith 1965, 105), is not strongly diagnostic but is likely to relate to activity during the later Neolithic/early Bronze Age.

Unworked burnt flint

- B.4.11 Of the 3072g of unworked burnt flint, a relatively large assemblage weighing 1330g was recovered from the residues of bulk sample taken from the fill of ditch 2002 (Trench 22; fill 2003, Sample 2003). A second substantial assemblage of burnt flint (690g) in total, came from the fills of pit 22014 in Trench 220. The material from both these contexts was made up of highly fragmented, heavily burnt spalls and chunks, none of which measured in excess of 50mm in size. This material is typical of flint which has experienced significant, and possibly repeated, episodes of thermal shock.
- B.4.12 The remainder of the burnt flint was recovered in small quantities from samples taken from the fills of other cut features, and in most cases seem likely to represent material incidentally incorporated into their fills.

Discussion

- B.4.13 Given the scale of the evaluation, the worked flint assemblage can only be considered small. The most significant aspect of the assemblage is the probable Beaker/early Bronze Age flintwork from a pair of natural features in Trench 203. The flintwork from these features is characterised by a very high proportion of retouched tools (dominated by scrapers) and seems likely to reflect the residue of an episode of domestic type activity/settlement. The composition of the assemblage and the character of the retouched tools can be closely compared to assemblages of Beaker/early Bronze Age associated flintwork from elsewhere in the region, including those recovered locally from the excavations at Mucking (Healey 2016, 88, fig. 2.28).
- B.4.14 Apart from this, the assemblage is otherwise notable for including a high proportion of Mesolithic/early Neolithic blade based flintwork, including something of a concentration of material from Trench 12. Given the technological traits of some of the material from Trench 12 and the single, isolated, microlith from pit 2702 (Trench 27), it is very likely that much of this material attests to activity during the Mesolithic, although the reworked ground axehead from Trench 214 certainly testifies to some Neolithic activity. The material from Trench 12 includes two pieces from natural deposits which may indicate the potential for in situ/minimally disturbed flintwork to survive in such deposits in this area, whilst it is thought likely that the larger number

of pieces recovered from ditch 1202 in this trench represent residual material derived from scatters cut through by a later feature.

B.5 Fired Clay

By Cynthia Poole

Introduction

B.5.1 A small quantity of fired clay amounting to 54 fragments weighing 404g was recovered from Trenches 12-3, 15-6, 20, 47, 114, 128, 161, 185 and 203. The assemblage consists of small fragments, poorly preserved and abraded with a mean fragment weight of 7.5g. The assemblage is not datable due to an absence of diagnostic material. The assemblage is summarised in Table 5 below and has been more fully recorded on an Excel spreadsheet in accordance with guidelines set out by the Archaeological Ceramic Building Materials Group (ACBMG 2007), which whilst not specifically for fired clay provide appropriate guidance. Fabrics were characterised on the basis of macroscopic features supplemented by the use of x20 hand lens for finer constituents.

Fabrics

B.5.2 All the material was made in a similar fabric composed of a fine sandy silty clay containing a sparse scatter of medium-coarse quartz sand and generally fired red or reddish brown. This probably derives from local clay deposits ultimately weathered from the London Clay, which underlies the site.

Description

B.5.3 Most of the fired clay has no distinctive features and little surviving original surface. Pieces were either amorphous or retained a single rough moulded flat surface. One piece possibly had remnants of two small stem or wattle impressions 6-7mm in diameter, but these were very unclear. A few pieces had a burnt blackened surface. Most of the fired clay is probably structural in origin from oven or hearths of a domestic character or for crop processing. Much of it could be the natural clay burnt *in situ* where such structures were set into the natural clay surface, which served as the walls or floor of the structure.

Context	Sample	Count	Weight (g)	Form	Comments
1202	~	1	3	Indeterminate	
1205	~	1	4	Indeterminate	
1213	<7>	10	175	Structural?	?oven/hearth
1303	~	7	33	Structural?	?oven/hearth Surface burnt dark grey
1503	~	8	22	Structural?	?wattle/stem impressions
1503	<1>	2	7	Indeterminate	
1604	~	1	3	Indeterminate	
2005	~	1	12	Structural?	?oven/hearth
4703	<4>	10	31	Structural?	?oven/hearth
11404	<8>	3	8	Indeterminate	
12804	~	1	10	Furniture?	Briquetage pedestal/firebar?
16103		3	75	Indeterminate	
18518		2	5	Indeterminate	
20305		4	16	Indeterminate	
Total		54	404		

Table 5: Summary of fired clay assemblage

- B.5.4 Only one piece might be remains of an item of portable oven or hearth furniture (ditch fill 12804). This appeared to be a fragment of linear rectangular object with sub-square cross-section measuring something over 20mm wide and over 36mm long. It mostly consisted of the black fired core with heavily abraded remnants of the exterior fired yellowish brown and cerise red, though all original surface appeared to have worn away. The contrasting colours are suggestive of briquetage and it may possibly be the remains of the stem of pedestal such as a late Bronze Age-early Iron cup pedestal or otherwise some sort of firebar.

Conclusion

- B.5.5 The evidence of the fired clay is very limited: the assemblage contains no pieces that can be regarded as diagnostic and none can be dated. The fired clay is reliant on other datable materials for its phasing, but very little of the fired clay is associated with other dated artefacts. Fired clay from ditch 1202 is associated with Roman tile and pottery and also middle Bronze Age-Iron Age pottery and the object from ditch 12804 was associated with Anglo-Saxon pottery. There is virtually no overlap with other dated artefacts. It is possible therefore the fired clay is not primarily associated with any one period of settlement but reflects small scale activity over a long time-scale. In terms of function, the fired clay is most likely to derive from domestic oven or hearth structures or possibly crop processing ovens. The association of some fired clay with other burnt debris in the form of burnt flint, charcoal and carbonised plant remains including wheat and barley cereal grain supports such an interpretation.
- B.5.6 The single piece that might be an item of portable oven/hearth furniture such as a fire bar or pedestal may have been associated with salt working, based largely on its colour, though its form is poorly preserved. If this is the case, the piece must be residual as it was found in a context dated to AD 400-600 by the associated pottery. Prehistoric and Roman salt working debris has been found at a number of sites in this part of the Thames floodplain, including Mucking and Stanford Wharf Nature Reserve.

Recommendations

- B.5.7 The assemblage is small, poorly preserved and has limited further research potential. The only piece that may be considered worth retaining is possible briquetage object and even this doubtful. The assemblage may therefore be discarded if desired at completion of the project.

B.6 Ceramic Building Material

By Cynthia Poole

Introduction

- B.6.1 A total of 74 fragments of CBM weighing 7589g were recovered from Trenches 12, 17-23, 27, 78, 88, 106, 212, 213, 214, 216, 219, 220 and 222 (Table 6). The material is all fragmentary but includes a few half bricks and has a fairly high mean fragment weight of 136g as a result. The assemblage includes a few pieces of Roman date, but otherwise consists overwhelmingly of early post-medieval material.
- B.6.2 The assemblage has been fully recorded on an Excel spreadsheet in accordance with guidelines set out by the Archaeological Ceramic Building Materials Group (ACBMG 2007). The record includes quantification, and details of fabric type, form, surface finish, markings and evidence of use/reuse (mortar, burning etc). Fabrics were characterised on the basis of macroscopic features supplemented by the use of x20 hand lens or binocular microscope at x25 for finer constituents and have been assigned Museum of London fabric codes (MOLA 2014c & d). Virtually all the CBM was made in red-orange fine sandy clay fabrics.

Roman tile

- B.6.3 Roman tile (6 fragments, 876g) comprised brick, a large fragment of tegula, and flue tile together with three indeterminate/flat tile fragments, two of which could not certainly be distinguished as CBM rather than fired clay.
- B.6.4 The large fragment of tegula, weighing 227g (context 22020) was made from an orange pink fine fabric with white silty streaks, occasional medium quartz, a mottled clay matrix and occasional red ferruginous grits up to 2mm long. The tile was 17mm thick and had a rectangular flange profile (profile A). The flange itself was 17mm wide and 39mm high. There was no cutaway present on the flange. This fragment is well preserved and is suggestive of a substantial Roman building in the area. Roman pottery has previously been recorded very close to the site during the Pond 1812 and Strip Widening within the western part of Land Parcel 40 (Biddulph and Brady 2015). Roman settlement activity was also recorded 500m north-west of the site during the Manor Farm excavations in 1983-4. This comprised two rectangular enclosures containing 2nd and 3rd century activity, cremation burials and industrial activity (MOLA 2011).
- B.6.5 The flue tile (context 1202) measured 20mm thick and was keyed with a single straight band of combing measuring 30mm wide and with six teeth. This flue tile was recorded 500m east of the Roman settlement activity recorded by MOLA and suggests there was a heated Roman building in the vicinity of the site. The inner surface was heat discoloured. The brick (context 2704) measured 34-35mm thick increasing slightly to the edge and had a wiped striated upper surface with finger marks and rough base and edge. The surfaces had all been heat discoloured. The other indeterminate fragments all had evidence of secondary burning.
- B.6.6 The tegula and flue tile fragment may well be associated with the Roman settlement at Manor Farm located 500m north-west of the site. The rest of the tile forms a sparse scatter across the site and represents incidental discard probably as a result of agricultural practice such as manuring. The evidence of burning suggests reuse in

oven or hearth structures indicating the fragments had been through several cycles of use and reuse prior to their final deposition.

Medieval-post-medieval CBM

- B.6.7 Medieval-post-medieval roof tile and brick exhibited a distinct focus spatially on Trenches 17-23 in the north-west sector of the site and temporally in the late 15th-17th century. CBM in Trenches 78, 88 and 106 were all close to the eastern edge of the site. There was also a concentration of medieval-early post-medieval CBM in the southern part of land parcel 40 in Trenches 203, 212, 213, 214, 216, 219, 220 and 222.
- B.6.8 Brick (32 fragments, 4701g) was all hand-made with rough surfaces, with some creasing of the edges and coarse straw/grass impressions on the base of one. Two bricks had an indented border measuring 9 and 22mm wide in the upper surface alongside one edge. Nearly all bricks with any complete dimensions came from context 1804: these measured 47-57mm thick and 108-123mm wide. No complete lengths survived. One brick from context 7803 was slightly thicker at 60mm. The brick fragments from contexts 21203, 21404 and 21611 were all heavily abraded. All are dated to 15th-17th century, with the focus possibly to the earlier half of this range.
- B.6.9 Roof tile (32 fragments, 1960g) included flat rectangular peg tile and curved ridge tile. The peg tile was all very similar in character having wiped striated lumpy upper surfaces, the lumpy character resulting from hard clay pellets within the fabric. Undersides were rough but fairly even, sometimes creased and coated in fine moulding sand with a rare plant impression present. The peg tile measured 12-17mm thick, with most averaging 13mm, but no other dimensions survived complete. Peg holes survived on five pieces. Four of the peg holes were circular measuring 13, 14 and 16mm in diameter and were centred 18-36mm from the top edge and 22-50mm from the side edge. In two cases pairs of peg holes survived and were set 38 and 50mm apart. Three peg holes exhibited thickened halos of clay encircling the hole on the underside measuring 27-36mm in diameter. A single tile retained the edge of a square peg hole 11mm wide set 19 and 53mm from the top and side edges. One tile had on the upper surface the imprint of half of a dog paw comprising three toe pads, two claw marks and part of the heel pad measuring in total 58mm long. These have been assigned the same broad 15th-17th date as the brick based on a combination of standard dating of the fabric and the crude finish of the tiles.
- B.6.10 Ridge tile included a single small, curved fragment 12mm thick similar in character in terms of surface finish to the peg tile and probably of the same date. The second example (context 8803) is very different in character and probably of later 18th-19th century date. It was made in a red sandy fabric containing a high density of coarse-medium quartz sand, with occasional flint grits 3mm. Both upper and lower surfaces are smooth and finely striated. It measures 19mm thick and the curvature indicates a diameter of c 190mm, suggesting this is a large half-round ridge tile. Alternatively, this could be a drainpipe though with no edges surviving this cannot be verified. However, the diameter is too great for a field drain and the fabric is atypical of water and sewer pipes, therefore identification as ridge is preferred.
- B.6.11 A single example (48g) of Flemish type floor tile (context 1804) is dated to 15th-16th century. It measures 29mm thick and has a white slip over the surface covered by an amber glaze creating a typical yellow surface.

Context	Spot date	Count	Weight (g)	Form	Fabric	Comments
1202	RB	1	97	Tubulus	Mol2452	Combed keying
1205	RB?	1	21	Indet	Mol2452	
1705	LC15-C17	1	54	Roof tile	Mol2276	
1710	LC15-C17	2	287	Roof tile	Mol2276	
1804	LC15-C17	10	4149	Brick, Roof tile/peg, Floor tile	Mol3030, 3032, 3033, 3046, 2276, 1977	Conical peg hole & dog paw print on peg tile
1809	LC15-C17	9	101	Brick, Roof tile	Mol3046, 2276	Incl 2 fragments of poss RB tile or fired clay
1817	LC15-C17	5	484	Roof peg tile	Mol2276	Circular peg holes
1904	LC15-C17	2	10	Roof tile?	Mol2276	
1909	LC15-C17	2	184	Roof tile	Mol2276	
2005	LC15-C17	2	5	Roof tile?	Mol2276	
2105	LC15-C17	7	76	Brick, Roof tile	Mol3046, 2276	
2207	LC15-C17	1	23	Roof tile ?ridge	Mol2276	
2303	Undated	1	5	Flat tile	Mol2271/2452?	
2704	RB	1	511	Roman brick	Mol2452	
7803	MC15-C17	1	715	Brick	Mol3033	60mm th
8803	C18-C19?	3	231	Curved tile	Mol?	?ridge or pipe
8804	LC15-C17	1	96	Roof tile	Mol2276	Square peg hole
10605	MC15-C17	3	179	Brick, Roof tile	Mol3033, 2276	
21203	MC15-C17	5	30	Brick	Mol3046	
21304	LC15-C17	1	8	Roof tile	Mol2276	
21404	MC15-C17	6	61	Brick	Mol3033	
21611	L15-EC17?	3	11	Brick	Mol3032	
21906	LC15-C17	1	5	Indeterminate	Mol2276	
22011	Pmed	1	1	Indeterminate	Mol3046?	
22020	Roman	1	227	Tegula	Mol3238	Flange profile A - 17mm wide and 39mm high. No cutaway.
22024	MC15-C17	1	13	Indeterminate	Mol3046	
22204	MC15-C17	2	5	Indeterminate	Mol3046	
Total		74	7589			

Table 6: Summary of ceramic building material assemblage

Conclusions

B.6.12 The post-Roman assemblage is predominantly of mid-late 15th-17th century date and is concentrated in the NW area of the site, and the southern part of the site suggesting

it relates to activity of this date in these areas. The combination of brick, roof and floor tile from the NW part of the site suggests it derives from a building of some standing and burning on the edge of some tile indicates the presence of a hearth or oven. No evidence of buildings having stood in the area is suggested on early maps, nor was anything identified in the WSI but this part of the site lies fairly close to Pike Lane, which runs south to Manor Farm. It is possible the building material provides evidence of a Tudor building having once stood in the vicinity, though with a parish boundary running across this area it is perhaps an unusual outlying situation for a building.

- B.6.13 The concentration of medieval/early post-medieval brick and tile in the southern part of the site (Trenches 212, 213, 214, 216, 219, 220 and 222) suggests there was a 15th-17th century building in this area. However, these fragments were recorded within ditches suggesting the building had been demolished before fragments were deposited. During the M25 widening excavations linear ditches and possible enclosures dating to the 10th-12th centuries were found within the western part of Land Parcel 40 (Biddulph and Brady 2015). This rural activity is earlier than the CBM, but it is suggestive of medieval activity close to the site. This southern part of the site is also located just south of a green lane leading from Pea Lane which is shown on later 19th and early 20th century OS maps (Highways England 2020, WSI H). It is possible that there was a medieval/early post-medieval group of buildings located just south of this green lane. The green lane led to the medieval/post-medieval manor of North Ockendon Hall which was located 400m north-east of this southern group of trenches.

Recommendations

- B.6.14 The fragments of Roman tegula and flue tile should be retained as they may relate to Roman settlement activity at Manor Farm located 400m west of the site. The value of the post-Roman assemblage is in providing supplementary dating evidence for the contexts and evidence of structures or activities on site. The material has little additional intrinsic research value and in general, the archive record should be sufficient in any wider research encompassing the site or the material. According to Museum of London archiving standards (MOLA 2013), with the exception of the tegula and flue tile fragments, all material should be discarded following completion of recording and prior to archiving.

B.7 Metals

By Anni Byard

Introduction

B.7.1 A total of 27 metal objects (889g) were recovered during the evaluation. This material comprises 26 iron objects (841g) and one lead alloy object (48g) recovered from 10 contexts across seven trenches (Table 7). Most of the artefacts are heavily encrusted fragments and are not closely datable on their own; however, those that are datable are generally of later post-medieval or modern date.

B.7.2 The metalwork was scanned during the present assessment and, where possible, century or broad period dates were assigned. Objects were quantified by type count and weight by context, and recorded on a spreadsheet.

Description

Context	Material	Count	Weight (g)	Object	Date	Description
1200	Pb	1	48	Scrap		Torn and bent lead alloy strip with no obvious form.
1404	Fe	1	6.3	Nail		Bent nail shank fragment
1705	Fe	1	5.6	Nail		Incomplete nail with square shank and rounded head. Encrusted.
1804	Fe	1	88.3	Horseshoe	PM / mod	Probable horseshoe section, encrusted. No visible holes. Probably 1600-1900
1809	Fe	1	24	Hoop		Ring or loop, heavily encrusted with a flint stone through the middle. Uncertain form and function
1809	Fe	1	46			T-shaped object of uncertain function, with possible circular object adhering to it. Heavily encrusted
1809	Fe	1	82.7		PM / mod	Sub-square iron plate in 2 pieces with rounded edges and possibly slightly raised lip. Possible central rivet. Encrusted. Possible boot heel plate?
1809	Fe	5	16.7	Rod		Five rod fragments, slightly curved. One is hooked.
1809	Fe	3	18.8	Nail		Nail fragments

Context	Material	Count	Weight (g)	Object	Date	Description
1809	Fe	1	7.1	Nail		Complete but encrusted nail. Tapering rectangular section and small square head. Roman - PM
1811	Fe	1	12.8	Nail		Complete but encrusted nail. Tapering rectangular section and round head. Roman - PM
1817	Fe	1	17.7	Nail	PM / mod	Large square headed nail / pin.
1817	Fe	1	109	Bar	PM / mod	Large, hooked bar, tapering rectangular section. Uncertain function
1817	Fe	2	22.7	Nail		Two nails with tapering rectangular shanks and rounded heads. Encrusted.
3400	Steel	1	2.3	Nail	mod	Modern stainless steel 2" nail
10900	Fe	1	33	Rod	mod?	Tapered bar, possible large nail shank
12004	Fe	3	78	Wire	C19th	Three sections of double corded, twisted barbed wire. Barbs are encrusted so type cannot be determined. Later 19th century.
12004	Fe	1	270	Handle	PM / Mod	Large, complete vessel handle (fixed). Rounded loop with sub-square terminal attachment plates. Probably 19th century.
13604	Natural	1	2.5	Natural	-	Amorphous stone object, not magnetic

Table 7: Description of metalwork by context

Discussion

- B.7.3 The dated metalwork assemblage comprises mostly fragmentary iron objects of later post-medieval or early modern, generally 19th-century, date. The single lead alloy object may just be a piece of scrap and is undated on its own.
- B.7.4 Notable finds include a complete vessel handle (fixed) recovered from Trench 120. The handle has a rounded loop with in-turned necks and sub-square terminal attachment plates. The loop of the handle has raised outer edges/recessed central groove. Although it is unclear what type of vessel this may have been attached to (an iron cooking vessel is a possibility), it is no earlier in date than the 19th century.

- B.7.5 In addition to the vessel handle, three sections of barbed wire of a type introduced in the last quarter of the 19th century were also recovered from Trench 120.
- B.7.6 Other identifiable finds include a fragment of a probable horseshoe from Trench 18. No nail holes are visible on the fragment, although it is heavily encrusted. If this is a horseshoe fragment, it is likely to date to 1600-1900.
- B.7.7 A modern stainless steel two-inch nail was recovered from the topsoil of Trench 34.

Recommendations regarding the conservation, discard, and retention of material

- B.7.8 The assemblage is small and generally of either indeterminate or early modern date. X-radiography may help to determine and clarify the form and function of several objects, so the entire assemblage should be retained at this time. This recommendation could be reconsidered after a review of X-radiographed material.

B.8 Glass

By Anni Byard

Introduction

- B.8.1 Seventeen shards of glass (330g) were recovered from three contexts from three trenches (Table 8). The assemblage is of late 19th and 20th century date.
- B.8.2 The glass was scanned and, where possible, century or broad period dates were assigned. Shards were quantified by count and weight by context and recorded on a spreadsheet.

Description

Context	Count	Weight (gms)	Object	Date	Description
2204	1	231	Juice bottle	1960s	Complete, machine moulded orange juice drink bottle, labelled 'Sun-Up'
10204	8	55	Bottle	20th century	Light brown coloured beer or wine bottle.
13504	8	44.9	Bottle	Late 19th Century	Several refitting pieces from the neck and rim of a bottle. Dark olive green with tapered collar with ring applied finish. Ribbing down neck. Mid - late 19th century or later.

Table 8: Description of glass by context

- B.8.3 A complete, machine-moulded orange juice drink bottle, labelled with the 'Sun-Up' brand name and logo, was recovered from Trench 22. The labelling has faded to white but would have been red originally. This brand was current during the 1960s.
- B.8.4 Eight shards from the same light brown beer or wine bottle were recovered from Trench 102. The bottle is likely to be of 20th-century date.
- B.8.5 The glass fragments from Trench 135 are from the neck and finish (lip) of a dark, olive green bottle of mid to late- 19th century date. Some of the fragments re-fit. The bottle has an applied finish in the form of a tapered collar with ring. Ribbing down neck indicates this bottle was probably made in a mould.

Recommendations regarding the conservation, discard, and retention of material

- B.8.6 Preliminary research into the 'Sun-Up' orange bottle demonstrates that it is an unusual survival, and it should therefore be retained. The remaining glass is of modern date and offers little potential to inform subsequent works, so it can be discarded.

B.9 Clay Tobacco Pipe

By John Cotter

Introduction and methodology

- B.9.1 Two pieces of clay tobacco pipe, weighing 22g, were recovered from two contexts. Given the small amount, this has not been separately catalogued but is fully described below.
- B.9.2 For the London area, pipe bowls are assigned form codes based on Atkinson and Oswald's (1969) London pipes typology, with bowl types assigned to an abbreviated code (eg AO22).

Description

- B.9.3 **Context (1804) Spot date: c 1680-1710.** Description: 1 piece (weight 20g). A complete heeled bowl of London type AO20. Milled around the back third of the bowl. Short length of stem attached. Unburnished. Fresh condition.
- B.9.4 **Context (12004) Spot date: Late 18th to 19th century.** Description: 1 piece (weight 2g). Stem fragment (length 34mm). Slender with narrow stem bore. Traces of the bowl neck at one end, showing traces of ribbed or fluted decoration that would have extended all over the bowl. Fairly fresh condition.

Recommendations regarding the conservation, discard and retention of material

- B.9.5 The pipe fragments have some potential for further study and should therefore be retained.

B.10 Stone

By Ruth Shaffrey

- B.10.1 A total of 13 pieces of stone were retained and submitted for analysis. These were examined with a x10 magnification hand lens for signs of use. Worked or utilised items were recorded, and details entered into a Microsoft Excel spreadsheet.
- B.10.2 Two fragments of Mayen lava were recovered from contexts 1909 (3g) and 11203 (62g), and context 21909 contained three very small fragments of lava. These fragments are all too degraded for anything to be said about their form, but as Mayen lava is only known to have been imported for use as rotary querns, it is assumed that this was their function. These were first introduced to Britain at the time of the Roman conquest in AD 43 and were widely used thereafter, but Saxon or medieval dates are also possible (Hansen 2009). The fragments in context 21909 were accompanied by medieval pottery.
- B.10.3 A large piece of unworked local stone was found in context 20308. This context also contained a flint cobble with rubbed wear across one end, which was associated with prehistoric flintwork of Beaker/early Bronze Age date.
- B.10.4 All the other stone is unworked and unused. The unworked pieces can be discarded, but the Mayen lava fragments should be retained in case of future geochemical or petrographic analysis. The rubber should be retained.

B.11 Slag

By Edward Biddulph

- B.11.1 Three pieces of smithing slag, weighing 88g, were recovered from context 18521, the upper fill of pit 18519 in Trench 185 that produced medieval pottery.
- B.11.2 The assemblage has limited research potential and can be discarded.

C.1 Environmental Samples

By Richard Palmer

Introduction

- C.1.1 Twenty-nine bulk samples were taken as part of the evaluation at Land West of North Ockendon, Lower Thames Crossing, primarily for the retrieval and assessment of Charred Plant Remains (CPR) and the recovery of bones and artefacts with the aim of establishing levels of preservation and significance.

Method

- C.1.2 The samples were processed in their entirety at Oxford Archaeology using a modified Siraf-type water flotation machine. The flots were collected in a 250µm mesh and residues in a 500µm mesh and dried. The residue fractions were sorted by eye and with the aid of a magnet while the flot material was sorted using a low power (x10) binocular microscope to extract cereal grains and chaff, smaller seeds and other quantifiable remains.
- C.1.3 Charcoal identifications were made using a high power (x50 to x400) microscope to identify diagnostic features.
- C.1.4 Nomenclature for identified species follows (Stace 2010). Cereal and chaff identifications are made with reference to Jacomet (2006) and charcoal identifications with reference to Schweingrüber (1990).

Results

- C.1.5 A summary of the samples and flot abundance data is presented in Table 9.
- C.1.6 **Trench 12.** Sample 7 from fill 1213 of pit 1212 produced a large charcoal rich flot. Several species are present including hazel (*Corylus avellana*), alder (*Alnus* sp.) field maple (*Acer campestre*) and oak (*Quercus* sp.). Burnt flint and fired clay were recovered from the residue.
- C.1.7 **Trench 15.** Sample 1 from fill 1503 of pit 1502 produced a large flot. Some of the charcoal is diffuse porous. Most of the grain is damaged and fragmented but the more complete specimens could be identified as wheat (*Triticum* sp.). Pottery and fired clay were recovered from the residue.
- C.1.8 **Trench 20.** Sample 6 from fill 2005 of pit 2004 produced a charcoal rich flot. Charcoal includes oak and apple/hawthorn (Maloideae). Burnt flint was recovered from the residue.
- C.1.9 **Trench 34.** Sample 5 from fill 3403 of pit 3402 produced a charcoal rich flot. Burnt flint was recovered from the residue along with calcined bone.
- C.1.10 **Trench 47.** Sample 4 from fill 4703 of pit 4702 produced a large flot. Recovered grain is in poor condition with many indeterminate fragments. Identifiable specimens are wheat and there is a possibility that barley (cf. *Hordeum vulgare*) is also present. A dock seed (*Rumex* sp.) was also identified. Burnt flint and fired clay were recovered from the residue.

- C.1.11 **Trench 97.** Sample 2 from fill 9706 of cut 9702 produced a poor flot. All recovered material was <4mm in maximum dimension and the only identified charred seed was speedwell (*Veronica* sp.). No finds were recovered from the residue.
- C.1.12 Sample 3 from fill 9707 of pit 9703 produced a small charcoal dominated flot. No finds were recovered from the residue.
- C.1.13 Excavation of a block lifted pot (SF 1) from pit 9704 produced four additional samples from fill 9705 covering exterior spits (9-11) and interior fill (12). All the flots are small with limited quantities of charcoal. Sample 10 has an indeterminate charred fragment, possibly part of a large legume, and some speedwell seeds (*Veronica* sp.) are present in sample 11. Three pottery fragments were recovered from samples 11 and 12.
- C.1.14 **Trench 114.** Sample 8 from fill 11404 of pit 11403 produced a large charcoal rich flot. The charcoal is dirty/has surface staining, but this will not hinder further identification work and oak, field maple and alder (*Alnus* sp.) are present. Burnt flint and fired clay were recovered from the residue.
- C.1.15 **Trench 131.** Sample 13 from fill 13105 of pit 13104 produced a small flot with most of the charcoal extracted from the residue (heavy fraction). Wheat and a possible legume fragment were identified with burnt flint also being recovered from the residue.
- C.1.16 **Trench 138.** Sample 17 from fill 13808 of posthole 13807 produced a small flot with most of the charcoal extracted from the residue, along with some pottery.
- C.1.17 **Trench 151.** Sample 30 from fill 15105 of ditch 15104 produced a modest flot. Grain is a mix of wheat and oat (*Avena sativa*) and half of charred a legume with a diameter of 5mm is also present. Pottery was recovered from the residue.
- C.1.18 **Trench 152.** Sample 28 from fill 15204 of 'natural feature' 15203 produced a charcoal-rich flot. Most of the charcoal, which includes oak, was extracted from the residue and had moderate levels of vitrification. There may be potential for further analysis of the charcoal from this sample. Fired clay was recovered from the residue.
- C.1.19 **Trench 161.** Sample 27 from fill 16103 of ditch 16102 produced a modest flot. Only a single, incomplete, grain is present in the flot together with some charred goosefoot seeds (*Chenopodium* sp.). Burnt flint was recovered from the residue.
- C.1.20 Sample 29 from fill 16110 of stakehole 16109 produced a poor flot. No artefacts were recovered from the residue.
- C.1.21 **Trench 185.** Sample 31 from fill 18517 of pit 18516 produced a poor flot and no artefacts were recovered from the residue.
- C.1.22 Sample 32 from fill 18509 of pit 18508 produced a good-sized flot. Roundwood is present amongst the charcoal and the charcoal includes oak. The grain is mostly wheat but most specimens are damaged, possibly due to collapse after sprouting but no sprouts were identified so this is unconfirmed. Other charred material includes legumes and dock seeds. Pottery was recovered from the residue.
- C.1.23 Sample 33 from fill 18505 of pit 18504 produced a good-sized flot. As with sample 32 the wheat is damaged some of which could be due to sprouting but again this could not be verified. Some possible oat (*Avena* sp.) grains are also present in this assemblage. Charred weed seeds include dock, bedstraws (*Galium* sp.) and

goosefoots. Charcoal includes oak and field maple. Pottery was recovered from the residue.

- C.1.24 **Trench 203.** Sample 18 from fill 20306 of tree-throw 20304 produced a poor flot. Modern, uncharred goosefoots are common in this sample and have not been quantified. No artefacts were recovered.
- C.1.25 **Trench 213.** Sample 20 from fill 21308 of pit 21305 produced a large charcoal rich flot. The non-charcoal component includes encrusted charred wheat grains, legume halves and a small mix of charred weed seeds. These include dock, sedges (*Carex* sp.) and knotgrass (*Polygonum aviculare*). Several charcoal fragments were identified, and all are oak. Flint was recovered from the residue.
- C.1.26 **Trench 214.** Sample 26 from fill 21407 of tree-throw 21405 produced a modest flot. The recorded chaff is a charred rachis fragment, and a charred bedstraw is also present. Pottery was recovered from the residue.
- C.1.27 **Trench 216.** Sample 21 from fill 21612 of pit 21610 produced a poor flot. Most of the charcoal was hand recovered from the residue which produced no artefacts.
- C.1.28 **Trench 217.** Sample 19 from fill 21708 of pit 21706 produced a poor flot. The few wheat grains recovered are damaged which hindered identification of several and a significant portion of the flot consists of uncharred modern plant debris and seeds. No artefacts were recovered from the residue.
- C.1.29 **Trench 218.** Sample 22 from fill 21808 of posthole 21807 produced a poor flot with most charcoal hand recovered from the residue with no artefacts recovered.
- C.1.30 **Trench 220.** Sample 24 from fill 22008 of ditch 22007 produced a poor flot. Possible charred wheat and oat grains are present along with a possible legume. The weed count in Table 9 corresponds almost exclusively to goosefoot seeds. Several were checked and while some appeared modern this may not be representative of the full assemblage given that a few could also be categorised as indeterminate following Mueller-Bieniek *et al.* (2020). At this stage none of the goosefoot seeds was confirmed as charred. Burnt flint was recovered from the residue.
- C.1.31 Sample 25 from fill 22016 of pit 22014 produced a large charcoal-rich flot. Some fragments were identified with the majority being oak and field maple is also present. Burnt flint and pottery were recovered from the residue.

Discussion

- C.1.32 In general, there is potential for the recovery of charred material on site. Condition of the recovered material appeared variable but, in most cases, this was not a hindrance to identification. At this stage dated samples are mainly prehistoric with indications of Roman and medieval activity. Most of the grain was recovered from samples with either an early medieval or medieval date. Sample 4 also produced a good quantity of grain, albeit in fairly poor condition, with a possibly different makeup to those that have been dated.
- C.1.33 Only a small quantity of botanical remains and no faunal remains or other significant material were recovered from the interior of pot SF 1 found inverted in pit 9704. These remains are unlikely to relate to the use or burial of the pot and it is most likely that the soil from the vessel fill is part of the general pit backfill. This conclusion is

supported by the fact that the samples from within the vessel were compositionally similar to those from the outside.

C.1.34 Several samples are charcoal rich and initial examination indicates a mix of species present so full analysis on several of these samples would be worthwhile should subsequent fieldwork be undertaken at this location. Some fragments did show moderate to high levels of vitrification which may obscure diagnostic features.

C.1.35 The wheat in samples 32 and 33 may be sprouted and this topic may merit further consideration.

Recommendations for retention/disposal

C.1.36 The flots warrant retention until all works are complete. Retention in the archive would enable further analysis and radiocarbon dating of key samples should this be required.

Sample no.	Context no.	Feature/Deposit	Date	Sample vol. (L)	Flot vol. (ml)	Charcoal >2mm	Grain	Chaff	Weeds	Molluscs	Other Charred	Notes
1	1503	1502	Med	40	60	+++	++					10YR 4/3 silty clay
2	9706	9702	LBA/ EIA	1	3	++			+			10YR 4/3 silty clay loam
3	9707	9703		2	10	+++						10YR 4/6 silty clay
4	4703	4702		10	50	+++	+++		+			10YR 4/4 silty clay
5	3403	3402		20	40	+++				+		10YR 4/6 sandy silt loam
6	2005	2004	Med/ PMed	8	30	++++						10YR 4/4 silty clay
7	1213	1212		36	50	++++						10YR 4/4 silty clay loam
8	11404	11403		40	180	++++						10YR 3/2 and 10YR 5/2 silty clay
9	9705	9704	LBA/ EIA	1	10	+++						7.5YR 4/6 sandy loam
10	9705	9704	LBA/ EIA	1	5	++					+	7.5YR 4/6 sandy loam
11	9705	9704	LBA/ EIA	8	5	++			+			7.5YR 4/6 sandy loam
12	9705	9704	LBA/ EIA	0.75	2	++						7.5YR 4/6 sandy loam
13	13105	13104		32	5	+++	+				+	Mid grey brown clayey silt
17	13808	13807	Prehist	2	4	+++						Mid grey brown clayey silt
18	20306	20304	Prehis	32	12		+					Mid orangey brown sandy silt

Sample no.	Context no.	Feature/Deposit	Date	Sample vol. (L)	Flot vol. (ml)	Charcoal >2mm	Grain	Chaff	Weeds	Molluscs	Other Charred	Notes
19	21708	21706		30	25	++	+			+		Mid grey brown sandy silt
20	21308	21305		36	150	++++	++		++		+	Mid orangey brown sandy silt
21	21612	21610	RB	27	12	++						Mid grey brown clayey silt
22	21808	21807		8	10	++						Mid grey brown sandy silt
24	22008	22007		24	10	++	+		++++		+	Mid grey brown clayey silt
25	22016	22014	LBA-IA	36	150	++++						Mid orangey brown sandy silt
26	21407	21405	MBA-IA	31	25	+++		+	+	+		Mid grey brown sandy silt
27	16103	16102	IA	24	25	+++	+		++			Light orange brown sandy silt
28	15204	15203		12	25	++++			+			Mid greyish brown sandy silt
29	16110	16109		2	10	++			+			Mid grey brown sandy silt
30	15105	15104	Med	32	20	+++	++		+		+	Mid grey brown sandy silt
31	18517	18516		32	16	++			+			Mid greyish brown sandy silt
32	18509	18508	EMed	28	60	++++	+++		+		+	Mid brownish grey sandy silt
33	18505	18504	EMed	26	50	++++	++++		++			Dark brown sandy silt

Key: +=present (up to 5 items), ++=frequent (5-25), +++=common (25-100), ++++=abundant (100+)

Other charred covers fruit/nut and legume

Table 9: Assessment of bulk soil sample flots

C.2 Animal Bone

By Rebecca Nicholson and Adrienne Powell

Introduction and methodology

- C.2.1 A total of 231 animal bone fragments (221 refitted fragments) weighing 5.164kg was recovered from the site, all of which was collected by hand. The bone came from 29 contexts in Trenches 12, 15, 16, 17, 18, 19, 20, 22, 34, 106, 120, 131, 135, 156, 159, 185, 219, 220 and 222. Features on the site were dated based on associated ceramic finds as prehistoric, Roman, medieval, post-medieval and early modern (c 1805-1900), but most of the identifiable bones came from post-Roman contexts (Table 10).
- C.2.2 All material from dated and undated contexts was recorded in full, with the aid of the Oxford Archaeology skeletal reference collection and standard identification guides, using a diagnostic zone system (Serjeantson 1996). Bone condition was recorded on a semi-quantitative scale of 1 (as fresh) to 5 (extremely poor, corroded and crumbly). Where condition was difficult to score (e.g. burnt bone and teeth) condition was recorded as 0. Few bones were complete enough to permit measurement, but where possible these are available in archive and follow von-den Driesch (1976) and Davis (1992). Tooth wear was recorded following Grant (1982) and ages extrapolated following Payne (1973) for caprines (sheep/goat) and O'Connor (1988, 85) for pigs. Full records will be available with the site archive.

Description

- C.2.3 Bone preservation varies depending to some extent on trench and period but is typically fair - good (condition 2-3), with bones in the poorest condition deriving from Trench 106 (condition 5). No burnt bone was recovered.
- C.2.4 Notable elements of the assemblage include a collection of adult cattle and horse metapodials from contexts 1815 and 1817, which are spot dated to c AD 1580-1900 and c AD 1650-1800 respectively. These included one horse metacarpal, one horse metatarsal, six cattle metacarpals and two cattle metatarsals from 1817 (from a minimum of four cattle) plus one horse metacarpal and two cattle metacarpals from 1815. Two of these were complete and measurements have been taken where possible (Table 11). The predominance of metapodials may indicate that they were deliberately collected for some purpose, possibly related to tanning or bone working, although other bones from context 1817 are consistent with general butchery waste.
- C.2.5 Nine bones, all from post-medieval contexts, exhibit chop marks, including a cattle metacarpal from 1815 (bone chopped through at an oblique angle, detaching the distal end) and one from 1817 (small cuts to a metatarsal shaft). A fragment of large mammal long bone from late Bronze Age or Iron Age context 3400 has a knife cut in the inside of the shaft, probably an indication of marrow extraction. Spiral fractures, particularly evident on several long bones from 1817, may also derive from the cracking of bone for marrow.
- C.2.6 A caprine mandible from 1817 has a mandible wear stage of 42 (after Grant 1982), indicative of an older adult animal, of around 5-6 years old, while a caprine mandible from 1705 has a mandible wear stage of 31, indicative of a younger animal of 2-3 years and a caprine mandible from 1804 is from an old adult (4-6 years old, MWS 40). A pig mandible from post-medieval ditch fill 1804 has a mandible wear stage of 34-36 indicative of an old animal, while an erupting M3 in a fragment of jaw from

medieval context 1603 indicates an immature pig and is consistent with the usual age of slaughter of this animal for meat.

- C.2.7 Dog was only identified from a small radius fragment (context 1508) but gnaw marks probably inflicted by dogs are present on bones from several contexts and are particularly concentrated at the ends of long bone shafts.
- C.2.8 A small group of articulating cattle bones, consisting of the fifth and sixth lumbar vertebrae and the first sacral vertebra, was recovered from undated ditch fill 15604.
- C.2.9 An unworked fragment of red deer antler with attached pedicle was recovered from medieval ditch fill 1603.
- C.2.10 Apart from red deer, bones from wild animals are confined to a hare tibia from 1809 as well as two rook bones (tibia and ulna) from 12004, which has been dated to the 19th century. The only other bird bone is a large domestic fowl proximal tibiotarsus from post-medieval ditch fill 1909.

	LBA /IA	Iron Age	Roman	Medieval	Post-medieval	Early modern	Undated	Total
Cattle			1	1	28		8	38
Horse				1	3		1	5
Sheep/goat					9	1		10
Pig				1	4			5
Red deer*				2				2
Dog				1				1
Hare					1			1
Large mammal	1			16	44			61
Medium mammal				1	2		2	5
Mammal				13	22		1	36
Domestic fowl					1			1
Rook						2		2
Unidentified		2		14	11		27	54
Total	1	2	1	50	125	3	39	221

*=antler fragments

Table 10: Animal bone: number of Identified Specimens by period

Context	Taxon	Element	Side	GL	Bp	SD	Bd	BT	HT	HTC
1817	Cattle	Metatarsal	left	206	44.9	24.6	49.0			
1817	Cattle	Metacarpal	right				64.5			
1817	Cattle	Metatarsal	left				49.2			
1815	Horse	Metacarpal	left	225	47.5	33.6	48.0			
15904	Cattle	Humerus	left					71.3	41.5	29.5
22204	Cattle	Metacarpal	right	186.5		28.8	52.8			

Table 11: Cattle and horse measurements (mm)

Conclusions

- C.2.11 Bone is clearly present in the areas excavated and is generally fairly well preserved. The collection of cattle and horse metapodials from ditch fills in Trench 18 may relate to some industrial or craft function.

C.2.12 The assemblage has been fully recorded, and while little can be read into such a small assemblage the results would be worth considering alongside any future excavations at the site.

Recommendations regarding the conservation, discard and retention of material

C.2.13 The bone has been fully recorded and has limited additional research value except perhaps some tentative association with the function of post-medieval buildings in the vicinity of the site. As such, the assemblage is not considered to be a high priority for retention in the archive, although the metapodials from 1815 and 1817 may be worth retaining to contribute to future additional biometric analysis of post-medieval cattle and horses.

C.3 Shell

By Rebecca Nicholson

Introduction and methodology

- C.3.1 Eleven fragments of marine shell weighing 171g in total were recovered through hand excavation. Table 12 provides details of the assemblage by context. Descriptions of epibont damage and chalky deposits are based on Winder (2011).

Description

- C.3.2 The shell is mostly in fair or good condition and all is European flat oyster (*Ostrea edulis*). The shells are mostly of the typical rounded shape for the species but hinge shape and size is varied. A small number of shells have evidence of tunnels caused by a bristleworm, probably *Polydora ciliata* and one has a sub-rectangular perforation which may have been caused by a metal pronged rake used to when gathering the oysters.
- C.3.3 The shells come from ditch fills in Trenches 17, 18 and 19, all of which have been dated as late medieval or post-medieval.
- C.3.4 The small numbers of shells collected from this evaluation precludes further analysis, but demonstrates that marine shell is preserved in some areas at least and includes well preserved and complete examples.

Recommendations regarding the conservation, discard and retention of material

- C.3.5 The shell has been recorded and is not considered to have any significant additional research value. Consequently, retention in the archive is not recommended and the assemblage may be discarded.

Context	Count	Weight (g)	No. oyster left valves	No. oyster right valves	Notes
1705	6	59	1	5	Small valves, fair condition and mostly complete. One right valve has evidence of <i>Polydora ciliata</i> tunnelling externally while another has slight traces of sponge boring (eg by <i>Ciona celata</i>). One right valve has an opening notch. The small left valve has a sub-rectangular perforation in the middle of the shell, as well as internal blistering.
1817	4	65	1	3	Small and fairly large valves. Left valve is fairly large, lobed and almost complete. Two right valves (one fairly large, 1 small) have evidence of <i>Polydora ciliata</i> tunnelling externally while the other right valve has another left valve of similar size adhering.
1909	1	47	1	0	One large left valve, almost complete with possible slight trace of <i>Polydora ciliata</i> tunnelling externally and a chalky deposit and flaking surface internally.

Table 12: Summary of shell assemblage

C.4 Human Remains

By Mandy Kingdom

Introduction and provenance

- C.4.1 A small deposit of calcined bone (3403) was recovered during the evaluation. The deposit was part of a charcoal-rich fill within possible pit 3402, located in the south-east corner of evaluation Trench 34.
- C.4.2 Pit 3402 was an irregular ovoid feature measuring approximately 1.12m at its widest point, with undercut sides and a total depth of 0.16m. The irregular shape of the pit, its concave uneven base, and evidence of root activity suggest the feature was a possible tree-throw hole and was natural in origin. Deposit 3403 was 0.16m deep and comprised charcoal-rich, soft, sandy silt with occasional burnt bone fragments. It was overlain by ploughsoil (3400), suggesting that it may have been truncated or disturbed.
- C.4.3 No dating evidence was recovered from deposit 3403, and it cannot be associated with any other dated material. The deposit is, therefore, undated.

Methodology

- C.4.4 Deposit 3403 was recovered, processed and analysed in accordance with published guidelines (McKinley 2004). The deposit was subject to whole earth recovery (as bulk soil sample 5) in the field, before being processed and analysed.
- C.4.5 Processing involved wet sieving the deposit, which sorted it into fractions of >10mm, 10-4mm, 4-2mm and 2-0.5mm. The >10mm, 10-4mm and 4-2mm fractions were fully sorted to separate the burnt bone from the extraneous material (eg stones). No burnt bone was present within the >10mm fraction. The smallest fraction size (2-0.5mm) was rapidly scanned for identifiable skeletal remains and artefacts.
- C.4.6 All bone within each sieve fraction was analysed to record weight, maximum fragment size, types of bone present, colour and the presence of pyre and/or grave goods. As bone was not sorted from the 2-0.5mm fraction, the proportion of bone present was estimated visually instead. This has not been included in the total deposit weight.
- C.4.7 Bone was also examined to explore the minimum number of individuals present (MNI) and any evidence for pathology, trauma and non-metric traits. Estimations of sex and age were not possible due to the absence of any identifiable fragments or diagnostic features.

Results

- C.4.8 A summary of the osteological findings is presented in Table 13.

Context	>10mm	10-4mm	4-2mm	Total weight	Maximum fragment size	Identified elements	MNI/Age/Sex/Other observations
3403	0g	2.1g	3.1g	5.2g	13mm (possible long bone fragment)	None present	MNI: 1 Sex: unknown Age: unknown Pathology: None Non-metric traits: None

Table 13: Summary of osteological findings

Bone Weight

- C.4.9 At 5.2g, the total weight of deposit 3403 falls significantly below the expected range for both modern (1000-2400g, with an average of 1650g, McKinley 2000a, 269) and archaeologically recovered cremation deposits (600-900g, McKinley 2013, 154). The 2-0.5mm unsorted residue weighs a total of 741g, but the cremated bone content is very low at no more than around 2-3% (by volume), so would have added very little to the total bone weight.

Fragmentation

- C.4.10 The largest proportion of bone from deposit 3403, representing over half of the total bone weight (59.6%, 3.1g/5.2g), is from the 4-2mm sieve fraction.
- C.4.11 The largest bone fragment in the deposit is a piece of possible long bone diaphysis measuring 13mm.

Skeletal Representation

- C.4.12 Due to the small amount of bone present (5.2g) and the high degree of fragmentation, it was not possible to identify any of the fragments to a skeletal element or region. The density and morphology of the fragments observed are consistent with that of calcined human bone (probable unidentified long bone fragments), rather than burnt non-human animal bone.

Colour of the cremated bone

- C.4.13 The colour of cremated bone reflects the degree of oxidation and is therefore an indication of the efficiency of the cremation, in terms of the quantity of fuel used to build the pyre, the temperature attained in various parts of the pyre and the length of time over which the cremation was undertaken (McKinley 2004, 11). Colour may range from brown/orange (unburnt) to black (charred: c 300°C), through hues of blue and grey (incompletely oxidised, up to c 600°C) to white (fully oxidised, >600°C; *ibid.*).
- C.4.14 The burnt bone from deposit 3403 is white and therefore fully oxidised, indicating an attained temperature of >600 °C. Black staining resulting from the charcoal-rich fill was noted on the surface of a few small fragments.

Demography

- C.4.15 The bone fragments present lack features that would allow the minimum number of individuals (MNI) to be explored by recording the presence, absence and repetition of skeletal elements (as described by Buikstra and Ubelaker 1994, 9). It is therefore assumed the deposit represents at least one individual based on the fact that it derives from one feature.
- C.4.16 As noted above, it was not possible to estimate sex or age due to the absence of any identifiable fragments.

Pathology and non-metric traits

- C.4.17 No pathology, trauma or non-metric traits were observed.

Pyre/grave goods

- C.4.18 No pyre or grave goods were observed. No staining or residue, indicative of pyre/grave goods, were observed.

Discussion

- C.4.19 The deposit recovered from pit 3402, excavated in Trench 34, included small fragments of calcined bone whose density and morphology were consistent with that of human skeletal remains. These represent the partial remains of at least one individual. Due to the small number and size of the fragments, no demographic information could be ascertained.
- C.4.20 The deposit is extremely small, weighing just 5.2g, which is significantly below the expected range (600-900g) for archaeologically recovered adult cremation burials (McKinley 2013, 154). As the deposit was overlain by ploughsoil (3400), it is possible that it had been truncated/disturbed by past agricultural activity and therefore is only a portion of the material originally deposited. Low bone weights are a common finding in archaeological cremation deposits and may be defined as cremation-related deposits rather than formal cremation burials (McKinley 2004, 9). Such deposits might represent cenotaph burials, where only a token amount of bone was deposited (McKinley 2000b, 42-3), or redeposited pyre debris, which generally comprises a mixture of bone fragments and fuel waste (McKinley 2004, 10). As charcoal was noted during the excavation of 3403, and a small amount of black surface staining from contact with the charcoal rich fill was noted during analysis, it is suggested that 3403 represents a pyre debris deposit, rather than a formal cremation burial. Deposits of pyre debris are frequently encountered archaeologically and are not specific to a time period (McKinley 2000b, 41).
- C.4.21 Overall, the bones are white in colour (fully oxidised). This indicates that the corpse would have been placed on the pyre in such a way as to maintain a consistently high temperature and oxygen supply (McKinley 2013, 158), enabling a temperature in excess of 600°C (McKinley 2004, 11). A high proportion of fully oxidised bone is a common observation in archaeological cremation burials (McKinley 2006, 84).
- C.4.22 All osteological information has been obtained from deposit 3403, thus no further work is recommended. Given that the deposit is undated, it would normally be recommended that a sample of bone is submitted for radiocarbon dating. However, the small size and nature of the fragments are insufficient for this type of analysis.
- C.4.23 The assemblage is currently held at Oxford Archaeology under Ministry of Justice burial licence 19-0317. This licence is valid until 08 December 2025, by which time the remains must have been reburied. In the event that the remains are not ready for reburial by this time, the licence should be deferred by application to the Ministry of Justice.

ACBMG, 2007 *Ceramic building material, minimum standards for recovery, curation, analysis and publication*. Retrieved from:

Atkinson, D and Oswald, A, 1969 London clay tobacco pipes, *J Brit Archaeol Ass* **32**, 171-227

Bamford, H, 1985 *Briar Hill: excavation 1974-1978*, Northampton: Northampton Development Corporation Archaeological Monogr **3**

Barton, R N E, and Roberts, A, 2004 The Mesolithic period in England: current perspectives and new research, in *Scotland and its neighbours* (ed. A Saville), *Mesolithic*, Edinburgh: Society of Antiquaries of Scotland, 339-58

BGS, 2020 *Geology of Britain Viewer*, [REDACTED]

Biddulph, E and Brady, K, 2015 *Excavations along the M25: Prehistoric, Roman and Anglo-Saxon activity between Aveley and Epping, Essex*, Colchester: Essex Society for Archaeology and History, Occasional Papers, New Series, no. **3**

Birley, M, 2016 Grooved Ware pottery, in *Lives in the Land. Mucking Excavations by Margret and Tom Jones, 1965-1978: Prehistoric, Context and Summary* (C Evans, G Appleby, and S Lucy, with J Appleby and M Brudenell), Oxbow Books, 71-77

Brown, N, 2016 Earlier/middle Bronze Age pottery, in *Lives in the Land. Mucking Excavations by Margret and Tom Jones, 1965-1978: Prehistoric, Context and Summary* (C Evans, G Appleby, and S Lucy, with J Appleby and M Brudenell), Oxbow Books, 105-110

Brudenell, M, 2016a Late Bronze Age pottery, in *Lives in the Land. Mucking Excavations by Margret and Tom Jones, 1965-1978: Prehistoric, Context and Summary* (C Evans, G Appleby, and S Lucy, with J Appleby and M Brudenell), Oxbow Books, 158-88

Brudenell, M, 2016b Middle Iron Age pottery, in *Lives in the Land. Mucking Excavations by Margret and Tom Jones, 1965-1978: Prehistoric, Context and Summary* (C Evans, G Appleby, and S Lucy, with J Appleby and M Brudenell), Oxbow Books, 365-93

Buikstra, J E, and Uberlaker, D H, 1994 *Standards for data collection from human skeletal remains*, Arkansas: Arkansas Archaeological Survey Research Series **44**

Butler, C, 2005 *Prehistoric flintwork*, Stroud: Tempus

ClfA, 2014a *Code of conduct*, Revised October 2019. Chartered Institute for Archaeologists. Retrieved from: [REDACTED]

ClfA, 2014b *Standard and guidance for archaeological field evaluation*. Updated October 2020. Chartered Institute for Archaeologists. Retrieved from: [REDACTED]

CIFA, 2014c *Standard and guidance for the creation, compilation, transfer and deposition of archaeological archives*. Revised October 2020. Chartered Institute for Archaeologists. Retrieved from: [REDACTED]

Conneller, C, Bayliss, A, Milner, N and Taylor, B, 2016 The resettlement of the British landscape: towards a chronology of early Mesolithic lithic assemblage types, *Internet Archaeology* **42**

Cotter, J P, 2000 *Post-Roman pottery from excavations in Colchester 1971-1985*, Colchester: Colchester Archaeological Report **7**

Davis, S J M, 1992 A rapid method for recording information about mammal bones from archaeological sites, AML Research Report 19/92

Essex County Council, Historic Environment Branch, 2010 *The Greater Thames Estuary Historic Environment Research Framework: Part 1 Update and Revision of the Archaeological Research Framework for the Archaeological Research Framework for the Greater Thames Estuary 1999*, London

Grant, A, 1982 The use of tooth wear as a guide to the age of domestic ungulates, in *Ageing and sexing animal bones from archaeological sites* (eds B Wilson, C Grigson and S Payne), Oxford: BAR Brit. Ser. **109**, 91-108

Hansen, S C J, 2009 Whetstones from Viking Age Iceland as part of the Trans-Atlantic trade in basic commodities. Unpublished MA Thesis, University of Iceland

Healey, E, 2016 Worked flint, in *Lives in the Land. Mucking Excavations by Margret and Tom Jones, 1965-1978: Prehistoric, Context and Summary* (C Evans, G Appleby, and S Lucy, with J Appleby and M Brudenell), Oxbow Books, Oxford, 88-9

Harrison, E, 2000 Pottery and fired clay, in A Late Bronze Age landscape at South Hornchurch, Essex (E Guttman and J Last), *Proc Prehist Soc* **66**, 337-44

Healy, F, 1988 *The Anglo-Saxon cemetery at Spong Hill, North Elmham, part VI: occupation during the seventh to second millennia BC*, E Anglian Archaeology **39**, Norfolk: Norfolk Archaeological Unit

Healy, F, 2020 Struck flint, in *Ceremonial Living in the Third Millennium BC: Excavations at Ringlemere Site M1, Kent, 2002-2006* (K Parfitt and S Needham), British Museum Research Publication **217**, 149-98

- MOLA, 2014a *Roman pottery codes.*, Museum of London Archaeology. Retrieved from: [REDACTED]
- MOLA, 2014b *London medieval and post-medieval pottery codes*, Museum of London Archaeology. Retrieved from: [REDACTED]
- MOLA, 2014c *London medieval and post-medieval ceramic building material codes.*, Museum of London Archaeology. Retrieved from: [REDACTED]
- MOLA, 2014d *London Roman ceramic building materials: fabrics, dating, groups, sources and distribution codes*, Museum of London Archaeology. Retrieved from: [REDACTED] (accessed 12 Feb 2019)
- O'Connor, T P, 1988 *Bones from the general accident site, Tanner Row, The Archaeology of York volume 15/2: the animal bones*, London: Council for British Archaeology
- Oxford Archaeology, 2012 M25 DBFO widening Section 4: post-excavation assessment and project design. Unpublished Oxford Archaeology Rep
- Oxford Archaeology, 2019a Lower Thames Crossing Scheme-wide Written Scheme of Investigation for Trial Trenching south of the River Thames
- Oxford Archaeology, 2019b Lower Thames Crossing Scheme-wide Written Scheme of Investigation for Trial Trenching north of the River Thames
- Oxford Archaeology, 2020 Lower Thames Crossing Scheme-wide Written Scheme of Investigation for Trial Trenching of Land Parcels 40, 49-52
- Palmer, J J, 2019 *Open Domesday*, [REDACTED] University of Hull
- Payne, S, 1973 Kill-off patterns in sheep and goats: the mandibles from Asvan Kale. *Anatolian Studies* **23**, 281-303
- PCRG, SGRP, MPRG, 2016 *A standard for pottery studies in archaeology*. Prehistoric Ceramics Research Group, Study Group for Roman Pottery, and the Medieval Pottery Research Group
- Place Services, 2019 *Lower Thames Crossing aerial investigation and mapping report*, Chelmsford: Essex County Council
- Powell, W R, 1978 *A history of the county of Essex: Victoria County History Volume 7*, London: Oxford University Press
- Serjeantson, D, 1996 Animal bone, in *Runnymede Bridge research excavations, volume 2: refuse and disposal at Area 16 East, Runnymede* (eds S Needham and T Spence), London: British Museum Press, 194-223

Smith, I F, 1965 *Windmill Hill and Avebury: excavations by Alexander Keiller, 1925-1939*, Oxford: Clarendon Press

Tomber, R and Dore, J, 1998 *The National Roman fabric reference collection: a handbook*, London: MOLAS Monograph 2

von den Driesch, A, 1976 *A guide to the measurement of animal bones from archaeological sites*, Cambridge, MA: Harvard University Press

Winder, J M, 2011 *Oyster Shells from Archaeological Sites: a brief illustrated guide to basic processing*



Appendix E Abbreviations and Glossary

ADS Archaeology Data Service. Digital archaeological archive

CBM Ceramic Building Material

CDM Construction Design Manual. Health and safety guidance for the construction industry

CPD Continuing Professional Development

ClfA Chartered Institute for Archaeologists

DBA Desk Based Assessment. Detailed assessment of archaeology and other aspects of the historic environment

DCO Development Consent Order

ECC Essex County Council

EIA Environmental Impact Assessment. Detailed study of environmental impacts as directed under the Town and Country Planning (Environmental Impact Assessment) Regulations 2017 following on from EU Directive EIA Directive (85/337/EEC)

ES Environmental Statement. The principal environmental report detailing environmental impacts within an EIA

GLAAS Greater London Archaeological Advisory Service

GPS Global Positioning System

HER Historic Environment Record

LTC Lower Thames Crossing

MCIfA Member of the Chartered Institute for Archaeologists

MoRPHE Management of Research Projects in the Historic Environment

NMP National Mapping Programme. A study of aerial photographs and digitisation of resulting data into GIS. Originally funded by Historic England

OASIS Online Access to the Index of archaeological investigations. The OASIS project brings together a number of strategic partners: the Archaeology Data Service, Historic England, Historic Environment Scotland, and the Royal Commission on the Ancient and Historical Monuments of Wales under the umbrella of the University of York

OCN Old County Number. Historic England's reference for material that is not readily available online and may represent historic archaeological work that consists of paper archives or has yet to be formally reported on

OS Ordnance Survey

PINS Planning Inspectorate

RAMS Risk Assessment Method Statement

SMC Scheduled monument consent

TDR Trusted Digital Repository

UKIC United Kingdom Institute for Conservation

VCH Victoria County History

WSI Written Project of Investigation. A detailed method statement for archaeological work

WSL Western Southern Link. The Western Southern Link (WSL) is an alternative for Short List Routes 2, 3 and 4 to the south of the River Thames.

Appendix F Site Summary

Site name:	Lower Thames Crossing Land Parcels 40 and 49, North Ockendon
Site code:	OCD20
Grid Reference	NGR 558032 187514
Type:	Evaluation
Date and duration:	22nd September - 6th Nov 2020 and 19th May- 3rd September 2021
Area of Site	c.32ha

Location of archive:

The archive from OCD20 (Land Parcels 40 and 49) will form part of the overall trial-trenching scheme archive. This will be deposited in a repository consistent with the standards required by the Museums and Galleries Commission following completion of the archaeological phase of this project. This may either be with the local or designated receiving museums or, if no such repositories are available, with a repository for the whole project designated by LTC. LTC retain the overall responsibility for the successful deposition of the project archive.

Currently, the archive is held at Oxford Archaeology's head office, Janus House, Osney Mead, Oxford, Oxfordshire, OX2 0ES. Oxford Archaeology will store the archive for LTC for a maximum period of 2 years following the completion of the project. If the storage of the archive at OA's office extends past this period, an extension to the storage period and final deposition timetable will be reviewed by OA and LTC and agreed with the major stakeholders.

Summary of Results:

Oxford Cotswold Archaeology was commissioned by Balfour Beatty to undertake a trial-trench evaluation of Land Parcels 40 and 49 covered by WSI H of the Lower Thames Crossing Pre-Enabling Works. The land parcels are located west of the village of North Ockendon within the London Borough of Havering and the borough of Thurrock, Essex, centred on NGR 558032 187514. A total of 218 trenches were excavated across two separate phases of fieldwork completed between 22nd September to 6th November 2020 and 19th May to 3rd September 2021.

Of the 218 trenches excavated, 99 trenches were found to contain archaeological remains, largely in low density and comprising ditches, pits, postholes and natural features such as tree-throw holes. Concentrations of features were revealed in the north, north-east and south-east of the site.

A microlith attests to definite Mesolithic activity on the site, and a small assemblage of early Neolithic struck flint, together with two sherds of early-middle Neolithic pottery, in the north-west part of the site, suggest activity here. A tree-throw hole contained an assemblage of flakes and scrapers and a utilised pebble dating to the Beaker/early Bronze Age period, indicating an activity area in the south-east part of the site. Two adjacent pits in the centre of Land Parcel 49, one containing a middle Bronze Age Bucket urn, the other a truncated upright vessel, indicate purposeful placed deposits. These were cut into a curving ditch. A pit containing late Bronze Age pottery was found at the south end of the site, and a ditch in the north-east corner of the site may also be of this date. A possible focus of early Iron Age activity was found either side of the railway line in the western part of Land Parcel 49,

including a pit containing a near-complete vessel, and another possible focus that included middle Iron Age pottery at the south end of the site.

Evidence of Roman land use is restricted to small quantities of pottery and ceramic building material, most of which was residual in later features. The small assemblage is suggestive of background activity within the landscape, which may have been related to nearby settlement activity recorded at Manor Farm.

A few sherds of early/mid-Anglo-Saxon pottery indicate a background presence during that period. Activity increased during the medieval period, particularly c 1000-1400. A small number of ditches and pits were perhaps related to agricultural activity, with the pottery assemblages and charred grain indicative of nearby settlements. Medieval remains were concentrated in the west, north and south-east fringes of the site, the first suggesting a focus of activity located along the medieval precursor of Pike Lane adjacent to the site, which may potentially date from the late Saxon period. The last was sited adjacent to activity of 10th-12th century date revealed during earlier excavations during the widening of the M25. The activity to the north dates to later within the medieval period. An assemblage of medieval/post-medieval roof tile and brick also recovered from the northern and south-east areas may indicate that Tudor buildings were located nearby.

Late post-medieval/modern remains were revealed across the site in the form of ditches that correspond with field boundaries depicted on historic Ordnance Survey mapping and residual finds in overburden deposits. These remains are demonstrative of agricultural use of the landscape during this period.

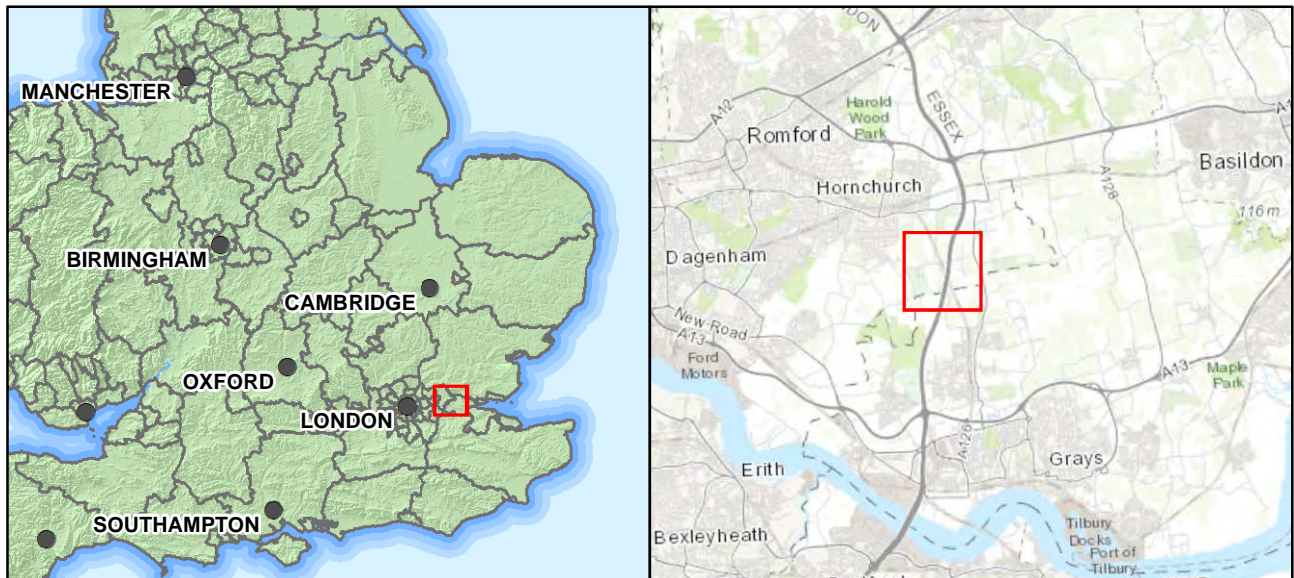

X:\MLTCEV_Lower_Thames_Crossing\010\Geomatics\03 GIS Projects - OCD20_Mo\MLTCEV_Reports\MLTCEV_Report_Fig1.mxd*aidan.farnham*25/11/2021

Source: Esri, Maxar, GeoEye, Earthstar Geographics, CNES/Airbus DS, USDA, USGS, AeroGRID, IGN, and the GIS User Community
Contains Ordnance Survey data © Crown copyright and database right 2016

Figure 1: Site Location

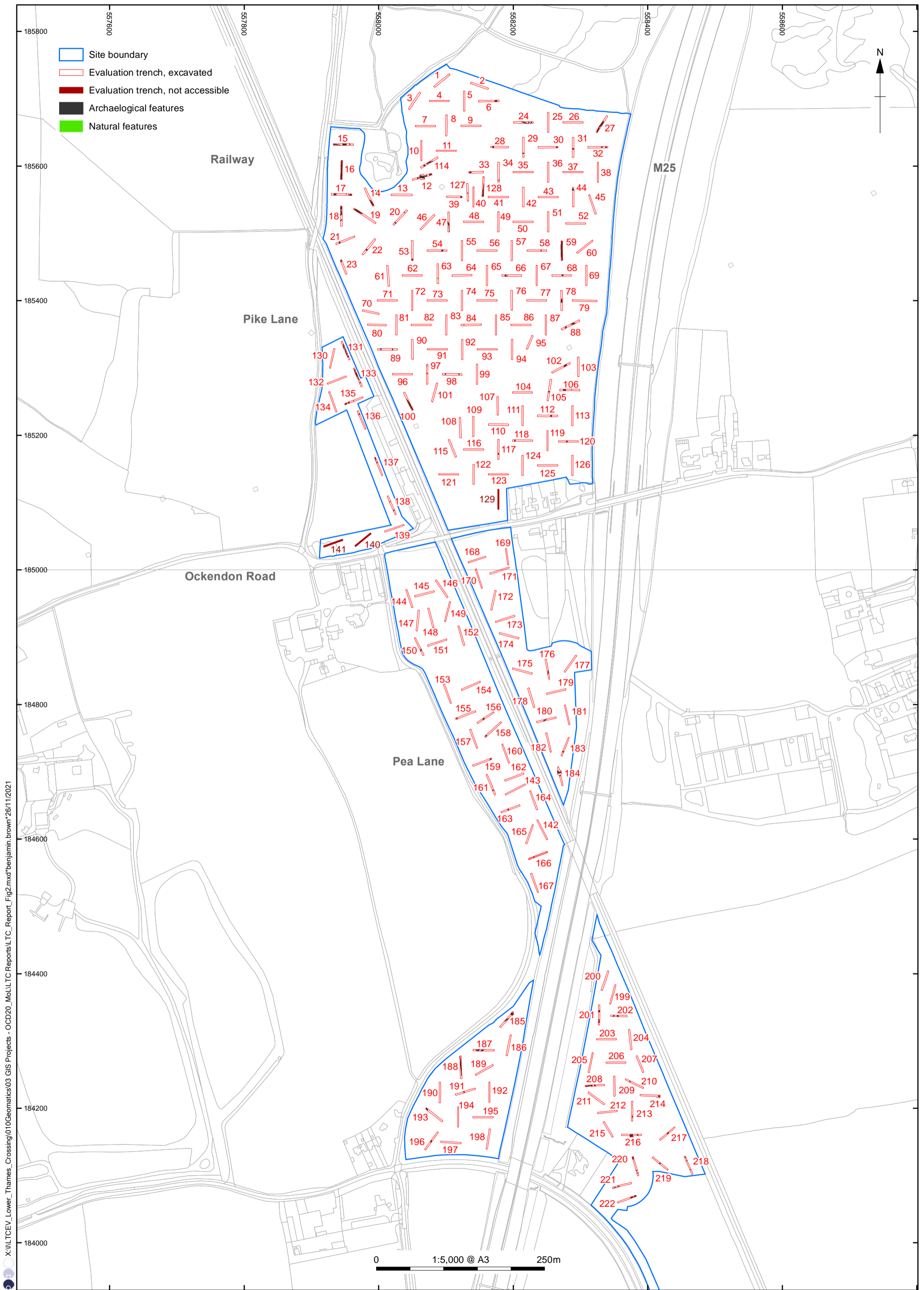

X:\ILTCEV_Lower_Thames_Crossing\010\Geomatics\03 GIS Projects - OCD20_MoLL\TC Reports\TC_Report_Fig2.mxd\benjamin.brown\26/11/2021

Contains Ordnance Survey data © Crown copyright and database right 2020, provided by client

Figure 2 : Plan of trench layout

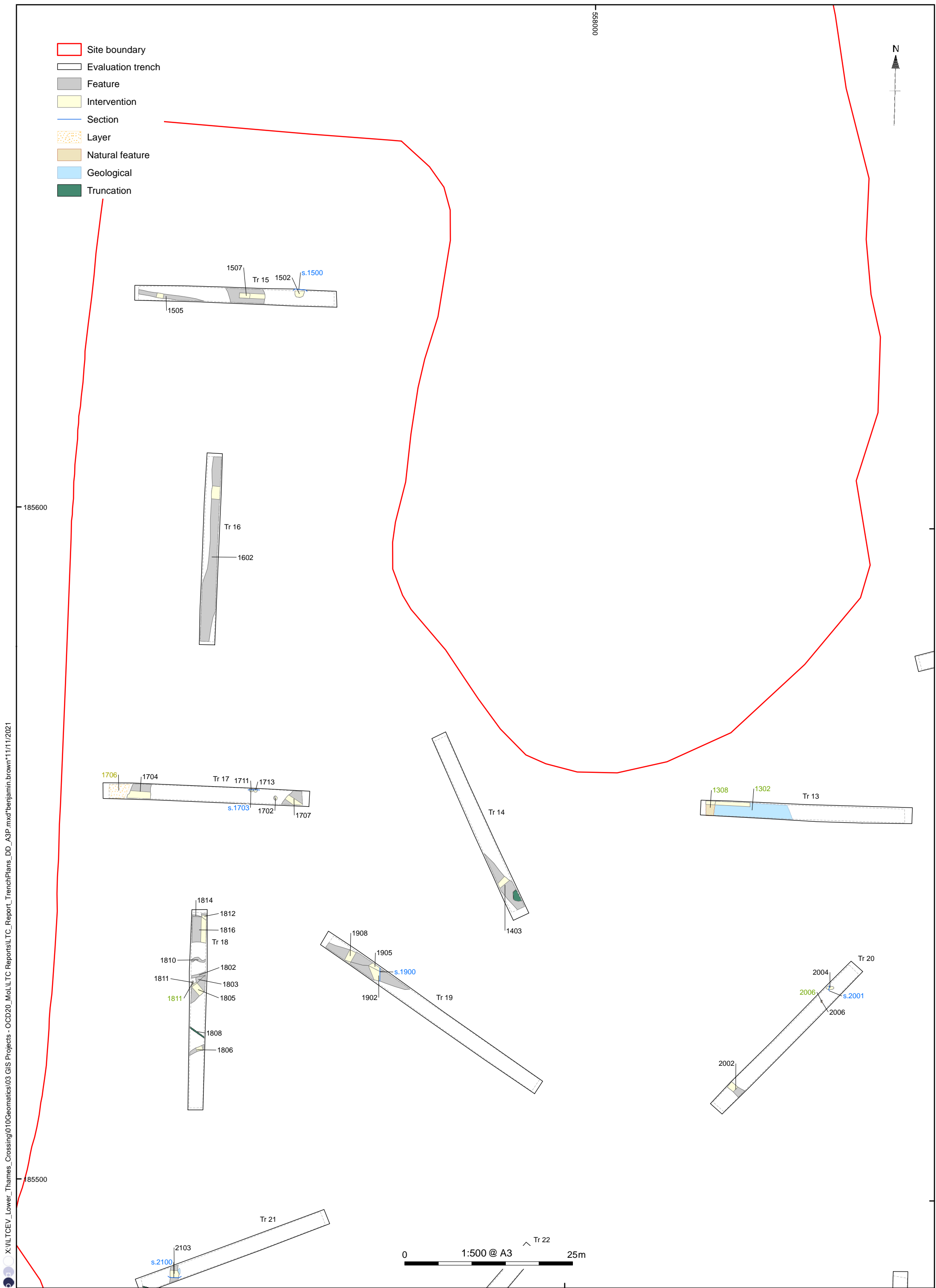

X:\VILTCEV_Lower_Thames_Crossing\010\Geomatics\03 GIS Projects - OCD20_MoL\LC Reports\LC_Report_TrenchPlans_DD_A3P.mxd*benjamin.brown*11/11/2021

Figure 3: Plan of Trenches 13-20

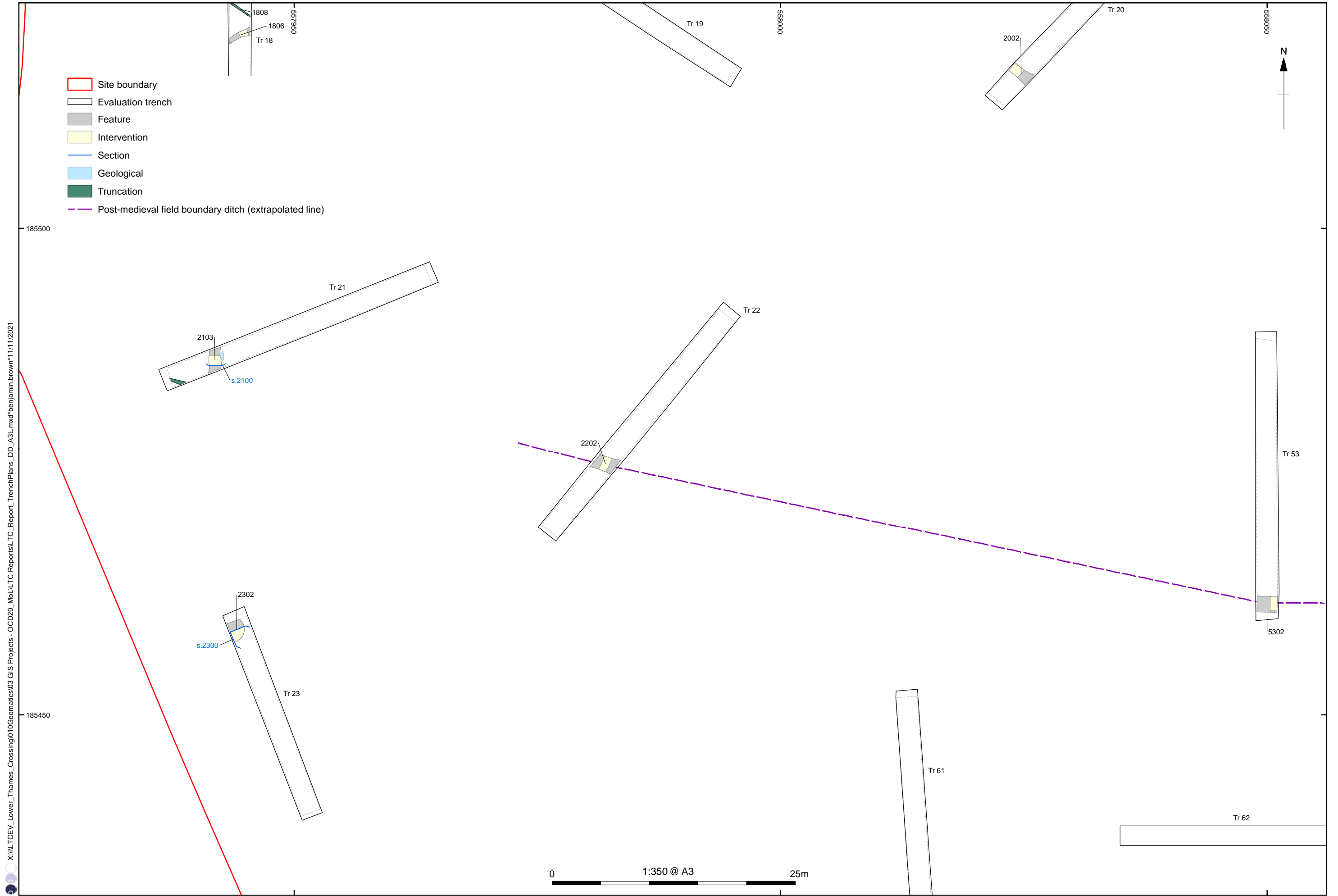

Figure 4: Plan of Trenches 21-23 and 53

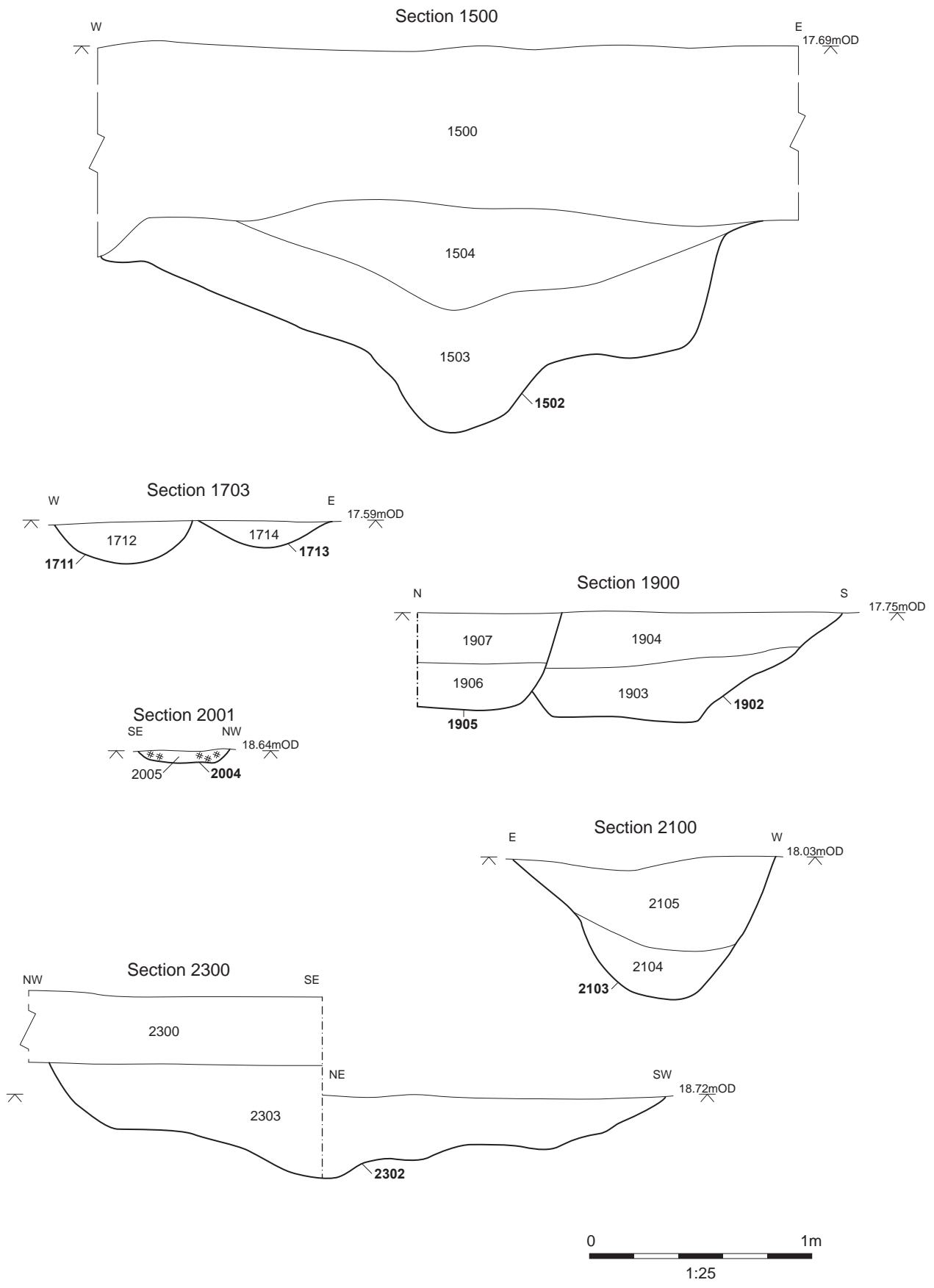

Figure 5: Sections (Trenches 15, 17, 19, 20, 21 and 23)

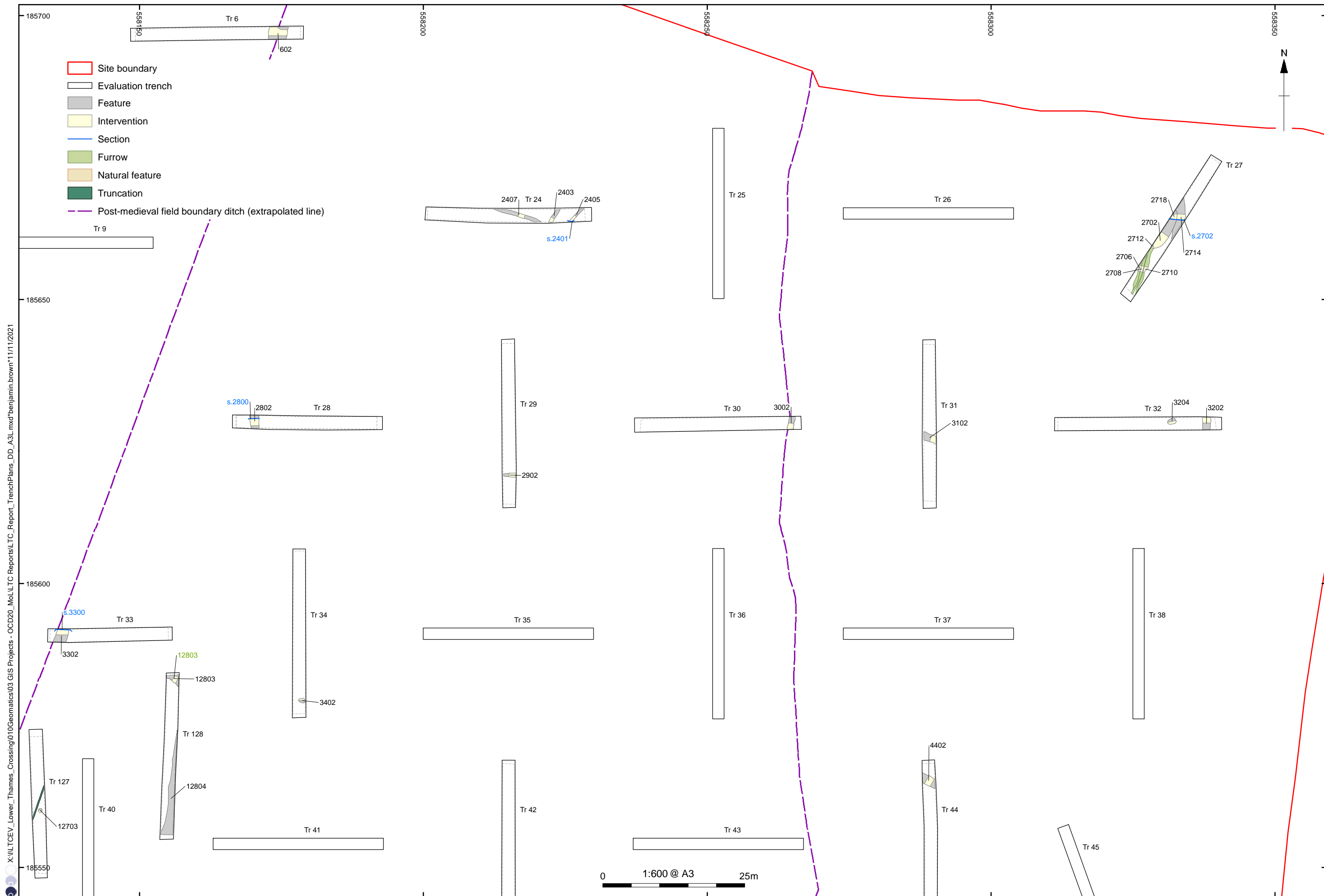

Figure 6: Plan of Trenches 6, 24, 27-32, 34 and 44

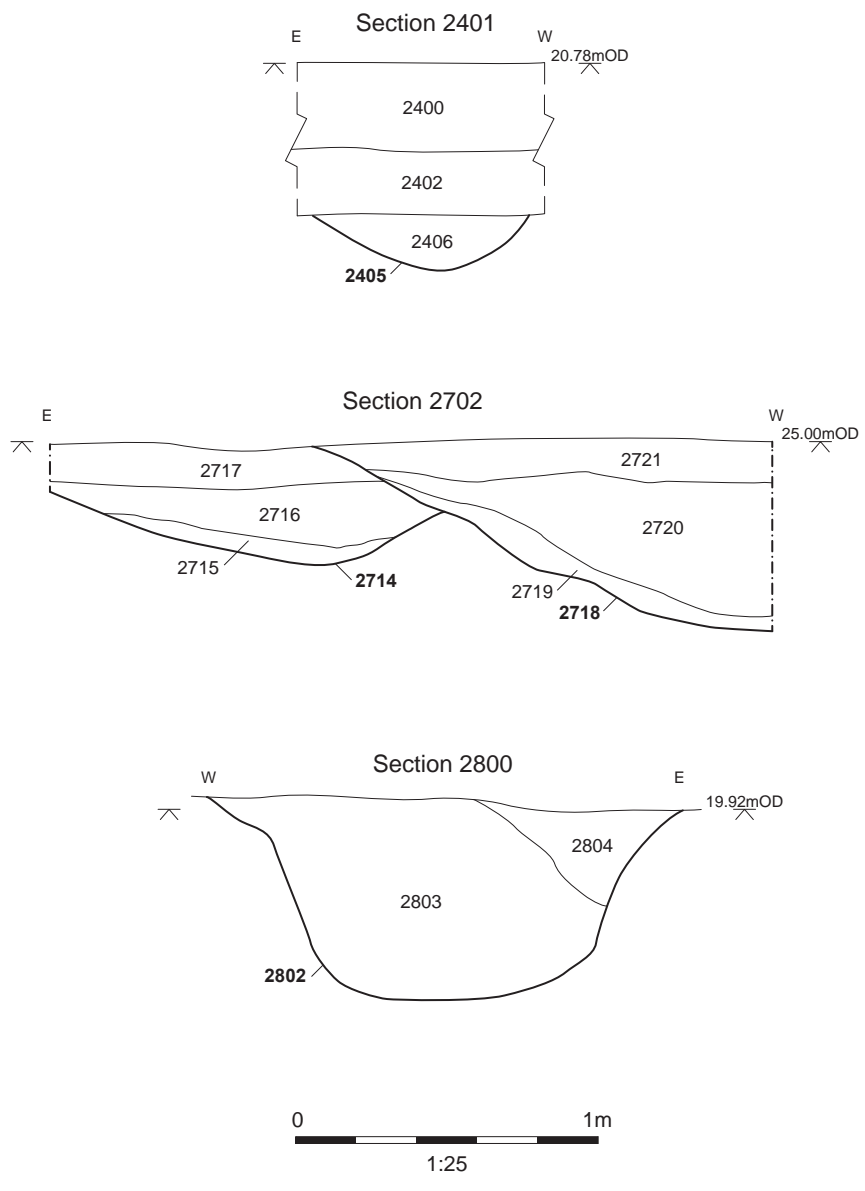

Figure 7: Sections (Trenches 24, 27 and 28)

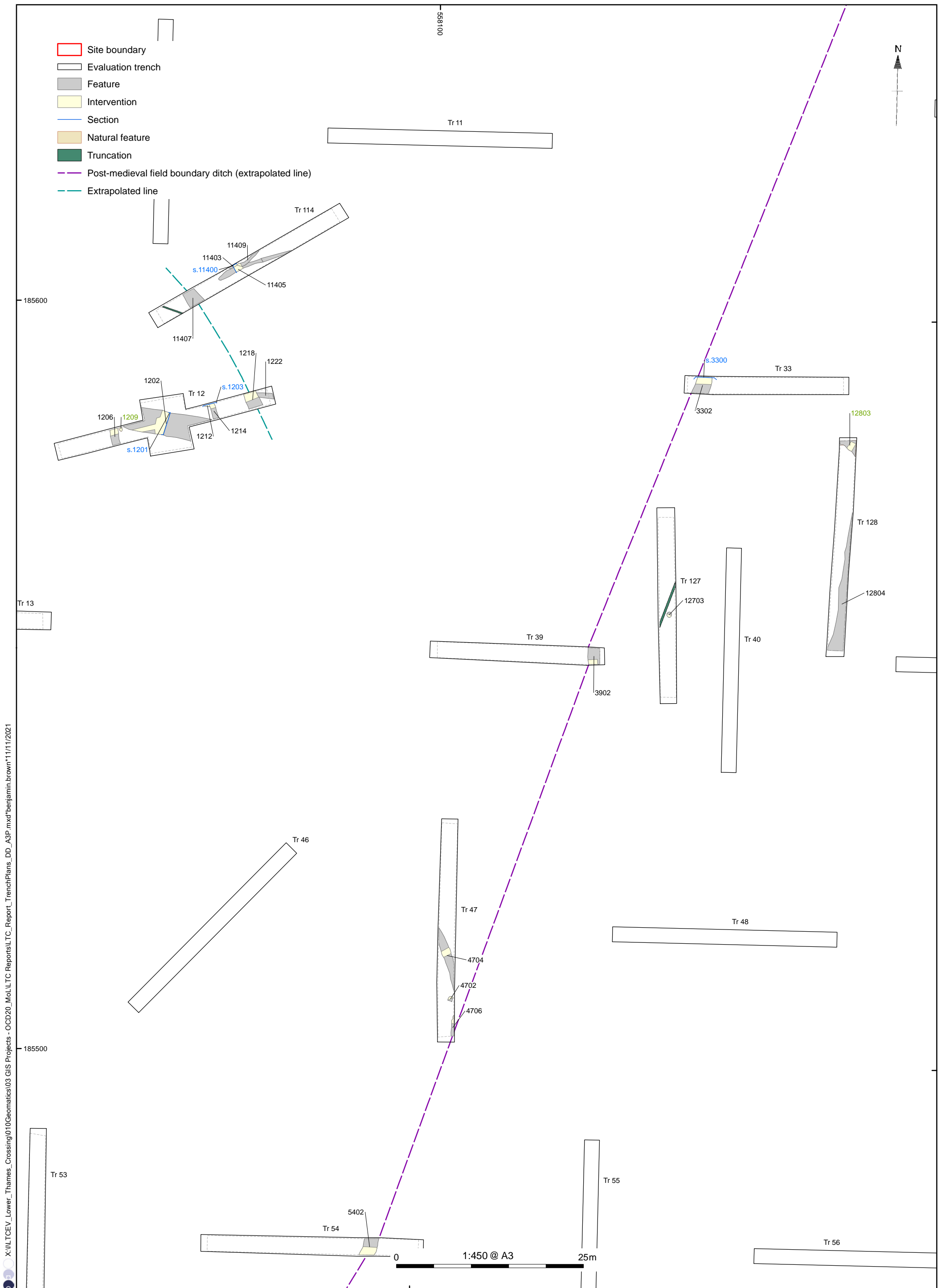

Figure 8: Plan of Trenches 12, 33, 39, 47, 54, 114, 127 and 128

X:\VILTCEV_Lower_Thames_Crossing\010\Geomatics\03 GIS Projects - OCD20_MoL\LC Reports\LC_Report_TrenchPlans_DD_A3P.mxd*benjamin.brown\11/11/2021

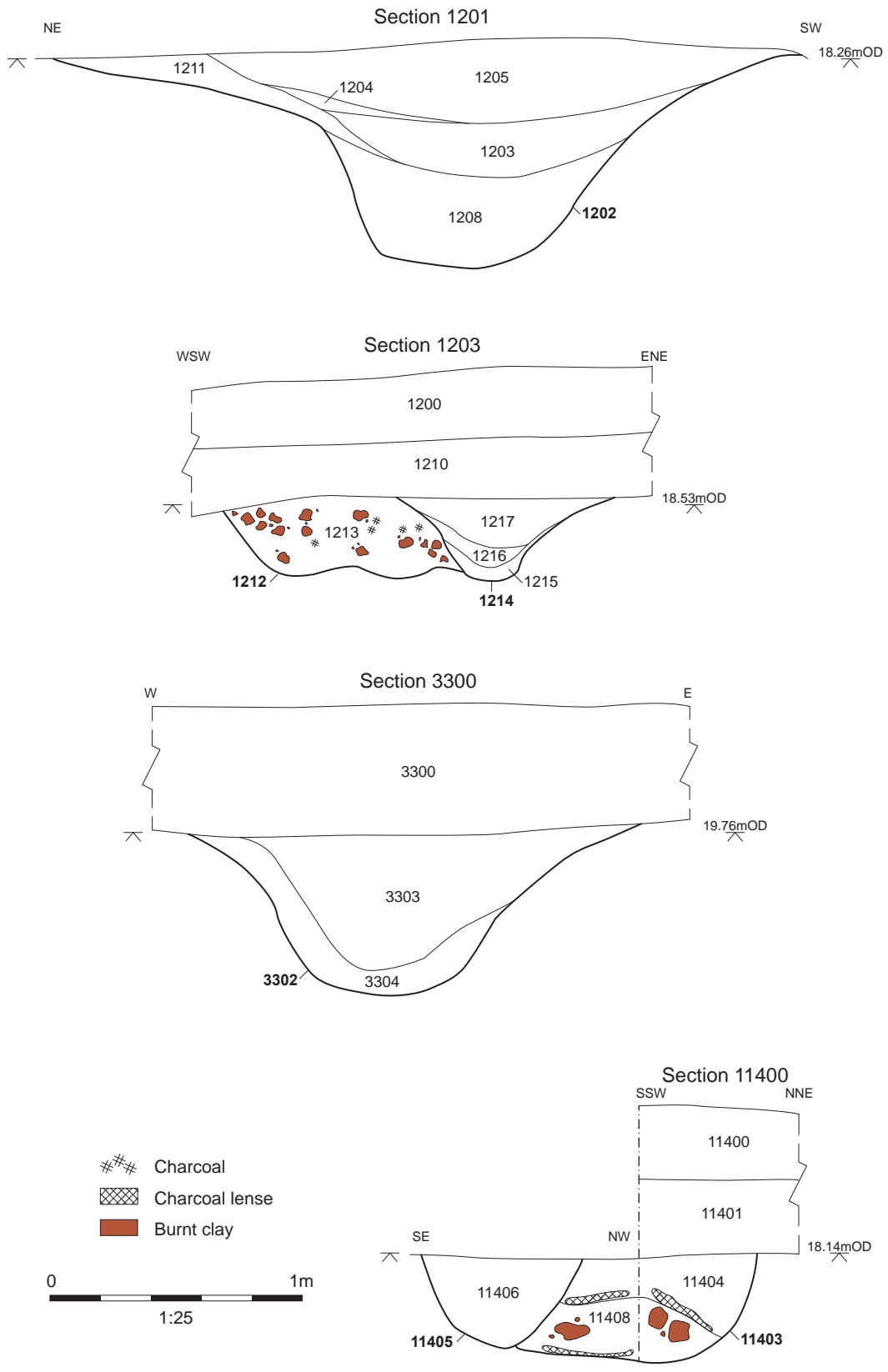

Figure 9: Sections (Trenches 12, 33 and 114)

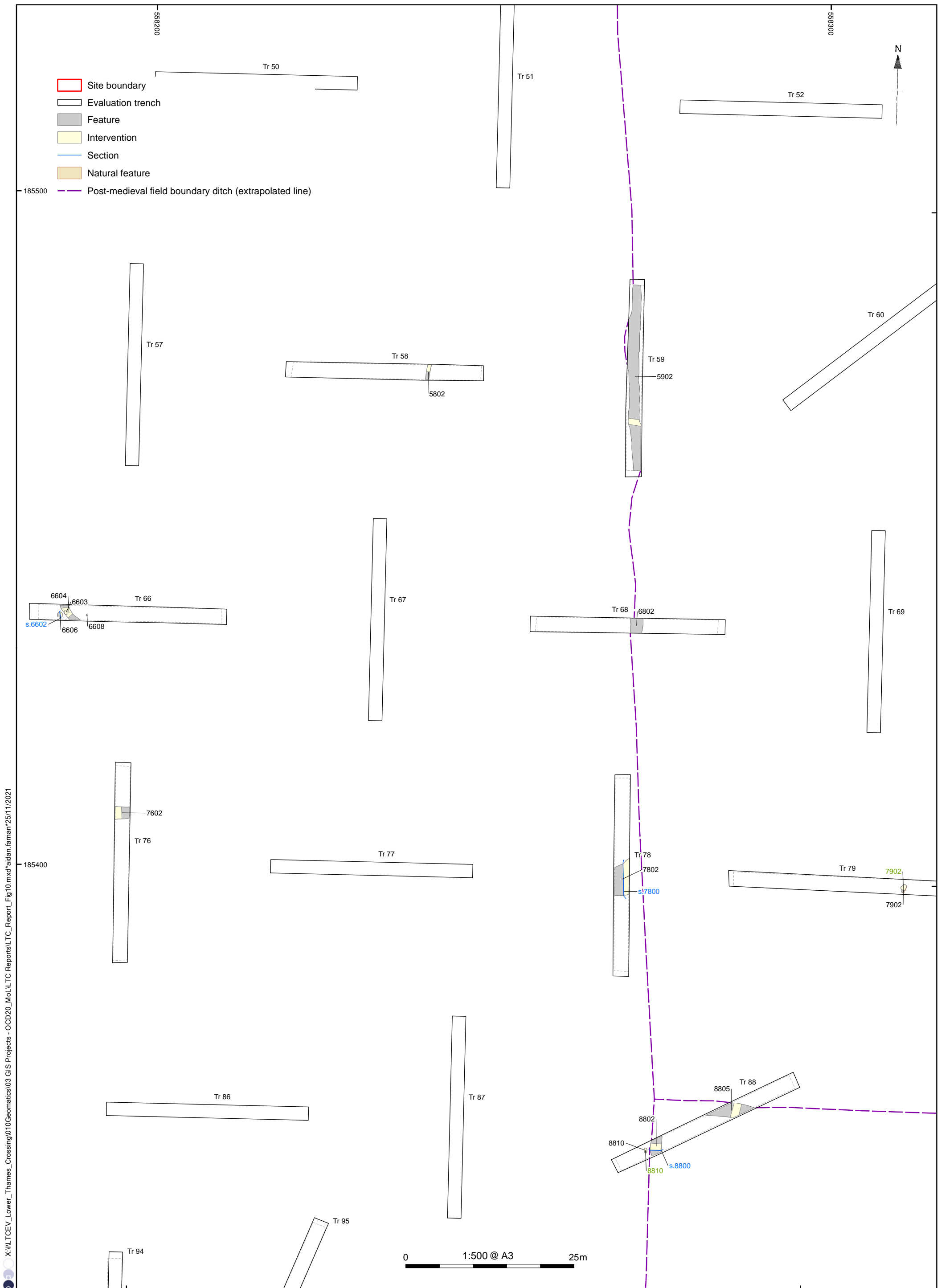
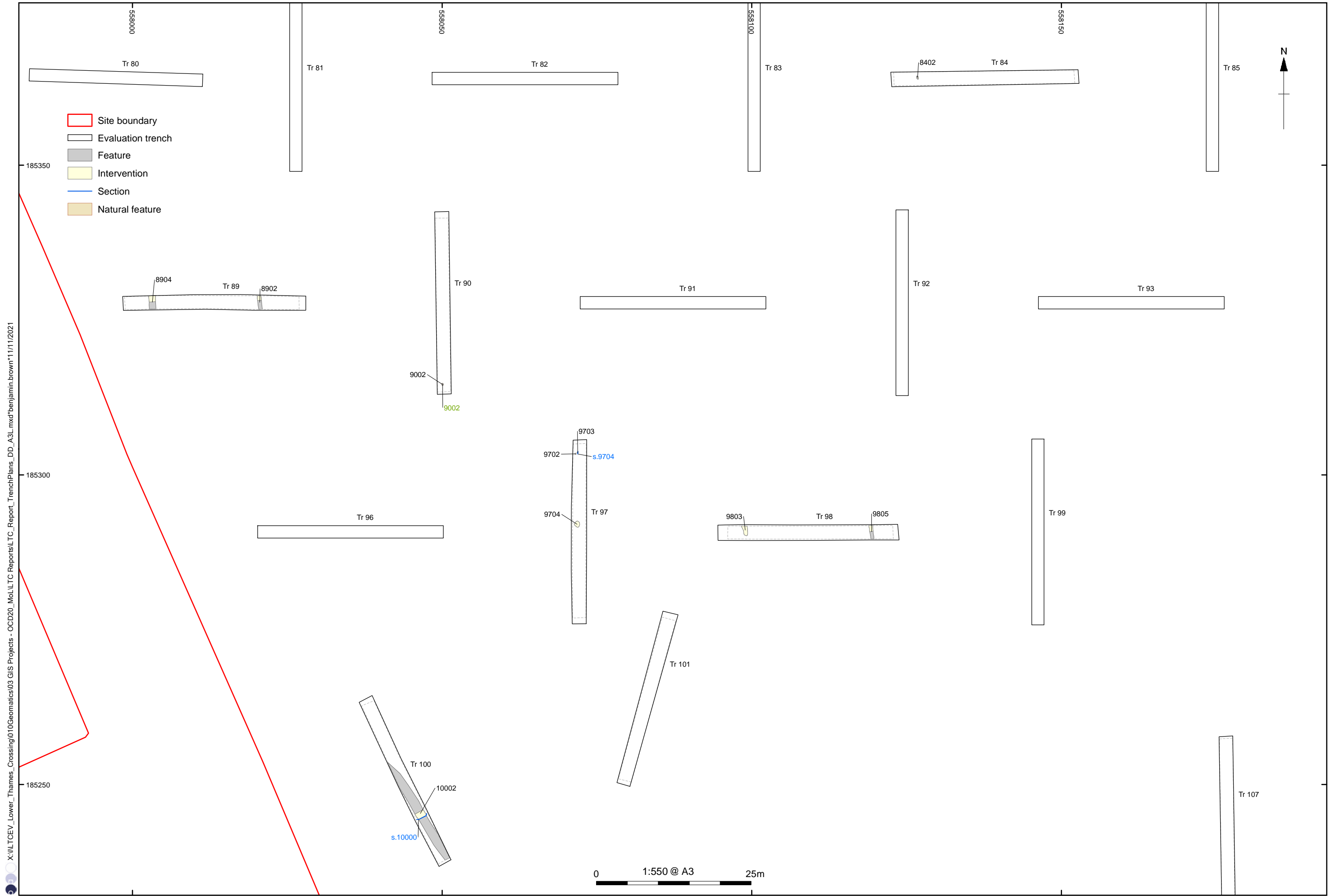

Figure 10: Plan of Trenches 58, 59, 66, 68, 76, 78 and 79



X:\ILTCEV_Lower_Thames_Crossing\010Geomatics\03 GIS Projects - OCD20_MoL\TC Reports\TC_Report_TrenchPlans_DD_A3.mxd*benjamin.brown*11/11/2021

Figure 11: Plan of Trenches 84, 89, 90, 97, 98 and 100

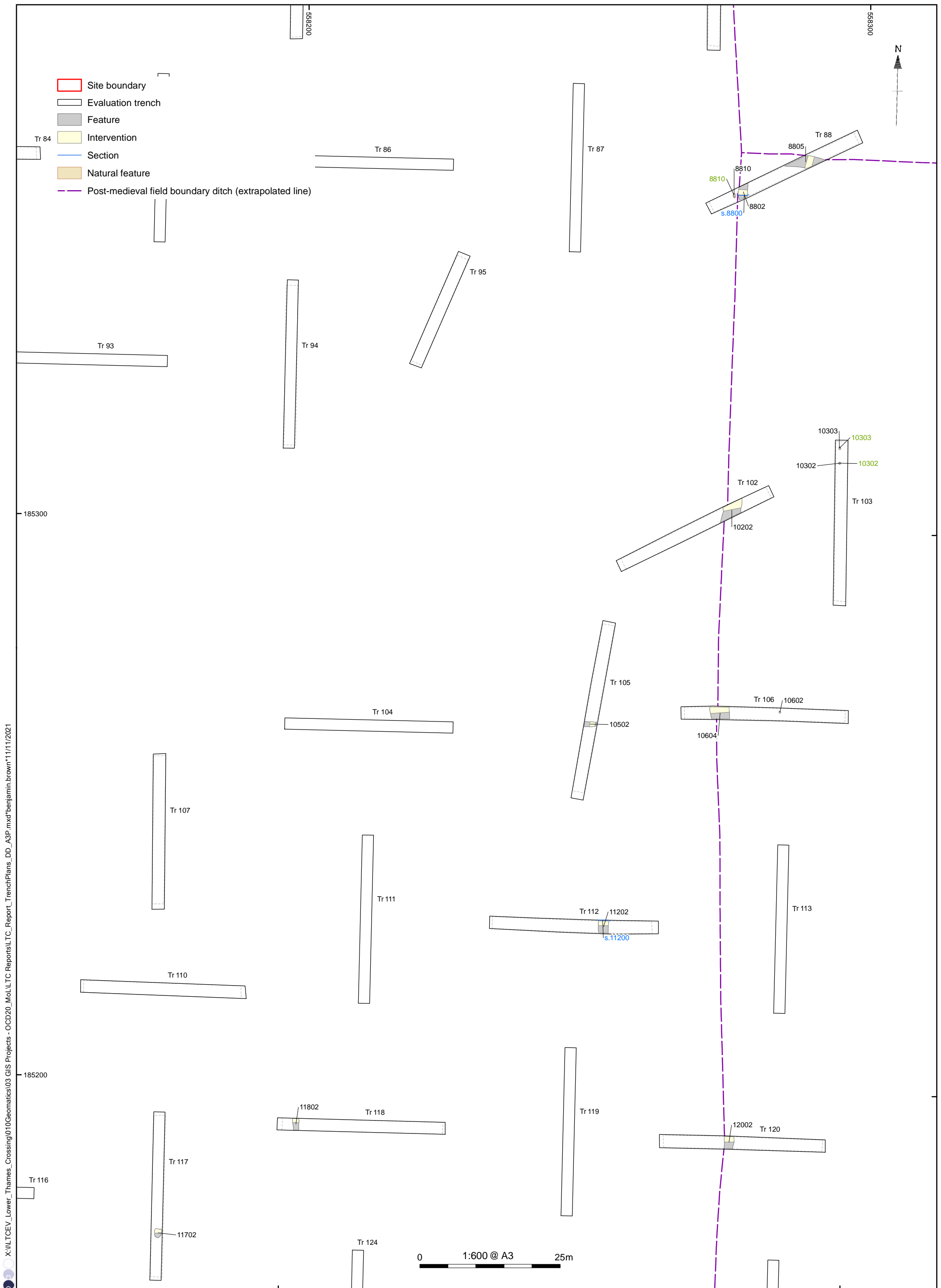

Figure 12: Plan of Trenches 88, 102, 103, 105, 106, 112, 117, 118 and 120

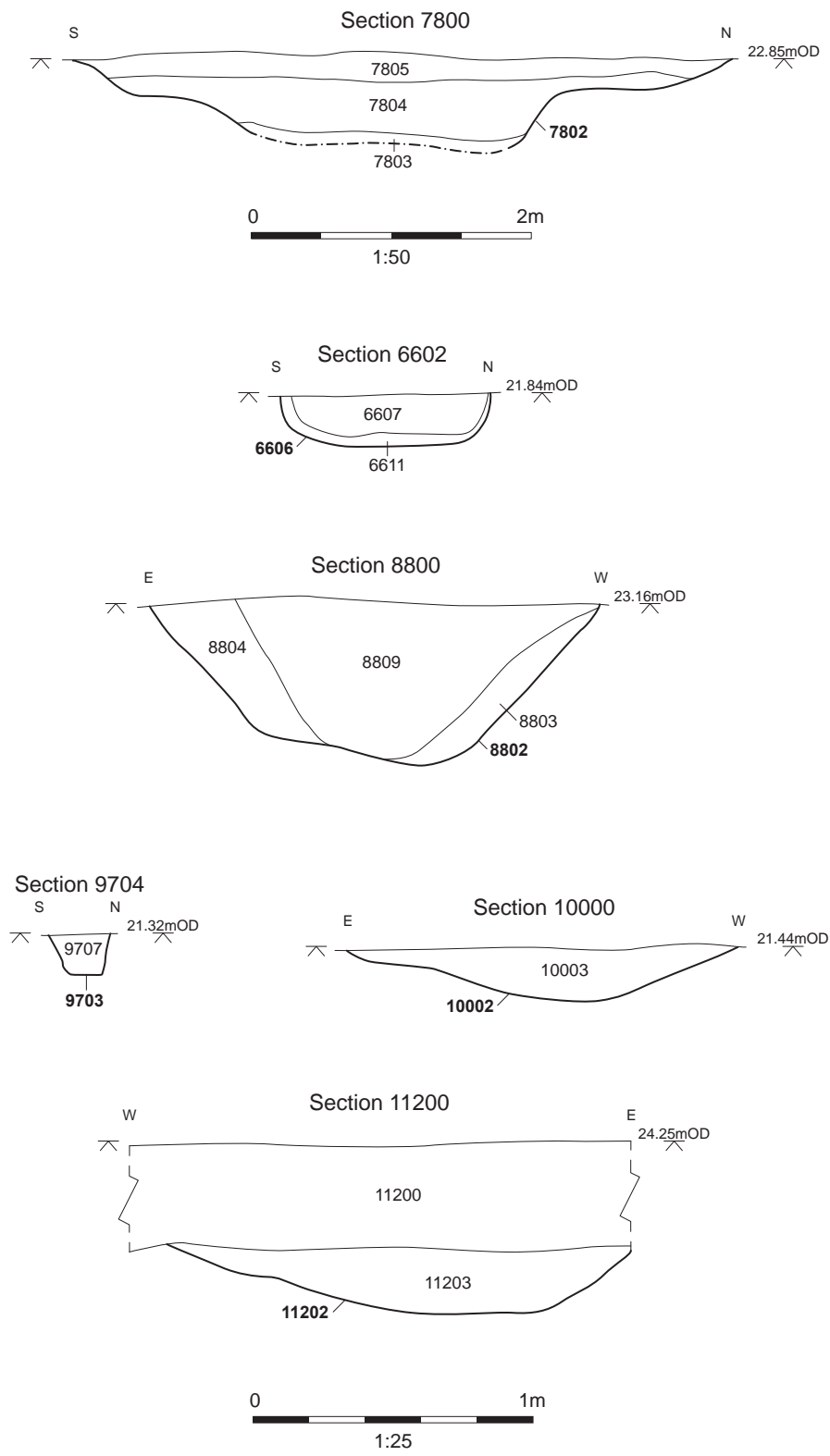

Figure 13: Sections (Trenches 66, 78, 88, 97, 100 and 112)

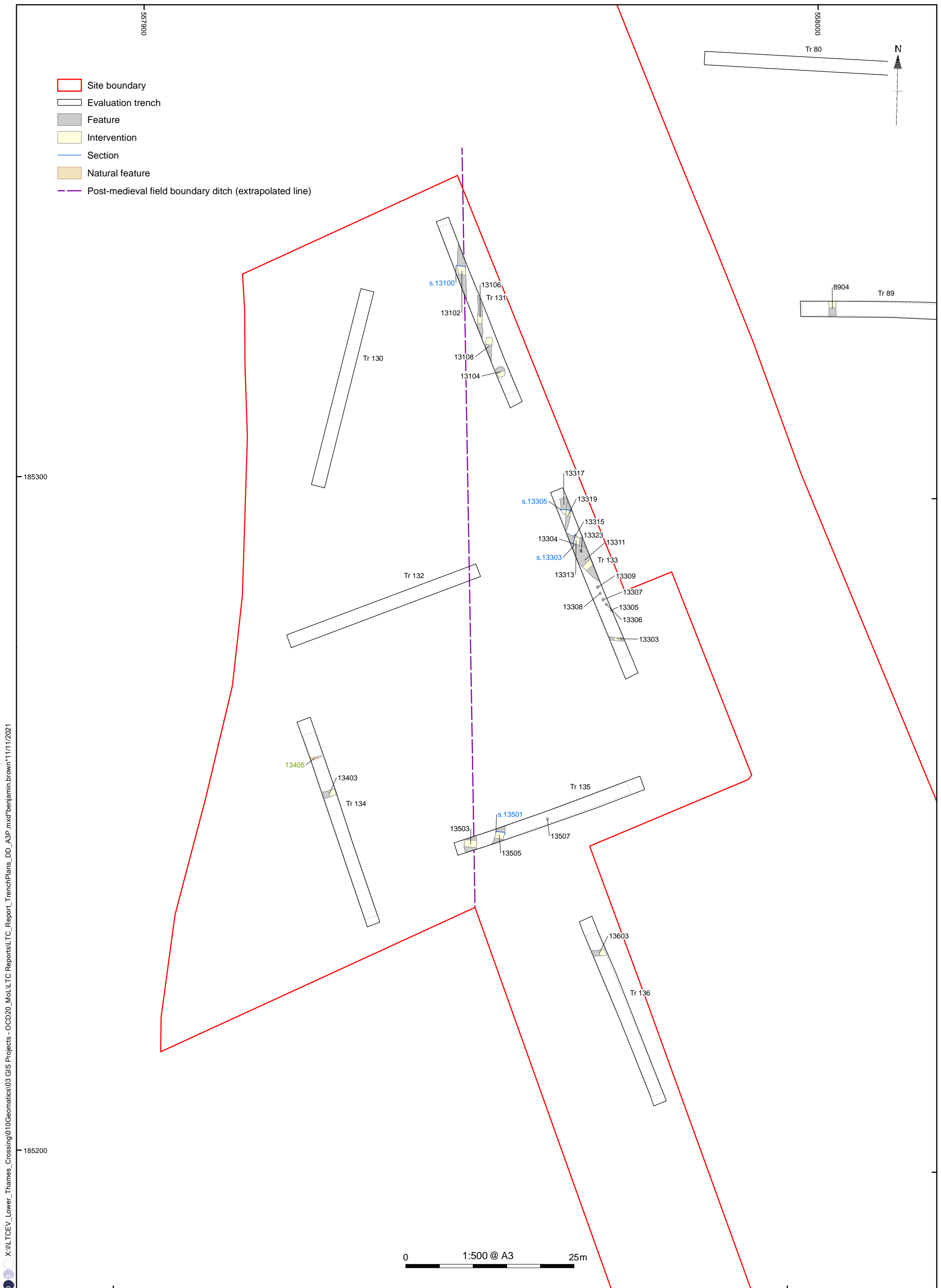

Figure 14: Plan of Trenches 131 and 133-6

X:\ILTCEV_Lower_Thames_Crossing\010Geomatics\03 GIS Projects - OCD20_MoL\TC Reports\TC_Report_TrenchPlans_DD_A3.mxd*benjamin.brown*11/11/2021

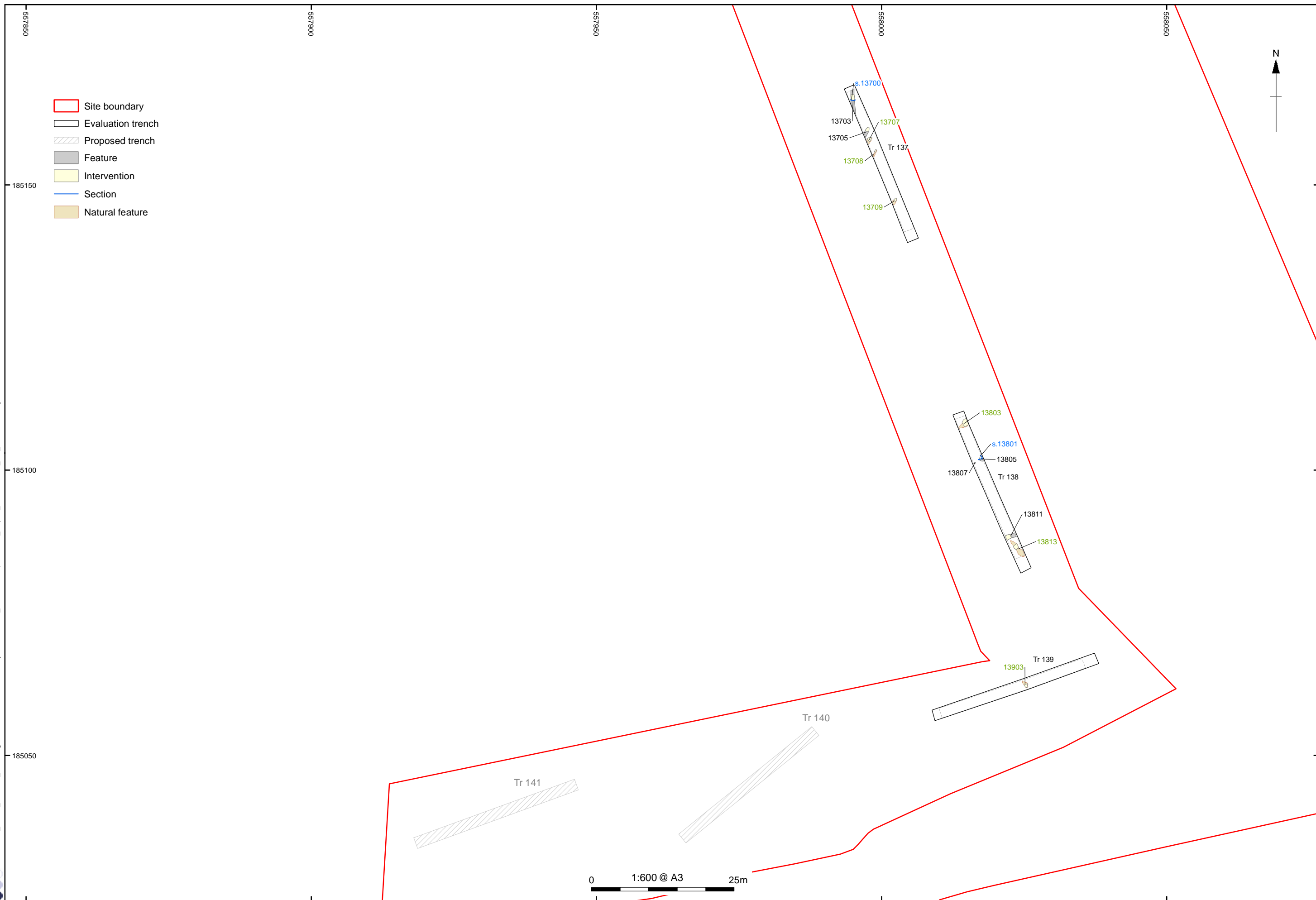

Figure 15: Plan of Trenches 137 and 138

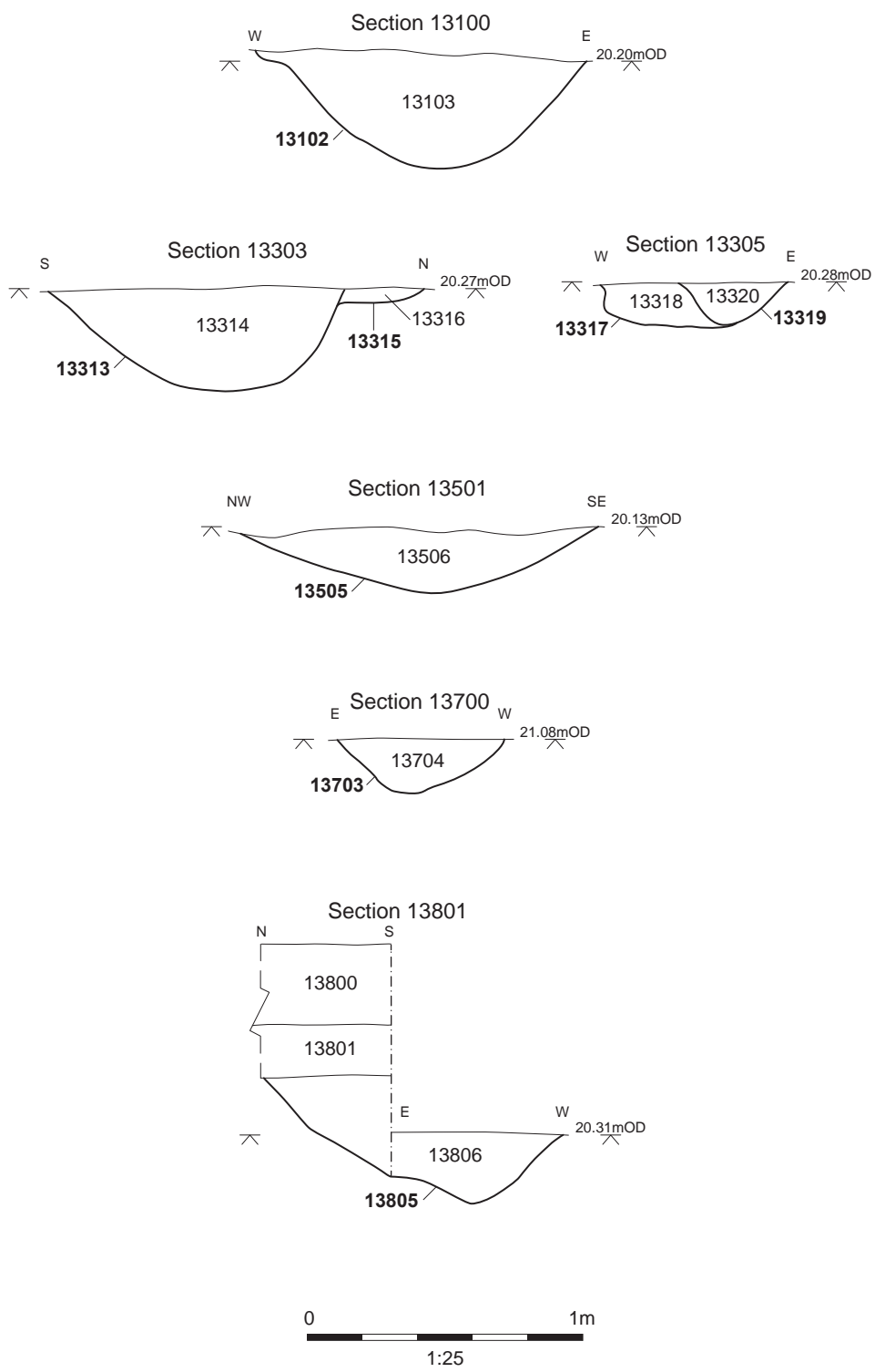
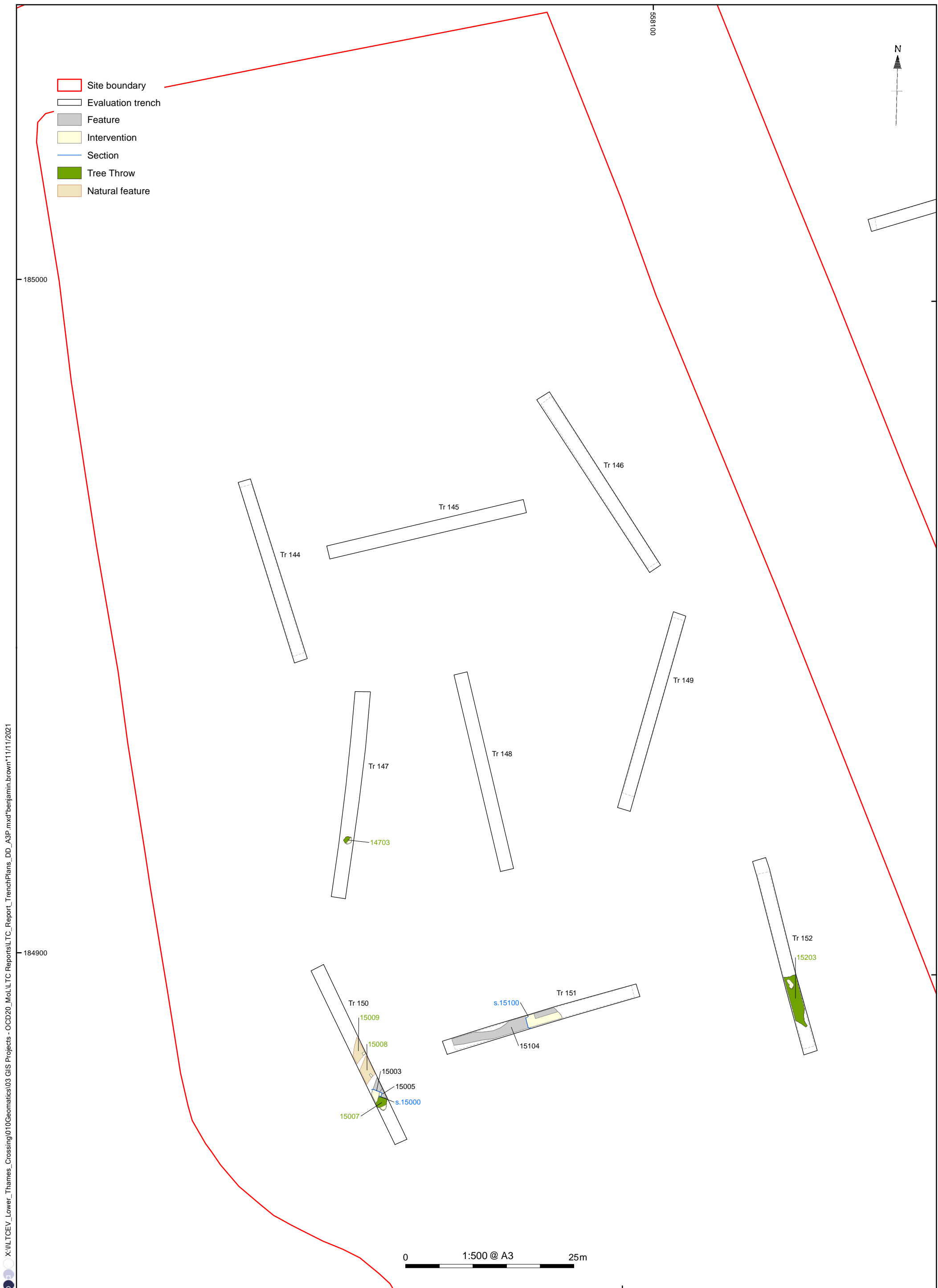

Figure 16: Sections (Trenches 131, 133, 135, 137 and 138)



X:\ILTCEV_Lower_Thames_Crossing\010\Geomatics\03 GIS Projects - OCD20_MoL\LC Reports\LC_Report_TrenchPlans_DD_A3P.mxd*benjamin.brown*11/11/2021

Figure 17: Plan of Trenches 150-152

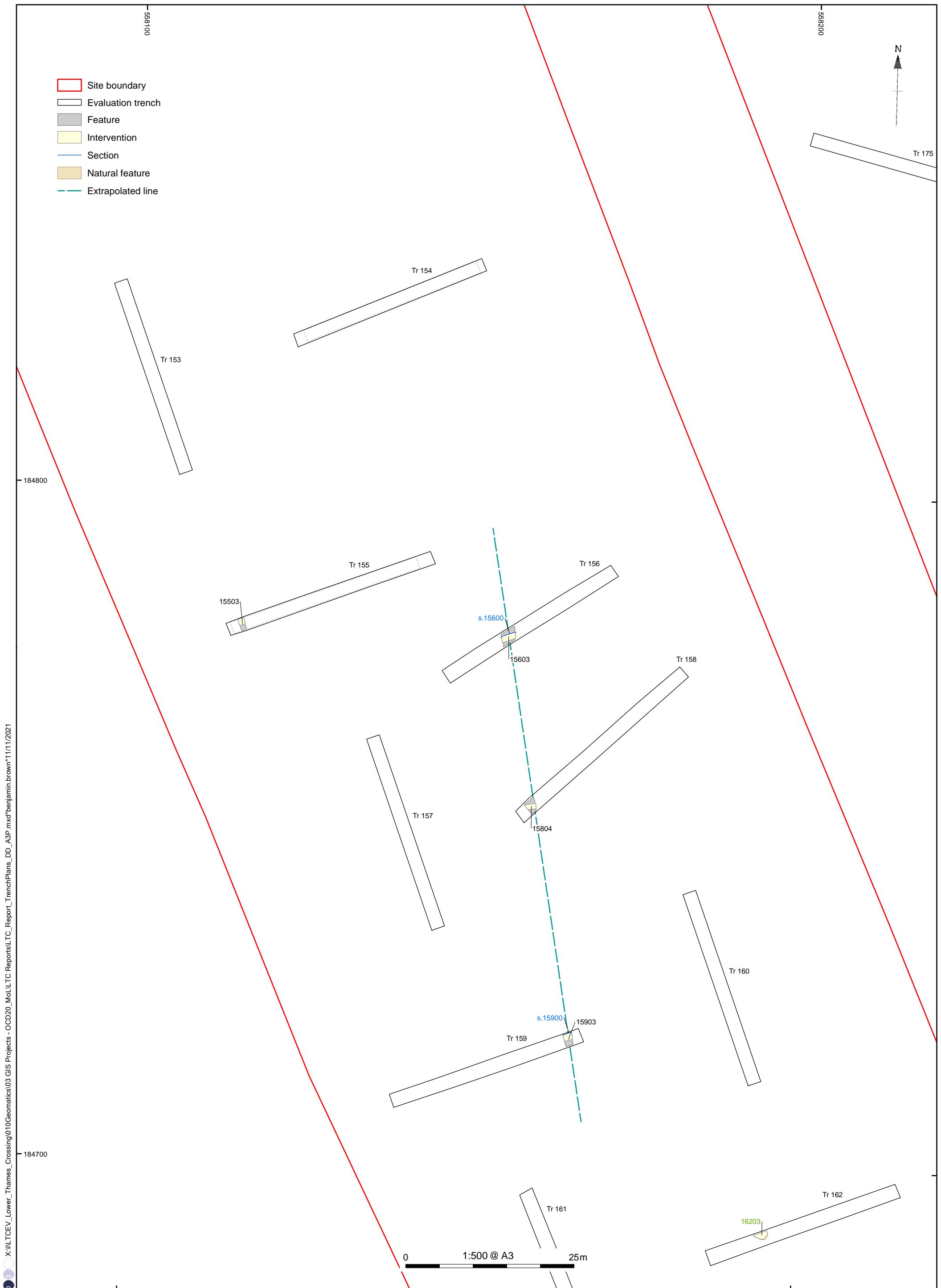

Figure 18: Plan of Trenches 155, 156 and 158-9

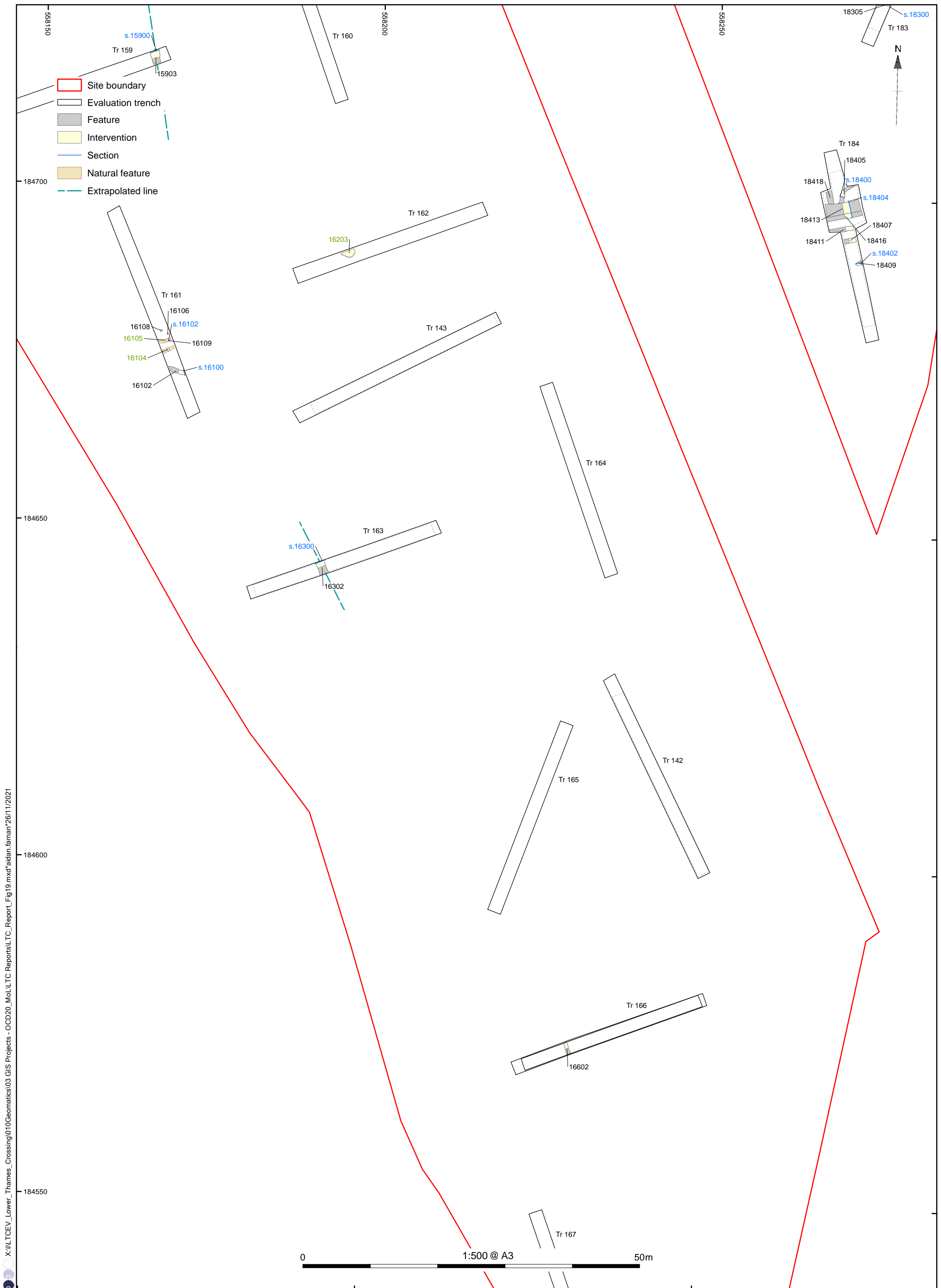

Figure 19: Plan of Trenches 161, 163 and 166

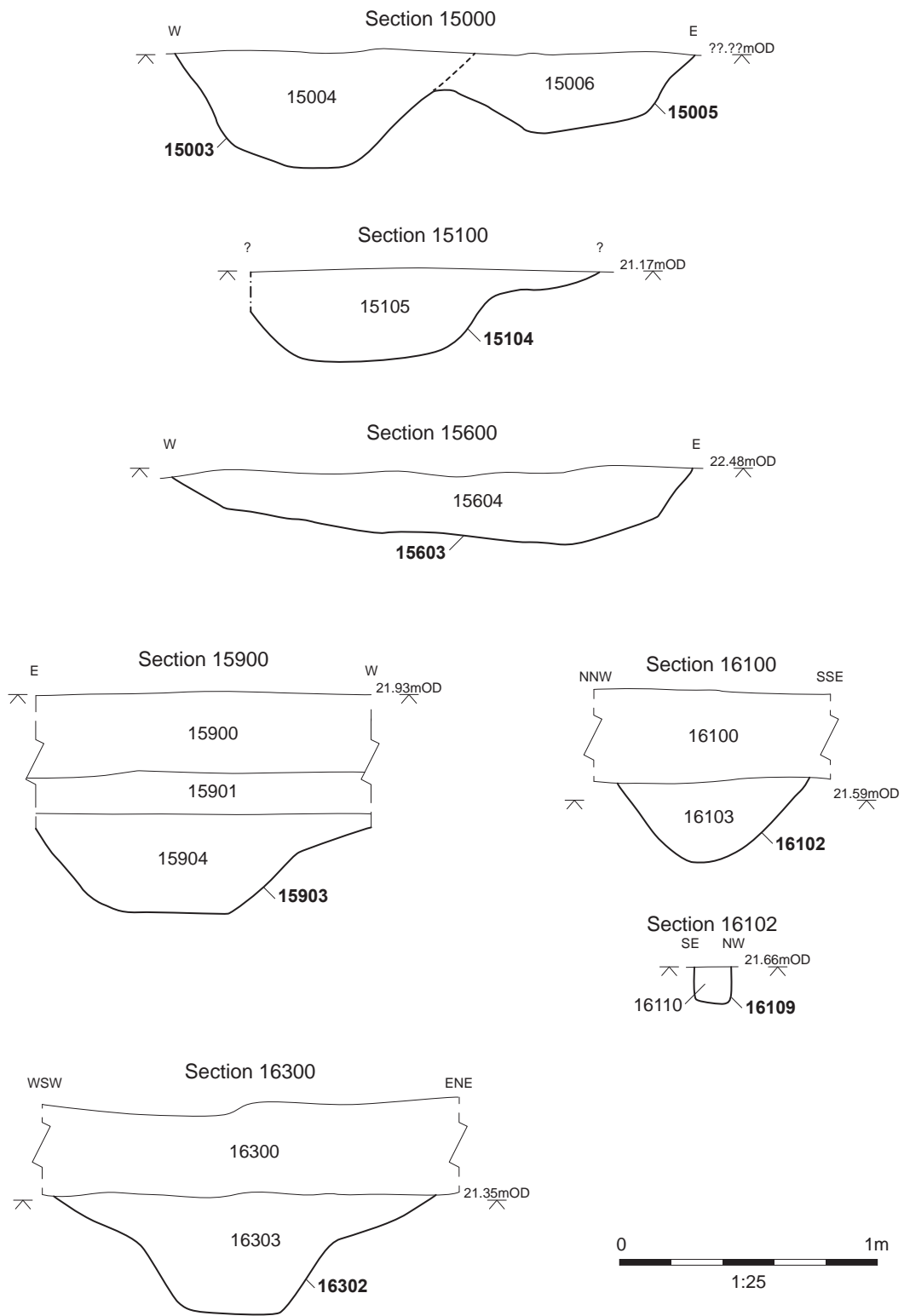

Figure 20: Sections (Trenches 150, 151, 156, 159, 161 and 163)

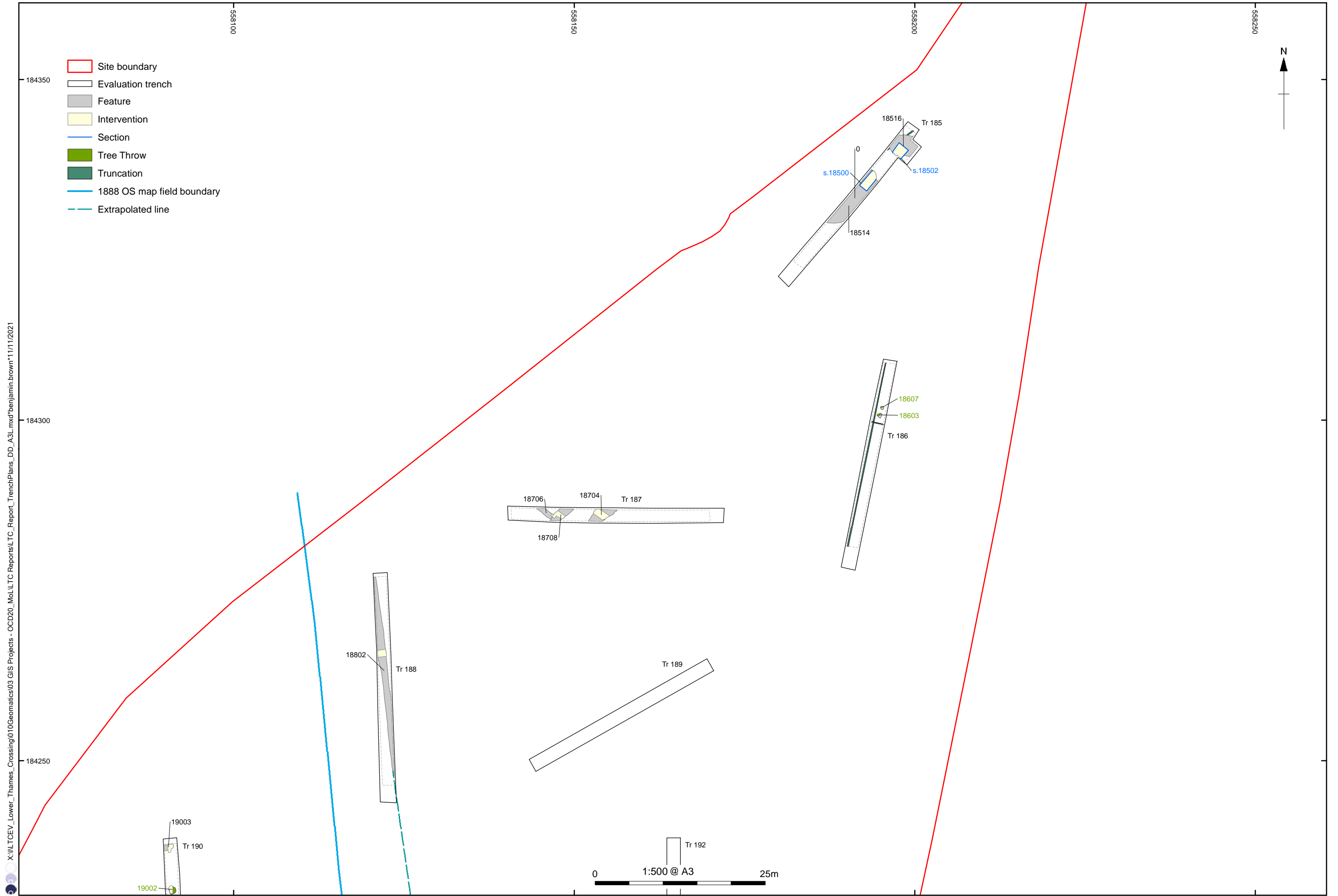

Figure 21: Plan of Trenches 185, 186, 187 and 188

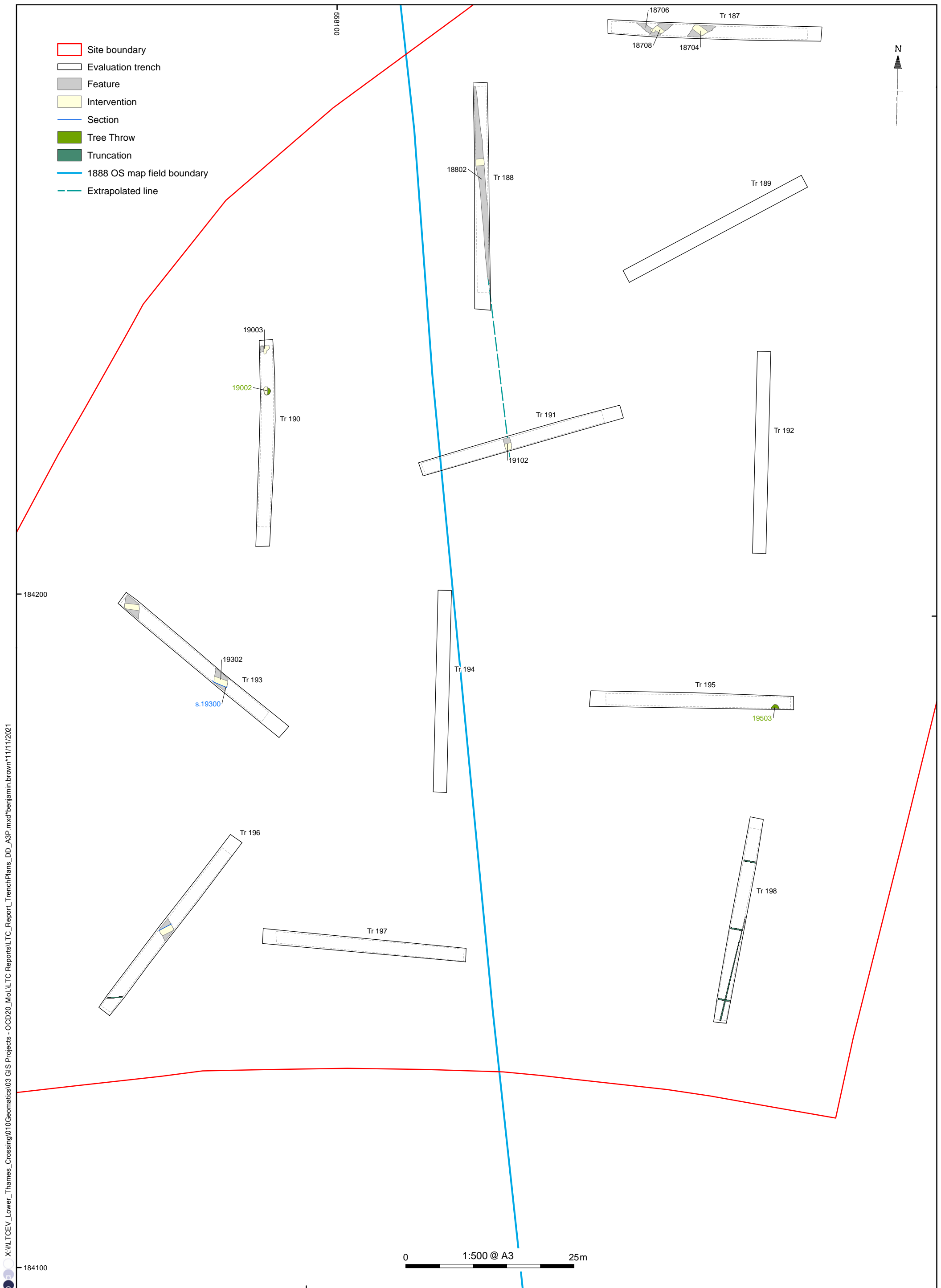

Figure 22: Plan of Trenches 190, 191, 193, and 196

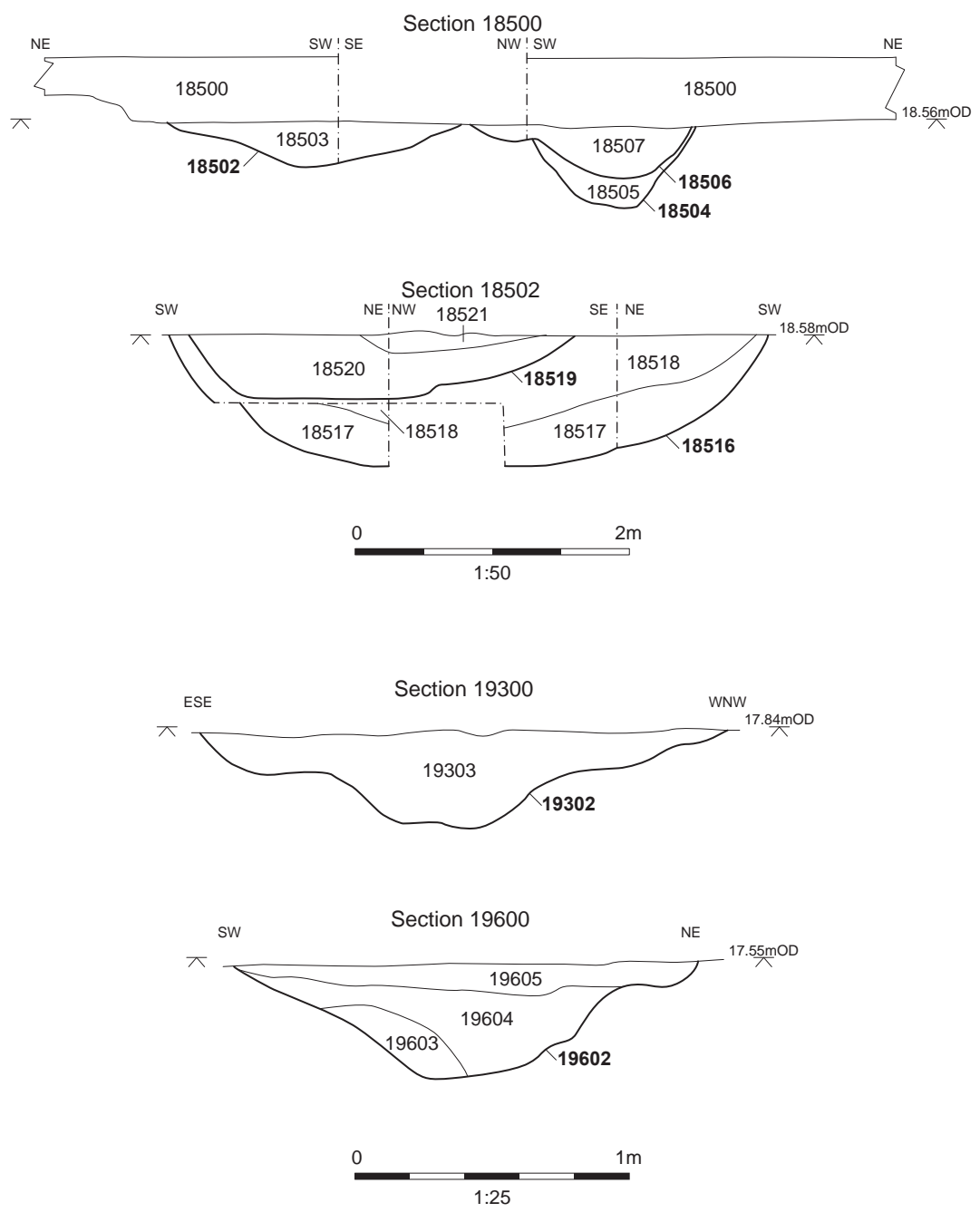

Figure 23: Sections (Trenches 185, 193 and 196)

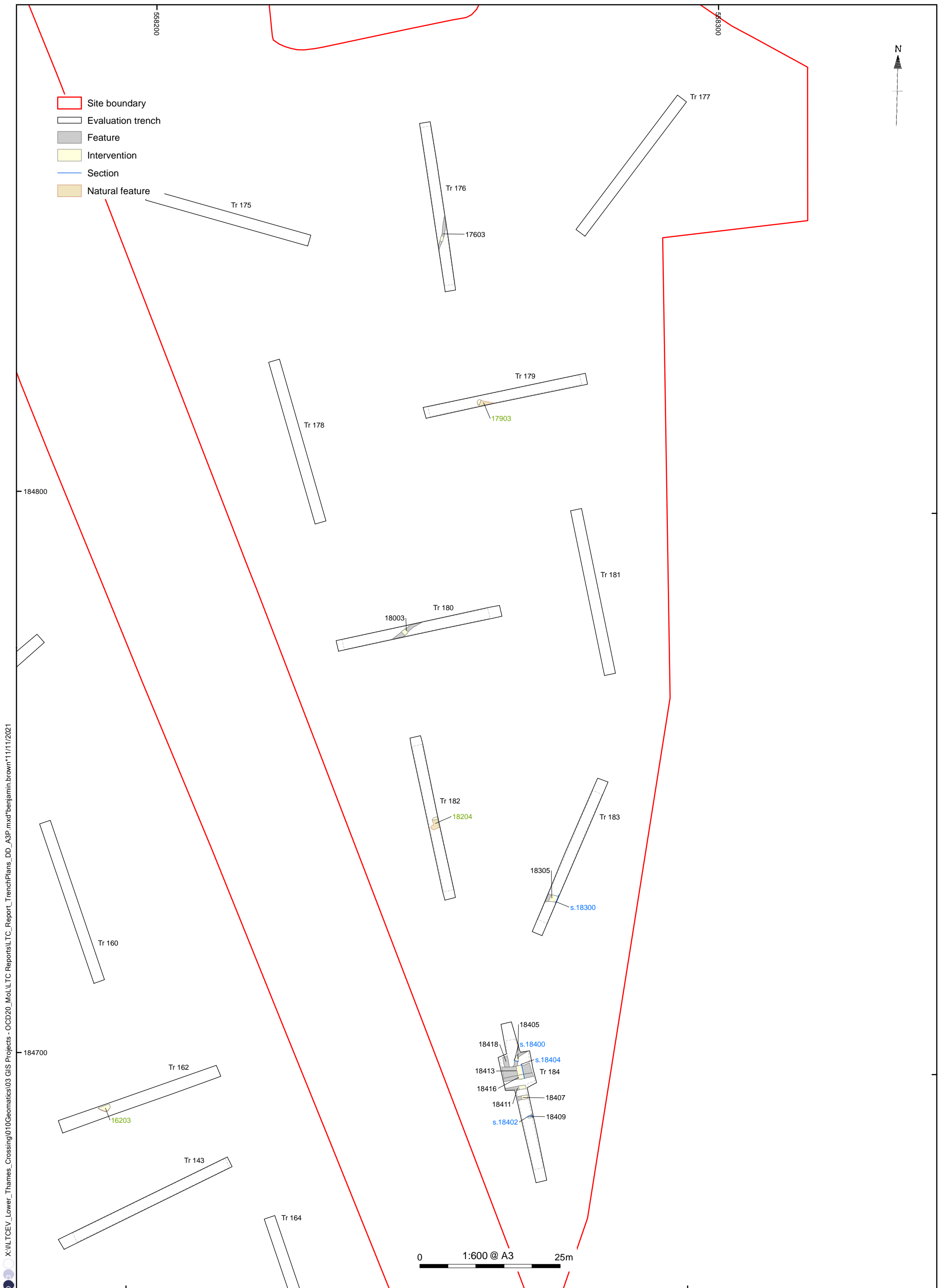

Figure 24: Plan of Trenches 176, 180, 183 and 184

X:\ILTCEV_Lower_Thames_Crossing\010\Geomatics\03 GIS Projects - OCD20_MoL\LC Reports\LC_Report_TrenchPlans_DD_A3P.mxd*benjamin.brown*11/11/2021

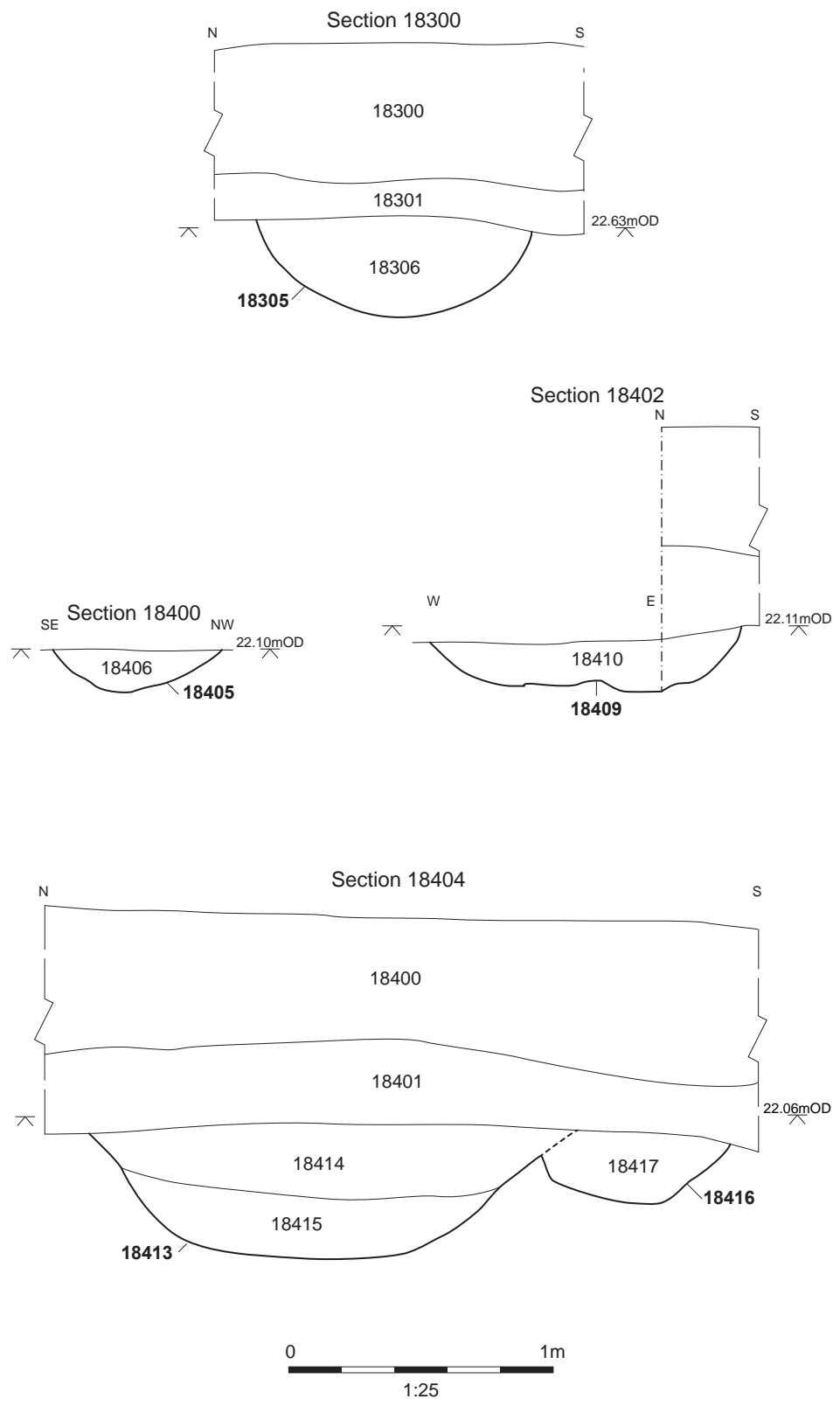

Figure 25: Sections (Trenches 183 and 184)

X:\ILTCEV_Lower_Thames_Crossing\010Geomatics\03 GIS Projects - OCD20_MoL\TC Reports\TC_Report_Fig26.mxd*aidan.farnan*25/11/2021

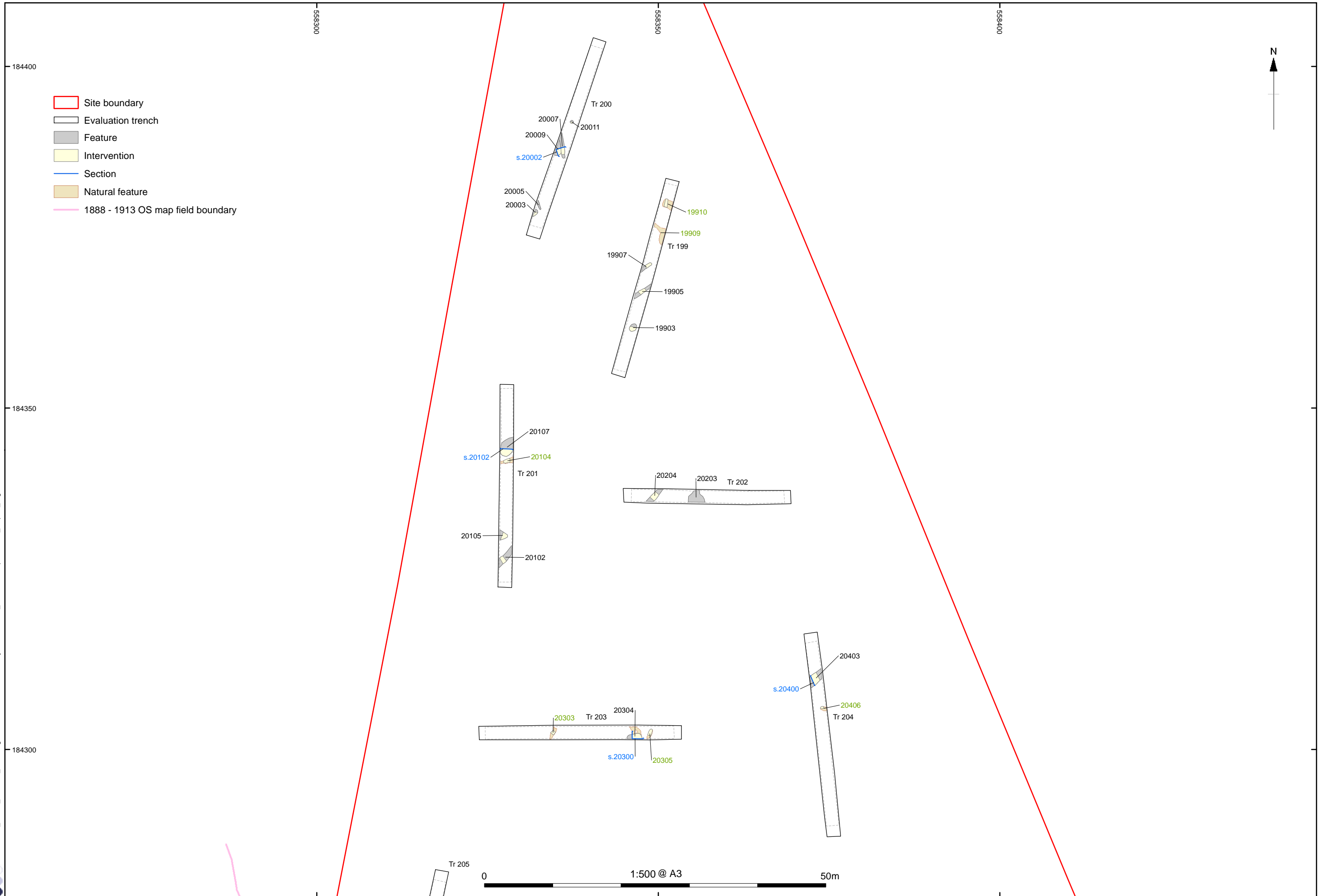

Figure 26: Plan of Trenches 199-204

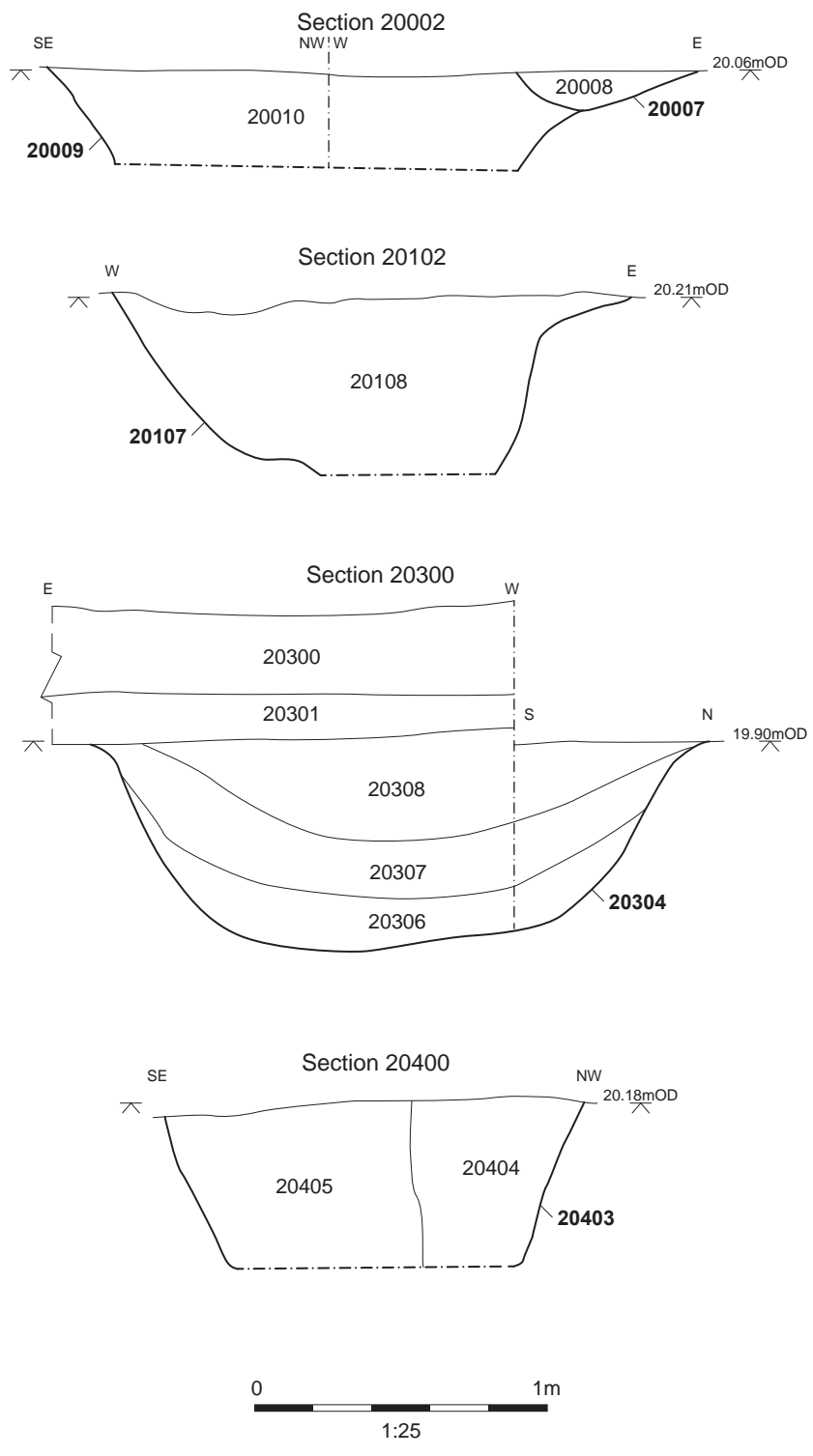

Figure 27: Sections (Trenches 200, 201, 203 and 204)

X:\ILTCEV_Lower_Thames_Crossing\010\Geomatics\03 GIS Projects - OCD20_MoL\TC Reports\TC_Report_Fig28.mxd*aidan.farnan*25/11/2021

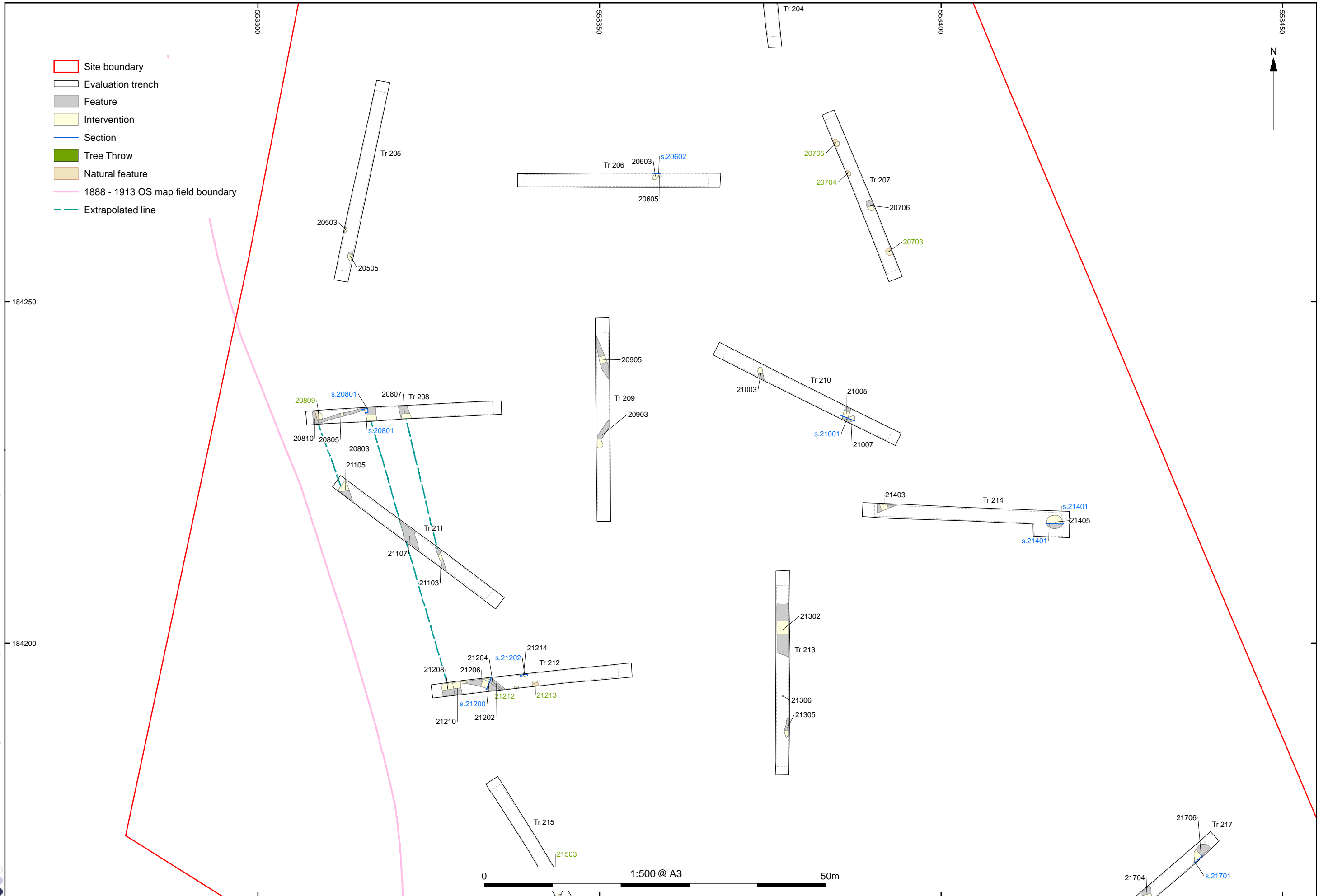

Figure 28: Plan of Trenches 205-214

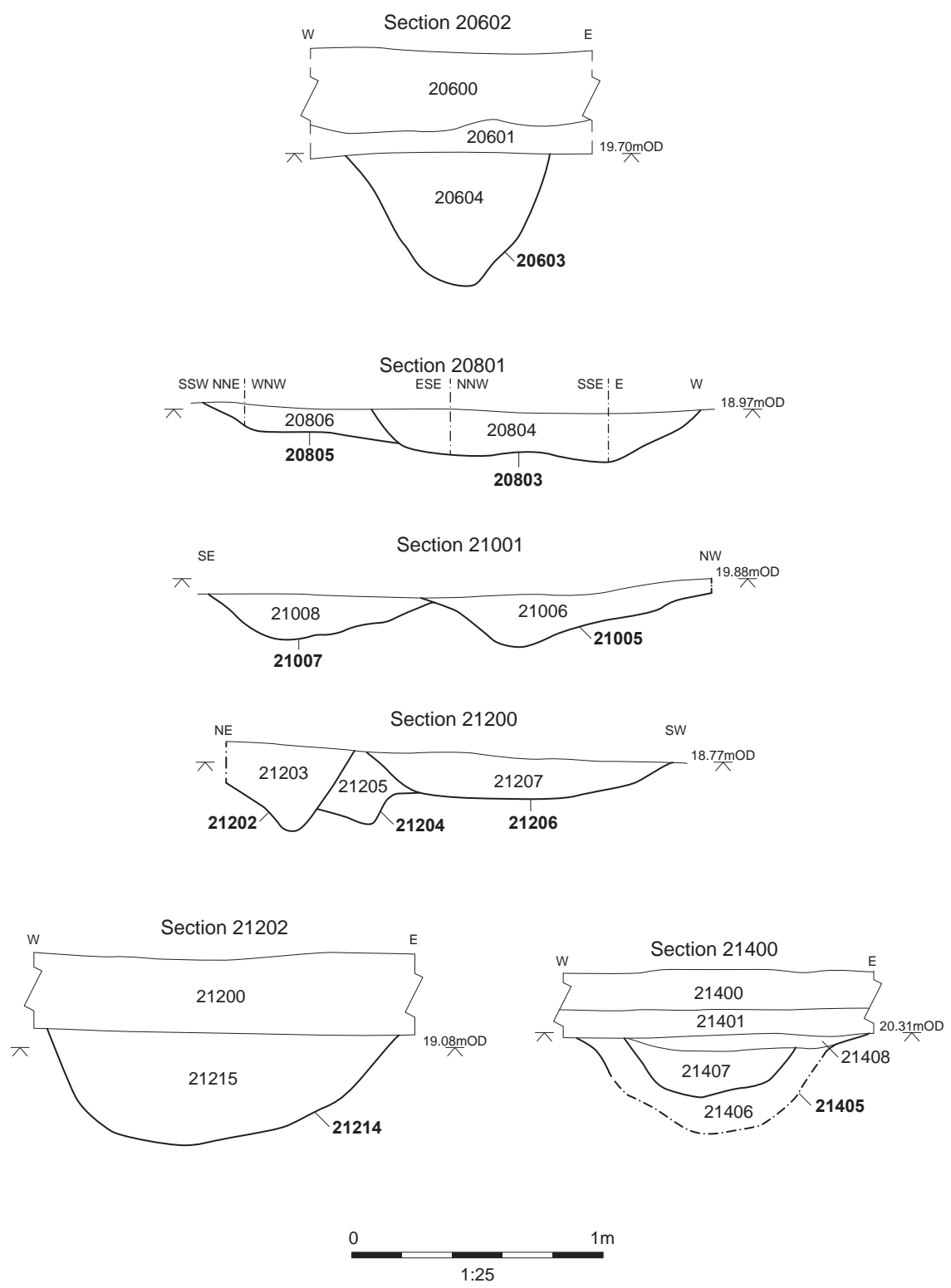

Figure 29: Sections (Trenches 206, 208, 210, 212 and 214)

X:\ILTCEV_Lower_Thames_Crossing\010\Geomatics\03 GIS Projects - OCD20_Mol\LTTC_Reports\LTTC_Report_Fig30.mxd*aidan.farnan*25/11/2021

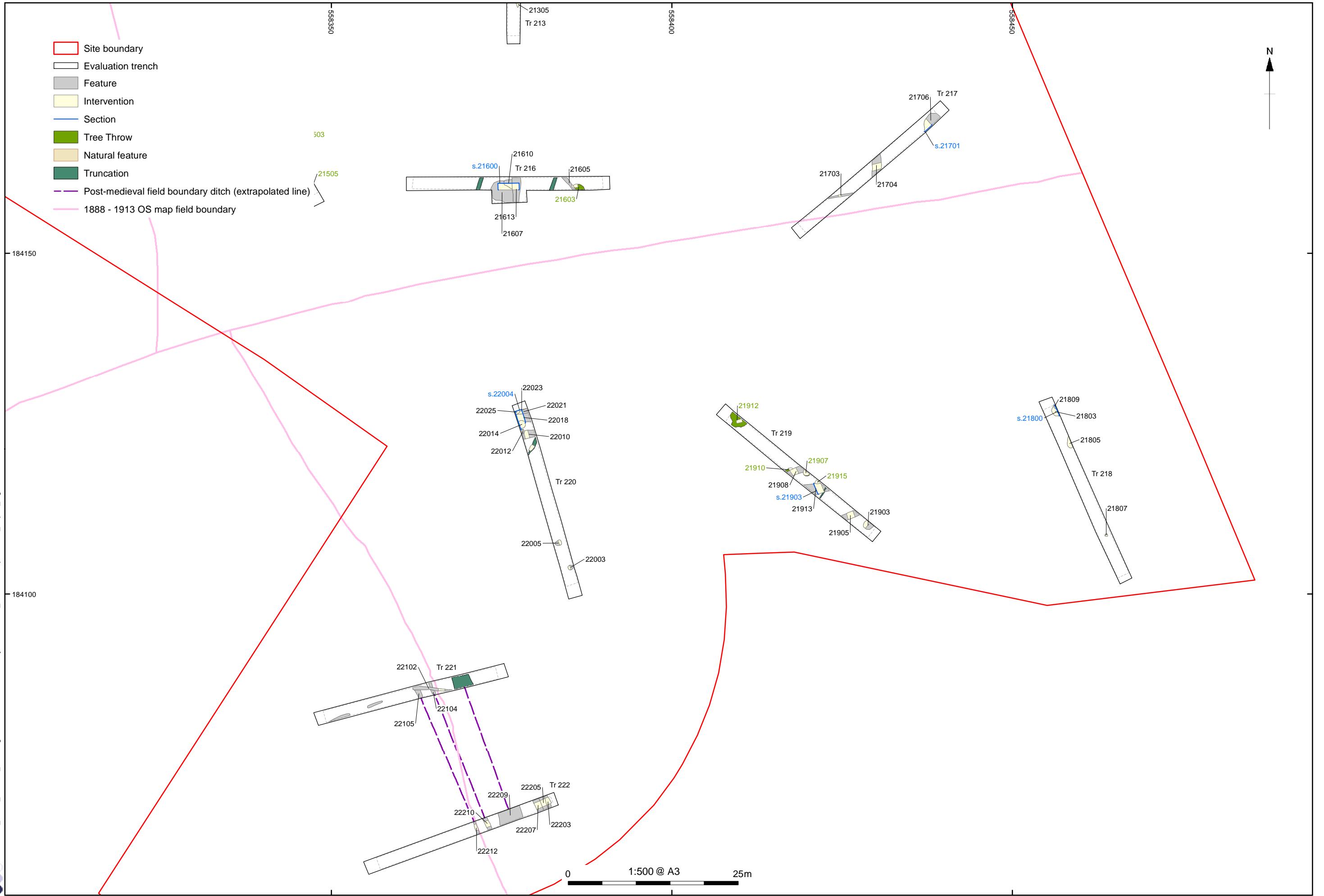

Figure 30: Plan of Trenches 216-222

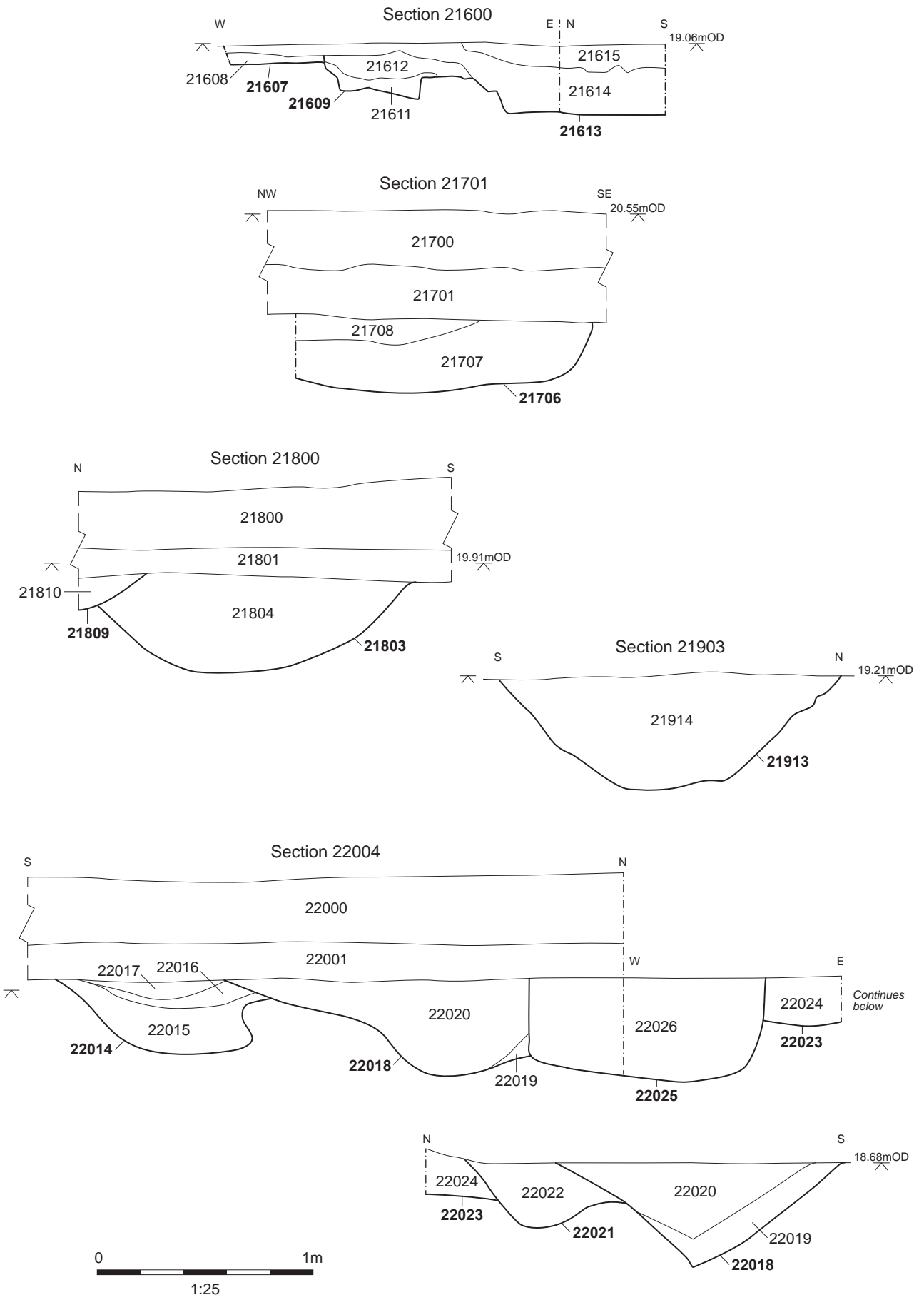
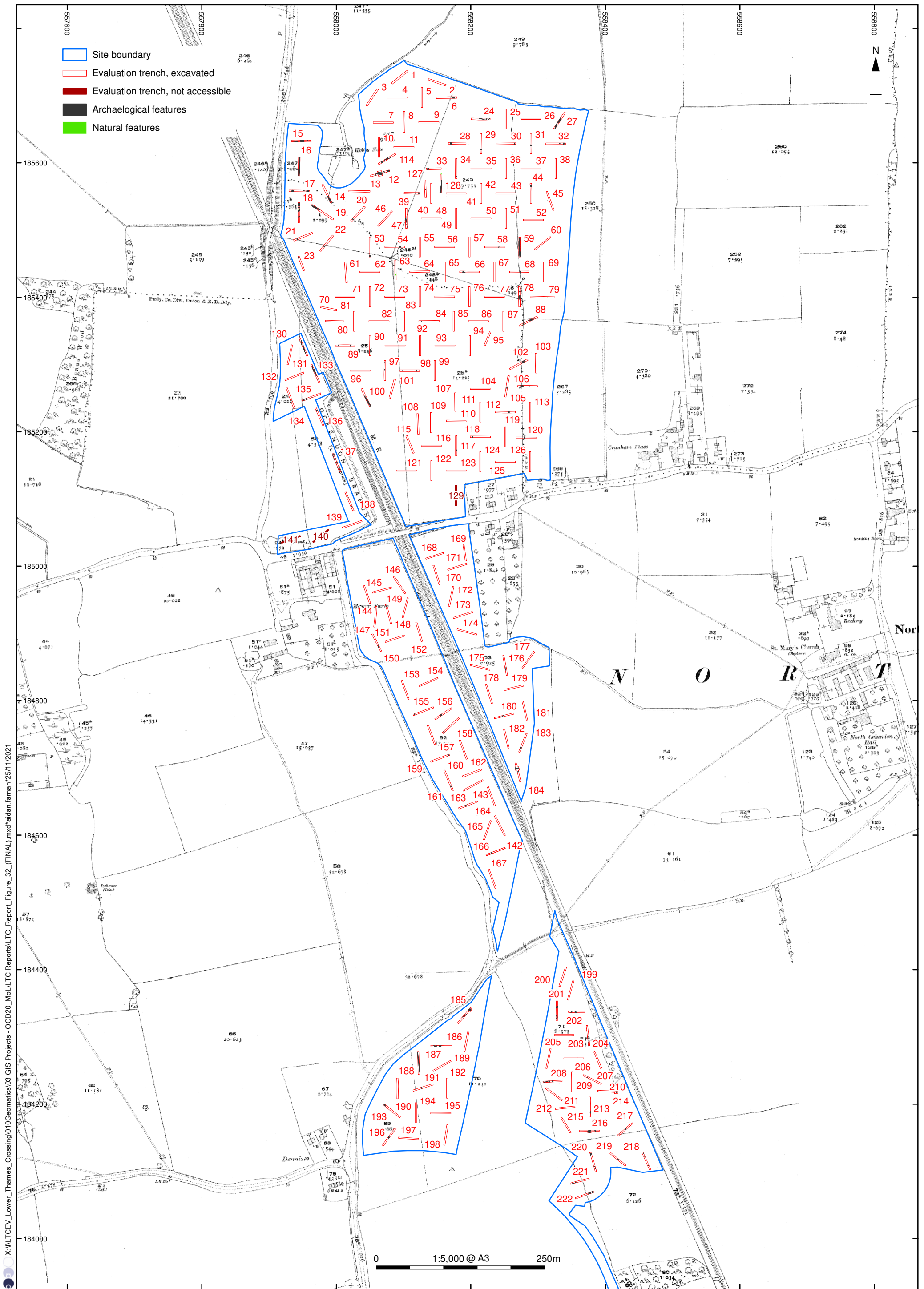

Figure 31: Sections (Trenches 216, 217, 218, 219 and 220)



X:\ILITCEV_Lower_Thames_Crossing\010\Geomatics\03_GIS Projects - OCD20_MoL\ITC Reports\ITC_Report_Figure_32_(FINAL).mxd*aidan.faman*25/11/2021

Contains Ordnance Survey data © Crown copyright and database right 2020, provided by client

Figure 32 : Ordnance Survey (1897)

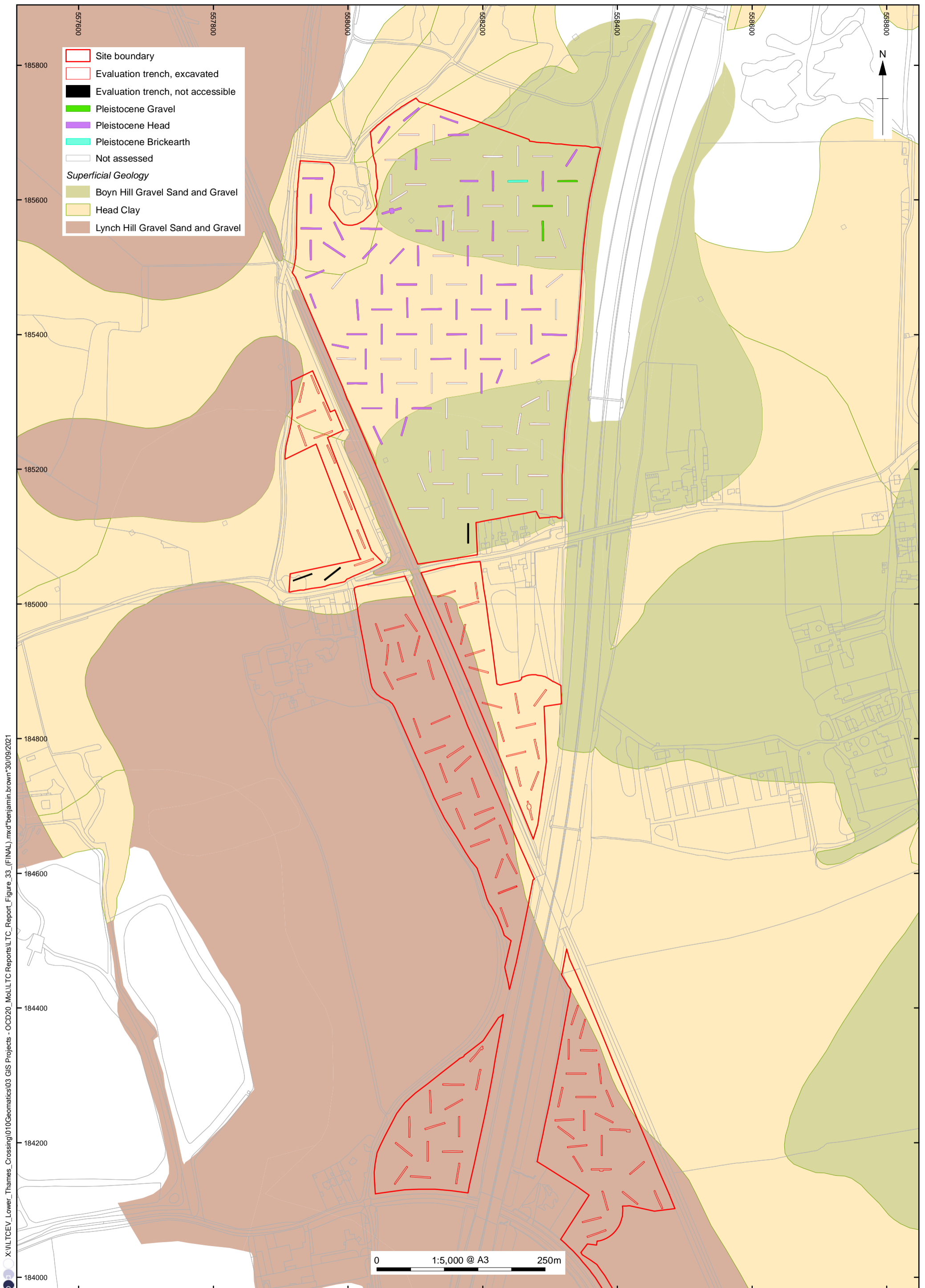

X:\ILTCEV_Lower_Thames_Crossing\010\Geomatics\03 GIS Projects - OCD20_Mo\ILTCEV Reports\LT_Report_Figure_33_(FINAL).mxd\benjamin.brown\30/09/2021

Contains Ordnance Survey data © Crown copyright and database right 2020, provided by client
 Contains British Geological Survey materials © UKRI 2020

Figure 33 : Results of geoaerchaeological investigation



Plate 1: Trench 13, looking north-west



Plate 2: Ditch 1602, looking south



Plate 3: Pit 2302, looking west



Plate 4: Pit 2702/2718, looking north



Plate 5: Pit 3204, looking north



Plate 6: Pit 11403 and ditch 11405, looking west



Plate 7: Pit 4702, looking south-east



Plate 8: Pit 6603 containing a middle Bronze Age vessel (6610=SF 2)



Plate 9: Working shot of inverted urn excavation (SF 1) from pit 9704



Plate 10: Postholes 9702 and 9703, looking south



Plate 11: Ditch 10604, looking north



Plate 12: Ditch 11802, looking north



Plate 13: Ditch 13311, looking south-west



Plate 14: Ditch 18411, looking south-east



Plate 15: Tree-throw 20304, looking south-west



Plate 16: Ditch 21105, looking south



Plate 17: Ditch 21913, looking west



Plate 18: Ditches 22018, 22021 and 22023, looking east



Plate 19: Ditches 22203, 22205 and 22207, looking south

COVER SHEET

Title:	Archaeological Evaluation Report for Trial Trenching of Land Parcels 41, 42, 44 and 60 Land South of Ockendon, in Thurrock, Essex, and the London Borough of Havering
Project Name:	Lower Thames Crossing Enabling Works
Ref No:	HE540039-BAL-GEN-GEN-REP-HER-00025
Revision No:	P02
Review Date:	10/11/2021
Status:	S2
No. of Pages	301

Rev	Date of Issue	Revision Status	Originator	Checker	Approver
P02	27/01/2021	S2	Bikash Rana	Jack Fletcher	Sam Ashton
P02	10/11/2021	S2	Conal Mundy	Jack Fletcher	George Pargeter



Lower Thames Crossing

Archaeological Evaluation Report for Trial Trenching of Land Parcels 41, 42, 44 and 60 Land South of Ockendon, in Thurrock, Essex, and the London Borough of Havering

Document Number: HE540039-BAL-GEN-GEN-REP-HER-00025

November 2021



Revision	Production Date	Prepared by	Checked by	Approved for release by	Sections revised
1.0	December 2020	Victoria Green Oxford Archaeology	Edward Biddulph, Senior Project Manager, Oxford Archaeology	Internal review only	
1.1	January 2021	Revised by Edward Biddulph, Senior Project Manager, Oxford Archaeology	Steve Lawrence, Senior Project Manager, Oxford Archaeology		
2.1	November 2021	Revised by Kate Brady Project Officer Oxford Archaeology	Martyn Allen, Senior Project Manager, Oxford Archaeology	Tim Allen and Steve Lawrence, Senior Project Managers, Oxford Archaeology	Additional data added to section 4, revision of section 5 and figures

This Evaluation Report has been prepared for Highways England in accordance with the terms and conditions of appointment stated in the Lower Thames Crossing (LTC) Technical Partner Contract. LTC cannot accept any responsibility for any use of or reliance on the contents of this document by any third party.

Contents

Section	Page
Summary	9
Acknowledgements	11
1 Introduction	12
1.1 Project details and scope of work	12
1.2 Location, topography and geology	13
1.3 Previous investigations	13
1.4 Archaeological and historical background.....	13
2 Project Aims	20
2.1 General aims	20
2.2 Specific objectives	21
3 Methodology	22
3.1 Constraints.....	22
3.2 Methodology for the evaluation	22
4 Results	23
4.1 Introduction and presentation of results	23
4.2 General soils and ground conditions.....	23
4.3 General distribution of archaeological deposits	24
4.4 Trenches 1-3 and 8-9 (Fig. 6)	24
4.5 Trenches 4-5 and 11-13 (Fig. 7)	25
4.6 Trenches 6, 7 and 16 (Figs 8 and 9).....	26
4.7 Trenches 18 and 25-27 (Figs 10 and 12).....	27
4.8 Trenches 20, 22, 28 and 30 (Figs 11 and 12).....	27
4.9 Trenches 32, 34, 35, 47 and 49 (Figs 13 and 14)	28
4.10 Trenches 72, 84, 85, 100 (Figs 15 and 16).....	29
4.11 Trench 107 (Figs 17 and 18).....	29
4.12 Trenches 68, 77, 86 (Figs 19 and 20).....	30
4.13 Trenches 51 and 104 (Fig. 2).....	31
4.14 Trenches 112, 114, 116, 119, 135, 140, 141 and 149 (Figs 21 and 22)	31
4.15 Trenches 156-160 (Figs 23 and 24).....	32
4.16 Trench 163 (Figs 25 and 26).....	33
4.17 Trenches 164, 167 and 172-173 (Figs 27 and 28).....	33
4.18 Trenches 168-170, 174-177 (Figs 29 and 31).....	34
4.19 Trenches 178-180 and 184-185 (Figs 30 and 31).....	35
4.20 Trenches 187, 189 and 190 (Fig. 32).....	36
4.21 Trenches 191, 198, 204-206, 208 and 214 (Figs 33 and 34)	36
4.22 Trenches 224, 227-232, 235 and 238 (Figs 35 and 36)	37
4.23 Trenches 240, 246, 247, 251 and 254 (Figs 37 and 38)	38
4.24 Trenches 262, 265, 267, 271,272 and 275-277 (Figs 39 and 40)	39
4.25 Trenches 284, 285 and 289-292 (Figs 41, 40 and 42).....	40
4.26 Trenches 293-295, 296-298 and 302-304 (Figs 44 and 45).....	41
4.27 Trenches 299, 307, 313, 314, 320 and 321 (Fig. 47).....	43
4.28 Trenches 310, 312, 316-319, 323 and 324 (Fig. 46).....	43

4.29	Trenches 326 and 328-332 (Figs 48 and 50).....	45
4.30	Trenches 334 and 335 (Figs 49 and 50).....	45
4.31	Trenches 338, 339 and 346-350 (Fig. 51).....	46
4.32	Trenches 342-344 (Fig. 52)	47
4.33	Undated and natural features	47
4.34	Finds summary	48
4.35	Environmental summary	49
5	Discussion	50
5.1	Reliability of field investigation	50
5.2	Interpretation.....	50
5.3	Evaluation objectives and results.....	55
Appendix A	Trench Tables	58
Appendix B	Finds Reports	202
Appendix C	Environmental Reports	227
Appendix D	References	235
Appendix E	Abbreviations and Glossary	238
Appendix F	Site Summary.....	239

Figures

Figure 1: Site location

Figure 2: Trenches 1-107, Land Parcel 41, Havering (LTC20): Trench layout showing cropmark features and archaeological features (overlying 1896 OS map)

Figure 3: Trenches 108-217, Land Parcels 41 and 42, Essex (LTC41N20): Trench layout showing cropmark features and archaeological features (overlying 1896 OS map)

Figure 4: Trenches 219-292, Land Parcels 60 and 44, Essex (LTC41N20): Trench layout showing cropmark features and archaeological features (overlying 1896 OS map)

Figure 5: Trenches 293-350, Land Parcels 60 and 44, Essex (LTC41N20): Trench layout showing cropmark features and archaeological features (overlying 1896 OS map)

Figure 6: Plan of Trenches 1-3 and 8-9

Figure 7: Plan of Trenches 4-5 and 11-13

Figure 8: Trenches 6, 7 and 16

Figure 9: Sections (Trenches 6 and 7)

Figure 10: Plan of Trenches 18 and 25-27

Figure 11: Plan of Trenches 20, 22, 28 and 30

Figure 12: Sections (Trenches 26, 28 and 30)

Figure 13: Plan of Trenches 32, 35, 47 and 49

Figure 14: Sections (Trenches 32, 35 and 49)

Figure 15: Plan of Trenches 72, 84, 85 and 100

Figure 16: Sections (Trenches 72, 84 and 85)

Figure 17: Plan of Trench 107

Figure 18: Sections (Trench 107)

Figure 19: Plan of Trenches 68, 77 and 86

Figure 20: Sections (Trenches 77 and 86)

Figure 21: Plan of Trenches 112, 114, 116, 119, 135, 140, 141 and 149

Figure 22: Sections (Trenches 135, 141, 149)

Figure 23: Plan of Trenches 156-160

Figure 24: Sections 15600, 15700, 15701, 15702, 15801,

Figure 25: Plan of Trench 163

Figure 26: Sections 16300, 16302

Figure 27: Plan of Trenches 164, 167, 172 and 173

Figure 28: Sections 17200, 17201, 17301

Figure 29: Plan of Trenches 168-170 and 174-177

Figure 30: Plan of Trenches 178-180 and 184-186

Figure 31: Sections 17600, 17900

Figure 32: Plan of Trenches 187, 189 and 190

Figure 33: Plan of Trenches 191, 198, 204-6, 208 and 214

Figure 34: Sections (Trenches 206, 208, 214 and 191)

Figure 35: Plan of Trenches 224, 227-32, 235 and 238

Figure 36: Sections (Trenches 224 and 235)

Figure 37: Plan of Trenches 240, 246, 247, 251 and 254

Figure 38: Sections (Trenches 240, 246 and 254)

Figure 39: Plan of Trenches 262, 265, 267, 271-2 and 275-7

Figure 40: Sections (Trenches 262, 267, 272, 276 and 285)

Figure 41: Plan of Trenches 284-5 and 289-92

Figure 42: Sections (Trenches 289, 290 and 291)

Figure 43: Results of geoarchaeological investigation

Figure 44: Plan of Trenches 294-298

Figure 45: Sections (Trenches 295 and 298)

Figure 46: Plan of Trenches 310, 312, 316-319, 323 and 324

Figure 47: Plan of Trenches 299, 306, 307, 313, 314, 320 and 321

Figure 48: Plan of Trenches 326 and 328-332

Figure 49: Plan of Trenches 334 and 335

Figure 50: Sections (Trenches 332, 334 and 335)

Figure 51: Plan of Trenches 338, 339 and 346-349

Figure 52: Plan of Trenches 342-344

Plates

Plate 1: West facing section 6800 through kiln structure 6808

Plate 2: West facing section 7200 through pit 7202

Plate 3: South-east facing section 7700 through layer 7704

Plate 4: South facing section 8400 through boundary ditch 8402

Plate 5: North facing section 10701 through boundary ditch 10704

Plate 6: South facing section 13500 through pit 13503

Plate 7: North-east facing section 14900 through ditches 14902 and 14905

Plate 8: NNW facing section 20600 through ditch 20604

Plate 9: North-west facing section 22400 through ditch 22403

Plate 10: North facing section 24000 through pit 24003

Plate 11: South facing section 24600 through pit 24603

Plate 12: North facing section 25400 through ditch 25403

Plate 13: East facing section 26701 through posthole 26706

Plate 14: North-east facing section 27601 through ring gully 27607

Plate 15: North-west facing section 28500 through ring ditch 28503

Plate 16: West facing view of Trench 208

Tables

Table 1: Prehistoric pottery from LTC20

Table 2: Prehistoric pottery from LTC41N20

Table 3: LTC20 - Quantification of late Iron Age and Roman fabrics

Table 4: LTC4120 - Quantification of late Iron Age and Roman fabrics

Table 5: LTC20 - Description of post-Roman pottery by context

Table 6: LTC41N20 - Description of post-Roman pottery by context

Table 7: Quantification of the LTC20 flint assemblage

Table 8: Quantification of the LTC41N20 flint assemblage

Table 9: LTC20 - Summary of CBM assemblage

Table 10: LTC41N20 - Summary of CBM assemblage

Table 11: Catalogue of metal objects by context

Table 12: Catalogue of glass by context

Table 13: LTC20 - Assessment of CPR samples

Table 14: LTC41N20 - Assessment of CPR samples

Table 15: Sheep skeletal elements from context 508

Summary

Oxford Cotswold Archaeology was commissioned by Balfour Beatty to undertake a trial-trench evaluation of Land Parcels 41, 42, 44 and 60 covered by WSI F of the Lower Thames Crossing Pre-Enabling Works. The northern part of Parcel 41 is located in the historic parish of North Ockendon in the London Borough of Havering. Parcels 42, 44 and 60, and the southern part of Land Parcel 41, are in the historic parish of South Ockendon in Thurrock unitary authority within the county of Essex (NGR 559121, 183872). A total of 346 trenches representing a 4% sample of the accessible areas were excavated and recorded between 16th September and 28th October 2020 and between 25th May June and 2nd of July 2021.

The trenches revealed only sparse artefactual evidence for earlier prehistoric activity in the form of scattered struck flints of later Mesolithic or early Neolithic date and a single sherd possibly of Beaker or early Bronze Age date. Two large penannular cropmark enclosures potentially of earlier prehistoric date were targeted, and both revealed corresponding soilmarks; one was shallow and there were no finds, while the other was only minimally sampled as it was judged to be of natural origin.

Later Bronze Age or Iron Age activity was more prevalent, pottery of these periods being found both in pits and ditches, including a possible small rectilinear enclosure in the north-west part of the site, but some of the pottery was residual in later features. Further south, a group of ditches running ENE and containing later prehistoric pottery corresponded to a cropmark ditch, and probably relate to cropmark trackways or droeways and an enclosure outside the site to the west. The cropmarks of a ring ditch 15m across and a semi-circular larger enclosure may also be related, although the only dating evidence from them was a single struck flint. A few features contained definitely Iron Age pottery, including one example of an early Iron Age expanded rim.

Late Iron Age or early Roman pottery was found in ditches in several trenches in the north-west of the site, possibly peripheral to a focus beyond the site. In Land Parcel 60 west of the B186 a cluster of discrete cropmarks thought to represent pits, a ring ditch 10m in diameter and an arc of gully were targeted, but although the cropmark ring ditch was encountered and excavated, this did not contain dating evidence, and neither the arc of gully nor the discrete cropmarks that lay within the trenches proved to be genuine features. While the ring ditch may be later prehistoric, several arcs of curvilinear gully indicating enclosures of similar size were revealed in adjacent trenches, one of which contained a sherd of Roman pottery, and two ditches in neighbouring trenches possibly belonging to one system also contained Roman pottery, perhaps indicating a focus of early-middle Roman activity here. The paucity of finds suggests that this was not domestic in character. Later Roman activity was evident from a few sherds in the south-eastern part of the site, but otherwise Roman finds were sparse.

Evidence for Saxon activity was restricted to the east end of the site. A ditch in the north-east corner contained six sherds of Anglo-Saxon pottery, and another ditch in the far south-east of Land Parcel 44 produced another two sherds. Medieval activity was found in two main areas. In the northern part of Land Parcel 41, pottery recovered from field boundaries was dated to the late Saxon or Norman period. Clearer evidence of domestic activity here is evident in the 13th-14th centuries, with ditches and pits in several trenches along the north edge of the site that contained sizeable assemblages

of domestic pottery and environmental remains including charcoal, cereals and weed seeds. Although no structural evidence was seen, this activity is likely to be very close to a focus of settlement of this date, probably the medieval manor and surrounding settlement of North Ockendon. In the south-east corner of Land Parcel 60, to the west of the B186, 13th/14th-century ditches may indicate a rectilinear enclosure.

At the western edge of Land Parcel 41, near to North Ockenden, two trenches revealed evidence for industrial activity dating to the 15th or 16th century. The precise nature of the industry is unclear, although the remains and field-name evidence indicates brick production from this period, with a possible brick clamp or kiln debris being recorded. Brick production at this location may have contributed to the construction of North Ockendon Hall.

In the post-medieval period, the site appears to have been used mainly for agriculture, with numerous boundary ditches and drainage features installed across the fields. Occasional ponds may have originated as localised quarries, or may indicate that part of the site was used as pasture.

Acknowledgements

Oxford Cotswold Archaeology would like to thank the client, Balfour Beatty, for commissioning this project and managing the site safety and attendances. Thanks are also extended to the Historic Environment Consultants (Richard Havis and Katie Lee-Smith) of Place Services at Essex County Council, who advised the Borough of Thurrock, and Adam Single of Historic England, who advised the London Borough of Havering, for monitoring and providing advice throughout the project.

The project was managed for Oxford Cotswold Archaeology by Steve Lawrence. The fieldwork was directed by Mark Dodd, and the 2020 evaluation was supervised by Victoria Green and Anne-Laure Bollen, who were supported by Rachel Alexander, Eilidh Barr, Charlotte Brown, Ellie Brown, Thomas Bruce, Alex Capon, Stephen Forster, George Gurney, João Heitor, Kerree Kendall, Meagan Mangum, Heloise Meziani, Nat Pacholek, Richard Spencer, Jason Stewart, and Katherine Whitehouse. The 2021 fieldwork was supervised by Jack Easen and Kat Whitehouse, who were supported by Rose Britton, Alex Capon, Jessica Domiczew, Stephen Foster, Nathan Griggs, Chris Griffiths, Kerree Kendall, Tim Lewis, Bethan Morgan, Tanja Peter, Marionna Sandin-Catcora and Molly Vowles. Site survey was undertaken by Caroline Souday and digitising was carried out by Gary Jones and Sophie Lamb.

Thanks are also extended to the teams of OA staff that cleaned and packaged the finds under the management of Leigh Allen, Geraldine Crann and Natasha Dodwell, processed the environmental remains under the management of Rebecca Nicholson and Natasha Dodwell, and prepared the archive under the management of Nicola Scott.

1 Introduction

1.1 Project details and scope of work

- 1.1.1 The Lower Thames Crossing Project is located between the A2 in Kent and the M25 in the London Borough of Havering. It will extend beneath the River Thames through a tunnel and emerge on the northern side of the river at East Tilbury. From the North Portal, the road will extend to the M25 at Junction 29 via the A13 and pass between North and South Ockendon. The development of the project is managed by LTC, a partnership between Highways England and a consultancy joint venture set up to oversee the scheme.
- 1.1.2 A programme of archaeological trial trenching commenced in the Essex part of the scheme in November 2019. A scheme-wide specification for trial trenching was written by LTC (Highways England 2018), and in July 2019, LTC commissioned Balfour Beatty to deliver the pre-enabling Works. Balfour Beatty appointed Oxford Archaeology (OA) to prepare a project-wide written scheme of investigation (WSI) for the scheme, which (at the request of the key archaeological stakeholders) is divided into two parts, one for the Kent section, and another for Essex and Havering (OA 2019a; 2019b).
- 1.1.3 Following completion of the project-wide WSIs, OA was instructed to prepare a series of site-specific or group-site specific WSIs for approval by the key archaeological stakeholders in advance of trial trenching to inform the Development Consent Order (DCO). The northern part of Parcel 41 is located in the historic parish of North Ockendon in the London Borough of Havering, while Parcels 42, 44 and 60, and the southern part of Land Parcel 41, are in the historic parish of South Ockendon in Thurrock unitary authority within the county of Essex (Fig. 1) (NGR 559121, 183872). A detailed WSI was created for the land parcels prior to the trial trenching (WSI F, OA 2019c), which details the archaeological background and the potential for the survival of remains within the site. It also sets out the archaeological aims and objectives appropriate to the investigation of these land parcels by trenching and has described the methodology to be applied. The WSI was approved by Richard Havis, Principal Historic Environment Consultant for Place Services at Essex County Council, and by Adam Single of Greater London Archaeological Advisory Service (GLAAS) prior to the start of the fieldwork. Oxford Cotswold Archaeology was commissioned as Balfour Beatty's archaeological contractor to undertake the evaluation in accordance with the approved WSI and local and national planning policies.
- 1.1.4 The fieldwork was completed between 16th September and 28th October 2020 and between 25th May and 2nd July 2021. All work followed the MoRPHE Project Manager's guide (Historic England 2015), and the Code of Conduct of the Chartered Institute for Archaeologists (CIfA). The archaeological works adhered to the standards and guidance for archaeological evaluation, excavation and archiving (CIfA 2014a; CIfA 2014b).

- 1.1.5 The work was monitored by Richard Havis and Katie Lee-Smith of Place Services on behalf of the Borough of Thurrock, and by Adam Single on behalf of GLAAS for the London Borough of Havering.

1.2 Location, topography and geology

- 1.2.1 Land Parcels 41-42, 44 and 60 (WSI F), hereafter referred to as the 'site' within the boundary of the scheme, are located in the historic parish of North Ockendon in the London Borough of Havering and South Ockendon in Thurrock unitary authority within the county of Essex (Fig. 1) (NGR 559121, 183872). The majority of the southern part of the site (Land Parcels 42, 44 and 60) is located within the historic parish of South Ockendon and the north-western part of the site (Land Parcel 41) is located in the historic parish of North Ockendon. The village of North Ockendon is adjacent to and north of the site, while the town of South Ockendon is adjacent to and south of the site. The site is roughly J-shaped and covers an area of 60.178ha. The site is bounded to the west by a branch line of the London, Tilbury and Southend Railway. To the south, east and north, the site is bounded by agricultural fields. Several houses are located directly north of the site along North Road (B186) which bisects the site. The site is also located just south-west of the site of North Ockendon Hall, now Hall Farm.
- 1.2.2 The bedrock geology of this site is London Clay Formation (clay, silt and sand). The superficial geology is mixed, the majority of the site sitting on head deposits (clay, silt, sand and gravel) and the edges of the site upon the Boyn Hill Gravel Member (sand and gravel). The colluvial layer of head was formed by fine-grained materials collecting on slopes and at the base of a slope (BGS 2020).
- 1.2.3 The site is currently in use as part of 12 arable fields located east and west of North Road (B186). Within the 1km study area, land use is mostly agricultural with a small amount of urban development associated with North and South Ockendon.
- 1.2.4 The site lies on the slope of a plateau that is situated on the western edge of the Mardyke valley. The River Mardyke is located 2.5km south-east of the site. The northern edge of the site is situated on the edge of a plateau where the terrace lies at a height of c 24-5m aOD. The ground slopes downwards to the south and west to c 18-19m aOD. Colluvial head deposits have accumulated along the slopes of the terrace.

1.3 Previous investigations

- 1.3.1 There have been several archaeological investigations within the area of the site, which are discussed below. The site itself has not seen any modern development.

1.4 Archaeological and historical background

- 1.4.1 The chronological summary of known archaeology given below is taken from the detailed WSI for Land Parcels 41, 42, 44 and 60. Cropmarks within the site boundary are shown on Figures 2-5.
- 1.4.2 Palaeolithic. No Palaeolithic finds have been recorded within the site or within a 0.8km radius of the site.

- 1.4.3 Palaeolithic finds have been recorded at the northern and south-eastern edge of the 1km study area, located 800m north and 800m south-east of the site respectively.
- 1.4.4 Mesolithic. No known Mesolithic flints have been recorded within the site, and only one microlith and one blade from the 1km study area, both to the south-west along the M25 (Biddulph and Brady 2015).
- 1.4.5 Neolithic. No Neolithic features or finds have been recorded within the site, or the 1km study area. Several struck flints of late Neolithic or early Bronze Age date were recovered from an area alongside the M25 just under 1km to the south-west (ibid.).
- 1.4.6 Early Bronze Age. Several cropmarks of ring ditches were identified within the area of the site, including one within Land Parcel 42 (Aerial Mapping Report site 6; Place Services 2019) and one within Land Parcel 60 to the south of the site (Aerial Mapping Report site 5B). Both ring ditches are small, around 10m in diameter. It is possible that these features represent ploughed-out round barrows of the early Bronze Age date, although small ring ditches such as these are more commonly burial sites of the later Bronze Age.
- 1.4.7 Later Bronze Age and Iron Age. A series of cropmarks have been identified by the HER and by the aerial survey south of Hall Farm (Aerial Mapping Report sites 6 and 5A) and either side of North Road, north of South Ockendon (Aerial Mapping Report sites 7A, 7B, 8 and 9 and 68). These cropmarks include two penannular enclosures within the area of the site. The larger of these enclosures is 45m across and located partly within Land Parcel 60 in the north-eastern part of the site (Aerial Mapping Report site 8). This enclosure may be associated with several linear features to the north. The smaller penannular enclosure within Land Parcel 44 is 20m in diameter and has a possible entrance to the north (Aerial Mapping Report site 68). These enclosures may date to the later Bronze Age and Iron Age.
- 1.4.8 Other cropmark features within the area of the site include the ring ditches mentioned above. These small ring ditches may in fact represent Bronze Age or Iron Age roundhouses rather than burial monuments. There are also scatters of possible pits and a short linear feature within the southern part of the site, which may be associated with the ring ditches in this area (Aerial Mapping Report sites 7B and 9). Several other features are also located within the southern part of the site (Land Parcel 42), including several linear features and a semi-circular feature (Aerial Mapping Report site 6). While not dated, the character of the enclosures, particularly the penannular examples, suggests a later prehistoric date.
- 1.4.9 Several cropmark features are located just outside the boundary of the site, including a rectangular enclosure over 60m long and a ring ditch feature (site 5A), a square enclosure 25m across (site 7A), together with partial enclosures of similar shape and dimensions (sites 5A and 7A). An Iron Age ditch was recorded just east of site 5A, and adjacent to the current site, which suggests a possible date for the features nearby. A probable Bronze Age cremation burial was recorded during archaeological watching briefs on the Horndon to Barking pipeline c 200m north of the site (Birbeck and Barnes 1994), perhaps indicating a Bronze Age date for some of the adjacent cropmarks, and a middle Bronze Age vessel was recovered from a pit just 180m west of the site

during construction of a pond just east of the M25 and just north of Dennis Road (Biddulph and Brady 2015). Scattered Bronze Age activity is clearly evident over a wide area here. Residual Bronze Age and Iron Age pottery was recovered from a mound 300m of South Ockendon Old Hall, located 900m south-east of the site, which was the second of three Roman barrows once present in this area. Six hundred metres to the east of the site a ditch containing late Bronze Age finds was found during the Horndon to Barking pipeline within the scheme area (Birbeck and Barnes 1994), and a middle Bronze Age pit was found 900m to the south-west alongside the M25 (Biddulph and Brady 2015).

- 1.4.10 Roman period. No Roman features or finds have been recorded within the site, although some Roman activity has been recorded within the 1km study area in the form of a late Iron Age to late Roman site and three Roman burial mounds.
- 1.4.11 A late Iron Age–late Roman site was excavated 0.5km west of the site. This excavation recorded five cremation burials and two pits of early Roman date. There was evidence for later Roman activity in the form of pits, gullies and enclosure ditches, with some containing slag and burnt clay (Howell et al. 2011).
- 1.4.12 In 1957, a burial mound was excavated 0.6km south-east of the site and 260m north-east of South Ockendon Hall. The trench through this barrow found 17 sherds of Roman pottery, although the central burial was not disturbed. This barrow is situated on the high ground of the terrace edge on the western side of the Mardyke valley. It may have been one of three barrows which were 500m apart. A second barrow was located c 400m south of the scheduled barrow, and the location of the third barrow (now destroyed) is uncertain. The second barrow was excavated prior to being destroyed and the finds dated to the late 2nd century AD. An east-west trackway and other linear features that may be Roman in date were identified north of South Ockendon Hall by the aerial mapping survey (Aerial Investigations and Mapping Report site 9).
- 1.4.13 Medieval period. No Saxon features or finds have been recorded within the site, but late Saxon or medieval features were found only 150m to the west during construction of a pond adjacent to the M25 (Biddulph and Brady 2015). Documentary evidence suggests that this area was occupied during the Saxon period, and by the late Saxon period was very likely part of the manorial estate of North and South Ockendon. The Domesday survey notes that North and South Ockendon was very large for the period with 90 households (Palmer 2019).
- 1.4.14 No medieval activity is known within the site, but the linear features (Aerial Mapping Report site 5B) identified within Land Parcel 41, in the north-western part of the site, and some of the discrete features in Land Parcel 60 within the southern part of the site (Aerial Mapping Report site 5B), may be attributed to this period. These features are discussed in more detail below.
- 1.4.15 The roads within this part of the scheme appear to have a roughly NNW-SSE and east-west alignment, and this could relate to the formation of the parishes or the use of more ancient droveways. The medieval road network is probably much the same as that shown on the first edition Ordnance Survey (OS) map of 1805, as the area remained undeveloped into the 20th century (VCH 1978).

This map shows the north-south road (North Lane) from Puddle Dock to North and South Ockendon (now the B186) which bisects the site. Fen Lane, aligned east-west and located 500m north-east of the site, linked North Ockendon to the village of Bulphan.

- 1.4.16 The major areas of settlement in the vicinity of the site in the later medieval period may have been along North Road (now the B186) and around the medieval parish churches of St Nicholas in South Ockendon and St Mary Magdalene in North Ockendon. In addition, there is likely to have been a cluster of settlement activity around the manors of North Ockendon Hall and South Ockendon Hall. This part of Essex is generally characterised by a settlement pattern of dispersed farms and hamlets and so there may have been a number of these close to the site (Bennett 2011). It is possible that farmsteads were located along North Lane (Land Parcel 60) and that some of the discrete features in this area (Aerial Mapping Report site 5B) are medieval in date, perhaps associated with dispersed settlement activity.
- 1.4.17 The Grade I listed Church of Mary Magdalene is located c 200m north-east of the site on the gravel terrace south of the northern Mardyke valley in the parish of North Ockendon. The church has elements of 12th-century architecture and presumably dates from this period. The church may have been the focus of the medieval settlement of North Ockendon, which may have been located around the church. A T-shaped moat is still extant south of the church and just east of the site and this may have been associated with a medieval manor house (Aerial Mapping Report site 4). It is unclear whether the moat originally extended further west. The medieval manor of Ockendon Setfountayns was formed in the early 13th century and it may have been located in the area of the post-medieval North Ockenden Hall, which was damaged in the Second World War by bombing and was later demolished (VCH 1978).
- 1.4.18 Several cropmarks extend southwards from Hall Farm and may be associated with a medieval settlement at North Ockendon. This includes six linear features aligned NNW-SSE within the northern part of the site (Aerial Mapping Report site 5B). These may be field boundaries of later medieval or early post-medieval origin, as apart from one they do not appear on the 19th century OS maps. In addition, a possible trackway associated with a rectangular enclosure over 60m long extends south of Hall Farm. Medieval features indicative of settlement activity were excavated near Dennises Farm located just west of the site. Four ditches were recorded along with two pit complexes containing 12th- to 13th-century pottery (Wilkinson 1988). This settlement may have been a medieval farmstead which was located just south of a green lane and a later building shown on the 1841 North Ockendon Tithe map. This green lane linked North Ockendon Hall with Pea Lane to the west before it was cut in the later 20th century by the M25. The green lane passed through the northern part of the site (Land Parcel 41) and was extant until the mid-19th century.
- 1.4.19 The church of St Nicholas in South Ockendon is located 800m south of the site and dates from the 12th century (VCH 1978). The nucleated settlement of South Ockendon was likely to have been located around this church and farmsteads scattered throughout the parish.
- 1.4.20 A medieval moated manor was located at South Ockendon Hall located 0.6km south-east of the site, which is now scheduled. The manor here was known

as 'of Bruyns' and was certainly established by the 12th century but may have late Saxon origins. This manor house may have been rebuilt several times during the post-medieval period. An east-west trackway was identified by the aerial survey to the north of the hall along with a rectangular enclosure. It is possible this track could be medieval or earlier in date (Aerial Mapping Report site 9). This manor was split in the early 16th century and the manor of Groves was created to the north (VCH 1978).

- 1.4.21 Post-medieval period. A medieval or post-medieval manor house is likely to have been located within Land Parcel 60, the easternmost part of the site and this is discussed in detail below. Documentary evidence also suggests that a post-medieval brick kiln was located within Land Parcel 41 in the western part of the site. In addition, linear features identified within Land Parcel 41 may be post-medieval field boundaries (Aerial Mapping Report sites 5B, 6, 7C, 8, 9).
- 1.4.22 During the later post-medieval period the road network in the area of the site probably continued without significant change from that of the later medieval period. In relation to the principal estates of this period, the land parcels covered by WSI F are located south of North Ockendon Hall, south of Grove Farm and Groves Barns, and north-west of South Ockendon Hall in the parish of South Ockendon. Apart from the construction of the Upminster and Grays branch railway in the later 19th century, this area retained a largely rural character with dispersed settlements along key roads. In the later 20th century, the M25 was constructed directly north-west of the site and South Ockendon expanded northwards along the B186.
- 1.4.23 The tithe map for North Ockendon (c 1841) indicates that the north-western part of the site was owned by Richard Benyon of North Ockendon Hall. There is nothing left above ground of North Ockendon Hall apart from the medieval moat and garden walls relating to the c 16th-century North Ockendon House. As mentioned above the North Ockendon tithe map shows a green lane within Land Parcel 41 bisecting the site which linked North Ockendon Hall to Dennises Farm. The northernmost field of the site, and north of the green lane was known as Well Field and was in arable use.
- 1.4.24 The field to the south of the green lane within the site was known as Brickclamps but was in arable use. In the late 18th century this field was also known as Brick Kiln Field and is named as such on an estate map of dating to 1779, when the estate was known as North Ockendon Hall Farm. This suggests that this field was used for brickmaking in the later 18th century, but that this had ceased by the mid-19th century. The name given on the tithe map probably indicates that the kiln or kilns were clamp kilns, rather than more permanent structures, and they had been truncated to some degree by later ploughing. The aerial survey noted several cropmarks within these fields, and these are field boundaries shown in the 1841 tithe map.
- 1.4.25 The 1779 map labels the southernmost field of the estate (two fields south of the brick clamps 1811) as 'Sand Pit Field', so this was probably a sand extraction pit. Other sand pits are located north-east of the main house. Another field east of Brick Kiln Field (and outside the scheme limits) is known as Duck pits, and this suggests further quarrying, perhaps for clay. The BGS boreholes indicate that sand and clay can be accessed at shallow depths in this area (less than 3m) and so clay may also have been obtained from the

sand pits for making bricks. The tithe map for North Ockendon (c 1841) shows that by this date Sand Pit Field was used as an arable field. There is a small wood marked on the estate map of 1779 in the field between this and Brick Kiln Field where wood for firing may have been obtained, and another field east of this (partly within the scheme) is called Kings Wood field, suggesting former woodland here as well.

- 1.4.26 The former later medieval or early post-medieval moated manor of Groves Barns is probably located adjacent to the eastern part of the site. This manor may have been established c 1531 when the manor of Bruyns (South Ockendon Hall) was split, or there may have been an earlier building on this site. This manor house was recorded as having 22 hearths in 1670, which was the largest number of hearths for South Ockendon parish and was therefore a substantial manor house. This manor house was extant until at least c 1772 but was demolished soon after (VCH 1978). The only remains of this manor house above ground comprise a late 16th-early 17th century gateway and wall, now grade II listed and located c 100m north of the site.
- 1.4.27 The tithe map for South Ockendon (c 1840) shows several possible fishponds in the woodland within the most easterly part of the site. The most northerly fishpond is still extant and the tithe map shows that this led southwards to a rectangular pond with two further streams leading south. The large rectangular pond has a possible building located on a small circular island within the north-eastern corner. This area is difficult to make out from the tithe map, and it is possible that this is not a building but large tree; this field is only described as wilderness in the apportionment. A site visit in 1992 identified several earthworks and areas of the former fishponds. The aerial survey did not identify any features related to the manor house, but this may have been because part of the manor is now situated in an area of woodland.
- 1.4.28 The tithe map for South Ockendon (c 1840) indicates that most of the eastern part of the site (apart from the south-east corner) was owned by the estate of John Henry Stewart of the manor of Groves. Several of the field boundaries that are shown on the OS map of 1896 are also shown on the c 1840 tithe map. Groves Farm (still extant) was also located on the Groves manor estate. This 19th-century farm building is located east of the B186 and 100m north of the site.
- 1.4.29 The south-eastern part of the site was owned by the estate of John Cliff of South Ockendon Hall. The boundary between the manors of Groves and South Ockendon Hall was the ENE-WSW field boundary to the south of the woodland within the south-eastern part of the site. The cropmark of one field boundary shown on the tithe map was associated with South Ockendon Hall. This field boundary was removed by the later 19th century (Aerial Mapping Report site 9).
- 1.4.30 Undated features and cropmarks. Apart from the linear features within the site (which are likely to be of medieval and post-medieval date) there are also a number of discrete pit-like features and ring ditches that were identified from cropmarks within Land Parcel 60 (Aerial Mapping Report site 5B). The ring ditches are likely to be prehistoric, although other dates including medieval and post-medieval are also possible; the cropmarks that has been identified within this area may prove to be prehistoric or medieval in date and are

discussed in these period sections above. It is also possible, however, that some of the discrete features may be geological in origin.

2 Project Aims

2.1 General aims

2.1.1 The general aims of the project were as follows:

- i. To establish the presence or absence of archaeological remains along the line of the scheme, and the extent of any areas where remains appear likely to be absent.
- ii. In areas where archaeological remains are known or suspected, to clarify the reliability of the cropmark or geophysical survey evidence.
- iii. In areas where no archaeological remains are indicated by aerial or geophysical survey, to clarify whether this apparent absence of remains is genuine.
- iv. To determine the degree of complexity of any surviving horizontal or vertical stratigraphy, and in particular, to investigate areas where topography indicates the likelihood of deep deposit sequences for evidence of buried archaeological horizons and palaeo-environmental sequences.
- v. Where remains are present, to determine the period(s) represented, the extent, state of preservation and character of the archaeological remains.
- vi. To establish the range and state of preservation of archaeological artefacts, and through their recovery and examination, to establish the potential for information about the economy, status and contacts of past inhabitants of the scheme footprint.
- vii. To determine whether palaeo-environmental remains are preserved, and, where these are found, to determine their types (e.g. charred plant remains, waterlogged remains, molluscan remains), state of preservation and potential for environmental information. This will be achieved through the recovery of samples from sedimentary sequences and archaeological features suitable for assessment of a range of palaeoenvironmental remains (e.g. charred and waterlogged plant remains, charcoal, insects, pollen, diatoms, ostracods/foraminifera and molluscs) and scientific dating (e.g. radiocarbon and OSL dating).
- viii. To investigate and record the extent, character and chronology of the sedimentary sequences, in particular those immediately adjacent to and in floodplains, contained within palaeochannels or in dry valleys, and to use the data to refine existing geoarchaeological (predictive) deposit models.
- ix. To place any identified archaeological remains into their local and, where appropriate, regional or national context, and to assess the implications of any such discoveries for our current understanding of settlement and landscape change in the area, including an assessment of the associations of any remains with reference to the historic landscape.
- x. To provide sufficient information to enable the LTC archaeological advisor, in consultation with the Key Archaeological Stakeholders, to determine the significance of the archaeological assets identified within the site.

- xi. To provide a report on the discoveries to inform the Environmental Statement (ES) supporting the Development Consent Order (DCO) and support the preparation of a further archaeological mitigation strategy for the Enabling Works and Construction phases of the scheme.
- xii. Following the DCO, to deposit the report in the public domain, and to generate an accessible and useable archive which will allow future research to be undertaken.

2.2 Specific objectives

2.2.1 The specific project objectives were as follows:

- xiii. To conduct the programme of archaeological investigation within the general research parameters and objectives defined by the revised East of England Research Framework (Medlycott 2011)
- xiv. To clarify whether the circular ring ditches are the remains of burial monuments or 'shrines' of the Bronze Age, and if so, to establish their date and duration of use within and beyond the period;
- xv. To establish whether settlements and burial monuments of the Bronze Age are contemporary, and in particular, whether occupation evidence is associated with the ring ditches that may represent either burial monuments or roundhouses;
- xvi. To clarify whether the cropmarks provide an accurate representation of the range, quantity and types of archaeological features present within the parcel;
- xvii. To establish the character and date of the cluster of discrete pits within the southern part of Land Parcel 60, and to determine whether these are all of one type or period, or whether they encompass several types and span several periods of activity;
- xviii. To establish the date of the possible medieval or post-medieval field boundaries that have been identified within the site;
- xix. To establish the presence or absence of a possible medieval or post-medieval green lane within the northern part of Land Parcel 41;
- xx. To establish whether there is any surviving evidence for brick making within the western part of the site, and if so, to clarify the date of origin of this activity and chart its development;
- xxi. To establish the extent (and depth) of clay and sand extraction within the north-western part of the site associated with 18th-century (or earlier) brickmaking;
- xxii. To establish the presence or absence of medieval and post-medieval farmsteads which may have been located within the site;
- xxiii. To establish the presence of the medieval or post-medieval manor of Groves within the eastern part of the site. This will not be assessed by trial trenching at this stage but will be investigated by additional measures at a later stage of works.

3 Methodology

3.1 Constraints

- 3.1.1 Several constraints limited the area of the site available for trial trenching. These included live services such as gas and electricity and ecological constraints.
- 3.1.2 These limitations were taken into consideration when designing the detailed trench layout, but the plotted positions of buried services are often only approximate. Due to this and to low-hanging overhead cables, it was necessary to adjust the locations of 17 trenches (37, 39, 77, 94, 95, 121, 127, 129, 255, 257, 274, 276, 277, 278, 279, 280 and 286). The excavation locations of all trenches are shown by their numbers in Figures 2-5.
- 3.1.3 Trenches 40, 41 and 103 were omitted due to wet ground conditions at these locations, and due to a minor amendment to the scheme boundary in 2021 Trench 218 was no longer required.

3.2 Methodology for the evaluation

- 3.2.1 The total land-parcel area was 59.78ha, and the area available for investigation excluding areas of services, hedgerows and other constraints was 47.55ha. A total of 350 trenches were allocated for excavation, each measuring 30m x 2m, representing a 4% sample of the area available for trenching. A total of 346 trenches was excavated.
- 3.2.2 The trench design was developed to target cropmark features identified by the aerial investigation and mapping report (Place Services 2019), and to provide even coverage of the blank areas. Trenches 6, 9, 13, 23, 24, 28, 30, 107, 149 and 140, 163, 208, 214, 284, 285, 286, 287, 328, 329, 330, 332, 334 and 344 targeted possible features (Figs 2-5).
- 3.2.3 All trenches were located using a Global Positioning System (GPS) prior to machine excavation. All trenches were excavated using a tracked excavator fitted with a toothless bucket under constant archaeological supervision.
- 3.2.4 Revealed features were hand cleaned and sampled by hand excavation. They were recording as outlined within the approved WSI. All finds were bagged by context throughout the evaluation and were recovered for further investigation. Soil samples were taken as appropriate.

4 Results

4.1 Introduction and presentation of results

- 4.1.1 The results of the evaluation are presented below and include a stratigraphic description of the trenches that contained archaeological remains. The full details of all trenches, with dimensions and depths of all deposits, can be found in Appendix A. Finds and environmental data are presented in Appendices B and C respectively.
- 4.1.2 Context numbers reflect the trench numbers, unless otherwise stated. The first numerals of a context number repeat the trench number and allow for a maximum range of 100 individual records for a single trench. For example, pit 7202 is a cut within Trench 72 and ditch 25407 is a cut within Trench 254. Thus, Trench 72 has a potential record number range of 7200-7299 and Trench 254 has a range of 25400-25499.
- 4.1.3 Because the site was split across two local authorities, the fieldwork was undertaken under two separate site codes in order to facilitate archiving, but the results have been amalgamated together for this report as they were part of the same WSI. Trenches 1 to 107 were part of Land Parcel 41 (north) and located in the London Borough of Havering and were recorded using the site code LTC20. Trenches 108 to 350 are spread across Land Parcels 41 (south), 42, 60 and 44. They fall within the unitary authority of Thurrock and are identified by code LTC41N20.

4.2 General soils and ground conditions

- 4.2.1 The soil sequence consisted of a mixed natural geology overlain by a relatively consistent layer of ploughsoil. In the southern part of the site there was a layer of subsoil below the ploughsoil and overlying the natural geology, but this was generally absent from trenches in the northern part of the site.
- 4.2.2 The ploughsoil comprised grey-brown clayey silt approximately 0.3m thick. The subsoil comprised greyish brown silty sand and clayey silt and was up to 0.25m thick. The thickest deposits of subsoil generally accumulated where dips in the topography occurred.
- 4.2.3 The variations in natural geology across the trenches were mapped by a team of geoarchaeologists to help refine the identification of Head deposits and assist in identifying Pleistocene sediments that might contain Palaeolithic material for future investigation. The results of these observations are shown in Figure 43. Some of the trenches could not be included, because not all were available at the time the mapping assessment was made.
- 4.2.4 Ground conditions throughout the 2020 phase of evaluation were poor, and the trenches were exposed to numerous episodes of heavy rainfall, and some trenches flooded before they had been fully excavated and recorded. The wet ground conditions also led to extended periods during which work was not permitted, which resulted in silting in the base of the trenches, reducing the visibility of the unexcavated features. Conditions in the 2021 phase were generally good, although wetter during the work in Land Parcels 60 and 44,

but this did not affect recognition, excavation or recording of archaeological features.

4.3 General distribution of archaeological deposits

- 4.3.1 Archaeological features were located in Trenches 1-7, 9, 11-13, 16, 22-28, 30, 32, 34-35, 47, 49, 51, 66, 68, 72, 77, 84-86, 100, 104, 107, 112, 114, 116, 119, 135, 140, 141, 149, 155-160, 163-164, 167-170, 172-173, 176, 177, 179-184-185, 187, 190-191, 198, 205, 206, 208, 214, 224, 227, 229-232, 235, 238, 240, 246, 247, 249, 251, 254, 262, 265, 267, 271, 272, 275-277, 284, 285, 289-292, 294-298, 302, 304, 307, 310, 312, 313, 314, 316-318, 321, 323, 324, 328, 331, 332, 334, 335, 338, 339, 343, 346, 347 and 349.
- 4.3.2 The evaluation confirmed the presence of several linear and curvilinear features within the site that had been identified as cropmarks by the aerial investigation and mapping report (Place Services 2019). These features comprised a possible trackway and field systems, as well as evidence of possible settlement activity in the east of parcel 60, close to the North Road.
- 4.3.3 Trenches that did not reveal any archaeological remains will not be discussed or illustrated further.

4.4 Trenches 1-3 and 8-9 (Fig. 6)

- 4.4.1 Trenches 1, 2 and 3 were located in the north-west corner of Land Parcel 41.
- 4.4.2 Trench 1 on the north-west contained four pits and a ditch. Pit 102 was located at the north-eastern end of the trench and measured 0.67m wide and 0.26m deep. It contained a single light grey-brown silty clay fill (103), which contained sherds of late Iron Age or early-middle Roman pottery. Adjacent pit 104 was similar in size, measuring 0.5m wide and 0.29m deep. Its light brownish-grey silty-clay fill (105) also produced sherds of the same date range, and was sampled for environmental remains (sample 4). The flot contained a fair quantity of charcoal, but few seeds, most of which appear to be modern.
- 4.4.3 To the west of the two pits was a N-S aligned ditch (106) which measured 1.68m wide and 0.4m deep. It contained a single fill of brownish grey sandy clay that was without finds. This ditch followed the same alignment as several N-S aligned cropmarks further to the east.
- 4.4.4 At the south-western end of the trench were two circular pits. Pit 108 was the more westerly and measured 0.79m wide and 0.25m deep. There were two fills, the earlier a thin lens of blue-grey silt-clay (109), from which environmental sample (sample 5) was taken, and the later a light brownish grey silty clay. Neither fill contained finds, but the environmental sample produced charcoal and charred hazelnut shell. Adjacent pit 111 measured 0.44m wide and 0.17m deep and was filled with a light grey-brown silty clay. This was also devoid of finds.
- 4.4.5 Trench 2 was located to the east of Trench 1 and contained a single pit (202). The pit was circular and measured 0.43m wide and 0.17m deep. Its grey-brown clayey silt fill did not contain finds.
- 4.4.6 Trench 3 was located to the east of Trench 2 and contained a single ditch. Ditch 302 was aligned N-S, and was aligned parallel with ditch 106 in Trench 1 and with a cropmark ditch 13m to the east of Trench 3.

- 4.4.7 Trench 9 lay to the south of Trench 1 and contained a deposit of building material/kiln debris (902). The deposit was spread over an area 2.36m in diameter and was 0.16m thick. The material consisted of dark grey-brown clayey silt with frequent inclusions of charcoal and broken-up 15th-16th-century brick fragments. A single sherd of flint-tempered pottery was recovered from the deposit and has been dated as prehistoric, and in this context is clearly residual.
- 4.4.8 Trench 8 was located to the east of Trench 9 and revealed three natural features (803, 804 and 805).

4.5 Trenches 4-5 and 11-13 (Fig. 7)

- 4.5.1 This group of trenches was located east of Trenches 1-3 and 8-10 in the north-western part of Land Parcel 41 adjacent to the northern site boundary. All were aligned either north-south or east-west.
- 4.5.2 Trench 4 was located to the east of Trench 3 and contained a single ditch. Ditch 403 was aligned roughly E-W and measured 0.8m wide and 0.24m deep. It contained a single grey-brown silty sand fill devoid of finds. No continuation of this ditch was seen in Trench 3 to the west.
- 4.5.3 Trench 5 was located to the east of Trench 4 and contained three ditches and three pits. Ditch 513 was located at the western end of the trench and was aligned N-S, on the same alignment as cropmark ditches outside the trench to the east and west, and roughly midway between them (30m to the east, 34m to the west). It measured 1.36m wide and 0.18m deep. The single fill of brownish-grey clayey sand did not contain finds.
- 4.5.4 Located 17m to the east and on a NNW-SSE alignment was a narrower ditch (511). The ditch measured 0.43m wide and only 0.08m deep and the single grey-brown clayey sand fill did not contain finds. To the east of the ditch was a very shallow possible pit (509). The relationship between the two features was unclear and the single grey-brown clayey silt pit fill was devoid of finds.
- 4.5.5 Three features in the eastern part of the trench dated to the medieval period. Ditch 502 was aligned WNW-ESE with a rounded terminus at the WNW end and measured 0.39m wide and 0.23m deep. Its single fill (503) contained 21 sherds of pottery dated to AD 1270-1350 and a nail. A sample (sample 6) was taken for environmental remains, and contained oak and cherry/blackthorn charcoal and seeds of wheat, oat and also charred legumes. To the north of ditch 502 was sub-oval pit 507. It measured 1m long, 0.65m wide and 0.18m deep and had a single grey-brown clayey sand fill (508) from which two sherds of pottery dated to AD 1270-1350 were recovered. Another pit (504) was partially revealed, located in the central part of the trench and partially extending beyond its southern side. The visible portion measured 0.64m wide and 0.24m deep. There were two fills, both greyish-brown clayey sands, and the upper of these (506) contained 23 sherds of pottery dated to AD 1100-1325. A sample (sample 7) was taken for environmental remains.
- 4.5.6 Trench 11 was located to the south of Trench 4 and contained two ditches. At the western end of the trench, ditch 1103 was aligned N-S and corresponded (although slightly offset to the west) with the location of a linear cropmark. The

ditch measured 1.06m wide and 0.27m deep and contained a single light brown-grey clayey silt fill that was devoid of finds.

- 4.5.7 Ditch 1105 had a terminus in the centre of the trench, from which it ran north-east. It measured 0.96m wide and 0.36m deep and contained two clayey silt fills, the upper of which contained a single sherd of pottery of later prehistoric date.
- 4.5.8 Trench 12 lay east of Trench 11 and south of Trench 5, and contained a single ditch towards its north end (1202). The ditch was aligned E-W and measured 2.24m wide and 0.12m deep. It contained a brownish-grey sandy silt fill that was devoid of finds.
- 4.5.9 Trench 13 was located to the east of Trench 12, and was positioned to cross a N-S linear cropmark. It contained two ditches and three small pits.
- 4.5.10 Ditch 1302 was revealed in the western end of the trench, and corresponded with the north-south linear cropmark. The ditch measured 3.04m wide and 0.61m deep. It contained a single brownish grey clay-silt fill (1303), from which 33 sherds of medieval pottery dating to AD1250-1300 were recovered. A sample was taken for environmental remains, but only produced a possible charred sedge seed (sample 9).
- 4.5.11 Another ditch (1304) was situated 5m to the east of ditch 1302. It was on the same N-S alignment and measured 0.79m wide and 0.19m deep. Its light brownish-grey silty clay fill was devoid of finds. This ditch was roughly in line with a second linear cropmark ditch to the south parallel to the one identified as ditch 1302, but which was not visible running as far north as Trench 13. It is possible that ditch 1304 was a continuation of this cropmark.
- 4.5.12 To the east of ditch 1304 were three pits, none of which contained finds. Pit 1306 was circular and measured 0.79m wide and 0.19m deep. Pit 1308 was sub-oval and measured 0.71m wide and 0.1m deep and both contained light grey-brown clayey silt fills. Pit 1310 was circular and measured 0.53m wide and 0.24m deep and contained two fills. Both were dark greyish-brown clayey silt fills, the earlier one of firm consistency, the later fill (1312) softer. A sample was taken from 1312 for environmental remains (sample 8).

4.6 Trenches 6, 7 and 16 (Figs 8 and 9)

- 4.6.1 Trenches 6, 7 and 16 were located in the north-east corner of Land Parcel 41, east of Trenches 5 and 13.
- 4.6.2 Trench 6 was located to cross a N-S linear cropmark, but instead revealed a single ditch aligned roughly E-W. The ditch (602) measured 1.3m wide and 0.21m deep and contained a single grey-brown clay-silt fill that did not contain finds (Fig. 9 section 600).
- 4.6.3 Trench 7 was located to the east of Trench 6 and contained a ditch on an ENE-WSW alignment (702), which measured 2.5m wide and 0.3m deep. Pottery from the single brown-grey sand-silt fill (703) consisted of five sherds dated to AD 1300-1400. This may be the same ditch as seen in Trench 6, as although on a slightly different alignment its projected line coincided with the easternmost exposure of the ditch in Trench 6, and it had a similar depth and wide irregular profile (Fig. 9 section 700).

- 4.6.4 Trench 16 was located to the south of Trench 7. It contained one ENE-WSW ditch (1603) extending across the middle of the trench. The ditch measured 0.68m wide and 0.14m deep. The two silty clay fills were devoid of finds. Two soilmarks were also plotted north-west of the ditch, and one, a possible pit (1606) was sectioned, but proved to be irregular and was probably natural.

4.7 Trenches 18 and 25-27 (Figs 10 and 12)

- 4.7.1 Trenches 18 and 25-27 were situated in the north-western part of Land Parcel 41 south of Trenches 8, 9 and 10.
- 4.7.2 Trench 18 was the northernmost of the group and contained a natural feature (1802).
- 4.7.3 Trench 25 was located to the south-west of Trench 18 and contained a possible posthole in the middle part of the trench. The feature (2500) was circular, and measured 0.34m wide and 0.1m deep. Its brown-grey sandy clay fill contained small flecks of charcoal but no finds.
- 4.7.4 Trench 26 was located to the east of Trench 25 and contained a N-S aligned ditch in the western part of the trench. Ditch 2603 measured 1.34m wide and 0.23m deep (Fig. 12 section 2600). Its single fill was a greyish-brown silty sand (2604) from which five sherds of Iron Age pottery was recovered. The ditch was on the same alignment and only slightly further east than ditch 805 in Trench 8 to the north, so ditch 2603 could be a continuation. It was also on a parallel alignment with cropmark ditches beyond the trench to the east, and might be one of a series of field boundary ditches.
- 4.7.5 Trench 27 was located to the east of Trench 26 and contained a ditch terminus at the northern edge of the trench. Ditch 2703 was aligned NE-SW and measured 0.52m in width and 0.19m in depth. It contained two grey-brown sandy clay fills, both devoid of finds.

4.8 Trenches 20, 22, 28 and 30 (Figs 11 and 12)

- 4.8.1 Trenches 20, 22 and 28-30 were located in the northern part of Land Parcel 41, east of Trench 27 and south of Trenches 11-13.
- 4.8.2 Trench 20 contained two probable tree-throw holes and Trench 22 contained a soilmark interpreted as a geological feature.
- 4.8.3 Trench 28 was the south-westernmost of the group and contained a single ditch in the western part of the trench. Ditch 2803 was aligned N-S and corresponds with the linear cropmark also identified as ditch 1103 in Trench 11 to the north. Ditch 2803 measured 0.96m wide and 0.31m deep and contained a single grey-brown silt-clay fill devoid of finds (Fig. 12 section 2800).
- 4.8.4 Trench 30 was located in the south-east of this group and revealed two NNW-SSE aligned parallel ditches, 3003 and 3005, in the western part of the trench. Both ditches corresponded with linear cropmarks. The western cropmark was also identified as ditch 1302 in Trench 13 to the north; the eastern cropmark did not reach Trench 13, but ditch 1304 there may be a continuation of ditch 3005. The western ditch (3003) measured 1.1m wide and 0.16m deep, and had a single fill of grey-brown silty-clay with occasional charcoal inclusions but no finds (Fig. 12 section 3000). Situated 6m to the east, ditch 3005 measured

0.68m wide and 0.14m deep and had an orange-grey silty clay fill, but this was devoid of finds (Fig. 12 section 3001).

4.9 Trenches 32, 34, 35, 47 and 49 (Figs 13 and 14)

- 4.9.1 Trenches 32, 35, 47 and 49 were located in the north-east corner of Land Parcel 41.
- 4.9.2 Trench 32 was located in the north-east corner of the group and revealed three pits. Pit 3202 is the most northern of the group, and it continued beyond the western edge of the trench. The pit measured 0.84m wide and 0.31m deep. It was filled with a sequence of three fills. The top fill (3208) contained fragments of glass bottles dated to the late 19th and early 20th centuries. Pit 3203 was in the centre of the trench and measured 1.29m wide and 0.20m deep with a single fill that contained no finds (Fig. 14 section 3201). The third pit, 3204, was farther south and measured 0.62m wide and 0.19m deep with a single undated fill.
- 4.9.3 Trench 34 revealed a single ditch (3402), aligned NW-SE. It was not excavated. It was 0.55m wide and was filled with a dark black-grey silty sand. This may represent a boundary ditch.
- 4.9.4 Trench 35 was located south-west of Trench 32 and contained two ditches. Ditch 3502 was aligned NE-SW and measured 0.81m wide and 0.17m deep (Fig. 14 section 3500). It had a single light greyish-brown clayey silt fill (3503) that contained late Bronze Age or early Iron Age pottery, including one possible Beaker sherd. Ditch 3505 was orientated NW-SE and measured 0.81m wide and 0.17m deep (Fig. 14 section 3501). It had a single undated fill.
- 4.9.5 Trench 47 was situated south of Trench 35 and revealed a ditch and a posthole near the centre of the trench. Ditch 4702 was aligned NNW-SSE and was not seen in any of the adjacent trenches. It measured 1.99m wide, but the base was not reached owing to space limitations within the trench. Its single fill (4703) contained animal bone, shelly pottery tentatively dated as medieval pottery of c 1000-1150 and brick or tile dated to the post-medieval period. The posthole (4704) was immediately west of the ditch and was circular in plan, it measured 0.26m wide and 0.10m deep. Its single fill contained no finds.
- 4.9.6 Trench 49 was situated to the east of Trench 47. It revealed a single ditch 4903 which measured 0.75m wide and 0.2m deep with a single fill (4904), from which environmental sample (sample 3) was recovered (Fig. 14 section 4900). This contained abraded sherds of later prehistoric pottery, and one sherd of shelly pottery tentatively assigned to the medieval period (11th-12th century), though this may alternatively have been Roman. Eleven sherds of Roman pottery were also recovered from the subsoil in this trench. The charred remains comprised a charred hazelnut shell and an indeterminate grain seed.
- 4.9.7 The alignment of the ditch closely corresponds with a mapped historic boundary that appears on the first edition OS map. It is uncertain if this feature was the mapped post-medieval field boundary because the ditch was recorded as being significantly deeper in Trenches 66, 84 and 101 to the south.

4.10 Trenches 72, 84, 85, 100 (Figs 15 and 16)

- 4.10.1 This group of trenches were located in the south-east corner of the field which constitutes the northern half of Land Parcel 41.
- 4.10.2 Trench 72 lay to the in the north-west of the group. It revealed three pits: 7202, 7204 and 7206. Feature 7202 was a shallow, ovoid pit measuring 0.6m wide and 0.12m deep (Fig. 16 section 7200; Plate 2). The single fill (7203) showed no evidence of burning in situ, but did have a deposit of charcoal at the base, overlain by reddened fill suggesting the dumping of material from a bonfire, hearth or oven. This pit contained late Bronze Age or early Iron Age pottery and a small amount of fired clay of possibly prehistoric date. A sample was taken for environmental remains, and produced a small charcoal flot (sample 1).
- 4.10.3 Pits 7204 and 7206 were similar in form to each other and contained single undated fills.
- 4.10.4 Trench 85 was located on the eastern side of Land Parcel 41. The trench contained one pit, a charcoal deposit and a natural feature. Pit 8504 was subcircular and measured 0.80m wide and 0.24m deep and had three undated fills (Fig. 16 section 8501). Layer 8502 was a shallow spread of charcoal, 0.54m wide and 0.06m deep. It had no clear cut but may represent the base of a truncated feature, or perhaps a burnt tree bole. No finds were recovered from the layer.
- 4.10.5 Trenches 66, 84 and 100 all revealed a post-medieval boundary ditch that appears on historical mapping (Figs 2 and 15). It measured up to 1.5m wide and more than 0.5m deep, although it was not bottomed in Trenches 84 and 100 (Fig. 16 section 8400; Plate 4).
- 4.10.6 In ditch 8402 its single fill, 8403, produced a fragment of post-medieval glass, post-medieval or modern pottery, ceramic building material (CBM), and fragments of 19th-century field drain. The ditch intervention in Trench 100 was heavily disturbed by a land drain. In Trench 66 the ditch was cut by a modern drain and was not investigated.

4.11 Trench 107 (Figs 17 and 18)

- 4.11.1 Trench 107 was located on a spur to the east of the main part of Land Parcel 41 and targeted a pair of linear cropmarks aligned NNW-SSE. The trench revealed five ditches, all on much the same NNW-SSE alignment, one probably recut.
- 4.11.2 Ditch 10702 was at the east end of the trench. It was 1.06m wide and 0.08m deep and had one fill which contained pottery and post-medieval brick and roof tile.
- 4.11.3 Ditch 10704 was to the west of 10702 and measured 2.08m wide and 0.69m deep (Fig. 18 section 10700; Plate 5). It had three fills. The upper fill of 10704 contained 19th-century peg tile and field drain fragments. This ditch corresponded to the eastern of two linear cropmark ditches, and is on the same alignment of a boundary on historic mapping.

- 4.11.4 Ditch 10712 matches the alignment of the western linear cropmark. It measured 1.15m wide and 0.49m deep, and had two fills, neither of which contained finds (Fig. 18 section 10703).
- 4.11.5 Farther west, 10708 measured 2.28m wide and 0.33m deep. The feature was cut by ditch 10710, which measured 0.96m wide and 0.33m deep and had a single fill that did not contain any finds.
- 4.11.6 At the western end of the trench was ditch 10715 which measured 2.60m wide and was 1.20m deep. The ditch had three fills but produced no dating evidence.

4.12 Trenches 68, 77, 86 (Figs 19 and 20)

- 4.12.1 This group of trenches were located at the western edge of Land Parcel 41.
- 4.12.2 Trench 68 revealed the remains of a possible kiln (Plate 1). As the feature extended beyond the edges of the excavation area, it was difficult to interpret the precise form of the structure and the original function is uncertain.
- 4.12.3 The observable remains were confined to the western end of the trench and appeared to be partially overlying the subsoil. Limited excavation work revealed a shallow cut or depression (6808), which measured up to 0.24m deep and at least 1.44m wide, although the edges of the cut were diffuse and overlain by later deposits. An apparent dump of bricks and reddish-brown silty clay (6802/6803) was within the cut. Although some of the bricks appeared to have been placed deliberately, the overall pattern was somewhat jumbled. The reddish-brown matrix within which they sat was presumably derived from a combination of degraded bricks and heat-affected soils. Although this was not necessarily evident as *in situ* burning, a sample was taken for environmental remains, and produced comminuted charcoal and possible wheat seeds (sample 2). Overlying the brick deposits (6802/6803) was a larger spread of dark grey, charcoal-rich material, 6806. This deposit sealed much of feature and covered an area approximately 6m long and presumably survived within the depression created by 6808.
- 4.12.4 The fragments of brick roof tile and floor tile from deposits 6802 and 6803 are all dated to between the 15th and 16th centuries. A 2g sherd of 19th-century whiteware was also recovered from deposit 6802, but on balance this would appear to be intrusive here.
- 4.12.5 Adjacent to 6808 was a posthole, 6804. It had steep sides and a concave base and measured 0.44m wide and 0.36m deep. It is possible that this formed part of a structure or shelter associated with the possible kiln.
- 4.12.6 Trench 77 was located south of Trench 68 and also revealed evidence for industrial activity within the vicinity. At the northern end of the trench was a large spread charcoal-rich material, 7704. It covered an area approximately 7m in length and survived to a thickness of 0.13m (Fig. 20 section 7700; Plate 3). This was directly overlying the subsoil, and a small ditch (7702). Both the fill of the ditch (7703) and layer 7704 contained large quantities of brick, identical to that in Trench 68 and also dated to the 15th to 16th centuries.
- 4.12.7 In the southern half of the trench, three features were distinguishable from the underlying subsoil as bands of mixed light-brown silt and clay deposits containing CBM fragments. These included ditches 7710, 7708 and layer 7707

(Fig. 20 section 7702). These are thought to represent the remains of shallow drainage features that were later backfilled using debris from the adjacent activities.

- 4.12.8 Trench 86 was located to the south-east of Trench 77 and revealed a single undated ditch 8603 sealed beneath the subsoil layer 8601. This was 1.2m wide and 0.36m deep with a single fill (Fig. 20 section 8600).

4.13 Trenches 51 and 104 (Fig. 2)

- 4.13.1 Trench 51 was located near the north-west corner of Land Parcel 41. At the eastern end of the trench was a small ditch, 5103. It was orientated NW-SE and was 0.34m wide and 0.2m deep. It contained a single undated fill.
- 4.13.2 Trench 104 was close to the modern hedge line that bisects Land Parcel 41. The trench contained one ditch aligned E-W. It measured 0.6m wide and 0.28m deep with a single fill which contained residual late Bronze Age or early Iron Age pottery, an iron nail and a post-medieval brick.

4.14 Trenches 112, 114, 116, 119, 135, 140, 141 and 149 (Figs 21 and 22)

- 4.14.1 This group of trenches was located to the south of Trenches 104 and 105, and south of the E-W-aligned field boundary that bisects Land Parcel 41, and divides Havering in Greater London (to the north) from the borough of Thurrock within the County of Essex (to the south).
- 4.14.2 Trenches 112 and 141 were located towards the east of the site. Both trenches revealed a post-medieval field boundary that aligned NNW-SSE. In Trench 112, ditch 11202 produced fragments of 15th-16th-century brick. In Trench 141, the ditch (14102) was 1.04m wide and 0.42m deep with two fills, neither of which contained finds (Fig. 22 section 14100).
- 4.14.3 Trench 114 was on the western side of Land Parcel 41. It revealed a single sub-ovoid pit (11402) at the centre of the trench, which was 0.51m wide and 0.15m deep. The single fill contained no finds.
- 4.14.4 Trench 116 was positioned to the east of Trench 114 and contained a furrow-like feature and a pit. The possible furrow, 11602, was 1.70m wide and 0.10m deep with a single undated fill. The possible furrow was aligned NE-SW and is the only feature of this type to be recorded on the site. Perhaps indicating that others have been truncated by modern agriculture, given the shallow depth of overburden on site. Feature 11602 cut a pit (11604) which measured 0.80m wide and 0.28m deep. The feature had a single fill, which contained no finds.
- 4.14.5 Trench 119 was situated to the east of Trench 116. Ditch 11904 was revealed at the northern end of the trench. It was aligned NNE-SSW and measured 0.7m wide and 0.2m with a single undated fill. A Neolithic flint blade was recovered from the subsoil (11903). At the southern end of the trench was a modern drainage ditch, 11902.
- 4.14.6 Trench 135 to the south of Trench 116. The trench contained two pits at its eastern end. Pit 13503 was subcircular in plan and measured 0.5m wide and 0.45m deep (Fig. 22 section 13500; Plate 6). It had three fills, including a dump of charcoal-rich material (13505). The adjacent pit (13507) was ovoid in plan

and was cut by a modern land drain. The pit had three fills, including a dump of charcoal (13508). Both 13505 and 13508 were sampled (samples 3 and 4 respectively), and the samples contained a high proportion of charcoal and burnt flints, but no further information about the date of these features.

- 4.14.7 Trenches 140 and 149 were situated to the east of Trench 135 and both targeted a NE-SW aligned cropmark. Ditch 14902 in Trench 149 probably represents the cropmark, although offset around 6m to the south-east, as was ditch 14004 in Trench 140, with which ditch 14902 was in line. Ditch 14902 measured 0.82m wide and 0.40m deep and was subsequently recut by ditch 14905 on the same alignment (Fig. 22 section 14900; Plate 7). Ditch 14905 was 1.36m wide and 0.36m deep. A fragment of fired clay was recovered from ditch 14902 and a sherd of early Iron Age pottery was recovered from the fill of 14905.
- 4.14.8 At the northern end of Trench 140 was a small undated pit, 14002. It measured 0.42m wide and 0.10m deep.
- 4.14.9 Feature 14907 was one of the many drainage ditches observed in this parcel with a distinctly mixed orange-and-grey fill.

4.15 Trenches 156-160 (Figs 23 and 24)

- 4.15.1 This group of trenches was located in the south-west part of Land Parcel 41, south of Trenches 145-148 and south-west of Trench 149.
- 4.15.2 Trench 156 was the westernmost trench, adjacent to the site boundary, and contained two ditches. Ditch 15603 was aligned NE-SW and may be the same feature as one of the ditches in Trench 157 to the east, most probably ditch 15708. Ditch 15603 measured 1.61m wide and 0.27m deep and contained a single dark grey-brown clay-silt fill (Fig. 24 section 15600). There were no finds. To the south, an E-W aligned ditch (15605) measured 1.12m wide and had a dark brownish-grey clay-silt fill, but was not excavated.
- 4.15.3 Trench 157 was located to the east of Trench 156 and contained four ditches. Ditch 15708 extended across the western part of the trench on an ENE-WSW alignment. It measured 1.64m wide and 0.31m deep (Fig. 24 section 15702). Its single fill was a dark brownish-grey sandy silt (15709) from which one sherd of late Bronze Age to middle Iron Age pottery and a struck flint flake were recovered. Ditch 15706 was located to the south, on the same alignment, and measured 0.41m wide and 0.11m deep (Fig. 24 section 15701). It had a single dark brownish-grey sandy-silt fill (15707) that contained one sherd of pottery of late Bronze Age to middle Iron Age date. Ditch 15703 was situated immediately to the south of ditch 15706 on broadly the same alignment, and also appeared slightly irregular in plan. It was 0.52m wide and 0.13m deep (Fig. 24 section 15700) and contained a sherd of pottery of middle Bronze Age to middle Iron Age date in its single brownish-grey sandy silt fill (15704). A modern ditch (15705) truncated the three other ditches on a WNW-ESE alignment.
- 4.15.4 Trench 158 was situated to the east of Trench 157 and contained three ditches and a natural feature. Ditches 15805 and 15806 were located in the northern part of the trench; both ran on an ENE-WSW alignment, 15805 south of 15806, and these are likely to be continuations of ditches in Trench 157, probably

15706 and 15703. Ditch 15805 was not excavated, but 15806 was, and measured 0.73m wide and 0.21m deep (Fig. 24 section 15800). The single light brownish-grey sandy-silt fill (15808) contained one sherd of pottery of middle Bronze Age to middle Iron Age date. It was 0.6m wide and contained a light brownish-grey sandy silt fill. A natural feature (15807) was located in the central area of the trench. In the southern part of the trench, ditch 15803 was aligned NE-SW and measured 2.64m wide and 0.32m deep and had a single fill of grey-brown silt devoid of finds.

- 4.15.5 Trench 159 was located to the east of Trench 158 and contained a single ditch. Ditch 15903 was aligned NNW-SSE, was 0.47m wide and 0.11m deep, and contained a grey-brown sandy silt fill devoid of finds.
- 4.15.6 Trench 160 was situated to the east of Trench 159. It contained a single ditch in the northern part of the trench. Ditch 16003 was aligned ENE-WSW and measured 1.62m wide and 0.3m deep. It contained a single brownish-grey clay-silt fill devoid of finds.
- 4.15.7 The series of ditches on a WSW-ENE alignment running through Trenches 156-158 are in line with cropmark ditches some 200m to the west (see Fig. 3), and despite the distance between them, it is possible that they represent a continuation of these cropmarks.

4.16 Trench 163 (Figs 25 and 26)

- 4.16.1 Trench 163 was located in the south-western part of Land Parcel 41, east of Trenches 160-162, and adjacent to the border with Land Parcel 42. The trench was located to investigate the cropmark of a circular ring ditch and the semi-circular cropmark of a much larger enclosure to the north-west.
- 4.16.2 Ditch 16303 was revealed at the north-west end of the trench, aligned ENE-WSW. It lay 1m south-east of the semicircular cropmark but probably corresponds to it. The ditch measured 0.97m wide and 0.22m deep, and had a single fill of dark greyish brown sandy silt that contained a flint flake (Fig. 26 section 16300). To the south-east of ditch 16303 and on a similar alignment, ditch 16305 measured 1.27m wide and was very shallow, at 0.08m deep. Its single fill was a dark brownish grey sandy silt that was devoid of finds.
- 4.16.3 At the south-east end of the trench, ditch 16307 corresponded to the ring ditch cropmark. The ditch measured 1.55m wide and 0.24m deep (Fig. 26 section 16302) and was filled with a brownish grey sandy silt, but there were no finds.

4.17 Trenches 164, 167 and 172-173 (Figs 27 and 28)

- 4.17.1 This group of trenches was located in the south-western part of Land Parcel 41, south of Trenches 156-160.
- 4.17.2 Trench 164 revealed a possible posthole and a natural feature; the north-west end of the trench was blank. Posthole 16403 was sub-circular in shape and measured 0.26m in width and 0.08m in depth. Its single greyish-brown silt-clay fill was devoid of finds.
- 4.17.3 Trench 166 contained a large soilmark whose edge was tested, and which was judged to be a natural feature.
- 4.17.4 Trench 167 revealed two postholes in the southern part of the trench. Both were circular, and were situated 2m apart. The northern posthole was 16703,

which measured 0.2m wide and 0.17m deep. Posthole 16075 to the south measured 0.26m wide and 0.09m deep. Both contained blackish-grey silt fills devoid of finds, but samples were taken for environmental remains (samples 5 and 6 respectively). The flots were dominated by charcoal including hazel and oak and also seeds of field gromwell.

- 4.17.5 Trench 172 was located to the south-west of Trench 167. It revealed an E-W aligned ditch and a pit. Ditch 17203 measured 1.17m wide and 0.42m deep (Fig. 28 section 17200). Its single dark grey-brown sandy-silt fill did not contain finds. Pit 17205 was partially revealed, measuring 0.7m wide and 0.38m deep and containing a dark grey-brown sandy-silt fill devoid of finds (Fig. 28 section 17201).
- 4.17.6 Trench 173 revealed two NW-SE aligned ditches in the western part of the trench. Ditch 17305 was only partially revealed at the western end of the trench, extending beyond the trench limit. The visible part measured 1.54m wide and 0.36m deep (Fig. 28 section 17301). Its yellow-brown sandy-clay fill (17306) contained three sherds of Roman pottery. Ditch 17303 was situated 5.5m to the east of ditch 17305 and appeared to be aligned parallel with it. This ditch measured 1.56m wide and 0.3m deep, but did not produce any finds. Given its similar size and orientation to 17303, it is possible that 17305 was also Roman, and that the two ditches defined a trackway. No continuation of either ditch was, however, seen in Trench 166 to the north.

4.18 Trenches 168-170, 174-177 (Figs 29 and 31)

- 4.18.1 This group of trenches was situated in the south-west of Land Parcel 41, east of Trenches 167 and 173, south of Trenches 161 and 163, and west of the boundary with Land Parcel 42.
- 4.18.2 Trench 168 revealed a possible pit in the central area of the trench. Pit 16803 was oval, measured 1.09m long and 0.7m wide, and was 0.11m deep. No finds were recovered from its single brownish-grey silty clay fill (16804), but a sample was taken for environmental remains and produced charred wheat, possibly including sprouted grain, and a mixture of weed seeds (sample 7). Some oak and hazel charcoal was also identified.
- 4.18.3 Trench 169 was situated to the east of Trench 168 and contained a single pit in the central part of the trench. Only the west part of pit 16903 lay within the trench, and this measured 0.69m wide and 0.42m deep. The earliest fill was a light yellow-grey clayey sand 0.1m deep and was devoid of finds. The upper fill was a grey-brown sandy silt 0.32m deep and was also not dated.
- 4.18.4 Trench 170 was situated to the east of Trench 169 and revealed a single ditch. Ditch 17003 was aligned N-S and measured 0.53m wide and 0.21m deep. No finds were recovered from its single light reddish brown sandy silt fill.
- 4.18.5 Trench 174 was situated in the south-west of the group and contained a natural feature (17403) in the central part of the trench.
- 4.18.6 Trench 175 was situated to the east of Trench 174 and revealed a natural feature at the eastern end of the trench.
- 4.18.7 Trench 176 was situated to the east of Trench 175 and revealed a recut ditch and two pits. Ditch 17605 ran E-W across the centre of the trench, and cut an earlier soilmark numbered 17612, which was a whitish-yellow sandy clay

variation in the natural. Ditch 17605 measured 0.43m wide and 0.24m deep with a V-profile, and was filled by a single, yellowish-brown sandy clay fill that was devoid of finds (Fig. 31 section 17600). This ditch was recut on its western side by ditch 17603, which was also V-profiled, and which measured 0.38m wide and 0.17m deep. Its single yellow-brown sand-clay fill was also without finds. No trace of these ditches appeared in Trench 177 to the east or Trench 175 to the west, although both were in line.

- 4.18.8 To the south of the ditches, pit 17607 lay mostly within the trench and appeared to be circular, measuring 0.78m in diameter. It proved to be 0.15m deep with one reddish brown sandy clay fill that was devoid of finds. The eastern edge of pit 17609 lay within the southern part of the trench, and the visible part was 0.81m wide. This pit was 0.14m deep, again with a reddish brown sandy clay fill but no finds.
- 4.18.9 Trench 177 was situated south-east of Trench 170 and east of Trench 175. It contained a natural feature (17711) in the central part of the trench and four shallow ditches on the same N-S alignment in the eastern part of the trench, none of which contained any finds. Ditch 17703 was at the eastern end of the trench and measured 0.38m wide and 0.17m deep, with a light yellow-brown sandy clay fill. Ditch 17705 lay 4m west of ditch 17703 and measured 0.56m wide and 0.17m deep with a greyish-brown sandy silt fill. Ditch 17707 was a some 5m west of ditch 17705, measured 0.52m wide and 0.15m deep, and also had a greyish-brown sandy silt fill. The westernmost ditch, 17709, lay only 2m further west, and measured 0.87m wide and 0.14m deep. This had a single brownish-grey sandy silt fill (17710) from which an amorphous piece of metal was recovered.

4.19 Trenches 178-180 and 184-185 (Figs 30 and 31)

- 4.19.1 This group of trenches was located in the south-western corner of Land Parcel 41, south of Trenches 171-173.
- 4.19.2 Trench 178 was in the north-west of the group and revealed a natural feature (17803).
- 4.19.3 Trench 179 was situated to the east of Trench 178 and revealed a possible waterhole. It was rounded in plan and measured 8.5m wide and 0.49m deep, with a single fill of greyish-brown silty sand (Fig. 31 section 17900). No finds were recovered from it.
- 4.19.4 Trench 180 was located to the east of Trench 179. It contained one ditch and two pits in the central part of the trench. Ditch 18003 was aligned N-S and measured 2.75m wide and 0.61m deep. It contained three sandy silt fills, none of which contained finds. The two pits were located to the east of the ditch. Pit 18007 was circular and measured 1.06m wide and 0.49m deep. Its single grey-brown sandy silt fill (18008) contained a single fill of pottery of middle Bronze Age to middle Iron Age date. Pit 18009 to its east lay partly outside the southern edge of the trench, the part within the trench measuring 0.6m wide and 0.49m deep. Its two sandy silt fills were devoid of finds.
- 4.19.5 Trench 184 south of Trench 178 revealed a ditch and a pit. Ditch 18405 was aligned roughly E-W in the southern part of the trench. It was not excavated, but its fill was recorded as a brownish-grey silty sand. The ditch was 0.47m

wide. To the south of the ditch was a pit (18403), only the western part of which lay within the trench. The pit measured 1.92m wide and 0.35m deep and contained a single grey-brown silty-sand fill devoid of finds.

- 4.19.6 Trench 185 was situated to the east of Trench 184. It contained a single ENE-WSW aligned ditch (18503), which measured 1.1m wide and 0.23m deep. It had a single grey-brown silt-sand fill that did not contain finds. The projected line of this ditch was very close to ditch 18405 to the west, and although the ditch in Trench 184 was narrower, it is possible that both were parts of the same linear boundary. No trace of ditch 18503 was evident in Trench 186 further east.

4.20 Trenches 187, 189 and 190 (Fig. 32)

- 4.20.1 This group of trenches was situated in the south-east corner of Land Parcel 41, east of Trench 186 and south of Trenches 174-177 and blank Trenches 181-183.
- 4.20.2 Trench 187 revealed a ditch in the eastern part of the trench. Ditch 18703 was aligned roughly N-S and measured 0.64m wide and 0.18m deep. Its single grey-brown sandy-silt fill (18704) contained a single sherd of pottery of broad Roman date.
- 4.20.3 Trench 189 was situated in the east of the group and contained a single pit. Pit 18903 was circular in shape and measured 0.61m in diameter and 0.14m deep. There were no finds recovered from its single yellowish-grey silty clay fill.
- 4.20.4 Trench 190 lay south-west of Trench 187, and contained a ditch and a natural feature. Ditch 19003 ran NNW-SSE across the west part of the trench, and was 1.17m wide and 0.46m deep, with three fills, a greyish-brown silty sand, an eroded natural reddish-brown sand and a light grey silty sand, none of which contained finds. The projected line of this ditch matched the position of ditch 18003, which also contained three sandy silt fills, and these are probably parts of one linear boundary ditch.

4.21 Trenches 191, 198, 204-206, 208 and 214 (Figs 33 and 34)

- 4.21.1 This group of trenches were all located within Land Parcel 42.
- 4.21.2 Trench 191 was situated in the north-west corner of the field and revealed one NE-SW aligned ditch (19103) that measured 1m wide and 0.2m deep (Fig. 34 section 19100). The single fill contained no finds.
- 4.21.3 Trench 198 was south-east of Trench 191 and contained one ditch terminus (19803) which was orientated. It measured 0.40m wide and 0.1m deep. The terminus had one fill which contained no finds.
- 4.21.4 Trench 204 recorded natural features and one of these (20403) was aligned with features recorded as a ditch in Trenches 208 (20807) and 214 (21403) to the south and is likely to be a continuation of this ditch. It measured 0.4m wide and 0.14m deep and its single fill was a mid brownish-orange sandy clay.

- 4.21.5 Trench 205 was immediately south-east of Trench 198 and contained a pit and two natural features. The pit (20503) was sub-rectangular in plan and measured 0.3m wide and 0.06m deep. It had a single undated fill, 20504.
- 4.21.6 Trench 206 was immediately east of Trench 205 and contained a large NNW-SSE aligned ditch, 20604. It measured 1.52m wide and 0.53m deep. The ditch had two fills and contained no finds (Fig. 34 section 20600; Plate 8).
- 4.21.7 Trenches 208 and 214 were to the south-west of Trench 205. Trench 208 contained a curvilinear ditch (20803), a NNW-SSE-aligned ditch (20807) and a posthole (20805) (Plate 16). Ditch 20803 measured 0.6m wide and 0.14m deep with sides that extended beyond the northern edge of the trench. It was filled with a single sterile fill (Fig. 34 section 20800).
- 4.21.8 Posthole 20805 was to the east of both ditches. It measured 0.2m wide and 0.1m deep, the single fill contained no finds.
- 4.21.9 Ditch 20807 corresponded to a linear cropmark on a NNW-SSE alignment. It was only excavated to a depth of 0.44m deep due to the discovery of a modern pipe at the base of the feature. The backfill contained a single fill that produced fragments of brick dating to the 15th-16th centuries. The cropmark was also crossed by Trench 214 to the south, and here corresponded to ditch 21403, which was just over 1.6m wide and was 0.42m deep (Fig. 34 section 21400). Ditch 21403 had a single fill that was probably deliberate backfill, as it contained post-medieval roof tiles, pottery dated to c 1720-1780 and part of a wine bottle. Based on the finds recovered from the excavations this may have been a post-medieval drainage ditch.

4.22 Trenches 224, 227-232, 235 and 238 (Figs 35 and 36)

- 4.22.1 This group of trenches were located in the western half of Land Parcel 60, west of the B186.
- 4.22.2 Trench 224 was situated in the north-east corner of the group and revealed three ditches, all on a NW-SE alignment. Ditch 22403 had two fills (Fig. 36 section 22400; Plate 9), which contained a mixture of finds, among them a 19th-century clay pipe, pottery dated to c 1830-1900, part of a wine bottle, decorative glass of late 19th/early 20th-century date, and some iron objects of the same date.
- 4.22.3 Ditch 22406 measured 0.34m wide and 0.16m deep. Its single fill contained no finds and was cut by later ditch, 22408 (Fig. 36 section 22401). This later feature measured 0.60m wide and 0.20m deep and had one fill which contained no finds.
- 4.22.4 None of the features in this trench have any cropmarks associated with them, but they are aligned with a field boundary that is mapped to the south and are perhaps an earlier continuation of this boundary.
- 4.22.5 Trenches 229 and 230 were located to the south-west of Trench 224. They both revealed what appeared to be the same WNW-ESE aligned ditch, 22903 and 23003. Ditch 22903 measured 0.35m wide and 0.09m deep. It contained a sterile deposit, 22904. Ditch 23003 was recorded in plan only and not excavated.
- 4.22.6 Trench 231 was immediately east of Trench 230 and contained one N-S-aligned ditch. The base of ditch 23103 was not reached. Although its two fills

yielded no artefacts, it was recorded on the same location and orientation as a 19th-century field boundary recorded on historic mapping.

- 4.22.7 Trenches 227, 228 and 232 were all located in shallow dips in the topography and correspondingly each revealed a deeper sequence of deposits than elsewhere. Due to a restriction on the depth of excavation, to prevent damaging land drains, the deeper deposits in these trenches could not be removed. Consequently, slightly gleyed, deposits were left at the base of each trench covering the natural geology. The origins of these depressions are unclear; they may be the remnants of ponds, or perhaps became ponds following quarrying activities. They could be the ploughed remains of bomb craters.
- 4.22.8 Trench 235 was positioned immediately south of Trench 228. Pits 23503, 23505 and 23509 were clustered towards the western end of the trench, close to a small ditch terminus (23507). Pit 23503 was sub-ovoid in plan and measured 0.31m wide and 0.07m deep. Its single fill contained no finds.
- 4.22.9 Pit 23505 truncated the end of ditch terminus 23507. It was irregular in plan and it measured 0.18m wide and 0.16m deep. The single fill contained occasional charcoal flecks but no finds. The most easterly pit, 23509, was ovoid in plan and measured 0.31 wide and 0.08m deep. The single fill contained no finds.
- 4.22.10 Ditch terminus 23507 measured 0.4m wide and 0.17m deep with moderately sloping sides and a flat base. The single fill contained no finds.
- 4.22.11 At the eastern end of the trench were ditches 23513 and 23515. Ditch 23513 was 0.72m wide and 0.26m deep and had been cut by 23515 (Fig. 36 section 23503). The single fill contained a small quantity of Roman pottery. Ditch 23515 measured 1.64m wide, but the base was not reached due to its depth. It contained fragments of post-medieval CBM.
- 4.22.12 Trench 238 was immediately south of Trench 231 and contained a N-S-aligned ditch. The ditch was disturbed by a tree-throw hole (23806) at the northern end of the trench. Ditch 23803 measured 0.4m wide and 0.16m deep. It contained a clay pipe dating from 1850-1900, a copper-alloy nail and an iron nail of 19th- or 20th-century date, and CBM dating between the 15th and 18th centuries.

4.23 Trenches 240, 246, 247, 251 and 254 (Figs 37 and 38)

- 4.23.1 This group of trenches was located at the western end of Land Parcel 60 and on the south side.
- 4.23.2 Trench 240 was in the north-west corner of the group. The trench contained four pits and a natural feature. At the eastern end of the trench, pit 24003 measured 0.76m wide and 0.15m deep, with a single undated fill containing flecks of charcoal (Fig. 38 section 24000; Plate 10).
- 4.23.3 Pits 24005, 24007 and 24009 were similar in appearance to 24003 and also contained single, undated fills. A sample was taken from deposit 24006, from pit 24005, for charred plant remains but only produced charcoal fragments (sample 1).
- 4.23.4 Trench 246 was immediately south of Trench 240. At the northern end of the trench was pit 24603 (Plate 11). Its single fill (24604) contained fired clay of

indeterminate date, and a considerable amount of charcoal, from which sample 2 was taken, though the flint did not produce charred grain or weed seeds.

- 4.23.5 Ditch 24606 was recorded on a NE-SW alignment at the southern end of the trench. This was 1.08m wide and 0.38m deep, and had steep, almost vertical sides and a wide flat base (Fig. 38 section 24601). It contained a single fill that was without finds.
- 4.23.6 Trench 247 lay to the east of Trench 246 and contained a NE-SW-aligned ditch. This ditch was broadly aligned with ditch 24606, although it was notably smaller and appears to have curved towards a different alignment as it extended beyond the southern edge of the trench. Ditch 24703 measured 0.45m wide and 0.22m deep with a single undated fill.
- 4.23.7 Trench 251 was located at the eastern edge of this group. Ditch 25103 was N-S aligned and measured 0.79m wide and more than 0.52m deep. It had three fills yielding a sherd of post-medieval pottery dating from 1850-1950. The ditch is probably the continuation of 23103 to the north and as it also matches a mapped historic boundary.
- 4.23.8 East of 25103 was ditch terminus 25107 which was aligned NE-SW. The terminus was 0.47m wide and 0.24m deep and the single fill contained no finds.
- 4.23.9 Trench 254 was south-east of Trench 247 and exposed three N-S-aligned ditches. Ditch 25403 was at the centre of the trench and was 1.06m wide and 0.40m deep, with an unusual profile, undercut on one side and stepped on the other, and a single fill without finds (Fig. 38 section 25400; Plate 12).
- 4.23.10 Ditch 25405 was 0.68m wide and 0.49m deep, and was U-profiled, with very steep sides and a flat bottom (Fig. 38 section 25401). Its single fill contained late Iron Age/ Roman pottery.
- 4.23.11 Ditch 25407 was 1.51m wide but its full depth was not reached (Fig. 38 section 25402). The single fill contained brick from the mid-15th to 16th centuries.
- 4.23.12 None of these ditches were seen in Trenches 242, 247 or 248 to the north, and their extent and functions is not clear.

4.24 Trenches 262, 265, 267, 271, 272 and 275-277 (Figs 39 and 40)

- 4.24.1 This group of trenches was located in the north-east corner of Land Parcel 60, adjacent to the B186 road between North and South Ockenden.
- 4.24.2 Trenches 262, 267 and 272 were located in the east of the group.
- 4.24.3 Trench 262 revealed two ditches, which were orientated N-S. Ditches 26203 and 26205 both had steep sides and a flat base and had single sterile fills (Fig. 40 section 26200). Ditch 26203 appears to continue to the south through Trenches 267 and 272 where it was recorded as ditches 26709 and 27203 (Fig. 40 section 27200). No dating evidence was recovered from this feature at any point along its length.
- 4.24.4 Trench 267 was immediately south of Trench 262 and in addition to ditch 26709, it revealed two postholes. Feature 26703 was circular, 0.22m wide and 0.20m deep with steeply sloping sides and a flat base (Fig. 40 section 26700).

Posthole 26706 was south of 26703 and was sub-circular measuring 0.30m wide and 0.22m deep (Fig. 40 section 26701; Plate 13). Neither of the postholes contained any finds.

- 4.24.5 Trench 265 was to the west of Trench 267 and revealed a single undated ditch on a NNW-SSE alignment, 26503. It measured 0.69m wide and 0.24m deep with a single fill. A possible continuation of this ditch was seen in Trench 275 to the south, and was numbered 27503.
- 4.24.6 Trench 271 was to the west of Trench 272 and contained two parallel ditches which ran ENE-WSW at the eastern end of the trench. The ditches touched but did not intersect. Ditch 27103 was 0.95m wide and 0.24 deep.
- 4.24.7 Ditch 27105 was located on the northern side of 27103 and terminated at the ENE end within the trench. It measured 0.60m wide and 0.13 deep and had a single fill which produced a sherd of Roman pottery. No trace of either ditch was seen in Trench 272 to the east or Trench 274 to the south-west, indicating that the ditches had ended or turned before this.
- 4.24.8 Trench 275 revealed a single undated ditch 27503, aligned N-S. It measured 0.66m wide and 0.12m deep, and its projected line matches the position of ditch 26503 in Trench 265 to the north. No continuation of this ditch was seen in Trench 278 to the south.
- 4.24.9 Trench 276 was situated immediately east of Trench 275 and contained three curving ditches, the southern two possibly belonging to a single enclosure, with the third further to the north-east. Ditch 27607 measured 0.37m wide and 0.16m deep, and had a single fill (Fig. 40 section 27601; Plate 14). Ditch 27609 measured 0.47m wide and 0.11m deep. No finds were recovered from either section of the ditch. Assuming these segments of curvilinear ditch belonged to the same enclosure, they would suggest an enclosure some 10m across.
- 4.24.10 Ditch 27603 measured 0.34m wide and 0.14m deep with moderately sloping sides and a flat base (Fig. 40 section 27600). It also had a curvilinear shape in plan and could be the truncated remnants of a second enclosure ditch. The single fill contained no finds. At the west end this was disturbed by a shallow tree-throw hole with burning, which was numbered 27605.
- 4.24.11 Trench 277 was immediately east of Trench 276 and revealed the edge of a large boundary ditch (27703) on an ENE-WSW alignment. The full width of the feature was not exposed within the trench, but it measured in excess of 0.46m deep and was at least 0.78m wide. The single fill contained a sherd of early to middle Roman pottery. It was not observed in Trench 276 to the west, but could have returned northwards as ditch 27203 to the east.

4.25 Trenches 284, 285 and 289-292 (Figs 41, 40 and 42)

- 4.25.1 This group of trenches were located in the south-east corner of Land Parcel 60 west of the B186, south of Trenches 275-278, and the trenches were mostly targeted on a small cluster of cropmark features, some of the few to be recorded in this parcel (Fig. 4).
- 4.25.2 Trench 284 was targeted on a curvilinear cropmark and a discrete cropmark. Although no archaeological features corresponding to either cropmark was revealed, the trench did expose a small ditch (28403) at its north-west end.

The ditch was aligned N-S, measured 0.65m wide and was 0.10m deep. Its single fill produced a small sherd of Roman pottery.

- 4.25.3 Trench 285 was immediately east of Trench 284 and contained a single ditch at the southern end of the trench, which corresponded with a cropmark ring ditch. The ditch (28503) measured 0.70m wide and 0.16m deep (Fig. 40 section 28500; Plate 15) and had a light greyish-brown sandy silt fill, which did not produce any dating evidence.
- 4.25.4 Trench 287 targeted two further discrete cropmarks of the group scattered to the south and east of the ring ditch in Trench 285, but no archaeological features relating to either were found.
- 4.25.5 Trench 289 was approximately 60m to the south-east of Trench 285 revealed one N-S aligned ditch (28903) which measured 1m wide and 0.20m deep (Fig. 42 section 28900). The single fill contained no finds.
- 4.25.6 Trench 290 was situated immediately south of Trench 289 and revealed two NE-SW running ditches and a pit. Pit 29003 lies near the centre of the trench and contained a single fill without dating evidence.
- 4.25.7 Ditch 29007 was 0.4m wide and 0.12m deep (Fig. 42 section 29002). The single fill contained no finds.
- 4.25.8 At the southern end of the trench was a large ditch (29005) which measured 1.91m wide and 0.52m deep with a single fill (Fig. 42 section 29001). The fill contained medieval pottery and a piece of worked flint.
- 4.25.9 Trench 291 was immediately south of Trench 290 and revealed two ditches. Ditch 29103 was aligned N-S at the south-west end of the trench and measured 1.13m wide and 0.34m deep with one sterile fill (Fig. 42 section 29103).
- 4.25.10 At the centre of the trench, ditch 29105 was orientated NW-SE and measured 1.08m wide and 0.14m deep (Fig. 42 section 29101). It contained two fills, the primary fill containing medieval pottery dating to c 1100-1350 and animal bone.
- 4.25.11 Trench 292 was situated in the south-east corner of the site. It revealed a ditch and two pits. Ditch 29203 was at the south-western end, aligned N-S and the pits lay just south-west of the centre of the trench. The ditch was 0.66m wide and 0.18m deep.
- 4.25.12 Pit 29205 continued beyond the southern baulk of the trench and was truncated by 29207 on its western edge. It measured 0.80m wide and 0.23m deep. Pit 29207 was 1.68m wide and 0.22m deep. Both pits were filled by a single deposit and neither produced any finds.

4.26 Trenches 293-295, 296-298 and 302-304 (Figs 44 and 45)

- 4.26.1 This group of trenches was located in the north-east corner of Land Parcel 60, to the south and east of a curvilinear cropmark enclosure. Most of the area of the cropmark was inaccessible due to services, but was targeted by Trench 293 (Fig. 5).
- 4.26.2 Trench 294 was situated in the north-east of the group and following the removal of subsoil (29402), which contained early Roman pottery, revealed

two ditches. Pit 29405 was located in the central part of the trench. It measured 4.4m wide and was exposed to a depth of 0.54m, but was not bottomed. Two sandy clay fills were exposed, the earlier (29407) containing charcoal inclusions, cattle teeth and pottery of either Iron Age or Saxon date, together with a ridge tile probably of late medieval or early post-medieval date. An environmental sample from this fill produced mostly charcoal and a single wheat grain (sample 9). The upper fill (29406) contained 6 sherds of pottery tentatively dated as early Saxon and animal bones.

- 4.26.3 At the eastern end of the trench, narrow ditch 29403 was on the same alignment as ditch 29405. It measured 0.47m wide and 0.18m deep, and contained a single light greyish-brown silty clay fill devoid of finds.
- 4.26.4 Trenches 293 and 295. Trench 293 was situated to cross both of the southern terminals of the cropmark, but failed to locate either. A shorter trench (Trench 295) was therefore positioned a little further north to cross the south-western arm of the cropmark, and revealed a natural feature (29503) and two ditches. The ditches were slightly offset to the south-west of the mapped cropmark, but may nevertheless correspond to the cropmark enclosure. Ditch 29504 (Fig. 45 section 29501) was aligned NW-SE and measured at least 2.26m wide and 0.3m deep and contained a single fill of reddish-brown sandy silt. There were no finds. It was cut by another ditch on its western side (29506) which appeared to terminate within the trench. This ditch measured 1.3m wide and 0.08m deep and contained two sandy silt fills, but again no finds were seen.
- 4.26.5 Trench 296 was situated to the south-east of Trench 295 and contained a single ditch. Ditch 29602 was aligned ENE-WSW and measured 1.8m wide and 0.46m deep. It contained two fills. The lower was a grey-blue sandy clay, and the blueish hue suggests formation in standing water. The upper fill was a brown-grey clayey silt. No finds were recovered from either fill. The projected line of this ditch matches ditch 29703 in Trench 297 to the east, which may therefore have been a continuation.
- 4.26.6 Trench 297 revealed a single ditch. Ditch 29703 was aligned WSW-ENE but was slightly curving towards W-E as it ran east. It measured 0.71m wide and 0.17m deep, and was filled with reddish grey silty clay that was devoid of finds.
- 4.26.7 Trench 298 lay east of Trench 297 and was orientated N-S. It revealed two ditches and two pits. Ditch 29803 was located in the northern part of the trench, and appeared to represent a right-angled corner, running first W-E and then N-S, although the outside of the corner did not lie within the trench. The northern (E-W) side measured 1.45m wide and 0.37m deep. It had a dark grey-brown clayey silt lower fill from which two sherds of pottery of late Saxon to early medieval date was recovered. The upper fill was a lighter clay silt fill which did not contain finds. This ditch may represent part of an enclosure, and although the projected western continuation of the northern arm lies slightly south of ditch 29703, it is possible that the two were related.
- 4.26.8 Another ditch (29808) was aligned NW-SE in the middle part of the trench. It was 1m wide and 0.4m deep. A single sherd of pottery dated to the LIA-ER period was recovered from the brownish-grey clayey silt fill (29809).
- 4.26.9 Two pits were located just 'inside' the enclosure ditch. They were adjacent to each other and there was no stratigraphic relationship between them or with

ditch 29812 surviving (Fig. 45 section 29802). Pit 29810 was sub-circular in shape and measured 1.45m wide and 0.37m deep. Its single brownish grey clayey silt fill (29811) contained a single sherd of pottery of late Bronze Age to middle Iron Age date. The other pit (29814) measured 0.8m wide and 0.08m deep and its single clayey silt fill was devoid of finds. Another possible feature (29816) was not excavated.

4.26.10 Trench 302 lay south of Trench 296, and contained a single small pit. Pit 30203 was 0.3m in diameter and 0.12m deep, with a single grey sandy clay fill that did not contain finds. A natural feature numbered 30205 was also seen in this trench, and another natural feature in Trench 303.

4.26.11 Trench 304, which lay east of Trench 303 and south of Trench 298, contained a single posthole near to the western end of the trench. Posthole 30403 was circular, 0.5m in diameter but only 0.08m deep, with a single fill of dark brown sandy silt and charcoal flecks. An environmental sample was taken from this fill (sample 12).

4.27 Trenches 299, 307, 313, 314, 320 and 321 (Fig. 47)

4.27.1 This group of trenches was situated in the north-west of Land Parcel 60, south-west of the cropmark enclosure and Trenches 295 and 296 (Fig. 5).

4.27.2 Trench 299 revealed one natural feature (30603).

4.27.3 Trench 307 was situated to the south-east of Trenches 299 and 306. It revealed a ditch and a posthole. Ditch 30702 was aligned NNW-SSE and measured 0.96m wide and 0.48m deep. This may be the same ditch as that in Trench 313 to the south. The single grey-brown sandy-silt fill was devoid of finds. To the west of the ditch was a single posthole, which was circular and measured 0.27m in diameter and 0.19m deep. No finds were recovered from its single grey-brown sandy silt fill.

4.27.4 Trench 313 revealed a natural feature and a ditch. Ditch 31304 was not excavated, but ran just west of S-N, and its alignment suggests it was the southern continuation of ditch 30702 in Trench 307.

4.27.5 Trench 314 was situated to the east of Trench 313. It revealed a single ditch. Ditch 31402 was aligned NNW-SSE and measured 2.57m wide and 0.58m deep. It contained a dark grey-brown clay silt fill (31403) that contained ceramic building material of mid-15th to 18th-century date. This ditch was also seen in Trench 321 to the south. No continuation of this ditch was seen in Trench 300 to the north, although ditch 31402 may just have missed its west end.

4.27.6 Trench 320 revealed a natural feature (32003).

4.27.7 Trench 321 revealed the southern continuation of ditch 31402 in Trench 314. It was not excavated and the full width was not revealed by the trench but it had the same dark brownish-grey clay-silt fill as ditch 31402, and was comparable in size, measuring in excess of 1.8m wide.

4.28 Trenches 310, 312, 316-319, 323 and 324 (Fig. 46)

4.28.1 This group of trenches was situated in the south-eastern corner of Land Parcel 60, south of Trenches 303-306 and east of Trenches 308, 315 and 322 (Fig. 5).

- 4.28.2 Trench 310 revealed three ditches, none of which contained finds. Ditch 31007 was located at the western end of the trench. It was aligned NNW-SSE. It measured 0.33m wide and 0.12m deep and had a greyish-brown silty clay fill. To the east, ditch 31003 was aligned N-S and measured 0.85m wide and 0.36m deep. The single fill was a reddish-grey silty clay that produced a flint blade. Ditch 31005 was the easternmost of the three and was aligned NW-SE. It measured 0.83m wide and 0.12m deep, and contained a light brownish-grey silty clay, but no finds.
- 4.28.3 Trench 312 was located in the north-east of this group. It revealed two parallel ditches, a ditch terminus and four small pits or postholes.
- 4.28.4 Ditches 31202 and 31204 were aligned N-S across the central part of the trench. Ditch 31202 measured 1.4m wide and 0.16m deep. The fill was a light grey-brown silty clay (31303) from which CBM of 19th-century date was recovered. Ditch 31204 was located 3.5m to the east. It measured 0.93m wide and 0.14m deep and its light brownish-grey fill was devoid of finds. These trenches may form a trackway of post-medieval date, although no trace of either ditch was seen in Trench 324 to the south.
- 4.28.5 To the east of the two ditches was a ditch terminus or possibly an elongated pit (31211). It measured 0.7m wide and 0.16m deep and was filled with a light grey-brown silty clay that did not contain finds. A small pit to the south of this (31212) was not excavated.
- 4.28.6 Three possible postholes in a line (31208, 31206 and 31213) ran N-S across the eastern part of the trench. Each measured between 0.2m and 0.3m in diameter, and the first two were excavated, and were up to 0.2m deep, with fills (respectively 31209 and 31207) of greyish-brown silty clay. The fill of 31206 contained clay pipe fragments of later 17th or 18th century date, and the fill of 31208 post-medieval CBM.
- 4.28.7 Trenches 316 and 323 were situated in the west of this group and contained two ditches that extended through both trenches. The western ditch was 31605=32303, which was aligned NNW-SSE and measured 0.62m wide and 0.4m deep. Its blueish-grey fill (31606) suggests that the ditch contained standing water, and produced a struck flint. Ditch 31603=32305 was situated 9m further east and was also aligned NNW-SSE. It measured 0.8m wide and 0.5m deep, and its light grey-yellow clay silt fill contained five struck flints, burnt flints and a small amount of pottery of either prehistoric or Saxon date; the fragments were small, and it was not possible to date them more closely. A sample was taken for environmental remains, but produced a poor flot dominated by charcoal, with only a single charred glume fragment (sample 11). No continuation of this latter ditch was seen in Trench 309 to the north, although the projected line crossed this trench.
- 4.28.8 Trench 317 uncovered the western part of pit 31703 in the centre of the trench. It measured 0.66m wide and 0.14m deep, and had a blueish-grey silty clay fill. There were no finds from this, but a sample was taken for environmental remains, and produced charcoal dominated by oak heartwood (sample 10).
- 4.28.9 Trenches 318 and 324. Trench 318 revealed two ditches, one of which also appeared in Trench 324. Ditch 31805 was located at the western end of the trench, was aligned N-S and measured 0.75m wide and 0.18m deep. The light

grey-brown fill was devoid of finds. This ditch was in line with ditch 33802 in Trench 338 some way to the south, which may have been a continuation. Ditch 31803 was on a NNW-SSE alignment, and measured 0.9m wide and 0.23m deep. Its reddish-brown silt-clay fill did not contain finds. This ditch was on the same line as narrower ditch 32404 in Trench 324 to the south, so they were probably both part of the same boundary. Both trenches also revealed one natural feature, which were numbered 34807 and 32403.

- 4.28.10 Trench 319 revealed a layer/spread (31901) at the southern end of the trench. It was a dump of abraded bricks with no discernible other material present. A sample of the brick has been dated to the post-medieval period.

4.29 Trenches 326 and 328-332 (Figs 48 and 50)

- 4.29.1 This group of trenches was situated on the south side of Land Parcel 60, south of Trenches 320-322 and just east of the B186. Several trenches were positioned to investigate crop marks (Fig. 5).
- 4.29.2 Trench 326 revealed a natural feature (32603) in the central area of the trench.
- 4.29.3 Trench 328 revealed a natural feature (32804) in the western part of the trench and a ditch in the centre. Ditch 32802 was aligned broadly N-S and was in line with a linear cropmark recorded only 4m beyond the trench to the south. The ditch measured 0.77m wide and 0.13m deep and its brownish-grey sandy silt fill was devoid of finds.
- 4.29.4 Trenches 329 and 330 were positioned to investigate a linear cropmark but no features were revealed in either trench.
- 4.29.5 Trench 331 revealed a single ditch at the northern end of the trench. Ditch 33103 was aligned NNW-SSE and measured 0.78m wide and 0.27m deep. The greyish-brown clayey silt fill was devoid of finds. No continuation of this ditch was seen in either Trench 326 or Trench 325 to the north
- 4.29.6 Trench 332 was located across a linear crop mark. No feature was found where the cropmark crossed the trench, but a ditch was located c 4.5m to the west, which was in line with ditch 32802 to the north. This ditch (33202) was aligned N-S and measured 0.87m wide and 0.11m deep. There were no finds recovered from its brownish-grey clayey silt fill.
- 4.29.7 To the south-west of the ditch, a large feature (33204) was revealed corresponding to a large sub-circular cropmark, possibly a pond. The feature measured c 8m wide and contained two fills, but was not bottomed during the excavation (Fig. 50 section 33201). The upper of the two grey-brown sandy-silt fills (33207) contained nine sherds of pottery dated to the latter half of the 19th century, an iron bar and a nail. This feature appeared to overlap with ditch 33202, but the junction was not investigated.

4.30 Trenches 334 and 335 (Figs 49 and 50)

- 4.30.1 Trenches 334 and 335 were located at the far southern extent of Land Parcel 60, south of Trench 332 and within a narrow strip of land to the east of the B186, North Road (Fig. 4).
- 4.30.2 Trench 334 was located to investigate a linear cropmark that formed the north and east sides of a possible enclosure or field boundary. Ditch 33404 was found directly in line with the cropmark and measured 0.78m wide and 0.09m

deep (Fig. 50 section 33400). The single grey-brown silty-clay fill did not contain finds. A natural feature (33403) was revealed north of the ditch in the central area of the trench.

- 4.30.3 Trench 335 lay south of Trench 334 and crossed a large pit or ditch (33502). It measured 4.53m wide and was excavated to a depth of 0.69m, revealing two fills, but was not bottomed (Fig. 50 section 33500). The lower of the two exposed fills, a reddish-brown silty clay, contained four sherds of later prehistoric pottery and a little burnt flint, and the top fill (33505) contained burnt flint.

4.31 Trenches 338, 339 and 346-350 (Fig. 51)

- 4.31.1 This group of trenches was situated in the centre of Land Parcel 44, to the south and south-east of Trenches 324 and 319 in Land Parcel 60 (Fig. 5).
- 4.31.2 Trench 338 was orientated SW-NE and revealed a single ditch. Ditch 33802 was aligned N-S and measured 0.92m wide and 0.35m deep. Its single fill (33803) was a mottled blue-brown clay silt, and the only find was a lump of burnt flint.
- 4.31.3 Trench 339 lay north-east of Trench 338, and was orientated east-west. It revealed two ditches in the western half of the trench. The western ditch 33903 was aligned N-S, was 0.72m wide and 0.22m deep and contained two fills of grey-brown silty clay, neither containing finds. To the east, ditch 33906 was aligned NNW-SSE, measured 0.76m wide and 0.51m deep and contained a single mottled grey/orange silty clay fill (33907). Three sherds of Roman pottery, a flint blade and a small fragment of CBM of uncertain date were recovered from the fill. An environmental sample was taken from the fill, but produced only a little charcoal (sample 13). No continuation on the projected line of either ditch was seen in Trench 324 to the north or Trench 347 to the south.
- 4.31.4 Trench 346 lay south-east of Trench 339, and was also orientated east-west. A flint end scraper was recovered during machining of the topsoil. Below the subsoil the trench revealed four ditches aligned roughly N-S cut into the natural. All measured between 0.56m and 0.96m wide and between 0.13m and 0.62m deep. All had mottled orange and grey silty clay fills that were devoid of finds. Probable continuations of the two westernmost ditches were exposed in Trench 347 to the south, ditch 34603 being equivalent to 34702 and ditch 34611 to 34708.
- 4.31.5 The even spacing of these four ditches, and the common alignment with the two ditches in Trench 339, may suggest that they form part of a contemporary series of strips bounded by ditches.
- 4.31.6 Trench 347 lay south of Trench 346, and revealed two ditches. The western ditch (34702) measured 0.86m wide and 0.52m deep, and had three fills, the first of which was mottled blueish grey sandy silt devoid of finds. Above this a reddish brown clay silt (34704) contained a small amount of early Anglo-Saxon pottery (5th to 8th century date). The top fill was brownish grey sandy silt (34705), from which a single sherd of residual Roman pottery was recovered. This ditch is on the projected line of ditch 34603 to the north, and may be a continuation.

- 4.31.7 The eastern ditch (34708) was not excavated, but was almost certainly the continuation of ditch 34611 in Trench 346, with which it was in line.
- 4.31.8 Trenches 348 lay west of Trench 347 and contained a linear soilmark on a NNW-SSE alignment (34802). This was investigated and was judged to be of geological origin.
- 4.31.9 Trench 349 lay west of Trench 348, and contained two linear soilmarks and one circular one, possibly representing ditches and a pit. The linear soilmarks were both aligned NNW-SSE in the eastern half of the trench, and neither was of even width; the more westerly (34902) bulged in the middle, while the more easterly (34905) widened to the north. Neither was investigated, but 34902 is on the projected line of the ditch recorded further north as 31603 and 32305, so may possibly have been a continuation. No continuation of the eastern ditch (34905) was seen in Trench 337 to the north. The possible pit (34903) further west, was also investigated, but proved to be very shallow, and was judged to be of natural origin. Trench 350 also contained a similar natural feature (see Fig. 5).

4.32 Trenches 342-344 (Fig. 52)

- 4.32.1 This group of trenches was situated at the east end of Land Parcel 44, to the east of Trenches 340, 341 and 345, all of which were sterile (Fig. 5).
- 4.32.2 Trench 342 lay east of Trench 341, and contained a single natural feature 34203, which was aligned N-S.
- 4.32.3 Trench 343 lay east of 34202 and the subsoil produced a flint core, while another struck flint was recovered from the surface of the natural geology. Cut into the underlying geology were a ditch, an elongated pit and two natural features. Ditch 34303 was aligned N-S, and was 0.99m wide and 0.15m deep, with a greyish-brown soft sandy silt fill (34304) that contained later Roman pottery and animal bones.
- 4.32.4 East of this was a narrow elongated pit or gully 34305, which had a dark brownish-grey sandy silt fill. This was not excavated, but post-medieval CBM was recovered from its top.
- 4.32.5 East of 34305 was a pit or ditch (34306) 1.2m wide and 0.18m deep with a reddish-brown sandy silt fill (34307) that produced a flint flake. A large soilmark at the very east end of the trench had the appearance of a variation in the natural, and was not further investigated.
- 4.32.6 Trench 344 lay south-west of Trench 342, and was targeted to cross the east side of a cropmark forming a penannular enclosure open on the north side. The trench located a soilmark (34403) of compact, dark reddish-brown sandy silt corresponding to the cropmark, whose west edge was excavated and found to be only 0.11m deep, and was without finds. This soilmark was interpreted on site as of natural origin, but probably indicates an archaeological feature of early prehistoric date.

4.33 Undated and natural features

- 4.33.1 Many of the features from the evaluation were undated and comprised isolated linear ditches and pits, with occasional tree-throw holes and other natural features. In particular, a large number of small discrete natural features were

observed and excavated across Land Parcel 60. These were initially suspected to be postholes or small pits, but they did not form any particular pattern and contained no artefactual evidence, although some did contain charcoal fragments. On balance, these are likely to be tree root holes, and the charcoal is potentially evidence of deliberate land clearance.

4.34 Finds summary

- 4.34.1 **Prehistoric pottery.** Fifty-two sherds of prehistoric pottery were recovered from the evaluation. Most of the material was flint tempered and some contained sand; one grog-tempered sherd came from ditch 3502. Sherds with form or decoration indicating an early Iron Age date were noted, but most of the dating was based on fabrics. Sand-tempered sherds are more indicative of an Iron Age date, and the grog-tempered sherd may indicate an earlier prehistoric (Beaker/early Bronze Age) presence. Flint temper is ubiquitous in prehistoric pottery of most periods in the region, making concise dating very difficult in the absence of diagnostic material, and the spot-dates are therefore very broad, and in some cases tentative.
- 4.34.2 **Roman pottery.** A small assemblage of 48 sherds of pottery was recovered from the evaluation. While the pottery points to late Iron Age/early Roman, early-middle Roman and late Roman activity in the vicinity of the site, the condition and size of the assemblage suggests that the material had been redeposited and had been deposited incidentally, perhaps away from the focus of pottery use and initial discard. The northern edge of the site had only late Iron Age or early Roman material, the southern part having a wider range of Roman dates.
- 4.34.3 **Medieval and post-medieval pottery.** The evaluation provided 198 sherds of medieval and post-medieval pottery. The pottery mostly comprises ordinary domestic wares typical of this part of south Essex and covers a date range possibly from the 11th or 12th century to the late 19th or 20th century, though with some gaps evident. There is a concentration of material of high medieval (13th-14th century) date from the very north-west part of the site in Land Parcel 41 (Trenches 5, 13 and 7). Fifteen sherds of probable Anglo-Saxon pottery were also recovered from four trenches spread from north to south down the east edge of the site (Land Parcels 60 and 44).
- 4.34.4 **Clay pipe.** Four pieces of clay pipe were recovered from three contexts, with one from context 31207 dating to the late 17th-18th century and the other three from contexts 22405 and 23804 dating to the 19th century.
- 4.34.5 **Fired clay.** Small quantities of fired clay were recovered from the evaluation. All were indeterminate, amorphous fragments, 5-30mm in size, except for one piece with a flat, deliberately shaped surface. Neither date nor function can be determined, though the fragments from one context (7203) were probably debris from the burnt lining of a hearth or oven base (7202).
- 4.34.6 **Ceramic building materials.** A large quantity of CBM was recovered from the evaluation, amounting to 298 fragments weighing 13kg. The CBM assemblage includes some fairly large fragments, though no complete items were recovered. The assemblage is focused on the early post-medieval period (late 15th-16th century), and includes spreads in Trenches 9, 68 and 77 that probably derive from brick clamps, evidence of the early use of this field,

whose name is later recorded as Brick Kiln field. Fragments of field drain represent 19th-century agricultural improvement.

- 4.34.7 **Metals.** A total of 30 iron objects were recovered from the evaluation; much of the iron is heavily encrusted and this restricted interpretation and potential dating although it is likely to be post-medieval or modern in most cases. A single copper alloy nail was recovered from ditch 23803 and was of probable 19th/early 20th-century date.
- 4.34.8 **Flint.** The 34 worked flints were recovered from 30 individual contexts, with only 16 (or possibly 17) coming from cut features, and only one feature fill, 31604 in ditch 31603, containing multiple examples (5). The assemblage is overwhelmingly dominated by unretouched removals, alongside a single retouched tool and three cores. It includes a high proportion of blade-based material of Mesolithic/earlier Neolithic date, and even the group of 5 flints includes residual earlier pieces.
- 4.34.9 The burnt flint is likely to be of prehistoric date, and in the case of the assemblages from the two pits in Trench 135 may be broadly contemporary with the features from which it derives.
- 4.34.10 **Glass.** Thirteen fragments of glass were recovered from the evaluation. At least six drinking vessels are represented as well as some decorative window glass. All the glass recovered dates to the 19th and 20th centuries.

4.35 Environmental summary

- 4.35.1 **Charred plant remains and charcoal.** A total of twenty one bulk samples were recovered from the site and assessed for charred plant remains. These revealed the potential for the recovery of charred plant remains across the four parcels of land investigated. Many of the flots were poor, and most small, but those in Land Parcel 41 tended to be better-preserved, and several flots included charred grain or weed seeds in addition to charcoal. Some of these came from medieval features, for instance ditch 502, others from undated features including a probable oven, and in a few cases the flot contains material suitable for radiocarbon dating. One undated pit contained sprouted grain, which may indicate malting.
- 4.35.2 **Animal bones.** A total of 52 fragments of animal bone were recovered from the site. Animal bone recovered from LTC20 included seven possible sheep limb bones from context 508 and nine fragments of cattle bones from context 4703. Animal bone from LT41N20 included tiny fragments and a cattle molar from context 29106, 14 fragments of sheep/goat and cattle from context 29407 and two sheep/goat molars from context 34304. The small assemblage and condition of the material indicates that animal bone is unlikely to be recovered in significant quantity from any future excavations, although the presence of oyster shell in Trenches 235 and 238 does indicate that there are some deposits conducive to the preservation of bone.

5 Discussion

5.1 Reliability of field investigation

- 5.1.1 The layout of the excavated trenches provided good coverage of the site. Four trenches could not be excavated due to adverse ground conditions, although the absence of data from these locations is unlikely to affect the overall results of the investigation.
- 5.1.2 The archaeological features were clear against the underlying geology. Initially some deposits were sample excavated to establish if they were of geological or archaeological significance, and in several cases, putative archaeological features were shown to be no more than variations in natural deposits of sand or gravel.
- 5.1.3 During the 2020 phase of evaluation, the poor weather conditions hampered some of the investigations, and the prolonged periods during which staff were unable to work in the trenches meant that features were frequently flooded and covered in silt. However, there was a robust system in place to ensure that features were plotted and investigated regardless of the conditions. It is, therefore, unlikely that significant remains will have been missed as a result of these issues. The weather during the 2021 investigation was generally fine, and rain caused only minor inconvenience and did not affect the reliability of the results.

5.2 Interpretation

- 5.2.1 **Mesolithic/early Neolithic, later Neolithic and early Bronze Age.** Flint of potentially later Mesolithic or Neolithic date included a flint blade recovered from the ploughsoil or subsoil in Trench 119 and a small bladelet recovered from a ditch in Trench 403. A group of five pieces, including 3 blades and a blade core, came from ditch 31603, and a blade was also recovered from a ditch in Trench 310 and another in Trench 339. Flakes came from the ploughsoil/topsoil in Trenches 3, 169, 184, 294, 315, 339, 343 and 346, and single flakes were recovered from ditches in Trenches 84, 157 and 163 and from a pit in Trench 335. A single multiple platform core was recovered from the ploughsoil of Trench 12. No other finds of Neolithic date were recovered from any of the land parcels included in this report, but a sherd of grog-tempered pottery of potentially Beaker/early Bronze Age date came from a later ditch in Trench 35.
- 5.2.2 The flintwork demonstrates a presence in these land parcels during these periods, but is generally scattered, and was probably only transitory. There is a slight concentration at the eastern end of the site, half of the material coming from the eastern part of Land Parcels 44 and 60, centred around the core and blades in Trench 316. The core and blades presumably indicate a knapping episode whose remains were cut by the ditch. Other Mesolithic/Neolithic struck flints have been recovered from excavations at Manor Farm only a few hundred metres to the west (MoLA 2011), so the activity indicated by the evaluation is part of a wider presence in and around the site.

- 5.2.3 No dating evidence was recovered from either of the penannular large cropmark enclosures plotted in Land Parcels 60 and 44, so whether the flintwork had any relation to these is unclear, but such enclosures are likely to be later than the blade-based element of the flintwork assemblage. Both cropmarks corresponded to features containing reddish-brown fills characteristic of earlier prehistory, but the evaluation leaves some doubt about both, as in Trench 295 the ditch was offset from the cropmark, and insufficient was revealed to confirm their correspondence, and in Trench 344 the exposed soilmark was only minimally investigated, as it was believed to be natural. In neither case was the scale of hand-investigation sufficient to make an absence of finds significant. On balance, both of these cropmark enclosures remain potentially significant earlier prehistoric features.
- 5.2.4 A single flint flake was recovered from the ditch of a semi-circular cropmark feature in Trench 163, which may indicate an enclosure approximately 50m in diameter. The ditch was however less than 1m wide and only 0.22m deep, so is unlikely to represent an earlier prehistoric monument, and is more probably of later prehistoric date. The cropmark ring ditch to the south-east, also investigated in Trench 163, did not produce any finds, but at 15m in diameter is more likely to represent a burial monument or domestic enclosure of middle or late Bronze Age date (see below).
- 5.2.5 It should also be noted that unenclosed Neolithic and early Bronze Age settlement evidence is particularly hard to identify through evaluation trenching, as it largely comprises small discrete features that are often widely dispersed, and some of which may be without artefactual dating evidence and are only recognised through scientific dating.
- 5.2.6 **Later Bronze Age and Iron Age.** Sherds of one or other of these periods were recovered from both linear and discrete features in Land Parcel 41 in the western part of the site.
- 5.2.7 Ditch 3502 produced the largest number of sherds (22), which date from the late Bronze Age or early Iron Age except for one possibly residual Beaker sherd. The ditch may have formed part of an enclosure with a perpendicular ditch in the same trench, perhaps indicating a small enclosure of late Bronze Age or early Iron Age date here, although no further features of these periods were identified in adjacent trenches.
- 5.2.8 The other occurrences of pottery in the northern part of Land Parcel 41 were widely spread, coming from Trenches 9, 11, 49, 72 and 104. The associated features include a pit with evidence of burning close by, possibly on a hearth or oven and a ditch containing a pottery base, though the other occurrences may be residual in later features. Even if so, they indicate a spread of activity of this period across this area.
- 5.2.9 Small quantities of late Bronze Age–middle Iron Age date were recovered from three NE-SW aligned irregular ditches in Trenches 157 and 158, and a sherd of probable early Iron Age date was recovered from a ditch in Trench 149 to the north-east, alongside a cropmark on the same alignment. The function of these ditches is not clear, but they may belong to one or more trackways; cropmarks to the south-west of Dennis Road also follow this alignment, and suggest a wider prehistoric landscape defined by trackways or droveways and a rectilinear enclosure.

- 5.2.10 It is possible that the circular cropmark ring ditch and larger cropmark semicircle investigated in Trench 163 also relate to these ditches to the north and west, as although only a single flint flake was recovered from the former, and no finds from the latter, the 15m diameter ring ditch is of a type commonly dated to the middle or late Bronze Age in this part of Essex, for example at Mucking (Evans *et al.* 2016) and by evaluation for the scheme at the Whitfield South cropmark complex (OCA 2020, Trench 6). If the semi-circular enclosure is not merely part of a circular enclosure, then the open side lies towards the ditches.
- 5.2.11 One sherd of middle Bronze Age–middle Iron Age pottery was recovered from a small pit in Trench 180. No other features of prehistoric date were found in the trenches nearby, so this is unlikely to represent an extensive focus of activity.
- 5.2.12 Further east, and just west of the B186, four sherds of pottery from a large feature in Trench 335 could only be broadly dated to the middle Bronze Age–middle Iron Age period. This feature was not fully characterised, but as it was large, was not bottomed and also contained burnt flint, it may have been a waterhole. Such features are particularly common in the later Bronze Age, though are also found in later periods. It might have been associated with the enclosure or field evident as a cropmark to the north and west, and investigated in Trench 334 without producing finds. There were no similarly dated features in Trench 334, nor in the two trenches across the B186 to the west, but does suggest potential for further later prehistoric evidence in this southern part of Land Parcel 60.
- 5.2.13 Few finds were recovered that can be dated firmly to the Iron Age. A ditch in Trench 26 contained five sherds of Iron Age date, and ditch 14905 contained an early Iron Age rim sherd. Other sherds with sandy fabrics may also be Iron Age, although sand is found in the late Bronze Age on occasions.
- 5.2.14 A group of cropmarks just to the west of the B186, which were investigated by Trenches 284, 285 and 287, did confirm the presence of a small ring ditch with a projected diameter of around 10m, and although a smaller curvilinear cropmark did not correspond to an archaeological feature, a narrow and curving gully was found in Trench 284 that might represent another small curvilinear enclosure. These cropmarks had previously been interpreted as probably Iron Age, but none of the discrete cropmarks in this area proved to be pits, weakening this interpretation. If the possible pit inside the ring ditch, which was deliberately omitted from the evaluation, is genuine, it might suggest an internal burial for a monument of later Bronze Age date, but it is equally possible that this cropmark does not mark an archaeological feature, in which case the enclosure might instead be Iron Age or even Romano-British. A sherd of Roman pottery was recovered from the curving gully in Trench 284, strengthening this interpretation (see also below).
- 5.2.15 **Late Iron Age/Roman.**
- 5.2.16 Two ditches in Trench 1 at the very north-west edge of the site produced late Iron Age or early Roman pottery, and specifically Early Roman pottery dated AD 43-70 was recovered from Trench 49. Roman enclosures were found at Manor Farm only a few hundred metres to the west of the site (MoLA 2011), and the activity in this corner of the site may well relate to this.

- 5.2.17 A sherd of late Iron Age/early Roman pottery was also recovered from ditch 25405 in a trench in the south-west corner of Land Parcel 60. This feature is the most westerly of three ditches in the trench, all orientated on the same alignment. None were seen in neighbouring trenches, and the context and purpose of these ditches is unclear. A third area of late Iron Age/early Roman activity is represented by pottery in Trenches 294 and 298, both on the north-east boundary of Land Parcel 60. These all presumably represent activity peripheral to settlement foci outside the limits of the site.
- 5.2.18 Roman pottery of early to middle Roman date came from Trenches 271 and 277, two adjacent trenches just west of the B186, and there are a variety of undated ditches and gullies in the vicinity that may well be associated. It is possible that ditches in Trenches 271, 272 and 277 might all be elements of one enclosure, and curving gullies in Trench 276 to the west are likely to belong to penannular enclosures, that in the south-west part of the trench being approximately 10m across. The enclosures are of similar size to the cropmark enclosures to the south in Trenches 284 and 285, and the sherd from the gully in Trench 284, while not phased within the Roman period, is likely to belong to the same small focus of Roman activity.
- 5.2.19 One sherd of late Roman pottery came from Trench 343 at the east end of Land Parcel 40. Sherds of Roman pottery whose phase within the period could not be identified also came from Trenches 339 and 347 within this land parcel, suggesting a possible area of later Roman activity peripheral to a focus outside the site to the south or north-east.
- 5.2.20 Other sherds with a broad Roman date came from Trenches 173, 187 and 235. Trenches 173 and 187 contained N-S aligned narrow ditches that contained small amounts of Roman pottery. These may represent field or plot boundaries or other drainage ditches peripheral to settlement activity elsewhere, or merely surface material from manuring incorporated into later boundaries. The sherd from Trench 235 is an isolated findspot from a ditch whose extent and purpose is unclear.
- 5.2.21 The small size of the pottery sherds reinforces the view that most of the activity within the site was peripheral to foci elsewhere, although the group of enclosures just west of the B186 suggests a greater concentration of activity, although this may not have been primarily domestic in nature.
- 5.2.22 **Saxon** The evaluation uncovered features with pottery suggesting a focus for Anglo-Saxon activity in the north-east corner of Land Parcel 60. Trench 294 revealed a large N-S aligned ditch, measuring just under 5m wide, which may represent a boundary of early Saxon date. Six sherds of pottery dating to the 5th–7th century AD were recovered from the fill. A possible enclosure ditch in Trench 298, just to the south of Trench 294 yielded two sherds of late Saxon shelly ware, suggesting a possible continuation or repeated focus of activity in the latter part of the period. Another possible focus of Anglo-Saxon activity is in Land Parcel 44, in the far south-east of the site, where Trench 347 revealed a ditch that contained two sherds of pottery of 5th–8th century date.
- 5.2.23 Possible late Saxon activity has been recorded to the west of the site, adjacent to the M25 (OA 2019c) and the site was likely part of the manorial estate of North and South Ockendon. The Domesday Survey records the estate as very large, at 90 households.

- 5.2.24 **Medieval.** The evaluation uncovered features with pottery spanning the period from c 1000 to 1350. Outside the evaluation area, there are a number of medieval settlements, and several cropmarks have been identified as being of possible medieval date, although these were not excavated during the current phase of work.
- 5.2.25 In the north-west part of the site (that part now within Havering), the earliest medieval pottery dates to the 11th and 12th centuries and comprises domestic wares common to this area, with the majority of the sherds coming from ditch 4703. Clearer evidence of domestic activity is evident in the 13th-14th centuries, when ditches and pits in Trenches 5 and 13, and a ditch in Trench 7, contain sizeable assemblages of domestic pottery. Although no structural evidence was seen, this activity is likely to be very close to a focus of settlement of this date, probably the medieval manor and surrounding settlement of North Ockendon.
- 5.2.26 A little pottery of late Saxon or early medieval date was recovered from Trench 298 in the very north-east corner of Land Parcel 60, but the only other concentration of material, of 12th-14th century date, was found in Trenches 290 and 291 at the very southern edge of the site, near to where Groves Manor was built in the 16th century. The two ditches that date to the medieval period are broadly perpendicular to one another and may form part of a rectilinear enclosure that extends to the south-east. The small amount of pottery recovered comprises domestic wares – cooking pots and jugs – which are typical to this area of Essex and are likely to be from small farmsteads that were later incorporated into the larger manorial estates.
- 5.2.27 **Post-medieval.** The evaluation uncovered a number of features which contained pottery, glass, CBM and metal objects that provided a post-medieval date.
- 5.2.28 Post-medieval finds were recovered from the eastern ditch of the paired cropmark ditches running north towards North Ockendon that were investigated in Trench 107, which is not surprising, as this boundary corresponded to one visible on historic mapping of the 19th century and later. Post-medieval finds were also recovered from the very shallow ditch or hollow way to the east of this.
- 5.2.29 There were, however, three other parallel ditches further west, and no finds came from any of these three. The easternmost of these three ditches is the other one visible as a cropmark, and this is clearly contemporary with an enclosure on the east side, as there is a gap in the cropmark for the south-western entrance to this enclosure. This enclosure is cut across by the cropmark ditch to its east, which corresponds to the boundary shown on 19th century maps, and no gap for entrance to the enclosure is evident in the later ditch, suggesting that the enclosure and the western ditch are earlier, though by how much is unclear. It is therefore likely that these ditches may represent several phases of this linear boundary, perhaps extending back into the early post-medieval period when North Ockendon Hall was built.
- 5.2.30 As well as the ditches that date to the post-medieval period, there was clearly an industrial focus around Trenches 9, 68 and 77 in the form of the remains of a circular brick-built structure (6808), heat-affected soils and charcoal-rich deposits. The nature of the industrial activity is presently not fully understood.

During fieldwork, the structure was interpreted as a brick kiln, but as argued by Cynthia Poole (Appendix B.5), the feature may more plausibly represent a circular brick-built lime kiln. Poole notes that while roof and floor tile were fired in kilns, prior to the 19th-century bricks were more commonly fired in brick clamps. The field name of 'Brick Kiln Field', attested from historical records, may therefore refer to the presence of a kiln or kilns built of brick, although the field's earlier name of 'Brickclamps' does indeed hint at brick production in the area. It is also possible that brick clamps were succeeded by a kiln built to fire the bricks, at which point the field name also changed. A layer incorporating CBM recovered from Trench 9 may also derive from brick manufacture, although only a spread of broken-up and redeposited material was identified within the evaluation trench.

- 5.2.31 In any case, the bricks recovered from the structure all date to the late 15th-16th century, and the roof tiles recovered are broadly contemporary. This activity is therefore quite likely to be related to the construction of nearby North Ockenden Hall in the early 16th century.
- 5.2.32 Glass bottles for milk, wine and beer of 19th-century date were all recovered from the evaluation and are likely to have been discarded by agricultural workers working on the land. Ceramic land drains were found across the majority of the site, and fragments recovered from these date from the 19th century showing how the land was improved for agriculture during this period.

5.3 Evaluation objectives and results

General Aims

- 5.3.1 **Aims i-iii.** This evaluation established the presence of archaeological remains from the Mesolithic/early Neolithic, Bronze Age, Iron Age, Roman, Anglo-Saxon, later medieval and post-medieval periods. The layout of trenches also helped to establish the reliability of the cropmark data and by investigation areas both with and without cropmarks.
- 5.3.2 **Aim iv.** The evaluation demonstrated that the archaeological remains encountered were generally truncated by modern agriculture. The evaluation also established that colluvial sediments are not present within areas investigated and therefore buried archaeological horizons from the Holocene are not present. It also helped to clarify the location of the underlying head deposits.
- 5.3.3 **Aims v-vi.** The evaluation established the date of the remains present, the state and preservation of the archaeological artefacts. Due to the paucity of material recovered there is limited evidence about the economy and status of the past inhabitants of the site.
- 5.3.4 **Aim vii.** Paleo-environmental samples were recovered and have demonstrated the state of preservation and potential for environmental information.

Site Specific Aims

- 5.3.5 **Aim xiii.** The results of the evaluation demonstrate potential for archaeological remains within the site to contribute to the objectives of the revised East of England Research Framework, for example the examination of the

interrelationship between Bronze Age settlements and monuments (Medlycott 2011, 20). The site may also contribute to the objectives of the Greater Thames Estuary Historic Environment Research Framework (Heppell 2010). The possible kiln-built structure in Trench 68, for example, is relevant to framework objectives 5B (to further the understanding of the evolution of the historic built environment along the estuary with special reference to structural form and function) and 7A (to develop an understanding of the estuary's industrial archaeology remains).

- 5.3.6 **Aim xiv.** The evaluation showed that the ring ditches identified in the cropmark survey corresponded with below-ground archaeological features. Although none of the excavated slots provided Bronze Age artefacts, material from this period was recovered from elsewhere in the evaluation, confirming that there was a level of Bronze Age activity. No mortuary evidence was recovered from the site.
- 5.3.7 **Aim xv.** The lack of dating evidence makes it difficult to ascertain a relationship between the ring ditches and surrounding features. However, the curvilinear ditches in Trenches 276 and 284 are more consistent with roundhouse gullies and are potentially indicative of settlement evidence.
- 5.3.8 **Aim xvi.** The evaluation generally clarified the accuracy and quality of the cropmark evidence and provided a fair representation of the range, quantity and types of larger archaeological features present within the site. Most of the cropmarks proved to correspond to archaeological features, although in the case of one of the larger cropmark enclosures, whether the cropmark was of natural or archaeological origin remains in doubt. Some discrete cropmarks, particularly the cluster just west of the B186, were shown not to relate to archaeological features, although one ring ditch in this area was confirmed as archaeological by the trenching. Conversely, some cropmarks proved to reflect only part of the linear boundaries below ground, as was the case in Trenches 157-160 on the west side of the site.
- 5.3.9 **Aim xvii.** The discrete pits in the south-east of the parcel identified in the cropmark survey did not correlate with any archaeological features recorded in the trenches. As has been noted elsewhere on the scheme, these pit-like cropmarks were probably created by patches of silt and sand within the underlying gravel natural.
- 5.3.10 **Aim xviii.** The possible field boundaries identified on site have produced artefacts with dates ranging from the Bronze Age to post-medieval period, with some providing a range of dates from the same fill material. This may suggest that boundaries were in use for a long period of time, but more likely indicates that earlier artefacts were widely dispersed and incorporated as residual material.
- 5.3.11 **Aim xix.** The green lane identified in historic maps crossing Land Parcel 41 was not identified in any of the evaluation trenches excavated.
- 5.3.12 **Aim xx.** The evaluation uncovered evidence of industrial activity at the western edge of Land Parcel 41. This relates to the use of a brick-built structure, possibly a lime kiln, though from historical records brick manufacture may also have taken place within or close to the site. The industrial activity

was dated to the 15th-16th centuries and was probably associated with the construction of North Ockenden Hall.

- 5.3.13 **Aim xxi.** No evidence for post-medieval clay and sand extraction was identified during the evaluation, though presumably local brickmakers will have acquired these materials from somewhere close to the site.
- 5.3.14 **Aim xxii.** No confirmed medieval farmsteads were identified by the evaluation, although the pottery and other finds point to domestic activity in close proximity to the site.

Appendix A Trench Tables

Trench 1							
General description					Orientation		NE-SW
Trench revealed four pits and one ditch running N-S. Consists of ploughsoil and subsoil overlying reddish brown sandy clay/gravel natural.					Length (m)		30
					Width (m)		2
					Avg. depth (m)		0.4
Context No.	Type	Fill Of	Width (m)	Depth (m)	Description	Finds	Date
100	Layer			0.26	Ploughsoil. Brown grey silty clay.		
101	Layer				Natural. Brown orange sandy clay and gravel.		
102	Cut		0.67	0.26	Pit		
103	Fill	102	0.67	0.25	Primary Fill. Light brown grey silty clay.	Pot	20BC-AD150
104	Cut		0.5	0.29	Pit		
105	Fill	104	0.5	0.29	Primary Fill. Light brown grey silty clay.	Pot, <S4>	20BC-AD150
106	Cut		1.68	0.4	Ditch		
107	Fill	106	1.68	0.4	Other Fill. Brownish grey sandy clay		
108	Cut		0.79	0.25	Pit		
109	Fill	108	0.37	0.08	Primary Fill. Dark blue grey silty clay.	<S5>	
110	Fill	108	0.79	0.25	Secondary Fill. Light brown grey silty clay.		
111	Cut		0.44	0.17	Pit		
112	Fill	111	0.44	0.17	Primary Fill. Light greyish brown silty clay.		
113	Layer			0.14	Subsoil. Reddish brown silty clay.		
Trench 2							
General description					Orientation		N-S
Trench revealed one pit. Consists of ploughsoil and subsoil c					Length (m)		30
					Width (m)		2
					Avg. depth (m)		0.4
Context No.	Type	Fill Of	Width (m)	Depth (m)	Description	Finds	Date
200	Layer			0.3	Ploughsoil. Dark greyish brown silty clay.		

201	Layer				Natural. Dark reddish brown silty clay.		
202	Cut		0.43	0.17	Pit		
203	Fill		0.43	0.17	Primary Fill. Greyish brown clayey silt.		
204	Layer			0.1	Subsoil. Reddish brown silty clay.		

Trench 3

General description					Orientation		NW-SW
Trench revealed one ditch. Trench consists of ploughsoil and subsoil overlying a sandy clay natural with gravel patches					Length (m)		30
					Width (m)		2
					Avg. depth (m)		0.4

Context No.	Type	Fill Of	Width (m)	Depth (m)	Description	Finds	Date
300	Layer			0.3	Ploughsoil. dark grey silty clay		
301	Layer				Natural. dark reddish brown silty clay		
302	Cut		0.54	0.11	Ditch		
303	Fill	302	0.54	0.11	Primary Fill. dark greyish brown clayey silt		
304	Layer			0.1	Subsoil. Greyish brown silty clay		

Trench 4

General description					Orientation		NE-SW
Trench revealed one ditch. Trench consists of ploughsoul overlying a subsoil over a clayey sand natural					Length (m)		30
					Width (m)		2
					Avg. depth (m)		0.4

Context No.	Type	Fill Of	Width (m)	Depth (m)	Description	Finds	Date
400	Layer			0.32	Ploughsoil. Dark grey firm clayey silt		
401	Layer			0.08	Subsoil. Dark greyish brown soft sandy silt		
402	Layer				Natural. Dark reddish brown clayey sand		
403	Cut		0.8	0.24	Ditch		
404	Fill	403	0.8	0.24	Primary Fill. Soft greyish brown silty sand		

Trench 5

General description					Orientation		E-W
---------------------	--	--	--	--	-------------	--	-----

Trench revealed three pits and three ditches. Trench consists of ploughsoil and subsoil overlying clayey sand natural.						Length (m)	30
						Width (m)	2
						Avg. depth (m)	0.36
Context No.	Type	Fill Of	Width (m)	Depth (m)	Description	Finds	Date
500	Layer			0.24	Ploughsoil. Dark greyish brown clayish silt		
501	Layer				Natural. Reddish brown sandy clay gravel		
502	Cut		0.39	0.23	Ditch		
503	Fill	502	0.39	0.23	Other Fill. Grey sandy clay with charcoal	Pot, Nail?, <S6>	c 1270-1350
504	Cut		0.64	0.24	Pit		
505	Fill	504	0.5	0.1	Other Fill. Light brownish grey clayey sand.		
506	Fill	504	0.68	0.14	Deliberate Backfill. Greyish brown clayey sand	Pot, <S7>	C 1100-1325
507	Cut		1	0.18	Pit		
508	Fill	507	1	0.18	Other Fill. Greyish brown clayey sand	Pot, AB	C 1270-1350
509	Cut		0.7	0.1	Pit		
510	Fill	509	0.7	0.1	Other Fill. Greyish brown clayey sand		
511	Cut		0.43	0.08	Ditch		
512	Fill	511	0.43	0.08	Other Fill. Greyish brown clayey sand		
513	Cut		0.36	0.18	Ditch		
514	Fill	513	1.36	0.18	Other Fill. Brownish grey clayey sand		
515	Layer			0.12	Subsoil. Yellowish brown sandy clay		

Trench 6

General description						Orientation	E-W
Trench revealed one ditch. Consists of ploughsoil and subsoil overlying natural geology of silty clay and gravel that has the appearance of being gleyed. Perhaps seasonally or for a time was waterlogged.						Length (m)	30
						Width (m)	2
						Avg. depth (m)	0.34
Context No.	Type	Fill Of	Width (m)	Depth (m)	Description	Finds	Date
600	Layer			0.17	Ploughsoil. Dark brown sandy silt.		
601	Layer			0.17	Subsoil. Red brown Sandy silt		
602	Cut		1.3	0.21	Ditch		
603	Fill		1.3	0.21	Tertiary Fill. Lght grey brown clay silt		
604	Layer				Natural. Pale brown red, clayey silt		

Trench 7							
General description					Orientation		SE-NW
Trench revealed one ditch. Trench consists of ploughsoil and subsoil overlying a sandy gravel natural that has the appearance of being gleyed. Perhaps seasonally or for a time was waterlogged.					Length (m)		30
					Width (m)		2
					Avg. depth (m)		0.39
Context No.	Type	Fill Of	Width (m)	Depth (m)	Description	Finds	Date
700	Layer			0.31	Ploughsoil. Dark grey firm clayey silt		
701	Layer				Natural. Brownish grey sandy gravel		
702	Cut		2.53	0.35	Ditch. E-W		
703	Fill	702	2.53	0.35	Primary Fill. Firm brownish grey sandy silt	Pot	C 1300-1400
704	Layer			0.08	Subsoil. Greyish brown silty clay.		
Trench 8							
General description					Orientation		E-W
Trench devoid of archaeology. Consists of ploughsoil and subsoil above a sandy clay gravel natural.					Length (m)		30
					Width (m)		2
					Avg. depth (m)		0.58
Context No.	Type	Fill Of	Width (m)	Depth (m)	Description	Finds	Date
800	Layer			0.36	Ploughsoil. Blackish grey silt.		
801	Layer			0.22	Subsoil. Brown slightly clayey silt.		
802	Layer				Natural. Reddish Brown- Light yellowish brown, clayey silt with patches of gravel.		
803	Cut		0.43	0.14	Natural Feature. Greyish brown, slightly sandy silt.		
804	Cut		0.71	0.16	Natural Feature. Greyish brown sandy silt		
805	Cut		0.75	0.29	Natural Feature. Greyish brown, sandy silt.		
Trench 9							
General description					Orientation		N-S
Trench revealed a deposit of building material relating to kiln debris. Trench consists of ploughsoil and subsoil overlying a sandy clay natural					Length (m)		30
					Width (m)		2
					Avg. depth (m)		0.4

Context No.	Type	Fill Of	Width (m)	Depth (m)	Description	Finds	Date
900	Layer			0.3	Ploughsoil. dark grey clayey silty		
901	Layer				Natural. Dark reddish brown sandy clay with gravel patches		
902	Layer		2.36	0.16	Other Layer. Deposit of building material relating to kiln debris. Greyish brown clayey silt	Pot	MBA-MIA
903	Layer			0.1	Subsoil. Greyish brown silty clay		

Trench 10

General description	Orientation	N-S
Devoid of archaeology. Consists of ploughsoil and subsoil above a sandy clay gravel natural.	Length (m)	30
	Width (m)	2
	Avg. depth (m)	0.39

Context No.	Type	Fill Of	Width (m)	Depth (m)	Description	Finds	Date
1000	Layer			0.27	Ploughsoil. Greyish brown ploughsoil		
1001	Layer			0.12	Subsoil. Light greyish brown, silty clay		
1002	Layer				Natural. Orange brown sandy clay and gravel		

Trench 11

General description	Orientation	E-W
Trench revealed two ditches. Trench itself consisted of ploughsoil and subsoil overlying natural geology of silty clay with gravel	Length (m)	30
	Width (m)	2
	Avg. depth (m)	0.4

Context No.	Type	Fill Of	Width (m)	Depth (m)	Description	Finds	Date
1100	Layer			0.33	Ploughsoil. Brown grey silty clay.		
1101	Layer			0.07	Subsoil. Light greyish brown silty clay.		
1102	Layer				Natural. Reddish brown sandy clay and gravel.		
1103	Cut		1.06	0.27	Ditch		
1104	Fill	1103	1.06	0.27	Primary Fill. Light brownish grey clayey silt.		
1105	Cut		0.96	0.34	Ditch		

1106	Fill	1105	0.82	0.18	Primary Fill. Light yellowish grey clayey silt.		
1107	Fill	1105	0.96	0.16	Secondary Fill. Light brownish grey clayey silt.	Pot	LBA-MIA

Trench 12

General description						Orientation	N-S
Trench revealed one ditch. Ploughsoil and subsoil overlying a sandy gravel natural						Length (m)	30
						Width (m)	2
						Avg. depth (m)	0.4
Context No.	Type	Fill Of	Width (m)	Depth (m)	Description	Finds	Date
1200	Layer			0.31	Ploughsoil. Dark grey firm clayey silt		
1201	Layer				Natural. Dark reddish brown sandy clayey gravel		
1202	Cut		2.24	0.12	Ditch. E-W		
1203	Fill	1202	2.24	0.12	Primary Fill. Dark brownish grey soft sandy silt		
1204	Layer			0.09	Subsoil. Greyish brown silty clay.		

Trench 13

General description						Orientation	E-W
Trench revealed two ditches and three pits. Trench consists of a ploughsoil and subsoil overlying a sandy clay gravelly natural						Length (m)	30
						Width (m)	2
						Avg. depth (m)	0.41
Context No.	Type	Fill Of	Width (m)	Depth (m)	Description	Finds	Date
1300	Layer			0.34	Ploughsoil. Dark grey firm clayey silt		
1301	Layer				Natural. Dark reddish brown sandy clay with gravel		
1302	Cut		3.04	0.61	Ditch. N-S	Pot	c 1250-1300
1303	Fill	1302	3.04	0.61	Primary Fill. Firm mid brownish grey clayey silt	Pot, <S9>	c 1250-1300
1304	Cut		0.79	0.19	Ditch. N-S		
1305	Fill	1304	0.79	0.19	Primary Fill. Soft light brownish grey sandy silt		
1306	Cut		0.71	0.1	Pit		
1307	Fill	1306	0.71	0.1	Primary Fill. Light grey firm clayey silt		
1308	Cut		0.74	0.16	Pit		

1309	Fill	1308	0.74	0.15	Primary Fill. Light grey firm clayey silt		
1310	Cut		0.53	0.24	Pit		
1311	Fill	1310		0.1	Primary Fill. Dark greyish brown firm clayey silt		
1312	Fill	1310	0.54	0.16	Secondary Fill. Dark brownish grey soft clayey silt	<S8>	
1313	Layer			0.07	Subsoil. Greyish brown silty clay.		

Trench 14

General description						Orientation	N-S
Trench devoid of archaeology. Consists of ploughsoil and subsoil overlying natural geology of gravel that has the appearance of being gleyed. Perhaps seasonally or for a time was waterlogged.						Length (m)	30
						Width (m)	2
						Avg. depth (m)	0.5
Context No.	Type	Fill Of	Width (m)	Depth (m)	Description	Finds	Date
1400	Layer			0.34	Ploughsoil. Dark greyish brown silty clay.		
1401	Layer			0.16	Subsoil. Greyish brown silty clay.		
1402	Layer				Natural. Bluish grey gravel and sand.		

Trench 15

General description						Orientation	E-W
Trench devoid of archaeology. Consists of ploughsoil and subsoil overlying natural geology of gravel and sand that has the appearance of being gleyed. Perhaps seasonally or for a time was waterlogged.						Length (m)	30
						Width (m)	2
						Avg. depth (m)	0.45
Context No.	Type	Fill Of	Width (m)	Depth (m)	Description	Finds	Date
1500	Layer			0.34	Ploughsoil. Dark greyish brown silty clay.		
1501	Layer			0.09	Subsoil. Greyish brown silty clay.		
1502	Layer				Natural. Bluish grey gravel and sand.		

Trench 16

General description						Orientation	SSE-NNW
Trench revealed one ditch. Consists of ploughsoil and subsoil overlying natural geology of silty clay and gravel. that has the appearance of being gleyed. Perhaps seasonally or for a time was waterlogged.						Length (m)	30
						Width (m)	2
						Avg. depth (m)	0.52
Context No.	Type	Fill Of	Width (m)	Depth (m)	Description	Finds	Date

1600	Layer			0.34	Ploughsoil. Dark greyish brown silty clay.		
1601	Layer			0.18	Subsoil. Greyish brown silty clay.		
1602	Layer				Natural. Orange brown silty clay and grey gleyed gravel.		
1603	Cut		0.68	0.26	Ditch		
1604	Fill	1603	0.6	0.14	Secondary Fill. Light brownish grey silty clay.		
1605	Fill	1603	0.62	0.12	Tertiary Fill. Light yellowish grey silty clay.		
1606	Cut		0.44	0.07	Natural Feature. Bluish grey silty clay		

Trench 17

General description	Orientation	E-W
Trench devoid of archaeology. Consists of ploughsoil and subsoil overlying natural geology of sandy clay and gravel.	Length (m)	30
	Width (m)	2
	Avg. depth (m)	0.34

Context No.	Type	Fill Of	Width (m)	Depth (m)	Description	Finds	Date
1700	Layer			0.28	Ploughsoil. Dark greyish brown silty clay.		
1701	Layer				Natural. Brownish orange sandy clay and gravel.		
1702	Layer			0.06	Subsoil. Greyish brown silty clay.		

Trench 18

General description	Orientation	N-S
Trench devoid of archaeology. Trench consists of ploughsoil and subsoil overlying a sandy clay natural with gravel	Length (m)	30
	Width (m)	2
	Avg. depth (m)	0.52

Context No.	Type	Fill Of	Width (m)	Depth (m)	Description	Finds	Date
1800	Layer			0.37	Ploughsoil. dark grey clayey silt		
1801	Layer				Natural. Dark reddish brown sandy clay with gravel patches		
1802	Cut		1.44	0.22	Natural Feature. Dark greyish brown sandy silt		
1803	Layer			0.15	Subsoil. Greyish brown silty clay.		

Trench 19							
General description					Orientation		NE-SW
Trench devoid of archaeology. Ploughsoil and subsoil above a sandy clay natural with gravels.					Length (m)		30
					Width (m)		2
					Avg. depth (m)		0.46
Context No.	Type	Fill Of	Width (m)	Depth (m)	Description	Finds	Date
1900	Layer			0.3	Ploughsoil. Dark greyish brown silty clay		
1901	Layer			0.16	Subsoil. Light greyish brown silty clay		
1902	Layer				Natural. Light orange brown sandy clay and gravel.		
Trench 20							
General description					Orientation		N-S
Trench devoid of archaeology. Trench consists of ploughsoil and subsoil overlying a sandy clay gravelly natural					Length (m)		30
					Width (m)		2
					Avg. depth (m)		0.49
Context No.	Type	Fill Of	Width (m)	Depth (m)	Description	Finds	Date
2000	Layer			0.38	Ploughsoil. Dark grey clayey silt		
2001	Layer				Natural. Dark reddish brown sandy clay with gravel inclusions		
2002	Cut		0.57	0.17	Natural Feature. dark brownish grey sandy silt.		
2003	Cut		0.7	0.08	Natural Feature. Irregular natural pit. Soft dark brownish grey sandy silt with charcoal flecks		
2004	Void						
2005	Layer			0.11	Subsoil. Greyish brown silty clay.		
Trench 21							
General description					Orientation		E-W
Trench devoid of archaeology. Consisted of ploughsoil and subsoil overlying natural geology of clays sand and gravel.					Length (m)		30
					Width (m)		3
					Avg. depth (m)		0.38
Context No.	Type	Fill Of	Width (m)	Depth (m)	Description	Finds	Date

2100	Layer			0.3	Ploughsoil. Dark grey brown, sandy silt.		
2101	Layer			0.08	Subsoil. Reddish brown sandy clay silt.		
2102	Layer				Natural. Sandy clay and gravels.		

Trench 22

General description						Orientation	N-S
Trench devoid of archaeology. Consists of ploughsoil and subsoil overlying natural geology of sand and gravel that has the appearance of being gleyed. Perhaps seasonally or for a time was waterlogged.						Length (m)	30
						Width (m)	2
						Avg. depth (m)	0.39
Context No.	Type	Fill Of	Width (m)	Depth (m)	Description	Finds	Date
2200	Layer			0.26	Ploughsoil		
2201	Layer			0.13	Subsoil		
2202	Layer				Natural		
2203	Cut		2.22	0.1	Natural Feature		
2204	Void						
2205	Void						
2206	Void						
2207	Void						
2208	Void						
2209	Void						
2210	Void						
2211	Void						

Trench 23

General description						Orientation	NE-SW
Trench revealed one ditch. Consists of ploughsoil and subsoil overlying natural geology of silty clay and gravel that has the appearance of being gleyed. Perhaps seasonally or for a time was waterlogged.						Length (m)	30
						Width (m)	2
						Avg. depth (m)	0.42
Context No.	Type	Fill Of	Width (m)	Depth (m)	Description	Finds	Date
2300	Layer			0.28	Ploughsoil. Dark greyish brown silty clay.		
2301	Layer			0.14	Subsoil. Light greyish brown silty clay		
2302	Layer				Natural. Light yellowish brown silty clay and grey gravel.		
2303	Cut		1.38	0.4	Ditch		

2304	Fill	2303	1.38	0.4	Secondary Fill. Brownish grey silty clay		
Trench 24							
General description					Orientation		E-W
Trench revealed one ditch. Consists of ploughsoil and subsoil overlying a sandy and clay silt natural with gravel bands.					Length (m)		30
					Width (m)		2
					Avg. depth (m)		0.5
Context No.	Type	Fill Of	Width (m)	Depth (m)	Description	Finds	Date
2400	Layer			0.3	Ploughsoil. Blackish grey, silt.		
2401	Layer			0.2	Subsoil. Greyish brown, slightly clayey silt.		
2402	Layer				Natural. Reddish brown, slightly clayey and sandy silt with gravel inclusions.		
2403	Cut		0.76	0.2	Ditch		
2404	Fill	2403	0.76	0.2	Primary Fill. Light yellowish brown with reddish brown patches. Sandy silt.		
2405	Cut		0.74	0.06	Natural Feature. Light greyish brown, sandy silt.		
Trench 25							
General description					Orientation		NW-SE
Trench revealed one posthole. Consists of ploughsoil and subsoil overlying sandy clay and gravel.					Length (m)		30
					Width (m)		2
					Avg. depth (m)		0.54
Context No.	Type	Fill Of	Width (m)	Depth (m)	Description	Finds	Date
2500	Cut		0.34	0.1	Posthole		
2501	Fill	2500	0.34	0.1	Other Fill. Light brownish grey sandy clay with charcoal		
2502	Layer			0.34	Ploughsoil. Dark greyish brown silty clay.		
2503	Layer			0.2	Subsoil. Light greyish brown silty clay.		
2504	Layer				Natural. Brownish orange silty clay		
Trench 26							

General description						Orientation		E-W
Trench revealed one ditch. Consists of ploughsoil and subsoil overlying natural geology of sandy clay and gravel.						Length (m)		30
						Width (m)		20
						Avg. depth (m)		0.49
Context No.	Type	Fill Of	Width (m)	Depth (m)	Description	Finds	Date	
2600	Layer			0.3	Ploughsoil. Dark brown grey Sandy silt			
2601	Layer			0.19	Subsoil. Yellow red clayey silt			
2602	Layer				Natural. Pale brown red clayey silt heavily mixed with gravel pockets			
2603	Cut		1.34	0.23	Ditch			
2604	Fill		1.34	0.23	Other Fill. Greyish brown silty sand.	Pot	IA	

Trench 27

General description						Orientation		N-S
Trench revealed one ditch terminus running NE-SW. Trench consists of ploughsoil and subsoil overlying sandy clay and gravel natural.						Length (m)		30
						Width (m)		2
						Avg. depth (m)		0.54
Context No.	Type	Fill Of	Width (m)	Depth (m)	Description	Finds	Date	
2700	Layer			0.35	Ploughsoil. Dark greyish brown silty clay.			
2701	Layer			0.19	Subsoil. Light greyish brown silty clay.			
2702	Layer				Natural. Light orange brown silty clay and gravel.			
2703	Cut		0.52	0.19	Ditch			
2704	Fill	2703	0.32	0.1	Other Fill. Grey sandy clay gravel			
2705	Fill	2703	0.52	0.09	Secondary Fill. Brownish grey sandy clay			

Trench 28

General description						Orientation		E-W
Trench revealed one ditch. consists of ploughsoil and subsoil overlying natural geology of silty clay and gravel that has the appearance of being gleyed. Perhaps seasonally or for a time was waterlogged.						Length (m)		30
						Width (m)		2
						Avg. depth (m)		0.4
Context No.	Type	Fill Of	Width (m)	Depth (m)	Description	Finds	Date	
2800	Layer			0.24	Ploughsoil. Greyish brown, sandy silt			

2801	Layer			0.16	Subsoil. Light greyish brown, silty clay		
2802	Layer				Natural. Orangish grey, silty clay with frequent gravel inclusions		
2803	Cut		0.96	0.31	Ditch		
2804	Fill	2803	0.96	0.31	Primary Fill. Greyish brown, silty clay.		

Trench 29

General description	Orientation	N-S
Trench devoid of archaeology. Consisted of ploughsoil and subsoil overlying sandy gravel geology that has the appearance of being gleyed. Perhaps seasonally or for a time was waterlogged.	Length (m)	30
	Width (m)	2
	Avg. depth (m)	0.5

Context No.	Type	Fill Of	Width (m)	Depth (m)	Description	Finds	Date
2900	Layer			0.3	Ploughsoil. Dark grey clay silt.		
2901	Layer			0.2	Subsoil. Dark grey brown silty clay.		
2902	Layer				Natural. Grey sandy gravel. Possibly gleyed and manganese rich.		

Trench 30

General description	Orientation	E-W
Trench revealed two ditches. Consists of ploughsoil and subsoil overlying natural geology of sand and gravel that has the appearance of being gleyed. Perhaps seasonally or for a time was waterlogged.	Length (m)	30
	Width (m)	2
	Avg. depth (m)	0.39

Context No.	Type	Fill Of	Width (m)	Depth (m)	Description	Finds	Date
3000	Layer			0.23	Ploughsoil. Greyish brown, sandy silt		
3001	Layer			0.16	Subsoil. Light greyish brown, silty clay		
3002	Layer				Natural. Light orangish grey, sandy clay with frequent gravel pockets		
3003	Cut		1.1	0.16	Ditch		
3004	Fill	3003	1.1	0.16	Primary Fill. Firmly-compacted, greyish brown, silty clay with occasional charcoal flecks		
3005	Cut		0.68	0.14	Ditch		
3006	Fill	3005	0.68	0.14	Primary Fill. Firmly-compacted,		

					orangish grey, silty clay. Includes occasional small subangular stones.		
--	--	--	--	--	---	--	--

Trench 31							
General description					Orientation		E-W
Trench devoid of archaeology. Trench consists of ploughsoil overlying silty clay natural.					Length (m)		30
					Width (m)		2
					Avg. depth (m)		0.45
Context No.	Type	Fill Of	Width (m)	Depth (m)	Description	Finds	Date
3100	Layer		2	0.4	Ploughsoil. Dark greyish brown, sandy silt, loose, occasional round stones		
3101	Layer		2		Natural. Reddish brown, silty clay with frequent patches of rounded stones		
3102	Void						

Trench 32							
General description					Orientation		N-S
Trench revealed three pits. Trench consists of ploughsoil overlying clayey sand natural.					Length (m)		29
					Width (m)		2
					Avg. depth (m)		0.5
Context No.	Type	Fill Of	Width (m)	Depth (m)	Description	Finds	Date
3200	Layer			0.5	Ploughsoil. Brownish grey sandy silt with rare rounded gravels		
3201	Layer				Natural		
3202	Cut		0.84	0.31	Pit		
3203	Cut		1.29	0.2	Pit		
3204	Cut		0.62	0.19	Pit		
3205	Layer		0.32	0.12	Other Layer. Not drawn		
3206	Fill	3202	0.18	0.08	Secondary Fill. Grey brown, loose pebbles and clay silt		
3207	Fill	3202	0.43	0.21	Primary Fill. Light grey brown clay silt		

3208	Fill	3202	0.85	0.08	Secondary Fill. Very dark brown, clay silt	Glass bottles, CBM	late 19th or early 20th C
3209	Fill	3203	1.29	0.2	Primary Fill. Very dark brown, clay silt		
3210	Fill	3204	0.62	0.19	Primary Fill. Very dark brown, clay silt		

Trench 33

General description	Orientation	N-S
Trench devoid of archaeology. Trench consists of ploughsoil overlying silty clay natural.	Length (m)	30
	Width (m)	2
	Avg. depth (m)	0.4

Context No.	Type	Fill Of	Width (m)	Depth (m)	Description	Findings	Date
3300	Layer		2	0.4	Ploughsoil. Dark greyish brown, Sandy silt		
3301	Layer		2		Natural. Reddish brown clayey sand		

Trench 34

General description	Orientation	E-W
Trench revealed one ditch. Trench consists of ploughsoil overlying silty clay natural.	Length (m)	30
	Width (m)	2
	Avg. depth (m)	0.45

Context No.	Type	Fill Of	Width (m)	Depth (m)	Description	Findings	Date
3400	Layer		2	0.45	Ploughsoil. Dark greyish brown, sandy silt, loose, occasional rounded stones		
3401	Layer		2		Natural. Reddish brown, silty clay, frequent patches of rounded stones		
3402	Unexcavated feature		0.55		Ditch. Boundary ditch, filled by dark blackish grey silty sand with occasional rounded flint pebbles.		

Trench 35

General description	Orientation	N-S
Trench revealed two ditches. Trench consists of ploughsoil overlying gravelly sand natural.	Length (m)	30
	Width (m)	2

						Avg. depth (m)	0.4
Context No.	Type	Fill Of	Width (m)	Depth (m)	Description	Finds	Date
3500	Layer			0.4	Ploughsoil. Greyish brown silty sand with occasional rounded pebbles		
3501	Layer				Natural. Light brownish orange silty sand banded with dense patches of pebbles		
3502	Cut		0.81	0.17	Ditch		
3503	Fill	3502	0.81	0.17	Primary Fill. Pale grey brown, clay silt, firm	Pot	LBA-EIA
3504	Unexcavated feature		0.89		Natural Feature. Remnants of hedges small tree likely in plough furrow		
3505	Cut		0.53	0.1	Ditch		
3506	Fill	3505	0.53	0.1	Primary Fill. Grey brown silt clay, firm		

Trench 36

General description	Orientation	E-W
Trench devoid of archaeology. Trench consists of ploughsoil overlying silty clay natural.	Length (m)	30
	Width (m)	2
	Avg. depth (m)	0.4

Context No.	Type	Fill Of	Width (m)	Depth (m)	Description	Finds	Date
3600	Layer			0.4	Ploughsoil. Grey brown, sandy clay, friable		
3601	Layer				Natural. Orange brown, silty clay, compact		

Trench 37

General description	Orientation	N-S
Trench devoid of archaeology. Consists of ploughsoil overlying silty clay natural.	Length (m)	30
	Width (m)	2
	Avg. depth (m)	0.4

Context No.	Type	Fill Of	Width (m)	Depth (m)	Description	Finds	Date
3700	Layer			0.4	Ploughsoil. Grey brown, silty clay, friable		

3701	Layer				Natural. Orange brown, silty clay, friable		
Trench 38							
General description					Orientation	E-W	
Trench devoid of archaeology. Trench consists of ploughsoil overlying clayey sand natural.					Length (m)	30	
					Width (m)	2	
					Avg. depth (m)	0.34	
Context No.	Type	Fill Of	Width (m)	Depth (m)	Description	Finds	Date
3800	Layer			0.38	Ploughsoil. Grey brown, silty clay, friable		
3801	Layer				Natural. Orange brown, silty clay, compact		
Trench 39							
General description					Orientation	NE-SW	
Trench devoid of archaeology. Consists of ploughsoil overlying clayey sand natural.					Length (m)	30	
					Width (m)	2	
					Avg. depth (m)	0.4	
Context No.	Type	Fill Of	Width (m)	Depth (m)	Description	Finds	Date
3900	Layer			0.4	Ploughsoil. Greyish brown sandy silt with occasional sub-angular flint fragments.		
3901	Layer				Natural. Brownish yellow clayey sand and gravel with hematite and manganese inclusions.		
Trench 40							
General description					Orientation		
Not required					Length (m)		
					Width (m)		
					Avg. depth (m)		
Context No.	Type	Fill Of	Width (m)	Depth (m)	Description	Finds	Date
Trench 41							
General description					Orientation		
Not required					Length (m)		

						Width (m)	
						Avg. depth (m)	
Context No.	Type	Fill Of	Width (m)	Depth (m)	Description	Finds	Date
Trench 42							
General description						Orientation	NW-SE
Trench devoid of archaeology. Trench consists of ploughsoil and subsoil overlying sandy clay natural.						Length (m)	30
						Width (m)	2
						Avg. depth (m)	0.59
Context No.	Type	Fill Of	Width (m)	Depth (m)	Description	Finds	Date
4200	Layer			0.31	Ploughsoil. Grey brown, sandy clay, friable		
4201	Layer			0.25	Subsoil. Brown orange, sandy clay, friable		
4202	Layer				Natural. Brown yellow, sandy clay, friable		
Trench 43							
General description						Orientation	E-W
Trench devoid of archaeology. Trench consists of ploughsoil overlying sandy clay natural.						Length (m)	30
						Width (m)	2
						Avg. depth (m)	0.32
Context No.	Type	Fill Of	Width (m)	Depth (m)	Description	Finds	Date
4300	Layer			0.28	Ploughsoil. Greyish brown sandy silt with occasional sub-angular flint fragments and rounded pebbles.		
4301	Layer				Natural. Yellowish orange sandy clay with patches of gravel merging with reddish brown silty clay.		
Trench 44							
General description						Orientation	N-S
Trench devoid of archaeology. Trench consists of ploughsoil and subsoil overlying sandy clay natural.						Length (m)	30
						Width (m)	2
						Avg. depth (m)	0.4

Context No.	Type	Fill Of	Width (m)	Depth (m)	Description	Finds	Date
4400	Layer		2	0.4	Ploughsoil. Dark greyish brown, sandy silt, loose, occasional sub angular flint and rounded stones		
4401	Layer				Natural. Yellowish brown, clayey sand occasional reddish brown , silty clay patches with gravel		
4402	Void						

Trench 45

General description	Orientation	E-W
Trench devoid of archaeology. Trench consists of ploughsoil and subsoil overlying sandy clay natural.	Length (m)	30
	Width (m)	2
	Avg. depth (m)	0.4

Context No.	Type	Fill Of	Width (m)	Depth (m)	Description	Finds	Date
4500	Layer		2	0.4	Ploughsoil. Dark greyish brown, sandy silt, loose, occasional sub angular flint and sub angular and rounded stones		
4501	Layer				Natural. Yellowish brown Clayey sand frequent mid reddish brown patches with frequent rounded stones		
4502	Void						

Trench 46

General description	Orientation	N-S
Trench devoid of archaeology. Trench consists of ploughsoil overlying sandy clay natural.	Length (m)	30
	Width (m)	2
	Avg. depth (m)	0.4

Context No.	Type	Fill Of	Width (m)	Depth (m)	Description	Finds	Date
4600	Layer		2	0.4	Ploughsoil. Dark greyish brown, sandy silt, loose, occasional rounded stones		

4601	Layer		2		Natural. Yellowish brown, clayey sand with reddish brown silty clay patches with frequent rounded stones		
------	-------	--	---	--	--	--	--

Trench 47

General description	Orientation	E-W
Trench revealed one ditch and one posthole. Trench consists of ploughsoil overlying sandy gravel natural.	Length (m)	30
	Width (m)	2
	Avg. depth (m)	0.4

Context No.	Type	Fill Of	Width (m)	Depth (m)	Description	Finds	Date
4700	Layer			0.4	Ploughsoil. Grey brown, ploughsoil, occasional small subangular flints		
4701	Layer				Natural. Orange brown clay with occasional gravel bands		
4702	Cut		1.99	0.26	Ditch		
4703	Fill	4702	1.99	0.26	Primary Fill. Dark brown grey, silty clay, firm	Pot, CBM, AB	LIA or AD 1000-1150, Post-Med
4704	Cut		0.26	0.1	Posthole		
4705	Fill	4704	0.26	0.1	Primary Fill. Blue-grey, silty clay, moderately compact		

Trench 48

General description	Orientation	N-S
Trench devoid of archaeology consists of ploughsoil overlying sandy clay natural.	Length (m)	30
	Width (m)	2
	Avg. depth (m)	0.4

Context No.	Type	Fill Of	Width (m)	Depth (m)	Description	Finds	Date
4800	Layer		2	0.4	Ploughsoil. Dark greyish brown, sandy silt, loose, occasional rounded stones		
4801	Layer		2		Natural. Reddish brown, sandy clay with occasional patches of rounded stones		

Trench 49							
General description					Orientation		E-W
Trench contains one linear and a field drain. Trench consists of ploughsoil overlying clayey sand natural.					Length (m)		30
					Width (m)		2
					Avg. depth (m)		0.48
Context No.	Type	Fill Of	Width (m)	Depth (m)	Description	Finds	Date
4900	Layer			0.4	Ploughsoil. Greyish brown sandy silt with occasional sub-angular flint fragments and rounded pebbles.		
4901	Layer				Natural. Yellowish orange and brown clayey sand with occasional rounded pebbles.		
4902	Layer				Subsoil. light grey brown silty clay	Pot	AD 43-70
4903	Cut		0.75	0.2	Ditch		
4904	Fill	4903	0.75	0.2	Primary Fill. light grey brown, silty clay, friable	Pot, <S3>	?? AD 1050-1150

Trench 50

General description					Orientation		N-S
Trench devoid of archaeology. Trench consists of ploughsoil overlying sandy clay natural with gravels.					Length (m)		30
					Width (m)		2
					Avg. depth (m)		0.4
Context No.	Type	Fill Of	Width (m)	Depth (m)	Description	Finds	Date
5000	Layer			0.3	Ploughsoil. Greyish brown sandy silt with occasional sub-angular flint fragments and rounded pebbles.		
5001	Layer				Natural. Yellowish orange sandy clay with patches of gravel merging with reddish brown silty clay.		

Trench 51

General description					Orientation		E-W
---------------------	--	--	--	--	-------------	--	-----

Trench revealed one ditch. Trench consists of ploughsoil and subsoil overlying sandy clay natural.						Length (m)	30
						Width (m)	2
						Avg. depth (m)	0.67
Context No.	Type	Fill Of	Width (m)	Depth (m)	Description	Finds	Date
5100	Layer			0.35	Ploughsoil. Grey brown, sandy clay, friable		
5101	Layer			0.17	Subsoil. Orange brown, sandy clay, friable		
5102	Layer				Natural. Brown yellow, sandy clay with gravel, friable		
5103	Cut		0.34	0.2	Ditch		
5104	Fill	5103	0.34	0.2	Secondary Fill. Light orange grey, sandy silt		
Trench 52							
General description						Orientation	N-S
Trench devoid of archaeology. Trench consists of ploughsoil and subsoil overlying sandy clay natural.						Length (m)	30
						Width (m)	2
						Avg. depth (m)	0.54
Context No.	Type	Fill Of	Width (m)	Depth (m)	Description	Finds	Date
5200	Layer			0.32	Ploughsoil. Grey brown, sandy clay, friable		
5201	Layer			0.14	Subsoil. Orange brown, sandy clay, friable		
5202	Layer				Natural. Brown yellow, sandy clay with gravel, friable		
5203	Void						
Trench 53							
General description						Orientation	E-W
Trench devoid of archaeology. Trench consists of ploughsoil overlying sandy clay natural.						Length (m)	30
						Width (m)	2
						Avg. depth (m)	0.38
Context No.	Type	Fill Of	Width (m)	Depth (m)	Description	Finds	Date
5300	Layer			0.38	Ploughsoil. Greyish brown sandy silt with occasional sub-angular flint fragments and rounded pebbles.		
5301	Layer				Natural. Yellowish orange sandy clay		

					with patches of gravel merging with reddish brown silty clay.		
Trench 54							
General description					Orientation		N-S
Trench devoid of archaeology. Trench consists of ploughsoil and subsoil overlying sandy clay natural.					Length (m)		30
					Width (m)		2
					Avg. depth (m)		0.4
Context No.	Type	Fill Of	Width (m)	Depth (m)	Description	Finds	Date
5400	Layer		2	0.4	Ploughsoil. Dark greyish brown, sandy silt, loose, occasional rounded and sub angular stones		
5401	Layer				Natural. Yellowish brown clayey sand occasional mid reddish brown silty clay patches with frequent rounded stones		
5402	Void						
Trench 55							
General description					Orientation		E-W
Trench devoid of archaeology. Trench consists of ploughsoil overlying sandy clay natural.					Length (m)		30
					Width (m)		2
					Avg. depth (m)		0.4
Context No.	Type	Fill Of	Width (m)	Depth (m)	Description	Finds	Date
5500	Layer		2	0.4	Ploughsoil. Dark greyish brown. Sandy silt, loose, occasional rounded stones		
5501	Layer		2		Natural. Reddish brown, sandy clay, occasional rounded stones		
Trench 56							
General description					Orientation		N-S
Trench devoid of archaeology. Trench consists of ploughsoil overlying clayey sand natural.					Length (m)		30
					Width (m)		2
					Avg. depth (m)		0.39
Context No.	Type	Fill Of	Width (m)	Depth (m)	Description	Finds	Date

5600	Layer			0.39	Ploughsoil. Greyish brown sandy silt with occasional sub-angular flint fragments and rounded pebbles.		
5601	Layer				Natural. Yellowish orange sandy clay with occasional rounded pebbles.		

Trench 57

General description	Orientation	E-W
Trench devoid of archaeology. Trench consists of ploughsoil overlying clayey sand natural.	Length (m)	30
	Width (m)	2
	Avg. depth (m)	0.4

Context No.	Type	Fill Of	Width (m)	Depth (m)	Description	Finds	Date
5700	Layer			0.4	Ploughsoil. Greyish brown sandy silt with occasional sub-angular flint fragments and rounded pebbles.		
5701	Layer				Natural. Light yellowish brown and orange clayey sand		

Trench 58

General description	Orientation	N-S
Trench devoid of archaeology. Trench consists of ploughsoil overlying clayey sand natural.	Length (m)	30
	Width (m)	2
	Avg. depth (m)	0.44

Context No.	Type	Fill Of	Width (m)	Depth (m)	Description	Finds	Date
5800	Layer			0.41	Ploughsoil. Greyish brown sandy silt with occasional sub-angular flint fragments and rounded pebbles.		
5801	Layer				Natural. Light yellowish brown and orange clayey sand		

Trench 59

General description	Orientation	N-S
Trench devoid of archaeology. Trench consists of ploughsoil overlying sandy clay natural.	Length (m)	30
	Width (m)	2
	Avg. depth (m)	0.35

Context No.	Type	Fill Of	Width (m)	Depth (m)	Description	Finds	Date
5900	Layer			0.35	Ploughsoil. Grey brown sandy silt with occasional sub-angular flint fragments and rounded pebbles.		
5901	Layer				Natural. Yellowish orange sandy clay with patches of gravel merging with reddish brown silty clay.		

Trench 60

General description	Orientation	E-W
Trench devoid of archaeology. Trench consists of ploughsoil overlying sandy clay natural.	Length (m)	30
	Width (m)	2
	Avg. depth (m)	0.4

Context No.	Type	Fill Of	Width (m)	Depth (m)	Description	Finds	Date
6000	Layer			0.3	Ploughsoil. Greyish brown sandy silt with occasional sub-angular flint fragments and rounded pebbles.		
6001	Layer				Natural. Yellowish orange sandy clay with patches of gravel merging with reddish brown silty clay.		

Trench 61

General description	Orientation	N-S
Trench devoid of archaeology. Trench consists of ploughsoil overlying sandy clay natural.	Length (m)	30
	Width (m)	2
	Avg. depth (m)	0.41

Context No.	Type	Fill Of	Width (m)	Depth (m)	Description	Finds	Date
6100	Layer			0.3	Ploughsoil. Greyish brown sandy silt with occasional sub-angular flint fragments and rounded pebbles.		
6101	Layer				Natural. Yellowish orange sandy clay with patches of gravel merging with reddish brown silty clay.		

Trench 62							
General description					Orientation		E-W
Trench devoid archaeology. Trench consists of ploughsoil overlying sandy clay natural.					Length (m)		30
					Width (m)		2
					Avg. depth (m)		0.4
Context No.	Type	Fill Of	Width (m)	Depth (m)	Description	Finds	Date
6200	Layer			0.4	Ploughsoil. Greyish brown sandy silt with occasional sub-angular flint fragments and rounded pebbles.		
6201	Layer				Natural. Yellowish orange sandy clay with patches of gravel merging with reddish brown silty clay.		
Trench 63							
General description					Orientation		N-S
Trench devoid of archaeology. Trench consists of ploughsoil overlying clayey sand natural.					Length (m)		30
					Width (m)		2
					Avg. depth (m)		0.4
Context No.	Type	Fill Of	Width (m)	Depth (m)	Description	Finds	Date
6300	Layer			0.4	Ploughsoil. Greyish brown sandy silt with occasional sub-angular flint fragments and rounded pebbles.		
6301	Layer				Natural. Reddish orange sandy clay with patches of gravel.		
Trench 64							
General description					Orientation		E-W
Trench devoid of archaeology. Trench consists of ploughsoil overlying sandy clay natural.					Length (m)		30
					Width (m)		2
					Avg. depth (m)		0.39
Context No.	Type	Fill Of	Width (m)	Depth (m)	Description	Finds	Date
6400	Layer			0.39	Ploughsoil. Greyish brown sandy silt with occasional sub-angular flint fragments and rounded pebbles.		

6401	Layer				Natural. Reddish orange sandy clay with rare rounded pebbles.		
Trench 65							
General description					Orientation	N-S	
Trench devoid of archaeology. Trench consists of ploughsoil overlying sandy clay natural.					Length (m)	30	
					Width (m)	2	
					Avg. depth (m)	0.4	
Context No.	Type	Fill Of	Width (m)	Depth (m)	Description	Finds	Date
6500	Layer			0.4	Ploughsoil. Greyish brown sandy silt with occasional sub-angular flint fragments and rounded pebbles.		
6501	Layer				Natural. Yellowish orange sandy clay with		
Trench 66							
General description					Orientation	E-W	
Trench contains a modern feature and a ditch. Trench consists of ploughsoil overlying clayey sand natural.					Length (m)	30	
					Width (m)	2	
					Avg. depth (m)	0.4	
Context No.	Type	Fill Of	Width (m)	Depth (m)	Description	Finds	Date
6600	Layer			0.34	Ploughsoil. Greyish brown sandy silt with occasional sub-angular flint fragments and rounded pebbles.		
6601	Layer				Natural. Yellowish orange clayey sand with occasional patches of gravel and reddish orange clay.		
6602	Cut		0.8	0.5	Modern. Pipe		
6603	Void						
6604	Unexcavated feature				Ditch. PM field boundary		
Trench 67							
General description					Orientation	N-S	
Trench devoid of archaeology. Trench consists of ploughsoil overlying gravelly sand natural.					Length (m)	30	
					Width (m)	2	

						Avg. depth (m)	0.45
Context No.	Type	Fill Of	Width (m)	Depth (m)	Description	Finds	Date
6700	Layer			0.35	Ploughsoil. Greyish brown sandy silt with occasional sub-angular flint fragments and rounded pebbles.		
6701	Layer				Natural. Light yellowish brown and orange clayey sand frequent gravel		
Trench 68							
General description						Orientation	E-W
Trench revealed possible brick kiln. Trench consists of ploughsoil overlying clayey sand natural.						Length (m)	30
						Width (m)	2
						Avg. depth (m)	0.4
Context No.	Type	Fill Of	Width (m)	Depth (m)	Description	Finds	Date
6800	Layer		2	0.38	Ploughsoil. Dark greyish brown, sandy silt, occasional rounded and sub angular stones		
6801	Layer		2		Natural. Light greyish brown, sandy silt, compact, occasional rounded and sub angular stones		
6802	Fill	6808	1.42	0.25	Other Fill. Dark grey brown, clayey sand, moderately compact	CBM, Pot	C15th-16th, pot 1805-1900
6803	Layer		0.96	0.06	Other Layer. Red brown, sandy clay, moderately compact.	CBM, <S2>	C15th-16th
6804	Cut		0.44	0.36	Posthole		
6805	Fill	6804	0.44	0.36	Secondary Fill. Grey brown, clayey sand, moderately compact		
6806	Layer			0.04	Occupation Layer. Grey brown, clayey sand, moderately compact		
6807	Fill	6808	0.78	0.1	Deliberate Backfill. Yellow brown, silty clay, moderately compact.		

6808	Cut		1.44	0.24	Other Cut. Cut for possible kiln or brick structure		
------	-----	--	------	------	---	--	--

Trench 69

General description	Orientation	N-S
Trench devoid of archaeology. Trench consists of ploughsoil overlying clayey sand natural.	Length (m)	30
	Width (m)	2
	Avg. depth (m)	0.47

Context No.	Type	Fill Of	Width (m)	Depth (m)	Description	Finds	Date
6900	Layer			0.4	Ploughsoil. Greyish brown sandy silt with occasional sub-angular flint fragments and rounded pebbles.		
6901	Layer				Natural. Yellowish orange clayey sand with occasional pebbles.		

Trench 70

General description	Orientation	E-W
Trench devoid of archaeology. Trench consists of ploughsoil overlying clayey sand natural.	Length (m)	30
	Width (m)	2
	Avg. depth (m)	0.43

Context No.	Type	Fill Of	Width (m)	Depth (m)	Description	Finds	Date
7000	Layer			0.34	Ploughsoil. Greyish brown sandy silt with occasional sub-angular flint fragments and rounded pebbles.		
7001	Layer				Natural. Yellowish orange clayey sand.		

Trench 71

General description	Orientation	N-S
Trench devoid of archaeology. Trench consists of ploughsoil overlying clayey sand natural.	Length (m)	30
	Width (m)	2
	Avg. depth (m)	0.4

Context No.	Type	Fill Of	Width (m)	Depth (m)	Description	Finds	Date
7100	Layer			0.4	Ploughsoil. Greyish brown sandy silt with occasional sub-angular flint		

					fragments and rounded pebbles.		
7101	Layer				Natural. Yellowish orange sandy clay with patches of gravel merging with reddish brown silty clay.		
Trench 72							
General description					Orientation		E-W
Trench revealed one pit and two postholes. Trench consists of ploughsoil overlying sandy gravel natural.					Length (m)		30
					Width (m)		2
					Avg. depth (m)		0.4
Context No.	Type	Fill Of	Width (m)	Depth (m)	Description	Finds	Date
7200	Layer			0.42	Ploughsoil. Greyish brown sandy clay.		
7201	Layer				Natural. Reddish brown clayey sand.		
7202	Cut		0.6	0.12	Pit		
7203	Fill	7202	0.6	0.12	Primary Fill. Red grey, silty sand, loose.	Fired Clay, Pot, <S1>	LBA-EIA
7204	Cut		0.2	0.09	Pit		
7205	Fill	7204	0.2	0.09	Primary Fill. Brown grey, silty sand, loose		
7206	Cut		0.22	0.06	Pit		
7207	Fill	7206	0.22	0.06	Primary Fill. Grey-brown, silty sand, loosely-compacted, occasional fine charcoal flecks		
Trench 73							
General description					Orientation		N-S
Trench devoid of archaeology. Trench consists of ploughsoil overlying clayey sand natural.					Length (m)		30
					Width (m)		1.8
					Avg. depth (m)		0.36
Context No.	Type	Fill Of	Width (m)	Depth (m)	Description	Finds	Date
7300	Layer			0.36	Ploughsoil. Greyish brown sandy silt with occasional sub-angular flint fragments and rounded pebbles.		
7301	Layer				Natural. Yellowish clayey sand with reddish orange bands of sandy clay.		

Trench 74							
General description					Orientation		N-S
Trench devoid of archaeology. Trench consists of ploughsoil overlying clayey sand natural.					Length (m)		30
					Width (m)		1.8
					Avg. depth (m)		0.43
Context No.	Type	Fill Of	Width (m)	Depth (m)	Description	Finds	Date
7400	Layer			0.43	Ploughsoil. Greyish brown sandy silt with occasional sub-angular flint fragments and rounded pebbles.		
7401	Layer				Natural. Yellowish orange clayey sand with hematite and manganese inclusions.		
Trench 75							
General description					Orientation		E-W
Trench devoid of archaeology. Trench consists of ploughsoil overlying clayey sand natural.					Length (m)		30
					Width (m)		2
					Avg. depth (m)		0.39
Context No.	Type	Fill Of	Width (m)	Depth (m)	Description	Finds	Date
7500	Layer			0.39	Ploughsoil. Greyish brown sandy silt with occasional sub-angular flint fragments and rounded pebbles.		
7501	Layer				Natural. Yellowish orange clayey sand with hematite and manganese inclusions.		
Trench 76							
General description					Orientation		E-W
Trench devoid of archaeology. Trench consists of ploughsoil overlying gravelly sand natural.					Length (m)		30
					Width (m)		2
					Avg. depth (m)		0.49
Context No.	Type	Fill Of	Width (m)	Depth (m)	Description	Finds	Date
7600	Layer			0.49	Ploughsoil. Greyish brown sandy silt with occasional sub-angular flint fragments and rounded pebbles.		

7601	Layer				Natural. Yellowish orange clayey sand with manganese inclusions and patches of gravel.		
Trench 77							
General description					Orientation	N-S	
Trench contains one large charcoal spread and some dump deposits all intercut into the subsoil. Trench consists of ploughsoil overlying gravelly sandy subsoil.					Length (m)	30	
					Width (m)	2	
					Avg. depth (m)	0.4	
Context No.	Type	Fill Of	Width (m)	Depth (m)	Description	Finds	Date
7700	Layer			0.35	Ploughsoil. Greyish brown silty sand with occasional rounded pebbles.		
7701	Layer				Natural. Light brownish yellow clayey sand.		
7702	Cut		0.28	0.28	Ditch		
7703	Fill	7702	0.28	0.28	Deliberate Backfill. Dark grey sandy silt, soft.	CBM	C15th-16th
7704	Layer		7	0.13	Occupation Layer. dark grey sandy silt, soft	CBM	C15th-16th
7705	Layer		2.1	0.17	Subsoil. Brown red, silty sand, friable		
7706	Layer		2.1	0.13	Subsoil. Yellow grey brown, silty clay, friable		
7707	Layer		2.1	0.17	Other Layer. Orange yellow, silty clay, firm	CBM	C15th-16th
7708	Cut		0.73	0.3	Ditch. Cuts subsoil. E-W		
7709	Fill	7708	0.73	0.3	Secondary Fill. Yellowish brown natural backfill		
7710	Cut		0.25	0.31	Modern. NW-SE Probably land drain		
7711	Fill	7710	0.25	0.31	Secondary Fill. Brownish orange natural backfill		
Trench 78							
General description					Orientation	E-W	
Trench devoid of archaeology. Trench consists of ploughsoil overlying clayey sand natural.					Length (m)	30	
					Width (m)	2	
					Avg. depth (m)	0.48	
Context No.	Type	Fill Of	Width (m)	Depth (m)	Description	Finds	Date
7800	Layer			0.44	Ploughsoil. Greyish brown sandy silt with		

					occasional sub-angular flint fragments and rounded pebbles.		
7801	Layer				Natural. Yellowish orange clayey sand with rare rounded pebbles.		
Trench 79							
General description					Orientation		N-S
Trench devoid of archaeology. Trench consists of ploughsoil overlying clayey sand natural.					Length (m)		30
					Width (m)		2
					Avg. depth (m)		0.48
Context No.	Type	Fill Of	Width (m)	Depth (m)	Description	Finds	Date
7900	Layer			0.4	Ploughsoil. Greyish brown sandy silt with occasional sub-angular flint fragments and rounded pebbles		
7901	Layer				Natural. Yellowish orange clayey sand		
Trench 80							
General description					Orientation		E-W
Trench devoid of archaeology. Trench consists of ploughsoil overlying clayey sand natural.					Length (m)		30
					Width (m)		2
					Avg. depth (m)		0.36
Context No.	Type	Fill Of	Width (m)	Depth (m)	Description	Finds	Date
8000	Layer			0.36	Ploughsoil. Greyish brown sandy silt with occasional sub-angular flint fragments and rounded pebbles.		
8001	Layer				Natural. Yellowish orange clayey sand		
Trench 81							
General description					Orientation		N-S
Trench devoid of archaeology. Trench consists of ploughsoil overlying clayey sand natural.					Length (m)		30
					Width (m)		2
					Avg. depth (m)		0.36
Context No.	Type	Fill Of	Width (m)	Depth (m)	Description	Finds	Date
8100	Layer		2	0.35	Ploughsoil. Dark brown, sandy silt, loose, occasional rounded stones		

8101	Layer		2		Natural. Reddish brown, silty clay, occasional rounded stones and light yellowish brown sandy patches		
Trench 82							
General description					Orientation		E-W
Trench devoid of archaeology. Trench consists of ploughsoil overlying sandy clay natural.					Length (m)		30
					Width (m)		2
					Avg. depth (m)		0.35
Context No.	Type	Fill Of	Width (m)	Depth (m)	Description	Finds	Date
8200	Layer		2	0.35	Ploughsoil. Dark greyish brown, sandy silt, loose, occasional rounded stones		
8201	Layer		2		Natural. Reddish brown, sandy clay, occasional rounded stones		
Trench 83							
General description					Orientation		N-S
Trench devoid of archaeology. Trench consists of ploughsoil overlying sandy clay natural.					Length (m)		30
					Width (m)		2
					Avg. depth (m)		0.4
Context No.	Type	Fill Of	Width (m)	Depth (m)	Description	Finds	Date
8300	Layer		2	0.4	Ploughsoil. Dark greyish brown, sandy silt, occasional rounded stones		
8301	Layer		2		Natural. Reddish brown, sandy clay, occasional rounded stones		
Trench 84							
General description					Orientation		E-W
Trench revealed one ditch. Trench consists of ploughsoil overlying clayey sand natural.					Length (m)		30
					Width (m)		2
					Avg. depth (m)		0.4
Context No.	Type	Fill Of	Width (m)	Depth (m)	Description	Finds	Date
8400	Layer			0.42	Ploughsoil. Light grey-brown, frequent subrounded stones		

8401	Layer				Natural. Light orange-yellow sand with occasional gravel and clay bands		
8402	Cut		1.48	0.51	Ditch		
8403	Fill	8402	1.48	0.51	Primary Fill. Light brown grey, clay silt, moderately compact	Glass bottle, CBM	C19th

Trench 85

General description	Orientation	N-S
Trench revealed two pits. Trench consists of ploughsoil overlying clayey sand natural.	Length (m)	30
	Width (m)	2
	Avg. depth (m)	0.4

Context No.	Type	Fill Of	Width (m)	Depth (m)	Description	Finds	Date
8500	Layer			0.4	Ploughsoil. Very dark greyish brown, clay silt		
8501	Layer				Natural. Yellow brown clayey sand		
8502	Layer		0.54	0.06	Other layer. remnants of charcoal deposit, no cut visible		
8503	Cut		0.83	0.08	Natural Feature. Greyish brown, silty sand with small and medium stones		
8504	Cut		0.8	0.24	Pit		
8505	Fill	8504	0.34	0.06	Primary Fill. Light brownish orange silty sand, soft with small stones		
8506	Fill	8504	0.24	0.06	Secondary Fill. Orangeish/light brown, Sand		
8507	Fill	8504	0.8	0.18	Secondary Fill. Soft light yellowish brown sand with charcoal inclusions		

Trench 86

General description	Orientation	N-S
Trench contains one ditch. Consists of ploughsoil and subsoil overlying clayey sand natural.	Length (m)	30
	Width (m)	1.8
	Avg. depth (m)	0.45

Context No.	Type	Fill Of	Width (m)	Depth (m)	Description	Finds	Date
8600	Layer			0.39	Ploughsoil. Dark grey brown, sandy silt, soft		

8601	Layer			0.22	Subsoil. Yellow brown, clayey sand, soft		
8602	Layer				Natural. Light grey yellow, clayey sand, firm		
8603	Cut		1.2	0.34	Ditch		
8604	Fill	8603	1.2	0.34	Deliberate Backfill. Orange brown, clayey sand, soft		

Trench 87

General description					Orientation	N-S	
Trench devoid of archaeology. Trench consists of ploughsoil overlying clayey sand natural.					Length (m)	30	
					Width (m)	1.8	
					Avg. depth (m)	0.46	
Context No.	Type	Fill Of	Width (m)	Depth (m)	Description	Finds	Date
8700	Layer			0.4	Ploughsoil. Greyish brown sandy silt with occasional sub-angular flint fragments and rounded pebbles.		
8701	Layer				Natural. Yellowish orange clayey sand with manganese inclusion.		

Trench 88

General description					Orientation	N-S	
Trench devoid of archaeology. Trench consists of ploughsoil overlying clayey sand natural.					Length (m)	30	
					Width (m)	1.8	
					Avg. depth (m)	0.45	
Context No.	Type	Fill Of	Width (m)	Depth (m)	Description	Finds	Date
8800	Layer			0.4	Ploughsoil. Greyish brown sandy silt with rare sub-angular flint fragments and rounded pebbles.		
8801	Layer				Natural. Yellowish orange clayey sand		

Trench 89

General description					Orientation	E-W	
Trench devoid of archaeology. Trench consists of ploughsoil overlying clayey sand natural.					Length (m)	30	
					Width (m)	2	
					Avg. depth (m)	0.4	
Context No.	Type	Fill Of	Width (m)	Depth (m)	Description	Finds	Date

8900	Layer		2	0.3	Ploughsoil. Dark greyish brown, sandy silt, loose, occasional rounded stones		
8901	Layer		2		Natural. Yellowish brown sandy silt.		
Trench 90							
General description					Orientation		N-S
Trench devoid of archaeology. Trench consists of ploughsoil overlying clayey sand natural.					Length (m)		30
					Width (m)		2
					Avg. depth (m)		0.4
Context No.	Type	Fill Of	Width (m)	Depth (m)	Description	Finds	Date
9000	Layer		2	0.4	Ploughsoil. Dark greyish brown, sandy silt, loose, occasional rounded stones		
9001	Layer		2		Natural. Reddish brown sandy clay, occasional rounded stones and sandy light yellowish brown patches		
Trench 91							
General description					Orientation		E-W
Trench devoid of archaeology. consists of ploughsoil overlying clayey sand natural.					Length (m)		30
					Width (m)		2
					Avg. depth (m)		0.4
Context No.	Type	Fill Of	Width (m)	Depth (m)	Description	Finds	Date
9100	Layer		2	0.4	Ploughsoil. Dark greyish brown, sandy silt, occasional rounded stones		
9101	Layer		2		Natural. Reddish brown, clayey sand with occasional rounded stones and frequent light yellowish brown sand patches		
9102	Cut	9102	2	0.35	Natural Feature. geological layer or likely tree throw - mottled very dark brown silt clay with red yellow clay sand		
Trench 92							

General description						Orientation	N-S
Trench devoid of archaeology. Trench consists of ploughsoil overlying clayey sand natural.						Length (m)	30
						Width (m)	1.8
						Avg. depth (m)	0.43
Context No.	Type	Fill Of	Width (m)	Depth (m)	Description	Finds	Date
9200	Layer			0.43	Ploughsoil. Greyish brown sandy silt with occasional sub-angular flint fragments and rounded pebbles.		
9201	Layer				Natural. Reddish orange sandy clay with occasional patches of gravel.		
Trench 93							
General description						Orientation	E-W
Trench devoid of archaeology. Trench consists of ploughsoil overlying clayey sand natural.						Length (m)	30
						Width (m)	2
						Avg. depth (m)	0.4
Context No.	Type	Fill Of	Width (m)	Depth (m)	Description	Finds	Date
9300	Layer		2	0.4	Ploughsoil. Dark greyish brown. Sandy silt, occasional rounded stones		
9301	Layer		2		Natural. Reddish brown, clayey sand, frequent patches of rounded stones		
Trench 94							
General description						Orientation	E-W
Trench devoid of archaeology. Trench consists of ploughsoil overlying clayey sand natural.						Length (m)	30
						Width (m)	2
						Avg. depth (m)	0.4
Context No.	Type	Fill Of	Width (m)	Depth (m)	Description	Finds	Date
9400	Layer		2	0.4	Ploughsoil. Greyish Brown, sandy silt, loose, occasional rounded stones		
9401	Layer		2		Natural. Yellowish brown, clayey sand occasional rounded stones		
Trench 95							

General description						Orientation	N-S
Trench devoid of archaeology. Trench consists of ploughsoil overlying clayey sand natural.						Length (m)	30
						Width (m)	2
						Avg. depth (m)	0.4
Context No.	Type	Fill Of	Width (m)	Depth (m)	Description	Finds	Date
9500	Layer		2	0.4	Ploughsoil. Greyish brown, sandy silt, occasional rounded stones		
9501	Layer		2		Natural. Yellowish brown sandy clay with rare rounded stones and frequent fine manganese		
Trench 96							
General description						Orientation	E-W
Trench devoid of archaeology. Trench consists of ploughsoil overlying clayey sand natural.						Length (m)	30
						Width (m)	2
						Avg. depth (m)	0.47
Context No.	Type	Fill Of	Width (m)	Depth (m)	Description	Finds	Date
9600	Layer			0.4	Ploughsoil. Greyish brown sandy silt with occasional sub-angular flint fragments and rounded pebbles.		
9601	Layer				Natural. Yellowish orange clayey sand with manganese inclusion.		
Trench 97							
General description						Orientation	N-S
Trench devoid of archaeology. Trench consists of ploughsoil overlying clayey sand natural.						Length (m)	30
						Width (m)	2
						Avg. depth (m)	0.4
Context No.	Type	Fill Of	Width (m)	Depth (m)	Description	Finds	Date
9700	Layer		2	0.4	Ploughsoil. Dark greyish brown, sandy silt, loose, occasional rounded stones		
9701	Layer		2		Natural. Yellowish brown, sandy clay, occasional rounded stones		
Trench 98							

General description						Orientation	E-W
Trench devoid of archaeology. Trench consists of ploughsoil and subsoil overlying clayey sand natural.						Length (m)	30
						Width (m)	2
						Avg. depth (m)	0.45
Context No.	Type	Fill Of	Width (m)	Depth (m)	Description	Finds	Date
9800	Layer		2	0.28	Ploughsoil. Dark brown, sandy silt, occasional rounded stones		
9801	Layer		2	0.17	Subsoil. Greyish brown sandy silt, loose, frequent rounded stones		
9802	Layer		2		Natural. Light yellowish brown sandy silt with reddish sandy clay patches with frequent rounded stones		
Trench 99							
General description						Orientation	N-S
Trench devoid of archaeology. Trench consists of ploughsoil and subsoil overlying clayey sand natural.						Length (m)	30
						Width (m)	2
						Avg. depth (m)	0.44
Context No.	Type	Fill Of	Width (m)	Depth (m)	Description	Finds	Date
9900	Layer		2	0.35	Ploughsoil. Dark greyish brown, sandy silt, occasional rounded stones		
9901	Layer		2	0.05	Subsoil. Greyish brown, clayey sand, frequent rounded stones		
9902	Layer		2		Natural. Yellowish brown, clayey silt, frequent patches of rounded stones		
Trench 100							
General description						Orientation	E-W
Trench revealed one ditch. Trench consists of ploughsoil overlying a sandy clay natural.						Length (m)	30
						Width (m)	2
						Avg. depth (m)	0.4
Context No.	Type	Fill Of	Width (m)	Depth (m)	Description	Finds	Date
10000	Layer		2	0.4	Ploughsoil. Dark greyish brown.		

					Sandy silt, occasional rounded stones		
10001	Layer		2		Natural. Reddish brown, sandy clay, occasional rounded stones		
10002	Cut		1.32	0.35	Ditch. Shallow ditch. Irregular flat base/gradual straight sides and top		
10003	Fill	10002	1.32	0.35	Primary Fill. Grey brown, clay silt common rounded stone		

Trench 101							
General description					Orientation		N-S
Trench devoid of archaeology. Trench consists of ploughsoil overlying sandy clay natural.					Length (m)		30
					Width (m)		2
					Avg. depth (m)		0.4
Context No.	Type	Fill Of	Width (m)	Depth (m)	Description	Finds	Date
10100	Layer		2	0.4	Ploughsoil. Dark greyish brown. Sandy silt, occasional rounded stones		
10101	Layer		2		Natural. Reddish brown, Sandy clay, occasional rounded stones		
Trench 102							
General description					Orientation		E-W
Trench devoid of archaeology. Trench consists of ploughsoil overlying clayey sand natural.					Length (m)		30
					Width (m)		2
					Avg. depth (m)		0.4
Context No.	Type	Fill Of	Width (m)	Depth (m)	Description	Finds	Date
10200	Layer		2	0.4	Ploughsoil. Greyish brown, sandy silt, occasional rounded stones		
10201	Layer		2		Natural. Reddish brown, clayey silt, occasional rounded stones		
Trench 103							
General description					Orientation		
Not required					Length (m)		

						Width (m)	
						Avg. depth (m)	
Context No.	Type	Fill Of	Width (m)	Depth (m)	Description	Finds	Date
Trench 104							
General description						Orientation	N-S
Trench contains one ditch. Trench consists of ploughsoil overlying clayey sand natural.						Length (m)	30
						Width (m)	2
						Avg. depth (m)	0.5
Context No.	Type	Fill Of	Width (m)	Depth (m)	Description	Finds	Date
10400	Layer		2		Ploughsoil. Dark greyish brown sandy silt.		
10401	Layer		2		Natural. Reddish brown gravelly sand.		
10402	Cut		0.6	0.28	Ditch		
10403	Fill	10402	0.6	0.28	Primary Fill. Soft Yellowish/orange sandy silt	LBA-EIA Pot, Nail ?, CBM	? Post-med
Trench 105							
General description						Orientation	E-W
Trench consists of plough soil and subsoil overlying natural clayey sand						Length (m)	30
						Width (m)	2
						Avg. depth (m)	0.5
Context No.	Type	Fill Of	Width (m)	Depth (m)	Description	Finds	Date
10500	Layer		2	0.3	Ploughsoil. Greyish brown sandy silt occasional rounded stones		
10501	Layer		2	0.1	Subsoil. Greyish born, clayey silt frequent rounded stones		
10502	Layer		2		Natural. Yellowish brown, clayey silt, occasional rounded stones		
Trench 106							
General description						Orientation	E-W
Trench devoid of archaeology. Trench consists of ploughsoil overlying clayey sand natural.						Length (m)	30
						Width (m)	2
						Avg. depth (m)	0.45
Context No.	Type	Fill Of	Width (m)	Depth (m)	Description	Finds	Date

10600	Layer		2	0.45	Ploughsoil. Dark greyish brown, sandy silt, occasional rounded stones		
10601	Layer		2		Natural. Reddish brown, clayey sand, frequent sub angular and rounded stones		
Trench 107							
General description					Orientation		E-W
Trench revealed 5 ditches and one spread. Consists of ploughsoil overlying sandy gravel natural.					Length (m)		30
					Width (m)		2
					Avg. depth (m)		0.5
Context No.	Type	Fill Of	Width (m)	Depth (m)	Description	Finds	Date
10700	Layer			0.42	Ploughsoil. Greyish brown, sandy silt, frequent small sub-rounded stones		
10701	Layer				Natural. Light orange/yellow, sand, frequent small sub-rounded and subangular stones		
10702	Cut		1.06	0.08	Ditch		
10703	Fill	10702	1.06	0.08	Primary Fill. Dark greyish brown, sandy silt, frequent small subangular stones, occasional charcoal flecks	CBM	Post-med
10704	Cut		2.08	0.69	Ditch		
10705	Fill	10704	1.2	0.2	Primary Fill. Light brownish grey, sandy silt, frequent small-medium subangular stones		
10706	Fill	10704	1.9	0.25	Secondary Fill. Grey brown, silty sand, fragmented flint inclusions		
10707	Fill	10704	1.7	0.33	Secondary Fill. Dark grey brown, silty sand, friable	CBM	C19th
10708	Cut		2.28	0.33	Ditch		
10709	Fill	10708	2.28	0.33	Primary Fill. Light brownish grey silty sand, friable		
10710	Cut		0.96	0.27	Ditch		
10711	Fill	10710	0.96	0.27	Secondary Fill. Dark grey brown, silty sand, friable		

					small stone inclusions		
10712	Cut		1.15	0.49	Ditch		
10713	Fill	10712	1	0.34	Secondary Fill. Light bluish grey, silty sand, friable		
10714	Fill		1.15	0.18	Secondary Fill. Light yellowish brown, silty sand, friable		
10715	Cut		2.6	1.2	Ditch		
10716	Fill	10715	0.15	0.36	Primary Fill. Greyish blue. Silty sand, gravel inclusions		
10717	Fill	10715	1.2	0.12	Secondary Fill. Orangey grey, silty sand, friable		
10718	Fill	10715	2.6	0.36	Tertiary Fill. Light greyish brown, silty sand, friable		

Trench 108

General description

Trench devoid of archaeology. Consists of ploughsoil overlying silty sand with frequent flint pebbles.

Orientation

E-W

Length (m)

30

Width (m)

1.8

Avg. depth (m)

0.36

Context No.	Type	Fill Of	Width (m)	Depth (m)	Description	Finds	Date
10800	Layer			0.36	Ploughsoil. Brownish grey sandy silt with occasional flint pebble inclusions		
10801	Layer				Natural. Brownish orange silty sand with frequent flint pebble inclusions		

Trench 109

General description

Trench contains one modern ditch. Trench consists of ploughsoil overlying silty sand natural.

Orientation

NE-SW

Length (m)

30

Width (m)

1.8

Avg. depth (m)

0.38

Context No.	Type	Fill Of	Width (m)	Depth (m)	Description	Finds	Date
10900	Layer			0.38	Ploughsoil. Brownish grey silty sand with occasional rounded flint pebbles		
10901	Layer				Natural. Light brownish orange		

					silty sand with frequent rounded flint pebbles and gravel		
10902	Unexcavated feature		1.9		Modern. Ditch running E-W. Possibly with a field drain. Mixed fill of redeposited natural		
Trench 110							
General description					Orientation		E-W
Trench devoid of archaeology, consists of plough soil over yellow brown clay sand natural					Length (m)		30
					Width (m)		2
					Avg. depth (m)		0.4
Context No.	Type	Fill Of	Width (m)	Depth (m)	Description	Finds	Date
11000	Layer			0.35	Ploughsoil. Grey brown clayey silt		
11001	Layer				Natural. Light brownish orange silty sand with frequent rounded pebbles.		
11002	Void						
Trench 111							
General description					Orientation		N-S
Trench devoid of archaeology consists of plough soil overlying natural clayey sand					Length (m)		30
					Width (m)		2
					Avg. depth (m)		0.35
Context No.	Type	Fill Of	Width (m)	Depth (m)	Description	Finds	Date
11100	Layer		2	0.35	Ploughsoil. Greyish brown, sandy silt, occasional rounded stones		
11101	Layer		2		Natural. Reddish brown, clayey sand, frequent rounded stones		
Trench 112							
General description					Orientation		W-E
Trench contains one ditch. Consists of ploughsoil overlaying natural geology of sandy clay.					Length (m)		30
					Width (m)		2
					Avg. depth (m)		0.45
Context No.	Type	Fill Of	Width (m)	Depth (m)	Description	Finds	Date
11200	Layer			0.45	Ploughsoil. Brownish grey silty sand with		

					occasional rounded pebbles.		
11201	Layer				Natural. Reddish orange silty sand with frequent rounded pebbles.		
11202	Cut		1.1	0.46	Ditch		
11203	Fill	11202	1	0.35	Secondary Fill. Soft, dark greyish black silty clay	CBM	C15th-16th
11204	Fill	11202	0.38	0.18	Secondary Fill. Firm, greyish brown silty clay	Metal cartridge	Modern
11205	Fill	11202	0.08	0.46	Secondary Fill. Firm dark greyish black silty clay		

Trench 113

General description		Orientation	N-S
Trench devoid of archaeology. Consists of ploughsoil overlaying natural geology of sandy clay.		Length (m)	30
		Width (m)	1.8
		Avg. depth (m)	0.4

Context No.	Type	Fill Of	Width (m)	Depth (m)	Description	Finds	Date
11300	Layer			0.4	Ploughsoil. Greyish brown silty sand with occasional rounded pebbles.		
11301	Layer				Natural. Yellowish orange sandy clay		

Trench 114

General description		Orientation	W-E
Trench contains a single pit. Consists of ploughsoil overlaying natural geology of sandy clay.		Length (m)	30
		Width (m)	1.8
		Avg. depth (m)	0.4

Context No.	Type	Fill Of	Width (m)	Depth (m)	Description	Finds	Date
11400	Layer			0.4	Ploughsoil. Greyish brown silty sand with occasional rounded pebbles.		
11401	Layer				Natural. Yellowish orange sandy clay		
11402	Cut		0.51	0.15	Pit		
11403	Fill	11402	0.51	0.15	Deliberate Backfill. Soft brownish yellow silty clay		

Trench 115

General description		Orientation	N-S
Trench devoid of archaeology. Consists of ploughsoil overlaying natural geology of clayey sand.		Length (m)	30
		Width (m)	1.8

						Avg. depth (m)	0.42
Context No.	Type	Fill Of	Width (m)	Depth (m)	Description	Finds	Date
11500	Layer			0.4	Ploughsoil. Greyish brown silty sand with occasional rounded pebbles.		
11501	Layer				Natural. Orangish yellow clayey sand with moderate rounded pebbles and sub-angular flint fragments.		
Trench 116							
General description						Orientation	E-W
Trench contains one furrow and a pit. Consists of ploughsoil overlaying natural geology of sandy clay						Length (m)	30
						Width (m)	1.8
						Avg. depth (m)	0.3
Context No.	Type	Fill Of	Width (m)	Depth (m)	Description	Finds	Date
11600	Layer			0.35	Ploughsoil. Brownish grey silty sand with occasional rounded pebbles		
11601	Layer				Natural. Yellowish orange silty sand with frequent rounded pebbles.		
11602	Cut		1.7	0.1	Plough Furrow		
11603	Fill	11602	1.7	0.1	Primary Fill. Grey brown, sandy clay, soft		
11604	Cut		0.8	0.28	Pit.		
11605	Fill	11604	0.8	0.28	Secondary Fill. Brown grey, sandy clay, soft		
Trench 117							
General description						Orientation	N-S
Trench devoid of archaeology. Consists of ploughsoil overlying sandy gravel natural.						Length (m)	30
						Width (m)	1.8
						Avg. depth (m)	0.4
Context No.	Type	Fill Of	Width (m)	Depth (m)	Description	Finds	Date
11700	Layer			0.4	Ploughsoil. Brownish grey sandy silt with occasional rounded flint pebbles.		
11701	Layer				Natural. brownish orange silty sand		

					with frequent flint pebbles		
Trench 118							
General description					Orientation		W-E
Trench devoid of archaeology. Consists of ploughsoil overlaying natural geology of clayey sand with moderate gravel patches.					Length (m)		30
					Width (m)		1.8
					Avg. depth (m)		0.37
Context No.	Type	Fill Of	Width (m)	Depth (m)	Description	Finds	Date
11800	Layer			0.37	Ploughsoil. Greyish brown silty sand with occasional rounded pebbles.		
11801	Layer				Natural. Light orangish yellow clayey sand with frequent patches of brown and grey sandy gravel.		
Trench 119							
General description					Orientation		N-S
Trench revealed two ditches. Trench consists of plough soil over yellow brown clayey sand natural.					Length (m)		30
					Width (m)		2
					Avg. depth (m)		0.4
Context No.	Type	Fill Of	Width (m)	Depth (m)	Description	Finds	Date
11900	Layer			0.4	Ploughsoil. Greyish brown clayey silt		
11901	Layer				Natural. Yellowish brown silty sand with frequent rounded flint pebbles		
11902	Unexcavated feature		0.58		Modern. Greyish brown, soft, sand Occasional stones		
11903	Layer			0.05	Subsoil. Light yellow brown clay silt.	Flint	Neolithic
11904	Cut		0.7	0.2	Ditch		
11905	Fill	11904	0.7	0.2	Primary Fill. Dark greyish brown, Soft silty Sand		
Trench 120							
General description					Orientation		E-W
Trench devoid of archaeology consists of plough soil overlying natural clayey sand					Length (m)		30
					Width (m)		2
					Avg. depth (m)		0.4
Context No.	Type	Fill Of	Width (m)	Depth (m)	Description	Finds	Date

12000	Layer		2	0.35	Ploughsoil. Greyish brown, sandy silt, occasional rounded stones		
12001	Layer		2		Natural. Reddish brown, clayey sand, frequent roundest stones		

Trench 121							
General description					Orientation		N-S
Trench devoid of archaeology. Trench consists of ploughsoil overlying clayey sand natural.					Length (m)		30
					Width (m)		2
					Avg. depth (m)		0.36
Context No.	Type	Fill Of	Width (m)	Depth (m)	Description	Finds	Date
12100	Layer		2	0.36	Ploughsoil. Greyish brown, sandy silt, loose, occasional rounded stones		
12101	Layer		2		Natural. Reddish brown clayey sand with frequent rounded stones		

Trench 122							
General description					Orientation		E-W
Trench devoid of archaeology. Trench consists of ploughsoil overlying clayey sand natural.					Length (m)		30
					Width (m)		2
					Avg. depth (m)		0.37
Context No.	Type	Fill Of	Width (m)	Depth (m)	Description	Finds	Date
12200	Layer		2	0.37	Ploughsoil. Greyish brown, sandy silt, occasional rounded and sub angular flint stones		
12201	Layer		2		Natural. Reddish brown, clayey sand, frequent sub angular and rounded stones		

Trench 123							
General description					Orientation		N-S
Trench devoid of archaeology. Trench consists of ploughsoil overlying clayey sand natural.					Length (m)		30
					Width (m)		1.8
					Avg. depth (m)		0.37
Context No.	Type	Fill Of	Width (m)	Depth (m)	Description	Finds	Date
12300	Layer			0.36	Ploughsoil. Greyish brown silty sand with occasional rounded pebbles.		

12301	Layer				Natural. Yellowish orange clayey sand occasional rounded pebbles.		
Trench 124							
General description					Orientation	E-W	
Trench devoid of archaeology. Trench consists of ploughsoil overlying clayey sand natural.					Length (m)	30	
					Width (m)	1.8	
					Avg. depth (m)	0.38	
Context No.	Type	Fill Of	Width (m)	Depth (m)	Description	Finds	Date
12400	Layer			0.37	Ploughsoil. Greyish brown silty sand with occasional rounded pebbles.		
12401	Layer				Natural. Yellowish orange clayey sand with occasional gravel patches		
Trench 125							
General description					Orientation	N-S	
Trench devoid of archaeology. Trench consists of ploughsoil overlying silty sand natural.					Length (m)	30	
					Width (m)	1.8	
					Avg. depth (m)	0.25	
Context No.	Type	Fill Of	Width (m)	Depth (m)	Description	Finds	Date
12500	Layer			0.28	Ploughsoil. Light orange grey sandy silt with occasional pebbles		
12501	Layer				Natural. Light brownish orange silty sand with frequent pebbles		
Trench 126							
General description					Orientation	E-W	
Trench devoid of archaeology. Trench consists of ploughsoil overlying silty sand natural.					Length (m)	30	
					Width (m)	1.8	
					Avg. depth (m)	0.3	
Context No.	Type	Fill Of	Width (m)	Depth (m)	Description	Finds	Date
12600	Layer			0.3	Ploughsoil. Orange grey silty sand with moderate rounded pebble inclusions.		
12601	Layer				Natural. Light greyish orange silty sand with frequent rounded pebble inclusions.		

Trench 127							
General description					Orientation		N-S
Trench devoid of archaeology. Trench consists of ploughsoil overlying clayey sand natural.					Length (m)		30
					Width (m)		1.8
					Avg. depth (m)		0.34
Context No.	Type	Fill Of	Width (m)	Depth (m)	Description	Finds	Date
12700	Layer			0.34	Ploughsoil. Greyish brown silty sand with occasional rounded pebbles.		
12701	Layer				Natural. Yellowish orange sandy clay with frequent bands of brown sandy gravel.		
Trench 128							
General description					Orientation		E-W
Trench devoid of archaeology. Trench consists of ploughsoil overlying clayey sand natural.					Length (m)		30
					Width (m)		2
					Avg. depth (m)		0.37
Context No.	Type	Fill Of	Width (m)	Depth (m)	Description	Finds	Date
12800	Layer			0.4	Ploughsoil. Greyish brown clayey silt		
12801	Layer				Natural. Light brownish orange silty sand with frequent rounded pebbles.		
Trench 129							
General description					Orientation		E-W
Trench devoid of archaeology. Trench consists of ploughsoil overlying clayey sand natural.					Length (m)		30
					Width (m)		2
					Avg. depth (m)		0.4
Context No.	Type	Fill Of	Width (m)	Depth (m)	Description	Finds	Date
12900	Layer			0.4	Ploughsoil. Brownish grey silty sand with occasional rounded flint pebbles.		
12901	Layer				Natural. Mid brownish orange silty sand with frequent rounded flint pebbles.		
Trench 130							
General description					Orientation		E-W
					Length (m)		30

Trench devoid of archaeology. Trench consists of ploughsoil overlying clayey sand natural.						Width (m)	2
						Avg. depth (m)	0.4
Context No.	Type	Fill Of	Width (m)	Depth (m)	Description	Finds	Date
13000	Layer		2	0.4	Ploughsoil. Greyish brown, sandy silt		
13001	Layer		2		Natural. Reddish brown, clayey sand and frequent rounded stones		
Trench 131							
General description						Orientation	N-S
Trench devoid of archaeology consists of plough soil overlying natural clayey sand						Length (m)	30
						Width (m)	2
						Avg. depth (m)	0.4
Context No.	Type	Fill Of	Width (m)	Depth (m)	Description	Finds	Date
13100	Layer		2	0.4	Ploughsoil. Greyish brown, sandy silt, loose, occasional		
13101	Layer		2		Natural. Reddish brown, clayey silt, frequent rounded and occasional sub angular stones		
Trench 132							
General description						Orientation	E-W
Trench devoid of archaeology consists of plough soil overlying natural clayey sand						Length (m)	30
						Width (m)	2
						Avg. depth (m)	0.4
Context No.	Type	Fill Of	Width (m)	Depth (m)	Description	Finds	Date
13200	Layer		2	0.3	Ploughsoil. Greyish brown, sandy silt, loose, occasional rounded stones		
13201	Layer		2		Natural. Reddish brown, clayey sand, frequent rounded stones		
Trench 133							
General description						Orientation	E-W
Trench devoid of archaeology. Consists of ploughsoil overlying natural geology of sandy clay.						Length (m)	30
						Width (m)	1.8
						Avg. depth (m)	0.41
Context No.	Type	Fill Of	Width (m)	Depth (m)	Description	Finds	Date
13300	Layer			0.41	Ploughsoil. Greyish brown silty sand with		

					occasional rounded pebbles.		
13301	Layer				Natural. Reddish orange sandy clay with gravel patches.		
Trench 134							
General description					Orientation	N-S	
Trench devoid of archaeology. Consists of ploughsoil overlaying natural geology of sandy clay.					Length (m)	30	
					Width (m)	1.8	
					Avg. depth (m)	0.35	
Context No.	Type	Fill Of	Width (m)	Depth (m)	Description	Finds	Date
13400	Layer			0.35	Ploughsoil. Greyish brown silty sand with rounded pebbles.		
13401	Layer				Natural. Reddish orange sandy clay with moderate rounded pebbles and sub-angular flint fragments.		
Trench 135							
General description					Orientation	E-W	
Trench contains two pit like features. Trench consists of ploughsoil overlying sandy gravel natural.					Length (m)	30	
					Width (m)	1.8	
					Avg. depth (m)	0.38	
Context No.	Type	Fill Of	Width (m)	Depth (m)	Description	Finds	Date
13500	Layer			0.38	Ploughsoil. Orange grey silty sand with frequent flint pebble inclusions.		
13501	Layer				Natural. Brownish orange silty sand with frequent flint pebble inclusions		
13502	Layer			0.22	Subsoil. Greyish brown silty sand		
13503	Cut		0.5	0.45	Pit. Steep, irregular sides, concave base		
13504	Fill	13503	0.9	0.3	Primary Fill. Very pale grey brown, sand, slumping?		
13505	Fill	13503	0.9	0.1	Placed Deposit. Charcoal layer, <i>in situ</i> burning?	<S3>, BF	
13506	Fill	13503	1.15	0.25	Secondary Fill. Grey brown, sand and charcoal bands, re-dep?		
13507	Cut		1.1	0.4	Pit. Irregular oval, steep sides, concave base		

13508	Fill	13507	1	0.1	Charcoal layer. Firm black to grey brown silty sand	<S4>, BF	
13509	Fill	13507	0.53	0.29	Secondary Fill. grey brown, silty sand		
13510	Fill	13507	0.75	0.11	Secondary Fill. Grey brown, silty sand		
Trench 136							
General description						Orientation	N-S
Trench devoid of archaeology. Trench consists of ploughsoil overlying silty sand natural.						Length (m)	30
						Width (m)	1.8
						Avg. depth (m)	0.35
Context No.	Type	Fill Of	Width (m)	Depth (m)	Description	Finds	Date
13600	Layer			0.35	Ploughsoil. Orange grey sandy silt with frequent pebble inclusions		
13601	Layer				Natural. Light greyish orange silty sand with frequent rounded flint pebbles		
Trench 137							
General description						Orientation	E-W
Trench devoid of archaeology. Trench consists of ploughsoil overlying silty sand natural.						Length (m)	30
						Width (m)	1.8
						Avg. depth (m)	0.4
Context No.	Type	Fill Of	Width (m)	Depth (m)	Description	Finds	Date
13700	Layer			0.4	Ploughsoil.rownish grey sandy silt with occasional pebbles		
13701	Layer				Natural. Mid brownish orange silty sand with frequent pebbles		
Trench 138							
General description						Orientation	N-S
Trench devoid of archaeology. Trench consists of ploughsoil overlying clayey sand natural.						Length (m)	30
						Width (m)	2
						Avg. depth (m)	0.4
Context No.	Type	Fill Of	Width (m)	Depth (m)	Description	Finds	Date
13800	Layer			0.4	Ploughsoil. Mid greyish brown clayey silt		
13801	Layer				Natural. Mid brownish orange silty sand with frequent		

					rounded pebble inclusions		
Trench 139							
General description					Orientation	E-W	
Trench revealed one modern ditch. Trench consists of ploughsoil overlying clayey sand natural.					Length (m)	30	
					Width (m)	2	
					Avg. depth (m)	0.36	
Context No.	Type	Fill Of	Width (m)	Depth (m)	Description	Finds	Date
13900	Layer			0.35	Ploughsoil. Greyish brown clayey silt.		
13901	Layer				Natural. Brownish orange silty sand with frequent rounded pebble inclusions		
13902	Cut		0.9	0.5	Modern. Modern ditch for large black pipe - not bottomed, stopped at pipe depth.		
13903	Fill	13902	0.9	0.5	Deliberate Backfill		
13904	Void						
Trench 140							
General description					Orientation	N-S	
Trench contains one posthole and one ditch. Trench consists of ploughsoil overlying clayey sand natural.					Length (m)	30	
					Width (m)	2	
					Avg. depth (m)	0.39	
Context No.	Type	Fill Of	Width (m)	Depth (m)	Description	Finds	Date
14000	Layer			0.38	Ploughsoil. Greyish brown clayey silt		
14001	Layer				Natural. Yellow brown clayey sand, very gravelly		
14002	Cut		0.42	0.1	Pit		
14003	Fill	14002	0.42	0.1	Primary Fill. Soft yellowish brown sandy clay		
14004	Unexcavated feature		0.58		Ditch. Linear NE-SW. Mid grey brown, silty sand, firm		
Trench 141							
General description					Orientation	E-W	
Trench revealed one ditch. Trench consists of ploughsoil overlying gravelly sand natural.					Length (m)	30	
					Width (m)	2	
					Avg. depth (m)	0.4	
Context No.	Type	Fill Of	Width (m)	Depth (m)	Description	Finds	Date

14100	Layer			0.4	Ploughsoil. Greyish brown clayey silt		
14101	Layer				Natural. Yellowish brown clayey sand, very gravelly		
14102	Cut		1.04	0.42	Ditch		
14103	Fill	14102	0.52	0.24	Secondary Fill. Greyish brown, silty sand, friable		
14104	Fill	14102	1.04	0.2	Secondary Fill. Dark brownish grey, silty sand, loose		

Trench 142

General description	Orientation	N-S
Trench devoid of archaeology. Trench consists of ploughsoil overlying clayey sand natural.	Length (m)	
	Width (m)	2
	Avg. depth (m)	0.4

Context No.	Type	Fill Of	Width (m)	Depth (m)	Description	Finds	Date
14200	Layer		2	0.4	Ploughsoil. Greyish brown, sandy silt, loose, occasional rounded stones		
14201	Layer		2		Natural. Reddish brown, clayey sand with frequent rounded stones, occasional light yellowish brown sand patches		

Trench 143

General description	Orientation	W-E
Trench devoid of archaeology. Trench consists of ploughsoil overlying clayey sand natural.	Length (m)	30
	Width (m)	2
	Avg. depth (m)	0.37

Context No.	Type	Fill Of	Width (m)	Depth (m)	Description	Finds	Date
14300	Layer		2	0.37	Ploughsoil. Greyish brown, sandy silt, occasional rounded stones		
14301	Layer		2		Natural. Reddish brown clayey sand, occasional rounded stones		

Trench 144

General description	Orientation	NW-SE
Trench devoid of archaeology. Trench consists of ploughsoil overlying clayey sand natural.	Length (m)	30
	Width (m)	1.8

						Avg. depth (m)	0.36
Context No.	Type	Fill Of	Width (m)	Depth (m)	Description	Finds	Date
14400	Layer			0.36	Ploughsoil. Greyish brown silty sand with occasional rounded pebbles.		
14401	Layer				Natural. Yellowish orange clayey sand with patches of gravel and clay.		
Trench 145							
General description						Orientation	N-S
Trench devoid of archaeology. Trench consists of ploughsoil overlying clayey sand natural.						Length (m)	30
						Width (m)	1.8
						Avg. depth (m)	0.39
Context No.	Type	Fill Of	Width (m)	Depth (m)	Description	Finds	Date
14500	Layer			0.39	Ploughsoil. Greyish brown silty sand with occasional rounded pebbles.		
14501	Layer				Natural. Yellowish orange sandy clay with frequent patches of brown sandy gravel.		
Trench 146							
General description						Orientation	E-W
Trench devoid of archaeology. Trench consists of ploughsoil overlying gravelly sand natural.						Length (m)	30
						Width (m)	1.8
						Avg. depth (m)	0.34
Context No.	Type	Fill Of	Width (m)	Depth (m)	Description	Finds	Date
14600	Layer			0.34	Ploughsoil. Greyish brown sandy silt with frequent flint pebble inclusions.		
14601	Layer				Natural. Light brownish orange silty sand with frequent rounded flint pebbles.		
Trench 147							
General description						Orientation	N-S
Trench devoid of archaeology. Trench consists of ploughsoil overlying sandy silt natural.						Length (m)	30
						Width (m)	1.8
						Avg. depth (m)	0.37
Context No.	Type	Fill Of	Width (m)	Depth (m)	Description	Finds	Date

14700	Layer			0.37	Ploughsoil. Brownish grey sandy silt with occasional rounded pebble inclusions		
14701	Layer				Natural. Brownish orange sandy silt with frequent flint pebble inclusions.		
Trench 148							
General description					Orientation		E-W
Trench devoid of archaeology. Trench consists of ploughsoil overlying gravelly sand natural.					Length (m)		30
					Width (m)		1.8
					Avg. depth (m)		0.36
Context No.	Type	Fill Of	Width (m)	Depth (m)	Description	Finds	Date
14800	Layer			0.36	Ploughsoil. Greyish brown silty sand with occasional rounded pebbles		
14801	Layer				Natural. Orangish yellow clayey sand with patches of brown sandy gravel.		
Trench 149							
General description					Orientation		N-S
Trench contains three ditches. Consists of ploughsoil overlying gravelly sand natural.					Length (m)		30
					Width (m)		2
					Avg. depth (m)		0.4
Context No.	Type	Fill Of	Width (m)	Depth (m)	Description	Finds	Date
14900	Layer			0.45	Ploughsoil. Greyish brown clayey silt		
14901	Layer				Natural. Brownish orange silty sand with frequent rounded pebble inclusions		
14902	Cut		0.82	0.4	Ditch		
14903	Fill	14902	0.1	0.1	Secondary Fill. Greyish brown, silty sand, loose		
14904	Fill	14902	0.72	0.36	Secondary Fill. Light brownish grey, silty sand, loose	FC	Preh-Med
14905	Cut		1.36	0.36	Ditch		
14906	Fill	14905	1.36	0.36	Secondary Fill. Dark brownish grey, silty sand, loose	Pot	EIA
14907	Unexcavated feature		0.81		Modern. Ditch with drain running NW/SE- seen in TR139. Mixed fill of orange and grey		

					natural, silty clay, firm		
Trench 150							
General description					Orientation	E-W	
Trench devoid of archaeology. Trench consists of ploughsoil overlying clayey sand natural.					Length (m)	30	
					Width (m)	2	
					Avg. depth (m)	0.4	
Context No.	Type	Fill Of	Width (m)	Depth (m)	Description	Finds	Date
15000	Layer			0.4	Ploughsoil. Greyish brown clayey silt		
15001	Layer				Natural. Yellowish brown clayey sand, very gravelly		

Trench 151							
General description					Orientation	N-S	
Trench devoid of archaeology. Trench consists of ploughsoil overlying clayey sand natural.					Length (m)	30	
					Width (m)	2	
					Avg. depth (m)	0.37	
Context No.	Type	Fill Of	Width (m)	Depth (m)	Description	Finds	Date
15100	Layer			0.35	Ploughsoil. Greyish brown clayey silt		
15101	Layer				Natural. Yellowish brown clayey sand very gravelly		

Trench 152							
General description					Orientation	E-W	
Trench devoid of archaeology. Trench consists of ploughsoil overlying clayey sand natural.					Length (m)	30	
					Width (m)	2	
					Avg. depth (m)	0.4	
Context No.	Type	Fill Of	Width (m)	Depth (m)	Description	Finds	Date
15200	Layer		2	0.4	Ploughsoil. Greyish brown, sandy silt, occasional rounded stones		
15201	Layer		2		Natural. Light greyish brown sandy silt with frequent patches of gravel		

Trench 153							
General description					Orientation	N-S	
Trench devoid of archaeology. Trench consists of ploughsoil overlying clayey sand natural.					Length (m)	30	
					Width (m)	2	
					Avg. depth (m)	0.4	

Context No.	Type	Fill Of	Width (m)	Depth (m)	Description	Finds	Date
15300	Layer		2	0.4	Ploughsoil. Greyish brown, sandy silt, loose, occasional rounded stones		
15301	Layer		2		Natural. Reddish brown, clayey sand, frequent rounded stones and fine manganese		
Trench 154							
General description					Orientation	E-W	
Trench devoid of archaeology. Trench consists of ploughsoil overlying clayey sand natural.					Length (m)	30	
					Width (m)	1.8	
					Avg. depth (m)	0.39	
Context No.	Type	Fill Of	Width (m)	Depth (m)	Description	Finds	Date
15400	Layer			0.39	Ploughsoil. Greyish brown silty sand with occasional rounded pebbles.		
15401	Layer				Natural. Yellowish orange clayey sand with moderate rounded stones and patches of dark orange clay.		
Trench 155							
General description					Orientation	N-S	
Trench revealed a modern pit. Trench consists of ploughsoil overlying clayey sand natural.					Length (m)	30	
					Width (m)	1.8	
					Avg. depth (m)	0.3	
Context No.	Type	Fill Of	Width (m)	Depth (m)	Description	Finds	Date
15500	Layer			0.3	Ploughsoil. Greyish brown silty sand with occasional rounded pebbles.		
15501	Layer				Natural. Orangish yellow clayey sand with moderate rounded stones and sub-angular flint fragments.		
15502	Cut		0.44	0.04	Modern		
15503	Fill	15502	0.44	0.04	Deliberate Backfill		
15504	Cut		0.2	0.18	Natural Feature. Natural feature at centre of trench. Firm. Dark greyish black. Silty clay. No inclusions.		

Trench 156							
General description					Orientation		N-S
Trench revealed two ditches. Consists of ploughsoil and subsoil overlying natural geology of sandy silt.					Length (m)		30
					Width (m)		2
					Avg. depth (m)		0.5
Context No.	Type	Fill Of	Width (m)	Depth (m)	Description	Finds	Date
15600	Layer			0.25	Ploughsoil. Brownish grey sandy silt.		
15601	Layer			0.14	Subsoil. Reddish brown sandy silt.		
15602	Layer				Natural. Light reddish brown sandy silt.		
15603	Cut		1.61	0.27	Ditch		
15604	Fill	15603	1.61	0.27	Primary Fill. Dark greyish brown clayey silt.		
15605	Unexcavated feature		1.12		Ditch. Dark brownish grey clayey silt.		
Trench 157							
General description					Orientation		E-W
Trench revealed four ditches. Consists of ploughsoil and subsoil overlying natural geology of sandy silt.					Length (m)		30
					Width (m)		2
					Avg. depth (m)		0.51
Context No.	Type	Fill Of	Width (m)	Depth (m)	Description	Finds	Date
15700	Layer			0.31	Ploughsoil. Brownish grey sandy silt.		
15701	Layer			0.2	Subsoil. Reddish brown sandy silt.		
15702	Layer				Natural. Light brownish red sandy silt.		
15703	Cut		0.52	0.13	Ditch		
15704	Fill	15703	0.52	0.13	Primary Fill. Light brownish grey sandy silt.	Pot	MBA-MIA
15705	Cut		0.33	0.34	Modern. Modern pipe trench.		
15706	Cut		0.41	0.11	Ditch		
15707	Fill	15706	0.41	0.11	Primary Fill. Light brownish grey sandy silt.	Pot	LBA-MIA
15708	Cut		1.64	0.31	Ditch		
15709	Fill	15708	1.64	0.31	Primary Fill. Dark brownish grey sandy silt.	Pot, Flint	LBA-MIA
Trench 158							
General description					Orientation		N-S
					Length (m)		30

Trench revealed three ditches. Consists of ploughsoil and subsoil overlying natural geology of silty sand with gravels.					Width (m)	2	
					Avg. depth (m)	0.35	
Context No.	Type	Fill Of	Width (m)	Depth (m)	Description	Finds	Date
15800	Layer			0.3	Ploughsoil. Brownish grey sandy silt.		
15801	Layer			0.09	Subsoil. Greyish brown sandy silt.		
15802	Layer				Natural. Light reddish brown silty sand with gravels.		
15803	Cut		2.64	0.32	Ditch		
15804	Fill	15803	2.64	0.32	Primary Fill. Greyish brown silty sand.		
15805	Unexcavated feature		0.6		Ditch. Light brownish grey sandy silt.		
15806	Cut	15806	0.73	0.21	Ditch. NE-SW		
15807	Cut		3.8	0.18	Natural Feature. Dark greyish brown silty sand.		
15808	Fill	15806	0.73	0.21	Primary Fill. Light brownish grey sandy silt.	Pot	MBA-MIA

Trench 159

General description					Orientation	E-W	
Trench revealed one ditch. Consists of ploughsoil and subsoil overlying natural geology of sandy clay with gravels.					Length (m)	30	
					Width (m)	2	
					Avg. depth (m)	0.4	
Context No.	Type	Fill Of	Width (m)	Depth (m)	Description	Finds	Date
15900	Layer			0.3	Ploughsoil. Brownish grey sandy silt.		
15901	Layer			0.09	Subsoil. Greyish brown sandy silt.		
15902	Layer				Natural. Reddish brown sandy clay with gravels.		
15903	Cut		0.47	0.11	Ditch		
15904	Fill	15903	0.47	0.11	Primary Fill. Greyish brown sandy silt.		

Trench 160

General description					Orientation	N-S	
Trench revealed one ditch. Consists of ploughsoil and subsoil overlying natural geology of sandy gravels.					Length (m)	30	
					Width (m)	2	
					Avg. depth (m)	0.45	
Context No.	Type	Fill Of	Width (m)	Depth (m)	Description	Finds	Date
16000	Layer			0.35	Ploughsoil. Brownish grey sandy silt.		
16001	Layer			0.07	Subsoil. Greyish brown sandy silt.		

16002	Layer				Natural. Brownish grey sandy gravels.		
16003	Cut		1.62	0.3	Ditch		
16004	Fill	16003	1.62	0.3	Primary Fill. Brownish grey clayey silt.		
Trench 161							
General description					Orientation	NEE-SWW	
Trench devoid of archaeology. Trench consists of ploughsoil and subsoil overlying natural geology of sandy silt with gravels.					Length (m)	30	
					Width (m)	2	
					Avg. depth (m)	0.41	
Context No.	Type	Fill Of	Width (m)	Depth (m)	Description	Finds	Date
16100	Layer			0.25	Ploughsoil. Brownish grey sandy silt.		
16101	Layer			0.16	Subsoil. Reddish brown sandy silt.		
16102	Layer				Natural. Light yellowish brown sandy silt with gravels.		
Trench 162							
General description					Orientation	E-W	
Trench devoid of archaeology. Consists of ploughsoil and subsoil overlying natural geology of sandy silt with gravels.					Length (m)	30	
					Width (m)	2	
					Avg. depth (m)	0.43	
Context No.	Type	Fill Of	Width (m)	Depth (m)	Description	Finds	Date
16200	Layer			0.3	Ploughsoil. Brownish grey sandy silt.		
16201	Layer			0.13	Subsoil. Reddish brown sandy silt.		
16202	Layer				Natural. Light yellow brown sandy silt with gravels.		
Trench 163							
General description					Orientation	NW-SE	
Trench revealed three ditches. Consists of ploughsoil and subsoil overlying natural geology of sandy silt with gravels.					Length (m)	30	
					Width (m)	2	
					Avg. depth (m)	0.35	
Context No.	Type	Fill Of	Width (m)	Depth (m)	Description	Finds	Date
16300	Layer			0.18	Ploughsoil. Brownish grey sandy silt.		
16301	Layer			0.17	Subsoil. Greyish brown sandy silt.		
16302	Layer				Natural. Reddish brown sandy silt with gravels.		

16303	Cut		0.97	0.22	Ditch		
16304	Fill	16303	0.97	0.22	Primary Fill. Dark greyish brown sandy silt.		
16305	Cut		1.27	0.08	Ditch		
16306	Fill	16305	1.27	0.08	Primary Fill. Dark brownish grey sandy silt.		
16307	Cut		1.55	0.24	Ditch		
16308	Fill	16307	1.55	0.24	Primary Fill. Brownish grey sandy silt.	Flint	Preh

Trench 164

General description

Orientation

NW-SE

Trench revealed one posthole. Consists of ploughsoil and subsoil overlying natural geology of sandy silt with gravels.

Length (m)

30

Width (m)

2

Avg. depth (m)

0.48

Context No.	Type	Fill Of	Width (m)	Depth (m)	Description	Finds	Date
16400	Layer			0.26	Ploughsoil. Brownish grey sandy silt.		
16401	Layer			0.16	Subsoil. Reddish brown sandy silt.		
16402	Layer				Natural. Light reddish brown sandy silt with gravels.		
16403	Cut		0.26	0.08	Posthole		
16404	Fill	16403	0.26	0.08	Secondary Fill. Greyish brown silty clay.		
16405	Cut		0.84	0.12	Natural Feature. Greyish brown sandy silt.		

Trench 165

General description

Orientation

N-S

Trench devoid of archaeology. Consists of ploughsoil and subsoil overlying natural geology of sandy silt with gravels.

Length (m)

30

Width (m)

2

Avg. depth (m)

0.5

Context No.	Type	Fill Of	Width (m)	Depth (m)	Description	Finds	Date
16500	Layer			0.31	Ploughsoil. Brownish grey sandy silt.		
16501	Layer			0.19	Subsoil. Greyish brown sandy silt.		
16502	Layer				Natural. Reddish brown sandy silt with gravels.		

Trench 166

General description

Orientation

E-W

Length (m)

30

Trench consists of ploughsoil and subsoil overlying natural geology of sandy silt with gravels.						Width (m)	2
						Avg. depth (m)	0.4
Context No.	Type	Fill Of	Width (m)	Depth (m)	Description	Finds	Date
16600	Layer			0.22	Ploughsoil. Brownish grey sandy silt.		
16601	Layer			0.18	Subsoil. Greyish brown sandy silt.		
16602	Layer				Natural. Reddish brown sandy silt with gravels.		
16603	Cut			0.23	Natural Feature. Greyish brown sandy silt.		
Trench 167							
General description						Orientation	N-S
Trench revealed two postholes. Consists of ploughsoil and subsoil overlying natural geology of sandy silt with gravels.						Length (m)	30
						Width (m)	2
						Avg. depth (m)	0.33
Context No.	Type	Fill Of	Width (m)	Depth (m)	Description	Finds	Date
16700	Layer			0.18	Ploughsoil. Brownish grey sandy silt.		
16701	Layer			0.15	Subsoil. Greyish brown sandy silt.		
16702	Layer				Natural. Reddish brown, sandy silt with gravels.		
16703	Cut		0.2	0.17	Posthole		
16704	Fill	16703	0.2	0.17	Primary Fill. Blackish grey silt.	<S5>	
16705	Cut		0.26	0.09	Posthole		
16706	Fill	16705	0.26	0.09	Primary Fill. Blackish-greyish brown silt.	<S6>	
Trench 168							
General description						Orientation	E-W
Trench revealed one pit. Consists of ploughsoil and subsoil overlying natural geology of sandy silt with gravels.						Length (m)	30
						Width (m)	2
						Avg. depth (m)	0.43
Context No.	Type	Fill Of	Width (m)	Depth (m)	Description	Finds	Date
16800	Layer			0.23	Ploughsoil. Brownish grey sandy silt.	Flint	
16801	Layer			0.2	Subsoil. Greyish brown sandy silt.		
16802	Layer				Natural. Reddish brown sandy silt with gravels.		
16803	Cut		1.09	0.11	Pit		
16804	Fill		1.09	0.11	Primary Fill. Brownish grey silty clay.	<S7>	

Trench 169							
General description					Orientation		N-S
Trench revealed one pit. Consists of ploughsoil and subsoil overlying natural geology of sandy silt with gravels.					Length (m)		30
					Width (m)		2
					Avg. depth (m)		0.45
Context No.	Type	Fill Of	Width (m)	Depth (m)	Description	Finds	Date
16900	Layer			0.32	Ploughsoil. Brownish grey sandy silt.		
16901	Layer			0.14	Subsoil. Reddish brown sandy silt.		
16902	Layer				Natural. Light reddish brown sandy silty with gravels.		
16903	Cut		0.69	0.44	Pit		
16904	Fill	16903	0.22	0.1	Primary Fill. Light yellowish grey clayey sand.		
16905	Fill	16903	0.66	0.32	Secondary Fill. Greyish brown sandy silt.		
Trench 170							
General description					Orientation		E-W
Trench revealed one ditch. Consists of ploughsoil and subsoil overlying natural geology of sandy silt with gravels.					Length (m)		30
					Width (m)		2
					Avg. depth (m)		0.44
Context No.	Type	Fill Of	Width (m)	Depth (m)	Description	Finds	Date
17000	Layer			0.3	Ploughsoil. Brownish grey sandy silt.		
17001	Layer			0.14	Subsoil. Reddish brown sandy silt.		
17002	Layer				Natural. Light reddish brown sandy silt with gravels.		
17003	Cut		0.53	0.21	Ditch		
17004	Fill	17003		0.21	Primary Fill. Dark brownish grey sandy silt.		
Trench 171							
General description					Orientation		E-W
Trench devoid of archaeology. Consists of ploughsoil and subsoil overlying natural geology of sandy silt with gravels.					Length (m)		30
					Width (m)		2
					Avg. depth (m)		0.47
Context No.	Type	Fill Of	Width (m)	Depth (m)	Description	Finds	Date
17100	Layer			0.27	Ploughsoil. Brownish grey sandy silt.		
17101	Layer			0.15	Subsoil. Mid reddish brown sandy silt.		

17102	Layer				Natural. Light reddish brown sandy silt with gravels.		
Trench 172							
General description					Orientation	N-S	
Trench revealed one ditch and one pit. Consists of ploughsoil and subsoil overlying natural geology of sandy silt with gravels.					Length (m)	30	
					Width (m)	2	
					Avg. depth (m)	0.46	
Context No.	Type	Fill Of	Width (m)	Depth (m)	Description	Finds	Date
17200	Layer			0.25	Ploughsoil. Dark grey sandy clay.		
17201	Layer			0.18	Subsoil. Brownish grey sandy clay.		
17202	Layer				Natural. Reddish brown sandy silt with gravels.		
17203	Cut		1.17	0.42	Ditch		
17204	Fill	17203	1.17	0.42	Primary Fill. Dark greyish brown sandy silt.		
17205	Cut		0.7	0.38	Pit		
17206	Fill	17205	0.7	0.38	Primary Fill. Dark greyish brown sandy silt.		
Trench 173							
General description					Orientation	E-W	
Trench revealed two ditches. Consists of ploughsoil and subsoil overlying natural geology of sandy silt with gravels.					Length (m)	30	
					Width (m)	2	
					Avg. depth (m)	0.46	
Context No.	Type	Fill Of	Width (m)	Depth (m)	Description	Finds	Date
17300	Layer			0.36	Ploughsoil. Brownish grey sandy silt.		
17301	Layer			0.12	Subsoil. Reddish brown sandy silt.		
17302	Layer				Natural. Light reddish brown sandy silt with gravels.		
17303	Cut		1.56	0.3	Ditch		
17304	Fill	17303	1.56	0.3	Secondary Fill. Greyish brown sandy silt.		
17305	Cut		1.54	0.36	Ditch		
17306	Fill		1.54	0.36	Yellowish brown, sandy clay.	Pot	AD 43-410
Trench 174							
General description					Orientation	N-S	
					Length (m)	30	

Trench devoid of archaeology. Consists of ploughsoil and subsoil overlying natural geology of sandy silt with gravels.					Width (m)	2	
					Avg. depth (m)	0.49	
Context No.	Type	Fill Of	Width (m)	Depth (m)	Description	Finds	Date
17400	Layer			0.33	Ploughsoil. Brownish grey sandy silt.		
17401	Layer			0.16	Subsoil. Reddish brown sandy silt.		
17402	Layer				Natural. Light reddish brown sandy silt with gravels.		
17403	Cut		1.02	0.21	Natural Feature. Greyish brown sandy silt. Tree throw.		

Trench 175

General description					Orientation	E-W	
Trench devoid of archaeology. Consists of ploughsoil and subsoil overlying natural geology of sandy silt with gravels.					Length (m)	30	
					Width (m)	2	
					Avg. depth (m)	0.44	
Context No.	Type	Fill Of	Width (m)	Depth (m)	Description	Finds	Date
17500	Layer			0.28	Ploughsoil. Brownish grey sandy silt.		
17501	Layer			0.18	Subsoil. Reddish brown sandy silt.		
17502	Layer				Natural. Light reddish brown sandy silt with gravels.		
17503	Cut		1.5	0.2	Natural Feature. Brown- light yellowish brown sandy silt.		

Trench 176

General description					Orientation	N-S	
Trench revealed one ditch and two pits. Consists of ploughsoil and subsoil overlying natural geology of sandy silt with gravels.					Length (m)	30	
					Width (m)	2	
					Avg. depth (m)	0.43	
Context No.	Type	Fill Of	Width (m)	Depth (m)	Description	Finds	Date
17600	Layer			0.29	Ploughsoil. Brownish grey sandy silt.		
17601	Layer			0.13	Subsoil. Reddish brown sandy silt.		
17602	Layer				Natural. Light reddish brown sandy silt.		
17603	Cut		0.38	0.17	Ditch		
17604	Fill	17603	0.38	0.17	Primary Fill. Light yellowish brown sandy clay.		
17605	Cut		0.43	0.24	Ditch		

17606	Fill	17605	0.43	0.24	Primary Fill. Light yellowish brown sandy clay.		
17607	Cut		0.78	0.15	Pit		
17608	Fill	17607	0.78	0.15	Primary Fill. Reddish brown sandy clay.		
17609	Cut		0.81	0.14	Pit		
17610	Fill	17609	0.81	0.14	Primary Fill. Reddish brown sandy clay.		
17611	Layer				Natural. Gravel natural layer.		
17612	Layer				Natural. Whitish yellow sandy clay.		

Trench 177

General description					Orientation	E-W
Trench revealed four ditches. Consists of ploughsoil and subsoil overlying the natural geology of sandy silt with gravels.					Length (m)	30
					Width (m)	2
					Avg. depth (m)	0.45

Context No.	Type	Fill Of	Width (m)	Depth (m)	Description	Finds	Date
17700	Layer			0.28	Ploughsoil. Mid brownish grey sandy silt.		
17701	Layer			0.21	Subsoil. Mid reddish brown sandy silt.		
17702	Layer				Natural. Light reddish brown sandy silt with gravels.		
17703	Cut		0.35	0.07	Ditch		
17704	Fill	17703	0.35	0.07	Primary Fill. Light grey sandy silt.		
17705	Cut		0.56	0.17	Ditch		
17706	Fill	17705	0.56	0.17	Primary Fill. Greyish brown sandy silt.		
17707	Cut		0.52	0.15	Ditch		
17708	Fill	17707	0.52	0.15	Primary Fill. Greyish brown sandy silt.		
17709	Cut		0.87	0.14	Ditch		
17710	Fill	17709	0.87	0.14	Primary Fill. Brownish grey sandy silt.	Metal object?	
17711	Cut		1.15	0.11	Natural Feature. Mid grey silty sand.		

Trench 178

General description					Orientation	E-W
					Length (m)	30

Trench devoid of archaeology. Consists of ploughsoil and subsoil overlying natural geology of silty sand.						Width (m)	2
						Avg. depth (m)	0.48
Context No.	Type	Fill Of	Width (m)	Depth (m)	Description	Finds	Date
17800	Layer			0.36	Ploughsoil. Brownish grey sandy silt.		
17801	Layer			0.13	Subsoil. Greyish brown sandy silt.		
17802	Layer				Natural. Reddish brown silty sand.		
17803	Cut		1.48	0.16	Natural Feature. Greyish brown silty sand.		
Trench 179							
General description						Orientation	N-S
Trench revealed one pit. Consists of ploughsoil and subsoil overlying natural geology of silty sand.						Length (m)	30
						Width (m)	2
						Avg. depth (m)	0.55
Context No.	Type	Fill Of	Width (m)	Depth (m)	Description	Finds	Date
17900	Layer			0.35	Ploughsoil. Brownish grey sandy silt.		
17901	Layer			0.13	Subsoil. Greyish brown sandy silt.		
17902	Layer				Natural. Reddish brown silty sand.		
17903	Cut		8.5	0.49	Pit		
17904	Fill	17903	8.5	0.49	Primary Fill. Greyish brown silty sand.		
Trench 180							
General description						Orientation	E-W
Trench revealed one ditch and two pits. Consists of ploughsoil and subsoil overlying natural geology of silty sand.						Length (m)	30
						Width (m)	2
						Avg. depth (m)	0.4
Context No.	Type	Fill Of	Width (m)	Depth (m)	Description	Finds	Date
18000	Layer			0.35	Ploughsoil. Brownish grey sandy silt.		
18001	Layer			0.09	Subsoil. Greyish brown silty sand.		
18002	Layer				Natural. Mid reddish brown silty sand.		
18003	Cut		2.75	0.61	Ditch		
18004	Fill			0.15	Primary Fill. Light reddish brown sandy silt.		

18005	Fill	18003		0.61	Secondary Fill. Greyish brown sandy silt.		
18006	Fill	18003		0.14	Primary Fill. Reddish brown sandy silt.		
18007	Cut		1.06	0.49	Pit		
18008	Fill	18007	1.06	0.49	Primary Fill. Greyish brown sandy silt.	Pot	MBA-MIA
18009	Cut		0.63	0.49	Pit		
18010	Fill	18009		0.16	Primary Fill. Reddish brown sandy silt.		
18011	Fill	18009		0.33	Secondary Fill. Greyish brown sandy silt.		

Trench 181

General description	Orientation	N-S
Trench devoid of archaeology. Consists of ploughsoil and subsoil overlying natural geology of sandy silt with gravels.	Length (m)	30
	Width (m)	2
	Avg. depth (m)	0.4

Context No.	Type	Fill Of	Width (m)	Depth (m)	Description	Finds	Date
18100	Layer			0.32	Ploughsoil. Brownish grey sandy silt.		
18101	Layer			0.11	Subsoil. Greyish brown sandy silt.		
18102	Layer				Natural. Reddish brown sandy silt with gravels.		
18103	Void						

Trench 182

General description	Orientation	E-W
Trench devoid of archaeology. Consists of ploughsoil and subsoil overlying natural geology of silty sand with gravels.	Length (m)	30
	Width (m)	2
	Avg. depth (m)	0.4

Context No.	Type	Fill Of	Width (m)	Depth (m)	Description	Finds	Date
18200	Layer			0.35	Ploughsoil. Brownish grey sandy silt.		
18201	Layer			0.12	Subsoil. Greyish brown sandy silt.		
18202	Layer				Natural. Reddish brown silty sand with gravels.		

Trench 183

General description	Orientation	N-S
---------------------	-------------	-----

Trench devoid of archaeology. Consists of ploughsoil and subsoil overlying natural geology of sandy silt with gravels.						Length (m)		30
						Width (m)		2
						Avg. depth (m)		0.4
Context No.	Type	Fill Of	Width (m)	Depth (m)	Description	Finds	Date	
18300	Layer			0.32	Ploughsoil. Brownish grey sandy silt.			
18301	Layer			0.11	Subsoil. Greyish brown sandy silt.			
18302	Layer				Natural. Light reddish brown sandy silt with gravels.			
Trench 184								
General description						Orientation		N-S
Trench revealed one ditch and one pit. Consists of ploughsoil and subsoil overlying natural geology of sandy silt with gravels.						Length (m)		30
						Width (m)		2
						Avg. depth (m)		0.35
Context No.	Type	Fill Of	Width (m)	Depth (m)	Description	Finds	Date	
18400	Layer			0.28	Ploughsoil. Brownish grey sandy silt.	Flint		
18401	Layer			0.14	Subsoil. Greyish brown sandy silt.			
18402	Layer				Natural. Reddish brown sandy silt with gravels.			
18403	Cut		1.92	0.35	Pit			
18404	Fill	18403	1.92	0.35	Primary Fill. Greyish brown silty sand.			
18405	Cut		0.47		Ditch. Brownish grey silty sand.			
Trench 185								
General description						Orientation		E-W
Trench revealed one ditch. Consists of ploughsoil and subsoil overlying natural geology of sandy silt with gravels.						Length (m)		30
						Width (m)		2
						Avg. depth (m)		0.4
Context No.	Type	Fill Of	Width (m)	Depth (m)	Description	Finds	Date	
18500	Layer			0.32	Ploughsoil. Brownish grey sandy silt.			
18501	Layer			0.11	Subsoil. Greyish brown clayey silt.			
18502	Layer				Natural. Reddish brown sandy silt with gravels.			
18503	Cut		1.1	0.23	Ditch			

18504	Fill	18503	1.1	0.23	Greyish brown silty sand.		
18505	Void						
Trench 186							
General description					Orientation		N-S
Trench devoid of archaeology. Consists of ploughsoil and subsoil overlying natural geology of silty sand with gravels.					Length (m)		30
					Width (m)		2
					Avg. depth (m)		0.45
Context No.	Type	Fill Of	Width (m)	Depth (m)	Description	Finds	Date
18600	Layer			0.35	Ploughsoil. Brownish grey sandy silt.		
18601	Layer			0.14	Subsoil. Greyish brown clayey silt.		
18602	Layer				Natural. Reddish brown silty sand with gravels.		
Trench 187							
General description					Orientation		E-W
Trench revealed one ditch. Consists of ploughsoil and subsoil overlying natural geology of gravelly sand.					Length (m)		30
					Width (m)		2
					Avg. depth (m)		0.45
Context No.	Type	Fill Of	Width (m)	Depth (m)	Description	Finds	Date
18700	Layer			0.37	Ploughsoil. Brownish grey sandy silt.		
18701	Layer			0.15	Subsoil. Greyish brown clayey silt.		
18702	Layer				Natural. Greyish yellow gravelly sand.		
18703	Cut		0.64	0.18	Ditch		
18704	Fill	18703	0.64	0.18	Primary Fill. Greyish brown sandy silt.	Pot	AD 43-410
Trench 188							
General description					Orientation		N-S
Trench devoid of archaeology. Consists of ploughsoil and subsoil overlying natural geology of silty sand with gravels.					Length (m)		30
					Width (m)		2
					Avg. depth (m)		0.5
Context No.	Type	Fill Of	Width (m)	Depth (m)	Description	Finds	Date
18800	Layer			0.35	Ploughsoil. Brownish grey sandy silt.		
18801	Layer			0.27	Subsoil. Greyish brown clayey silt.		

18802	Layer				Natural. Greyish yellow silty sand with gravels.		
Trench 189							
General description					Orientation	E-W	
Trench revealed one pit. Consists of ploughsoil and subsoil overlying natural geology of sandy clay.					Length (m)	30	
					Width (m)	2	
					Avg. depth (m)	0.45	
Context No.	Type	Fill Of	Width (m)	Depth (m)	Description	Finds	Date
18900	Layer			0.3	Ploughsoil. Brownish grey sandy silt.		
18901	Layer			0.19	Subsoil. Greyish brown clayey silt.		
18902	Layer				Natural. Mid reddish brown sandy clay.		
18903	Cut		0.61	0.14	Pit		
18904	Fill	18903	0.61	0.14	Primary Fill. Yellowish grey silty clay.		
Trench 190							
General description					Orientation	NE-SW	
Trench revealed one ditch. Consists of ploughsoil and subsoil overlying natural geology of gravelly sand.					Length (m)	30	
					Width (m)	2	
					Avg. depth (m)	0.35	
Context No.	Type	Fill Of	Width (m)	Depth (m)	Description	Finds	Date
19000	Layer			0.35	Ploughsoil. Brownish grey sandy silt.		
19001	Layer			0.14	Subsoil. Greyish brown clayey silt.		
19002	Layer				Natural. Reddish brown gravelly sand.		
19003	Cut		1.17	0.46	Ditch		
19004	Fill	19003	0.6	0.15	Tertiary Fill. Light grey silty sand.		
19005	Layer				Natural. Reddish-yellowish brown sand.		
19006	Fill	19003	1.07	0.34	Other Fill. Greyish brown silty sand.		
19007	Void						
19008	Cut			0.14	Natural Feature. Dark reddish brown sandy silt.		
Trench 191							

General description						Orientation		E-W
Trench revealed one ditch. Consists of ploughsoil and subsoil overlying natural geology of clayey sand.						Length (m)		30
						Width (m)		2.1
						Avg. depth (m)		0.38
Context No.	Type	Fill Of	Width (m)	Depth (m)	Description	Finds	Date	
19100	Layer			0.34	Ploughsoil. Dark brownish grey, clayey silt, moderately compact.			
19101	Layer			0.04	Subsoil. Ploughsoil mixed with yellowish orange clayey sand with occasional sub-angular stones.			
19102	Layer				Natural. Light greyish brown clayey sand with occasional sub-angular stones.			
19103	Cut		1	0.2	Ditch			
19104	Fill	19103	1	0.2	Secondary Fill. Light brownish grey, silty sand, moderately compact.			
Trench 192								
General description						Orientation		N-S
Trench devoid of archaeology. Consists of ploughsoil and subsoil overlying natural geology of sandy clay.						Length (m)		30
						Width (m)		2.1
						Avg. depth (m)		0.41
Context No.	Type	Fill Of	Width (m)	Depth (m)	Description	Finds	Date	
19200	Layer			0.35	Ploughsoil. Dark brownish grey, clayey silt, moderately compact.			
19201	Layer			0.06	Subsoil. Plough soil mixed with brownish orange sandy clay with occasional sub-angular stones.			
19202	Layer				Natural. Brownish orange sandy clay with occasional sub-angular stones.			
Trench 193								
General description						Orientation		E-W
						Length (m)		30

Trench devoid of archaeology. Consists of ploughsoil overlying natural geology of sandy clay.						Width (m)	2.1
						Avg. depth (m)	0.35
Context No.	Type	Fill Of	Width (m)	Depth (m)	Description	Finds	Date
19300	Layer			0.35	Ploughsoil. Dark brownish grey, clayey silt, moderately compact.		
19301	Layer				Natural. Brownish yellow sandy clay with occasional sub-angular stones.		
Trench 194							
General description						Orientation	N-S
Trench devoid of archaeology. Consists of ploughsoil and subsoil overlying natural geology of sandy clay.						Length (m)	30
						Width (m)	2.1
						Avg. depth (m)	0.38
Context No.	Type	Fill Of	Width (m)	Depth (m)	Description	Finds	Date
19400	Layer			0.33	Ploughsoil. Dark brownish grey, clayey silt, moderately compact.		
19401	Layer			0.05	Subsoil. Light brownish orange, clayey silt, firm.		
19402	Layer				Natural. Orangish brown, sandy clay with clay patches, firm.		
Trench 195							
General description						Orientation	E-W
Trench devoid of archaeology. Consists of ploughsoil and subsoil overlying natural geology of sandy clay.						Length (m)	30
						Width (m)	2.1
						Avg. depth (m)	0.42
Context No.	Type	Fill Of	Width (m)	Depth (m)	Description	Finds	Date
19500	Layer			0.38	Ploughsoil. Dark brownish grey, clayey silt, moderately compact.		
19501	Layer			0.04	Subsoil. Light brownish orange, clayey silt, firm.		
19502	Layer				Natural. Orange brown, sandy clay with gravelly patches, firm.		

Trench 196							
General description					Orientation		NW-SE
Trench devoid of archaeology. Consists of ploughsoil overlying natural geology of sandy clay.					Length (m)		30
					Width (m)		2.1
					Avg. depth (m)		0.35
Context No.	Type	Fill Of	Width (m)	Depth (m)	Description	Finds	Date
19600	Layer			0.35	Ploughsoil. Dark brownish grey, clayey silt, moderately compact.		
19601	Layer		2.1	0.06	Natural. Orangish brown sandy clay with occasional sub-angular stones.		
Trench 197							
General description					Orientation		E-W
Trench devoid of archaeology. Consists of ploughsoil overlying natural geology of sandy clay					Length (m)		30
					Width (m)		2.1
					Avg. depth (m)		0.35
Context No.	Type	Fill Of	Width (m)	Depth (m)	Description	Finds	Date
19700	Layer			0.35	Ploughsoil. Dark brownish grey, clayey silt, moderately compact.		
19701	Layer				Natural. Orangish brown, sandy clay with gravelly patches, firm.		
Trench 198							
General description					Orientation		N-S
Trench revealed one ditch. Two natural features. Consists of ploughsoil and subsoil overlying natural geology of sandy clay.					Length (m)		20
					Width (m)		2.1
					Avg. depth (m)		0.37
Context No.	Type	Fill Of	Width (m)	Depth (m)	Description	Finds	Date
19800	Layer			0.31	Ploughsoil. Dark brownish grey, clayey silt, moderately compact.		
19801	Layer			0.06	Subsoil. Plough soil mixed with yellowish orange sandy clay with occasional sub-angular stones.		

19802	Layer				Natural. Yellowish orange sandy clay with occasional sub-angular stones.		
19803	Cut		0.4	0.19	Ditch		
19804	Fill	19803	0.4	0.19	Primary Fill. Greyish orange, sandy silt, soft.	Nail	
19805	Cut		0.65	0.12	Natural Feature. Dark brown orangish, sandy clay, firm. Possible tree throw.		
19806	Cut		0.44	0.03	Natural Feature. Brown orangish, clayey sand, soft. Possible tree throw.		

Trench 199

General description					Orientation		E-W
Trench devoid of archaeology. Consists of ploughsoil and subsoil overlying natural geology of sandy clay.					Length (m)		30
					Width (m)		2.1
					Avg. depth (m)		0.35

Context No.	Type	Fill Of	Width (m)	Depth (m)	Description	Finds	Date
19900	Layer			0.28	Ploughsoil. Dark brownish grey, clayey silt, moderately compact.		
19901	Layer			0.07	Subsoil. Light brownish orange, clayey silt, firm.		
19902	Layer				Natural. Orangish brown, sandy clay with gravelly patches, firm.		

Trench 200

General description					Orientation		N-S
Trench devoid of archaeology. Consists of ploughsoil and subsoil overlying natural geology of sandy clay.					Length (m)		20
					Width (m)		2.1
					Avg. depth (m)		0.38

Context No.	Type	Fill Of	Width (m)	Depth (m)	Description	Finds	Date
20000	Layer			0.34	Ploughsoil. Dark brownish grey, clayey silt, moderately compact.		
20001	Layer			0.04	Subsoil. Light brownish orange, clayey silt, firm.		
20002	Layer				Natural. Orangish brown, sandy clay		

					with gravelly patches, firm		
--	--	--	--	--	-----------------------------	--	--

Trench 201							
General description					Orientation		E-W
Trench devoid of archaeology. Consists of ploughsoil and subsoil overlying natural geology of sandy clay.					Length (m)		30
					Width (m)		2.1
					Avg. depth (m)		0.38
Context No.	Type	Fill Of	Width (m)	Depth (m)	Description	Finds	Date
20100	Layer			0.32	Ploughsoil. Dark brownish grey, clayey silt, moderately compact.		
20101	Layer			0.06	Subsoil. Light brownish orange, clayey silt, firm.		
20102	Layer				Natural. Orangish brown, sandy clay with gravelly patches, firm.		

Trench 202							
General description					Orientation		W-E
Trench devoid of archaeology. Consists of ploughsoil overlying natural geology of sandy clay.					Length (m)		30
					Width (m)		2.1
					Avg. depth (m)		0.34
Context No.	Type	Fill Of	Width (m)	Depth (m)	Description	Finds	Date
20200	Layer			0.34	Ploughsoil. Dark brownish grey, clayey silt, moderately compact.		
20201	Layer				Natural. Orangish brown sandy clay with occasional sub-angular stones.		

Trench 203							
General description					Orientation		N-S
Trench devoid of archaeology. Consists of ploughsoil and subsoil overlying natural geology of sandy clay.					Length (m)		30
					Width (m)		2.1
					Avg. depth (m)		0.33
Context No.	Type	Fill Of	Width (m)	Depth (m)	Description	Finds	Date
20300	Layer			0.29	Ploughsoil. Dark brownish grey, clayey silt, moderately compact.		

20301	Layer			0.04	Subsoil. Mid orangish brown sandy clay with occasional sub-angular stones.		
20302	Layer				Natural. Orangish brown sandy clay with occasional sub-angular stones.		

Trench 204

General description						Orientation		E-W
Trench devoid of archaeology. Three natural features including a pond. Consists of ploughsoil overlying natural geology of clayey sand.						Length (m)		30
						Width (m)		2.1
						Avg. depth (m)		0.3
Context No.	Type	Fill Of	Width (m)	Depth (m)	Description	Finds	Date	
20400	Layer			0.3	Ploughsoil. Dark brownish grey, clayey silt, moderately compact.			
20401	Layer				Natural. Brownish yellow clayey sand with occasional sub-angular stones.			
20402	Cut		0.78	0.07	Natural Feature. Greyish orange, sandy clay, firm. Possible hollow or tree throw.			
20403	Cut		0.4	0.14	Natural Feature/ditch. Mid brownish orange, sandy clay, firm. Animal burrows.			

Trench 205

General description						Orientation		N-S
Trench revealed one pit. Two natural features. Consists of ploughsoil and subsoil overlying natural geology of clayey sand.						Length (m)		30
						Width (m)		2.1
						Avg. depth (m)		0.38
Context No.	Type	Fill Of	Width (m)	Depth (m)	Description	Finds	Date	
20500	Layer			0.33	Ploughsoil. Dark brownish grey, clayey silt,			
20501	Layer			0.05	Subsoil. Light brownish orange, clayey silt.			
20502	Layer				Natural. Orangish brown, clayey sand, soft to			

					moderately compact.		
20503	Cut		0.3	0.06	Pit		
20504	Fill	20503	0.3	0.06	Primary Fill		
20505	Cut				Natural Feature. Possible tree throw		
20506	Cut				Natural Feature. Rooting		

Trench 206

General description	Orientation	E-W
Trench revealed one ditch. Two natural features. Consists of ploughsoil and subsoil overlying natural geology of clayey sand.	Length (m)	30
	Width (m)	2.1
	Avg. depth (m)	0.4

Context No.	Type	Fill Of	Width (m)	Depth (m)	Description	Finds	Date
20600	Layer			0.35	Ploughsoil. Dark brownish grey, clayey silt, moderately compact.		
20601	Layer			0.05	Subsoil. Light brownish orange, clayey silt, firm.		
20602	Layer				Natural. Orangish brown, clayey gravelly sand, soft to moderately compact.		
20603	Cut				Natural Feature. Brownish orange, sandy silt, soft.		
20604	Cut		1.52	0.53	Ditch		
20605	Fill	20604	0.75	0.14	Primary Fill. Orangish grey sandy silt, soft.		
20606	Fill	20604	1.52	0.42	Secondary Fill. Greyish orange, silty sand, soft.		
20607	Cut		0.52	0.4	Natural Feature. Dark brownish black, sandy silt, soft. Possible burnt roots, tree throw.		

Trench 207

General description	Orientation	N-S
Trench devoid of archaeology. Consists of ploughsoil overlying natural geology of clayey sand.	Length (m)	30
	Width (m)	2.1
	Avg. depth (m)	0.33

Context No.	Type	Fill Of	Width (m)	Depth (m)	Description	Finds	Date
20700	Layer			0.33	Ploughsoil. Dark brownish grey,		

					clayey silt, moderately compact.		
20701	Layer				Natural. Brownish orange clayey sand with occasional sub-angular stones.		

Trench 208

General description					Orientation	E-W	
Trench revealed two ditches and one posthole. Consists of ploughsoil and subsoil overlying natural geology of clayey sand.					Length (m)	30	
					Width (m)	2.1	
					Avg. depth (m)	0.34	
Context No.	Type	Fill Of	Width (m)	Depth (m)	Description	Finds	Date
20800	Layer			0.28	Ploughsoil. Dark brownish grey, clayey silt.		
20801	Layer			0.06	Subsoil. Greyish yellow silty sand with occasional sub-angular stones.		
20802	Layer				Natural. Mottled greyish yellow and orangish brown with occasional sub-angular stones.		
20803	Cut		0.6	0.14	Ditch		
20804	Fill	20803	0.6	0.14	Secondary Fill. Light brownish orange, sandy silt with rare small stones, soft.		
20805	Cut		0.2	0.1	Posthole		
20806	Fill	20805	0.2	0.1	Primary Fill. Dark brownish grey clayey sand, soft		
20807	Cut		1.4	0.44	Ditch		
20808	Fill	20807	1.4	0.44	Secondary Fill. Greyish brown, sandy silt, compact	CBM, Fe Nail and sheet	MC15-C16

Trench 209

General description					Orientation	E-W	
Trench devoid of archaeology. Consists of ploughsoil and subsoil overlying natural geology of silty sand.					Length (m)	30	
					Width (m)	2.1	
					Avg. depth (m)	0.43	
Context No.	Type	Fill Of	Width (m)	Depth (m)	Description	Finds	Date

20900	Layer			0.34	Ploughsoil. Dark brownish grey, clayey silt.		
20901	Layer			0.09	Subsoil. Mixture of plough soil and yellowish orange silty sand with occasional sub-angular and sub-rounded stones.		
20902	Layer				Natural. Mottled yellowish orange silty sand with mid orangish yellow silty sand with occasional sub-angular and sub-rounded stones.		

Trench 210

General description		Orientation	N-S
Trench devoid of archaeology. Consists of ploughsoil and subsoil overlying natural geology of clayey sand.		Length (m)	30
		Width (m)	2.1
		Avg. depth (m)	0.36

Context No.	Type	Fill Of	Width (m)	Depth (m)	Description	Finds	Date
21000	Layer			0.3	Ploughsoil. Dark brownish grey, clayey silt, moderately compact.		
21001	Layer			0.06	Subsoil. Orangish brown clayey sand with occasional sub-angular stones.		
21002	Layer				Natural. Brownish orange clayey sand with occasional sub-angular stones.		

Trench 211

General description		Orientation	NW-SE
Trench devoid of archaeology. Consists of ploughsoil overlying natural geology of silty sand.		Length (m)	30
		Width (m)	2.1
		Avg. depth (m)	0.34

Context No.	Type	Fill Of	Width (m)	Depth (m)	Description	Finds	Date
21100	Layer			0.34	Ploughsoil. Dark brown greyish, clayey silt.		
21101	Layer				Natural. Mottled yellowish orange and mid orangish yellow silty sand		

					with occasional sub-angular and sub-rounded stones.		
--	--	--	--	--	---	--	--

Trench 212

General description					Orientation		E-W
Trench devoid of archaeology. Consists of ploughsoil and subsoil overlying natural geology of sandy clay.					Length (m)		30
					Width (m)		2.1
					Avg. depth (m)		0.38
Context No.	Type	Fill Of	Width (m)	Depth (m)	Description	Finds	Date
21200	Layer			0.32	Ploughsoil. Dark brownish grey, clayey silt.		
21201	Layer			0.06	Subsoil. Plough soil mixed with brownish orange sandy clay with gravel throughout.		
21202	Layer				Natural. Brownish orange sandy clay with gravel throughout.		

Trench 213

General description					Orientation		NE-SW
Trench devoid of archaeology. Consists of ploughsoil and subsoil overlying natural geology of sandy clay.					Length (m)		30
					Width (m)		2.1
					Avg. depth (m)		0.31
Context No.	Type	Fill Of	Width (m)	Depth (m)	Description	Finds	Date
21300	Layer			0.25	Ploughsoil. Dark brownish grey, clayey silt.		
21301	Layer			0.06	Subsoil. Yellowish orange sandy clay with occasional sub-angular stones.		
21302	Layer				Natural. Yellowish orange sandy clay with occasional sub-angular stones.		

Trench 214

General description					Orientation		NE-SW
Trench revealed one ditch. Consists of ploughsoil and subsoil overlying natural geology of silty sand.					Length (m)		30
					Width (m)		2.1
					Avg. depth (m)		0.39
Context No.	Type	Fill Of	Width (m)	Depth (m)	Description	Finds	Date

21400	Layer			0.32	Ploughsoil. Dark brownish grey, clayey silt.		
21401	Layer			0.07	Subsoil. Plough soil mixed with brownish orange silty sand with occasional sub-angular stones.		
21402	Layer				Natural. Brownish orange silty sand with occasional sub-angular stones.		
21403	Cut		1.7	0.45	Ditch		
21404	Fill	21403	1.7	0.45	Secondary Fill. Orangish brown, silty sand.	Pot, CBM, Glass	AD 1720-1780

Trench 215

General description	Orientation	E-W
Trench devoid of archaeology. Consists of ploughsoil and subsoil overlying natural geology of sandy clay.	Length (m)	30
	Width (m)	2.1
	Avg. depth (m)	0.41

Context No.	Type	Fill Of	Width (m)	Depth (m)	Description	Finds	Date
21500	Layer			0.35	Ploughsoil. Dark brownish grey, clayey silt.		
21501	Layer			0.06	Subsoil. Mottled; yellowish orange sandy clay with occasional sub-angular stones.		
21502	Layer				Natural. Yellowish orange sandy clay with occasional sub-angular stones.		

Trench 216

General description	Orientation	NE-SW
Trench devoid of archaeology. Consists of ploughsoil and subsoil overlying natural geology of sandy clay.	Length (m)	30
	Width (m)	2.1
	Avg. depth (m)	0.32

Context No.	Type	Fill Of	Width (m)	Depth (m)	Description	Finds	Date
21600	Layer			0.26	Ploughsoil. Dark brownish grey, clayey silt, moderately compact.		
21601	Layer			0.06	Subsoil. Mottled yellowish orange sandy clay with		

					occasional sub-angular stones.		
21602	Layer				Natural. Yellowish orange sandy clay with occasional sub-angular stones.		

Trench 217

General description					Orientation	N-S
Trench devoid of archaeology. Consists of ploughsoil and subsoil overlying natural geology of sandy clay.					Length (m)	30
					Width (m)	2.1
					Avg. depth (m)	0.43

Context No.	Type	Fill Of	Width (m)	Depth (m)	Description	Finds	Date
21700	Layer			0.4	Ploughsoil. Dark brownish grey, clayey silt, moderately.		
21701	Layer			0.03	Subsoil. Mottled yellowish orange sandy clay with occasional sub-angular stones.		
21702	Layer				Natural. Yellowish orange sandy clay with occasional sub-angular stones.		

Trench 218

General description					Orientation	
Not required					Length (m)	
					Width (m)	
					Avg. depth (m)	

Context No.	Type	Fill Of	Width (m)	Depth (m)	Description	Finds	Date
-------------	------	---------	-----------	-----------	-------------	-------	------

Trench 219

General description					Orientation	NW-SE
Trench devoid of archaeology. Consists of ploughsoil and subsoil overlying natural geology of clayey sand.					Length (m)	30
					Width (m)	21
					Avg. depth (m)	0.4

Context No.	Type	Fill Of	Width (m)	Depth (m)	Description	Finds	Date
21900	Layer			0.36	Ploughsoil. Dark brownish grey, clayey silt.		
21901	Layer			0.04	Subsoil. Light brownish orange, clayey silt.		
21902	Layer				Natural. Orangish brown, mainly		

					clayey sand with clayey gravelly patches.		
Trench 220							
General description					Orientation		N-S
Trench devoid of archaeology. Consists of ploughsoil and subsoil overlying natural geology of sandy clay.					Length (m)		20
					Width (m)		2.1
					Avg. depth (m)		0.43
Context No.	Type	Fill Of	Width (m)	Depth (m)	Description	Finds	Date
22000	Layer			0.36	Ploughsoil. Dark brownish grey, clayey silt.		
22001	Layer			0.07	Subsoil. Light brownish orange, clayey silt.		
22002	Layer				Natural. Orangish brown, sandy clay with gravelly patches.		
Trench 221							
General description					Orientation		E-W
Trench devoid of archaeology. Consists of ploughsoil and subsoil overlying natural geology of sandy clay.					Length (m)		30
					Width (m)		2.1
					Avg. depth (m)		0.43
Context No.	Type	Fill Of	Width (m)	Depth (m)	Description	Finds	Date
22100	Layer			0.36	Ploughsoil. Dark brownish grey, clayey silt.		
22101	Layer			0.07	Subsoil. Light brownish orange, clayey silt.		
22102	Layer				Natural. Orangish brown, sandy clay with gravelly patches.		
Trench 222							
General description					Orientation		N-S
Trench devoid of archaeology. Consists of ploughsoil and subsoil overlying natural geology of sandy clay.					Length (m)		20
					Width (m)		2.1
					Avg. depth (m)		0.42
Context No.	Type	Fill Of	Width (m)	Depth (m)	Description	Finds	Date
22200	Layer			0.36	Ploughsoil. Dark brownish grey, clayey silt, moderately compact.		

22201	Layer			0.06	Subsoil. Light brownish orange, clayey silt.		
22202	Layer				Natural. Orangish brown, sandy clay with moderate gravels.		
22203	Cut				Natural Feature. Dark brownish black, clayey silt fill.		

Trench 223

General description					Orientation		E-W
Trench devoid of archaeology. Consists of ploughsoil and subsoil overlying natural geology of sandy clay.					Length (m)		30
					Width (m)		2.1
					Avg. depth (m)		0.43
Context No.	Type	Fill Of	Width (m)	Depth (m)	Description	Finds	Date
22300	Layer			0.37	Ploughsoil. Dark brownish grey, clayey silt.		
22301	Layer			0.06	Subsoil. Light brownish orange, clayey silt.		
22302	Layer				Natural. Mid orangish brown, sandy clay with gravelly patches.		

Trench 224

General description					Orientation		N-S
Trench revealed one ditch and two gullies. Consists of ploughsoil and subsoil overlying natural geology of sandy clay.					Length (m)		20
					Width (m)		2.1
					Avg. depth (m)		0.43
Context No.	Type	Fill Of	Width (m)	Depth (m)	Description	Finds	Date
22400	Layer			0.35	Ploughsoil. Dark brownish grey, clayey silt.		
22401	Layer			0.08	Subsoil. Light brownish orange, clayey silt		
22402	Layer				Natural. Orangish brown, sandy clay with gravelly patches.		
22403	Cut		1.22		Ditch		
22404	Fill	22403	1.22		Primary Fill. Light yellowish grey, sandy clay		
22405	Fill	22403	0.96		Secondary Fill. Dark brownish grey silty clay	Pot Clay Pipe,	c 1830-1925

						Fe, Glass	
22406	Cut		0.34	0.16	Ditch. Shallow gully		
22407	Fill	22406	0.34	0.16	Primary Fill. Light blueish grey, silty clay		
22408	Cut		0.6	0.2	Ditch		
22409	Fill	22408	0.6	0.2	Primary Fill. Light blueish grey, sandy clay, moderately compact.		

Trench 225

General description						Orientation	E-W
Trench devoid of archaeology. Consists of ploughsoil and subsoil overlying natural geology of sandy clay.						Length (m)	30
						Width (m)	2.1
						Avg. depth (m)	0.46
Context No.	Type	Fill Of	Width (m)	Depth (m)	Description	Finds	Date
22500	Layer			0.36	Ploughsoil. Dark brownish grey, clayey silt		
22501	Layer			0.1	Subsoil. Light brownish orange, clayey silt		
22502	Layer				Natural. Orange brown, sandy clay with gravelly patches, firm.		

Trench 226

General description						Orientation	N-S
Trench devoid of archaeology. Consists of ploughsoil and subsoil overlying natural geology of sandy clay.						Length (m)	20
						Width (m)	2.1
						Avg. depth (m)	0.38
Context No.	Type	Fill Of	Width (m)	Depth (m)	Description	Finds	Date
22600	Layer			0.32	Ploughsoil. Dark brownish grey, clayey silt		
22601	Layer			0.06	Subsoil. Light brownish orange, clayey silt.		
22602	Layer				Natural. Orange brown, sandy clay.		
22603	Cut		0.5	0.22	Natural Feature. Mottled mid grey with occasional greyish brown patches and burnt roots.		

Trench 227

General description						Orientation	W-E
Consists of ploughsoil and subsoil overlying natural geology of clayey sand. Trench contains one natural layer.						Length (m)	30
						Width (m)	2.1
						Avg. depth (m)	0.46
Context No.	Type	Fill Of	Width (m)	Depth (m)	Description	Finds	Date
22700	Layer			0.36	Ploughsoil. Dark brownish grey, clayey silt.		
22701	Layer			0.1	Subsoil. Light brownish orange, clayey silt, firm		
22702	Layer				Natural. Orangish brown, clayey sand.		
22703	Layer		3.4		Other Layer. Brownish grey, sandy silt. Possible alluvial deposit in natural hollow		
Trench 228							
General description						Orientation	N-S
Consists of ploughsoil and subsoil overlying natural geology of clayey sand. Trench contains one natural layer.						Length (m)	20
						Width (m)	2.1
						Avg. depth (m)	0.5
Context No.	Type	Fill Of	Width (m)	Depth (m)	Description	Finds	Date
22800	Layer			0.39	Ploughsoil. Dark brownish grey, clayey silt.		
22801	Layer			0.11	Subsoil. Light brownish orange, clayey silt.		
22802	Layer				Natural. Orange brown, clayey sand with sandy patches.		
22803	Layer		4.6		Other Layer. Dark brownish grey, sandy silt, soft. Alluvial deposit in natural hollow, possibly a pond.		
Trench 229							
General description						Orientation	E-W
Trench revealed one gully. Consists of ploughsoil and subsoil overlying natural geology of sandy clay.						Length (m)	30
						Width (m)	2.1
						Avg. depth (m)	0.48
Context No.	Type	Fill Of	Width (m)	Depth (m)	Description	Finds	Date
22900	Layer			0.38	Ploughsoil. Dark brownish grey, clayey silt.		
22901	Layer			0.1	Subsoil		

22902	Layer				Natural. Orangish brown, sandy clay with gravelly patches.		
22903	Cut		0.35	0.09	Ditch		
22904	Fill	22903	0.35	0.09	Primary Fill. Light blueish grey, silty clay		
Trench 230							
General description					Orientation	N-S	
Trench revealed one gully. Consists of ploughsoil and subsoil overlying natural geology of sandy clay.					Length (m)	20	
					Width (m)	2.1	
					Avg. depth (m)	0.45	
Context No.	Type	Fill Of	Width (m)	Depth (m)	Description	Finds	Date
23000	Layer			0.36	Ploughsoil. Dark brownish grey, clayey silt.		
23001	Layer			0.09	Subsoil. Light brownish orange, clayey silt.		
23002	Layer				Natural. Orangish brown, sandy clay with gravelly patches.		
23003	Unexcavated feature				Ditch. same as [22903] in trench 229		
23004	Cut				Natural Feature.		
Trench 231							
General description					Orientation	E-W	
Trench revealed one ditch. Consists of ploughsoil and subsoil overlying natural geology of sandy clay.					Length (m)	30	
					Width (m)	2.1	
					Avg. depth (m)	0.46	
Context No.	Type	Fill Of	Width (m)	Depth (m)	Description	Finds	Date
23100	Layer			0.36	Ploughsoil. Dark brownish grey sandy silt.		
23101	Layer			0.1	Subsoil. Light brownish orange, clayey silt.		
23102	Layer				Natural. Orange brown, sandy clay.		
23103	Cut		1.9		Ditch. Not bottomed.		
23104	Fill	23103	1.9		Primary Fill. Orangish brown sandy silt.		
23105	Fill	23103	1.3		Deliberate Backfill. Dark brownish grey sandy silt		

Trench 232							
General description					Orientation		NE-SW
Trench devoid of archaeology. Consists of ploughsoil and subsoil overlying natural geology of sandy clay. Possible natural pond.					Length (m)		30
					Width (m)		2.1
					Avg. depth (m)		0.44
Context No.	Type	Fill Of	Width (m)	Depth (m)	Description	Finds	Date
23200	Layer			0.36	Ploughsoil. Dark brownish grey, clayey silt.		
23201	Layer			0.08	Subsoil. Light brownish orange, clayey silt.		
23202	Layer				Natural. Orange reddish/brownish, sandy clay with some gravel inclusions.		
23203	Layer		15		Other Layer. Possible pond.		
Trench 233							
General description					Orientation		E-W
Trench devoid of archaeology. Consists of ploughsoil and subsoil overlying natural geology of sandy clay.					Length (m)		30
					Width (m)		2.1
					Avg. depth (m)		0.32
Context No.	Type	Fill Of	Width (m)	Depth (m)	Description	Finds	Date
23300	Layer			0.25	Ploughsoil. Dark brownish grey, clayey silt, moderately.		
23301	Layer			0.07	Subsoil. Brownish orange sandy clay with occasional sub-angular stones		
23302	Layer				Natural. Brownish orange sandy clay with occasional sub-angular stones and patches of yellow sand.		
23303	Cut		1.45	0.33	Natural Feature.		
Trench 234							
General description					Orientation		N-S
Trench devoid of archaeology. Consists of ploughsoil and subsoil overlying natural geology of sandy clay.					Length (m)		30
					Width (m)		2.1
					Avg. depth (m)		0.37
Context No.	Type	Fill Of	Width (m)	Depth (m)	Description	Finds	Date

23400	Layer			0.3	Ploughsoil. Dark brownish grey, clayey silt.		
23401	Layer			0.07	Subsoil. Orangish brown sandy clay with occasional sub-angular stones.		
23402	Layer				Natural. Brownish orange sandy clay with occasional sub-angular stones.		

Trench 235

General description

Trench revealed two ditches, one gully and three postholes. Consists of ploughsoil and subsoil overlying natural geology of sandy clay.

Orientation

E-W

Length (m)

30

Width (m)

2.1

Avg. depth (m)

0.36

Context No.	Type	Fill Of	Width (m)	Depth (m)	Description	Finds	Date
23500	Layer			0.3	Ploughsoil. Dark brownish grey, clayey silt.		
23501	Layer			0.06	Subsoil. Orangish brown sandy clay with occasional sub-angular stones.		
23502	Layer				Natural. Brownish orange sandy clay with occasional sub-angular stones.		
23503	Cut		0.31	0.07	Pit		
23504	Fill	23503	0.31	0.07	Primary Fill. Orangish grey silty clay, occasional charcoal flakes		
23505	Cut		0.18	0.16	Pit		
23506	Fill	23505	0.18	0.16	Primary Fill. Orangish grey silty clay		
23507	Cut		0.4	0.17	Ditch		
23508	Fill	23507	0.4	0.17	Primary Fill. Greyish orange silty clay		
23509	Cut		0.31	0.08	Pit		
23510	Fill	23509	0.31	0.08	Primary Fill. Mottled greyish orange silty clay		
23511	Cut				Natural Feature. Greyish orange, silty clay.		
23512	Cut				Natural Feature. Brownish grey silty clay.		
23513	Cut		0.72	0.26	Ditch		
23514	Fill	23513	0.72	0.26	Primary Fill. Moderately	Pot, Fe	AD 43-70

					compact greyish orange silty clay.		
23515	Cut		1.64	0.54	Ditch. Not bottomed		
23516	Fill	23515	0.36		Primary Fill. Moderately compact greyish brown silty clay.		
23517	Fill			0.54	Secondary Fill. Moderately compact greyish yellow silty clay.	Flint, CBM	C19th

Trench 236

General description	Orientation	N-S
Trench devoid of archaeology. Consists of ploughsoil and subsoil overlying natural geology of sandy clay.	Length (m)	30
	Width (m)	2.1
	Avg. depth (m)	0.46

Context No.	Type	Fill Of	Width (m)	Depth (m)	Description	Finds	Date
23600	Layer			0.38	Ploughsoil. Dark brownish grey, clayey silt.		
23601	Layer			0.08	Subsoil. Light brownish orange, clayey silt.		
23602	Layer				Natural. Orangish brown, sandy clay.		

Trench 237

General description	Orientation	E-W
Trench devoid of archaeology. Consists of ploughsoil and subsoil overlying natural geology of sandy clay.	Length (m)	30
	Width (m)	2.1
	Avg. depth (m)	0.45

Context No.	Type	Fill Of	Width (m)	Depth (m)	Description	Finds	Date
23700	Layer			0.36	Ploughsoil. Dark brownish grey, clayey silt.		
23701	Layer			0.09	Subsoil. Light brownish orange, clayey silt.		
23702	Layer				Natural. Orangish brown, sandy clay with gravels.		

Trench 238

General description	Orientation	N-S
Trench revealed one ditch. Consists of ploughsoil and subsoil overlying natural geology of sandy clay.	Length (m)	30
	Width (m)	2.1
	Avg. depth (m)	0.45

Context No.	Type	Fill Of	Width (m)	Depth (m)	Description	Finds	Date
-------------	------	---------	-----------	-----------	-------------	-------	------

23800	Layer			0.36	Ploughsoil. Dark brownish grey, clayey silt, moderately compact.		
23801	Layer			0.09	Subsoil. Light brownish orange, clayey silt.		
23802	Layer				Natural. Orange brown, sandy clay with moderate gravels.		
23803	Cut		0.4	0.16	Ditch		
23804	Fill	23803	0.4	0.16	Primary Fill. Orangish yellow silty clay	Clay Pipe, Fe Nail, Cu Alloy, CBM,	C19th-20th
23805	Cut		0.32	0.03	Natural Feature. Light yellowish brown silty clay		
23806	Cut		1.51	0.36	Natural Feature. Possible tree throw, more than 1.51m width (just part visible in trench).		
23807	Cut		0.23	0.03	Natural Feature. Dark brownish black, sandy silt, soft.		

Trench 239

General description	Orientation	E-W
Trench devoid of archaeology. Consists of ploughsoil and subsoil overlying natural geology of sandy clay.	Length (m)	30
	Width (m)	2.1
	Avg. depth (m)	0.35

Context No.	Type	Fill Of	Width (m)	Depth (m)	Description	Finds	Date
23900	Layer			0.25	Ploughsoil. Dark brownish grey, clayey silt, moderately compact.		
23901	Layer			0.1	Subsoil. Mid orangish brown sandy clay with occasional sub-angular stones.		
23902	Layer				Natural. Mid brownish orange sandy clay with occasional sub-angular stones.		

Trench 240

General description						Orientation	E-W
Trench revealed two postholes and two pits. Consists of ploughsoil and subsoil overlying natural geology of sandy clay.						Length (m)	28
						Width (m)	2.1
						Avg. depth (m)	0.5
Context No.	Type	Fill Of	Width (m)	Depth (m)	Description	Finds	Date
24000	Layer			0.38	Ploughsoil		
24001	Layer			0.12	Subsoil. Mid orangish brown sandy clay with occasional sub-angular stones.		
24002	Layer				Natural. Mid brownish orange sandy clay with gravel throughout. Occasionally gives out to brownish yellow clayey sand patches.		
24003	Cut		0.76	0.15	Pit		
24004	Fill	24003	0.76	0.15	Primary Fill. Mid greyish brown/orange, clayey silt, moderately compact. Rare charcoal.		
24005	Cut		0.28	0.1	Pit		
24006	Fill	24005	0.28	0.1	Primary Fill. Dark brownish grey, clayey silt with charcoal, moderately compact.	<S1>	
24007	Cut		0.21	0.1	Posthole		
24008	Fill	24007	0.21	0.1	Other Fill. Dark brownish grey, clayey silt with charcoal, moderately compact.		
24009	Cut		0.54	0.16	Pit		
24010	Fill	24009	0.54	0.16	Other Fill. Mid greyish orange, clayey sand, soft. Rare small stones		
24011	Cut		0.86	0.18	Natural Feature. Light orangish brown, clayey sand, firm.		
Trench 241							
General description						Orientation	N-S
						Length (m)	30

Trench devoid of archaeology. Consists of ploughsoil and subsoil overlying natural geology of sandy clay.						Width (m)	2.1
						Avg. depth (m)	0.31
Context No.	Type	Fill Of	Width (m)	Depth (m)	Description	Finds	Date
24100	Layer			0.24	Ploughsoil. Dark brownish grey, clayey silt, moderately compact.		
24101	Layer			0.07	Subsoil. Mid brownish orange sandy clay with occasional sub-angular stones.		
24102	Layer				Natural. Mid brownish orange sandy clay with gravel throughout.		
24103	Cut				Natural Feature. Mid greyish-brown, Clayey silt, Soft fill		
24104	Cut				Natural Feature. Mid greyish black, Soft, clayey silt fill		
24105	Cut				Natural Feature. Light Yellowish Grey, soft clayey silt fill		

Trench 242

General description						Orientation	E-W
Trench devoid of archaeology. Three natural features. Consists of ploughsoil and subsoil overlying natural geology of sandy clay.						Length (m)	30
						Width (m)	2
						Avg. depth (m)	0.42
Context No.	Type	Fill Of	Width (m)	Depth (m)	Description	Finds	Date
24200	Layer			0.34	Ploughsoil. Mid greyish brown, silty clay, friable		
24201	Layer			0.08	Subsoil. Dark grey brown, silty clay, firm		
24202	Layer				Natural. Mid brownish orange, sandy clay, firm.		
24203	Cut				Other Cut. Drain. Mid greyish brown, soft, clayey silt fill.		
24204	Cut				Natural Feature. Light yellowish grey, soft silty clay fill.		
24205	Cut				Natural Feature. Light Yellowish Grey, soft, Clayey Silt Fill		

Trench 243							
General description					Orientation		N-S
Trench devoid of archaeology. Consists of ploughsoil and subsoil overlying natural geology of sandy clay.					Length (m)		30
					Width (m)		2
					Avg. depth (m)		0.45
Context No.	Type	Fill Of	Width (m)	Depth (m)	Description	Finds	Date
24300	Layer			0.4	Ploughsoil. Mid grey brown, silty clay, friable		
24301	Layer			0.05	Subsoil. Dark grey brown, silty clay, firm		
24302	Layer				Natural. Mid brown orange, sandy clay, firm		
Trench 244							
General description					Orientation		E-W
Trench devoid of archaeology. 3 natural features. Consists of ploughsoil and subsoil overlying natural geology of sandy clay.					Length (m)		30
					Width (m)		2
					Avg. depth (m)		0.41
Context No.	Type	Fill Of	Width (m)	Depth (m)	Description	Finds	Date
24400	Layer			0.37	Ploughsoil. Mid grey brown, silty clay, friable		
24401	Layer			0.04	Subsoil. Dark grey brown, silty clay, firm		
24402	Layer				Natural. Mid brown orange, sandy clay, firm		
24403	Cut		28	0.03	Natural Feature. Dark brown orangeish. Clayey silt. Soft Possible rooting		
24404	Cut		0.65	0.19	Natural Feature. Possible tree throw		
24405	Cut		0.24	0.06	Natural Feature. Mid brownish orange, clayey sand, firm.		
Trench 245							
General description					Orientation		N-S
Trench devoid of archaeology. Consists of ploughsoil and subsoil overlying natural geology of sandy clay.					Length (m)		30
					Width (m)		2.1
					Avg. depth (m)		0.37
Context No.	Type	Fill Of	Width (m)	Depth (m)	Description	Finds	Date

24500	Layer			0.3	Ploughsoil. Dark brownish grey, clayey silt, moderately compact.		
24501	Layer			0.07	Subsoil. Mid orangish brown sandy clay with occasional sub-angular stones.		
24502	Layer				Natural. Mid brownish orange sandy clay with occasional sub-angular stones and patches of mid brownish yellow sandy clay.		

Trench 246

General description						Orientation		N-S
Trench revealed one ditch and one pit. Consists of ploughsoil and subsoil overlying natural geology of sandy clay.						Length (m)		30
						Width (m)		2.1
						Avg. depth (m)		0.42

Context No.	Type	Fill Of	Width (m)	Depth (m)	Description	Findings	Date
24600	Layer			0.35	Ploughsoil. Dark brown greyish, clayey silt, moderately compact.		
24601	Layer			0.07	Subsoil. Mid orangish brown sandy clay with occasional sub-angular stones.		
24602	Layer				Natural. Mid brownish orange sandy clay with gravel throughout.		
24603	Cut		0.65	0.12	Pit		
24604	Fill	24603	0.65	0.12	Primary Fill. Dark greyish brown with yellow orange flecks, silty clay.	Fired Clay, BF, <S2>	Preh-Med
24605	Cut				Natural Feature		
24606	Cut		1.2		Ditch		
24607	Fill	24606	1.2		Primary Fill. Mixed blue grey and yellow, silty clay.		

Trench 247

General description						Orientation		E-W
Trench revealed one ditch. Consists of ploughsoil and subsoil overlying natural geology of sandy clay.						Length (m)		30
						Width (m)		2

						Avg. depth (m)	0.4
Context No.	Type	Fill Of	Width (m)	Depth (m)	Description	Finds	Date
24700	Layer			0.29	Ploughsoil. Mid greyish brown, silty clay, friable		
24701	Layer			0.11	Subsoil. Dark greyish brown, silty clay, firm		
24702	Layer				Natural. Mid brownish orange, silty clay, firm		
24703	Cut		0.45	0.22	Ditch		
24704	Fill	24703	0.45	0.22	Primary Fill. Mottled mid blueish and greyish orange clay		

Trench 248

General description						Orientation	N-S
Trench devoid of archaeology. Consists of ploughsoil and subsoil overlying natural geology of sandy clay						Length (m)	30
						Width (m)	2
						Avg. depth (m)	0.46

Context No.	Type	Fill Of	Width (m)	Depth (m)	Description	Finds	Date
24800	Layer			0.35	Ploughsoil. Mid greyish brown, silty clay, friable		
24801	Layer			0.11	Subsoil. Dark grey brown, silty clay, firm		
24802	Layer				Natural. Mid brown orange, silty clay, firm		

Trench 249

General description						Orientation	E-W
Trench devoid of archaeology. One natural feature. Consists of ploughsoil and subsoil overlying natural geology of sandy clay.						Length (m)	30
						Width (m)	2
						Avg. depth (m)	0.4

Context No.	Type	Fill Of	Width (m)	Depth (m)	Description	Finds	Date
24900	Layer			0.31	Ploughsoil. Mid grey brown, silty clay, friable		
24901	Layer			0.09	Subsoil. Dark greyish brown, silty clay, firm		
24902	Layer				Natural. Mid brownish orange, silty clay, firm		
24903	Cut				Natural Feature. Mid blackish brown, soft, silty clay.		

Trench 250							
General description					Orientation		N-S
Trench devoid of archeology. Consists of ploughsoil and subsoil overlying natural geology of sandy clay.					Length (m)		30
					Width (m)		2.1
					Avg. depth (m)		0.39
Context No.	Type	Fill Of	Width (m)	Depth (m)	Description	Finds	Date
25000	Layer			0.32	Ploughsoil. Dark brownish grey, clayey silt, moderately compact.		
25001	Layer			0.07	Subsoil. Mid orangish brown sandy clay with occasional sub-angular stones.		
25002	Layer				Natural. Mid brownish orange sandy clay with occasional sub-angular stones.		

Trench 251							
General description					Orientation		E-W
Trench revealed two ditches and one natural feature. Consists of ploughsoil and subsoil overlying natural geology of sandy clay.					Length (m)		30
					Width (m)		2.1
					Avg. depth (m)		0.37
Context No.	Type	Fill Of	Width (m)	Depth (m)	Description	Finds	Date
25100	Layer			0.3	Ploughsoil. Dark brownish grey, clayey silt, moderately compact.		
25101	Layer			0.07	Subsoil. Mid orangish brown sandy clay with occasional sub-angular stones.		
25102	Layer				Natural. Mid brownish orange sandy clay with occasional sub-angular stones.		
25103	Cut		0.79	0.52	Ditch		
25104	Fill	25103	0.25	0.42	Primary Fill. Dark reddish grey, silty clay	Pot	c 1850-1950
25105	Fill	25103	0.3	0.46	Primary Fill. Dark reddish grey silty clay		
25106	Fill	25103	0.34	0.47	Deliberate Backfill. Dark blackish grey clay.		

25107	Cut		0.47	0.24	Ditch. Possible ditch terminus		
25108	Fill	25107	0.47	0.24	Secondary Fill. Mid orangey grey clay rare sub angular small stones		
25109	Cut		0.23	0.15	Natural Feature. Blackish brown deposit.		

Trench 252

General description					Orientation	E-W
Trench devoid of archaeology. One natural feature. Consists of ploughsoil and subsoil overlaying natural geology of sandy clay.					Length (m)	30
					Width (m)	2.1
					Avg. depth (m)	0.38

Context No.	Type	Fill Of	Width (m)	Depth (m)	Description	Finds	Date
25200	Layer			0.28	Ploughsoil. Dark brownish grey, clayey silt, moderately compact.		
25201	Layer			0.1	Subsoil. Mid orangish brown sandy clay with occasional sub-angular stones.		
25202	Layer				Natural. Mid brownish orange sandy clay with occasional sub-angular stones.		
25203	Cut		0.4	0.18	Natural Feature. Mid greyish brown clayey silt.		
25204	Void						

Trench 253

General description					Orientation	N-S
Trench devoid of archaeology. One natural feature. Consists of ploughsoil and subsoil overlying natural geology of silty clay.					Length (m)	30
					Width (m)	2
					Avg. depth (m)	0.39

Context No.	Type	Fill Of	Width (m)	Depth (m)	Description	Finds	Date
25300	Layer			0.29	Ploughsoil. Mid grey brown, silty clay, friable		
25301	Layer			0.1	Subsoil. Dark grey brown, silty clay, firm		
25302	Layer				Natural. Mid brown orange, silty clay, firm		

25303	Cut		0.6	0.2	Natural Feature. Mid greyish brown clayey silt.		
Trench 254							
General description					Orientation		E-W
Trench revealed three ditches. Consists of ploughsoil and subsoil overlying natural geology of silty clay					Length (m)		30
					Width (m)		2
					Avg. depth (m)		0.4
Context No.	Type	Fill Of	Width (m)	Depth (m)	Description	Finds	Date
25400	Layer			0.31	Ploughsoil. Mid grey brown, silty clay, friable		
25401	Layer			0.09	Subsoil. Dark grey brown, silty clay, firm		
25402	Layer				Natural. Mid brown orange, silty clay, firm		
25403	Cut		1.06	0.4	Ditch		
25404	Fill	25403	1.06	0.4	Primary Fill. Mid blue grey sandy clay with yellow sand mixed in		
25405	Cut		0.68	0.49	Ditch		
25406	Fill	25405	0.68	0.49	Primary Fill. Light blue grey with some yellow mixed in. Sandy clay, single fill. Finds of pot, poss medieval	Pot	50BC-AD 70
25407	Cut		1.51		Ditch		
25408	Fill	25407	1.51		Primary Fill	CBM	C15th-16th
Trench 255							
General description					Orientation		N-S
Trench devoid of archaeology. 3 natural features. Consists of ploughsoil and subsoil overlying natural geology of silty clay.					Length (m)		30
					Width (m)		2
					Avg. depth (m)		0.38
Context No.	Type	Fill Of	Width (m)	Depth (m)	Description	Finds	Date
25500	Layer			0.31	Ploughsoil. Mid grey brown, silty clay, friable		
25501	Layer			0.07	Subsoil. Dark grey brown, silty clay, firm		
25502	Layer				Natural. Mid brown orange, silty clay, firm		
25503	Cut				Natural Feature. Rooting		

25504	Cut				Natural Feature. Rooting		
25505	Cut				Natural Feature. Rooting		
Trench 256							
General description					Orientation		NW-SE
Trench devoid of archaeology. 1 natural feature. Consists of ploughsoil and subsoil overlying natural geology of silty clay					Length (m)		30
					Width (m)		2
					Avg. depth (m)		0.35
Context No.	Type	Fill Of	Width (m)	Depth (m)	Description	Finds	Date
25600	Layer			0.28	Ploughsoil. Mid grey brown, silty clay, friable		
25601	Layer			0.07	Subsoil. Dark grey brown, silty clay, firm		
25602	Layer				Natural. Mid brown orange, silty clay, firm		
25603	Cut				Natural Feature. Possible rooting		
Trench 257							
General description					Orientation		N-S
Trench devoid of archaeology. Consists of ploughsoil and subsoil overlying natural geology of sandy clay.					Length (m)		30
					Width (m)		2.1
					Avg. depth (m)		0.46
Context No.	Type	Fill Of	Width (m)	Depth (m)	Description	Finds	Date
25700	Layer			0.36	Ploughsoil. Dark brownish grey, clayey silt, moderately compact.		
25701	Layer			0.1	Subsoil. Mid brownish orange, clayey silt, firm.		
25702	Layer				Natural. Mid orangish brown, sandy clay with gravelly patches, firm.		
Trench 258							
General description					Orientation		E-W
Trench devoid of archaeology. Consists of ploughsoil and subsoil overlying natural geology of sandy clay.					Length (m)		30
					Width (m)		2.1
					Avg. depth (m)		0.38
Context No.	Type	Fill Of	Width (m)	Depth (m)	Description	Finds	Date

25800	Layer			0.3	Ploughsoil. Mid brownish grey, clayey silt, moderately compact.		
25801	Layer			0.08	Subsoil. Light brown orangish, clayey silt, moderately compact.		
25802	Layer				Natural. Orangish brown with greyish patches, clayey sand		
25803	Cut		1.1	0.26	Natural Feature. Light grey orangish, clayey sand, moderately compact.		

Trench 259

General description					Orientation		E-W
Trench devoid of archaeology. Consists of ploughsoil and subsoil overlying natural geology of sandy clay.					Length (m)		30
					Width (m)		2.1
					Avg. depth (m)		0.36
Context No.	Type	Fill Of	Width (m)	Depth (m)	Description	Findings	Date
25900	Layer			0.32	Ploughsoil		
25901	Layer			0.04	Subsoil		
25902	Layer				Natural		
25903	Cut		2.4	0.03	Natural Feature Greyish orange, clayey sand. Possible hollow.		

Trench 260

General description					Orientation		N-S
Trench devoid of archaeology. Consists of ploughsoil and subsoil overlying natural geology of sandy clay.					Length (m)		
					Width (m)		2.1
					Avg. depth (m)		0.46
Context No.	Type	Fill Of	Width (m)	Depth (m)	Description	Findings	Date
26000	Layer			0.37	Ploughsoil		
26001	Layer			0.09	Subsoil		
26002	Layer				Natural. Orangish brown, sandy clay with some gravelly patches.		

Trench 261

General description					Orientation		E-W
					Length (m)		30

Trench devoid of archaeology. Consists of ploughsoil and subsoil overlying natural geology of sandy clay.						Width (m)	2.1
						Avg. depth (m)	0.36
Context No.	Type	Fill Of	Width (m)	Depth (m)	Description	Finds	Date
26100	Layer			0.28	Ploughsoil. Brownish grey, clayey silt.		
26101	Layer			0.08	Subsoil. Light brown orangish, clayey silt		
26102	Layer				Natural		
26103	Cut		0.26	0.11	Natural Feature. Dark greyish brown, clayey sand		
Trench 262							
General description						Orientation	NE-SW
Trench revealed two ditches. Consists of ploughsoil and subsoil overlying natural geology of sandy clay.						Length (m)	30
						Width (m)	2.1
						Avg. depth (m)	0.48
Context No.	Type	Fill Of	Width (m)	Depth (m)	Description	Finds	Date
26200	Layer			0.3	Ploughsoil		
26201	Layer			0.18	Subsoil		
26202	Layer				Natural. Orangish brown sandy clay with reddish patches.		
26203	Cut		0.55	0.34	Ditch		
26204	Fill		0.55	0.34	Primary Fill. Light sandy clay		
26205	Cut		0.53	0.26	Ditch		
26206	Fill	26205	0.53	0.26	Primary Fill. Light sandy clay		
26207	Cut				Tree Throw. Natural feature		
Trench 263							
General description						Orientation	E-W
Trench devoid of archaeology. Consists of ploughsoil and subsoil overlying natural geology of sandy clay.						Length (m)	30
						Width (m)	2.1
						Avg. depth (m)	0.34
Context No.	Type	Fill Of	Width (m)	Depth (m)	Description	Finds	Date
26300	Layer			0.27	Ploughsoil. Dark brownish grey, clayey silt		
26301	Layer			0.07	Subsoil. Orangish brown sandy clay with occasional sub-angular stones.		

26302	Layer				Natural. Brownish orange sandy clay with occasional sub-angular stones.		
26303	Cut		1.2	0.04	Natural Feature. Orangish brown, silty sand, soft. Possible tree throw.		

Trench 264

General description					Orientation	N-S	
Trench devoid of archaeology. Consists of ploughsoil and subsoil overlying natural geology of sandy clay.					Length (m)	30	
					Width (m)	2.1	
					Avg. depth (m)	0.34	
Context No.	Type	Fill Of	Width (m)	Depth (m)	Description	Finds	Date
26400	Layer			0.27	Ploughsoil. Dark brown greyish, clayey silt.		
26401	Layer			0.07	Subsoil. Orangish brown sandy clay with occasional sub-angular stones.		
26402	Layer				Natural. Brownish orange sandy clay with gravel throughout.		

Trench 265

General description					Orientation	E-W	
Trench revealed one ditch. Consists of ploughsoil and subsoil overlying natural geology of sandy clay.					Length (m)	30	
					Width (m)	2.1	
					Avg. depth (m)	0.46	
Context No.	Type	Fill Of	Width (m)	Depth (m)	Description	Finds	Date
26500	Layer			0.36	Ploughsoil		
26501	Layer			0.1	Subsoil		
26502	Layer				Natural. Orange brown, sandy clay, firm.		
26503	Cut		0.69	0.24	Ditch		
26504	Fill	26503	0.69	0.24	Secondary Fill. Greyish orange, silty sand, soft.		
26505	Cut		1.05	0.16	Natural Feature. Orangish brown with sandy grey patches, sandy clay, compact.		
26506	Cut		0.5	0.17	Natural Feature. Orangish grey, silty		

					sand, soft. Possible tree throw.		
Trench 266							
General description					Orientation	N-S	
Trench devoid of archaeology. Consists of ploughsoil and subsoil overlying natural geology of sandy clay.					Length (m)	30	
					Width (m)	2.1	
					Avg. depth (m)	0.45	
Context No.	Type	Fill Of	Width (m)	Depth (m)	Description	Finds	Date
26600	Layer			0.35	Ploughsoil		
26601	Layer			0.1	Subsoil		
26602	Layer				Natural. Orangish brown, sandy clay, firm.		
Trench 267							
General description					Orientation	E-W	
Trench revealed one ditch and two postholes. Consists of ploughsoil and subsoil overlying natural geology of sandy clay.					Length (m)	30	
					Width (m)	2.1	
					Avg. depth (m)	0.53	
Context No.	Type	Fill Of	Width (m)	Depth (m)	Description	Finds	Date
26700	Layer			0.38	Ploughsoil		
26701	Layer			0.15	Subsoil		
26702	Layer				Natural. Reddish brown, sandy clay, firm.		
26703	Cut		0.22	0.2	Posthole		
26704	Fill	26703	0.15	0.16	Primary Fill. Greyish orange silty clay, moderately compact, occasional charcoal		
26705	Fill	26703	0.2	0.08	Secondary Fill. Greyish brown silty clay		
26706	Cut		0.3	0.22	Posthole		
26707	Fill	26706	0.27	0.12	Primary Fill. Greyish orange moderately compact silty clay, occasional charcoal		
26708	Fill	26706	0.3	0.1	Secondary Fill. Greyish brown moderately compact, silty clay		
26709	Unexcavated feature		0.7		Ditch. Ditch also in trenches 262 and		

					272. Fill light greyish yellow, sandy silt		
26710	Cut				Natural Feature.		
Trench 268							
General description					Orientation	N-S	
Trench devoid of archaeology. Consists of ploughsoil and subsoil overlying natural geology of sandy clay.					Length (m)	30	
					Width (m)	2.3	
					Avg. depth (m)	0.42	
Context No.	Type	Fill Of	Width (m)	Depth (m)	Description	Finds	Date
26800	Layer			0.3	Ploughsoil. Dark brownish grey, clayey silt		
26801	Layer			0.12	Subsoil. Orangish brown sandy clay with occasional sub angular stones.		
26802	Layer				Natural. Brownish orange sandy clay with occasional sub-angular stones.		
Trench 269							
General description					Orientation	E-W	
Trench devoid of archaeology. Consists of ploughsoil and subsoil overlying natural geology of sandy clay.					Length (m)	30	
					Width (m)	2.3	
					Avg. depth (m)	0.33	
Context No.	Type	Fill Of	Width (m)	Depth (m)	Description	Finds	Date
26900	Layer			0.2	Ploughsoil. Dark brownish grey, clayey silt.		
26901	Layer			0.13	Subsoil. Orangish brown sandy clay with occasional sub angular stones.		
26902	Layer				Natural. Brownish orange sandy clay with occasional sub angular stones.		
Trench 270							
General description					Orientation	N-S	
Trench devoid of archaeology. Consists of ploughsoil and subsoil overlying natural geology of sandy clay.					Length (m)	30	
					Width (m)	2.3	
					Avg. depth (m)	0.44	

Context No.	Type	Fill Of	Width (m)	Depth (m)	Description	Finds	Date
27000	Layer			0.37	Ploughsoil. Dark brownish grey, clayey silt.		
27001	Layer			0.07	Subsoil. Mottled greyish brown loam and brownish orange sandy clay with occasional sub rounded stones.		
27002	Layer				Natural. Brownish orange sandy clay with occasional sub rounded stones.		

Trench 271

General description Trench revealed two ditches. Consists of ploughsoil and subsoil overlying natural geology of sandy clay.	Orientation	E-W
	Length (m)	30
	Width (m)	2.1
	Avg. depth (m)	0.44

Context No.	Type	Fill Of	Width (m)	Depth (m)	Description	Finds	Date
27100	Layer			0.37	Ploughsoil		
27101	Layer			0.07	Subsoil		
27102	Layer				Natural. Orangish brown, sandy clay, firm.		
27103	Cut		0.95	0.24	Ditch		
27104	Fill		0.95	0.24	Secondary Fill. Yellowish grey, soft, clayey silt		
27105	Cut		0.6	0.13	Ditch		
27106	Fill	27105	0.6	0.13	Secondary Fill. Light yellowish grey, soft, clayey silt	Pot	AD 50-270
27107	Cut				Natural Feature. Possible tree throw. Firm, light yellowish grey, silty clay fill.		

Trench 272

General description Trench revealed one ditch. Consists of ploughsoil and subsoil overlying natural geology of sandy clay.	Orientation	N-S
	Length (m)	30
	Width (m)	2.1
	Avg. depth (m)	0.44

Context No.	Type	Fill Of	Width (m)	Depth (m)	Description	Finds	Date
27200	Layer			0.36	Ploughsoil		

27201	Layer			0.08	Subsoil		
27202	Layer				Natural		
27203	Cut		0.84	0.54	Ditch		
27204	Fill	27203	0.64	0.38	Secondary Fill. Mid greyish orange, clayey sand.		
27205	Fill		0.84	0.17	Secondary Fill. Light brown orangish, clayey silt.		

Trench 273

General description	Orientation	E-W
Trench devoid of archaeology. Consists of ploughsoil and subsoil overlying natural geology of sandy clay.	Length (m)	30
	Width (m)	2.1
	Avg. depth (m)	0.38

Context No.	Type	Fill Of	Width (m)	Depth (m)	Description	Finds	Date
27300	Layer			0.33	Ploughsoil. Dark brown greyish, clayey silt.		
27301	Layer			0.05	Subsoil. Mid orange brown, sandy clay with occasional sub rounded stones		
27302	Layer				Natural. Brownish orange, compact sandy clay		
27304	Cut				Natural Feature. Reddish-grey, soft, silty clay		

Trench 274

General description	Orientation	N-S
Trench devoid of archaeology. Consists of ploughsoil and subsoil overlying natural geology of sandy clay.	Length (m)	30
	Width (m)	2.1
	Avg. depth (m)	0.36

Context No.	Type	Fill Of	Width (m)	Depth (m)	Description	Finds	Date
27400	Layer			0.31	Ploughsoil. Dark brown greyish, clayey silt.		
27401	Layer			0.05	Subsoil. Orangish brown, sandy clay, occasional sub rounded stones		
27402	Layer				Natural. Brownish orange, sandy clay		

Trench 275

General description	Orientation	E-W
	Length (m)	0.53

Trench revealed one ditch. Consists of ploughsoil and subsoil overlying natural geology of sandy clay.						Width (m)	2.3
						Avg. depth (m)	0.44
Context No.	Type	Fill Of	Width (m)	Depth (m)	Description	Finds	Date
27500	Layer			0.4	Ploughsoil. Dark brownish grey, clayey silt.		
27501	Layer			0.04	Subsoil. Orangish brown sandy clay with occasional sub angular stones.		
27502	Layer				Natural. Brownish orange sandy clay with occasional sub angular stones.		
27503	Cut		0.66	0.12	Ditch		
27504	Fill	27503	0.66	0.12	Secondary Fill. Yellowish brown silty clay		
27505	Cut		0.36	0.04	Natural Feature. Dark blackish brown silty clay, tree throw.		

Trench 276							
General description						Orientation	NE-SW
						Trench revealed three ditches. Consists of ploughsoil and subsoil overlying natural geology of sandy clay.	
Width (m)	2.3						
Avg. depth (m)	0.36						
Context No.	Type	Fill Of	Width (m)	Depth (m)	Description	Finds	Date
27600	Layer			0.26	Ploughsoil. Dark brownish grey, clayey silt, moderately compact.		
27601	Layer			0.1	Subsoil. Orangish brown sandy clay with occasional sub angular stones.		
27602	Layer				Natural. Brownish orange sandy clay with occasional sub angular stones.		
27603	Cut		0.34	0.14	Ditch		
27604	Fill	27603	0.34	0.14	Secondary Fill. Greyish brown silty clay		
27605	Cut		0.6	0.2	Natural Feature. Natural feature.		

27606	Cut		0.27	0.03	Natural Feature. Burnt tree throw hole.		
27607	Cut		0.37	0.16	Ring ditch		
27608	Fill	27607	0.37	0.16	Secondary Fill. Brownish grey silty clay.		
27609	Cut		0.49	0.11	Ring ditch		
27610	Fill	27609	0.49	0.11	Secondary Fill. Greyish brown silty clay.		

Trench 277

General description	Orientation	W-E
Trench revealed one ditch. Consists of ploughsoil and subsoil overlying natural geology of sandy clay.	Length (m)	30
	Width (m)	2.3
	Avg. depth (m)	0.41

Context No.	Type	Fill Of	Width (m)	Depth (m)	Description	Finds	Date
27700	Layer			0.35	Ploughsoil. Dark brownish grey, clayey silt, moderately compact.		
27701	Layer			0.06	Subsoil. Orangish brown sandy clay with occasional sub angular stones.		
27702	Layer				Natural. Brownish orange sandy clay with occasional sub angular stones.		
27703	Cut		0.46	0.5	Ditch. bottom not reached		
27704	Fill	27703	0.46	0.5	Secondary Fill. Light bluish grey mottled with oranges brown silty clay.	Pot	AD70-160

Trench 278

General description	Orientation	E-W
Trench devoid of archaeology. Consists of ploughsoil and subsoil overlying natural geology of sandy clay.	Length (m)	30
	Width (m)	2.1
	Avg. depth (m)	0.45

Context No.	Type	Fill Of	Width (m)	Depth (m)	Description	Finds	Date
27800	Layer			0.38	Ploughsoil. Dark brownish grey, clayey silt, moderately compact.		

27801	Layer			0.07	Subsoil. Orangish brown, sandy clay.		
27802	Layer				Natural. Brownish orange, compact sandy clay		
Trench 279							
General description					Orientation		N-S
Trench devoid of archaeology. Consists of ploughsoil and subsoil overlying natural geology of silty clay.					Length (m)		30
					Width (m)		2
					Avg. depth (m)		0.4
Context No.	Type	Fill Of	Width (m)	Depth (m)	Description	Finds	Date
27900	Layer			0.26	Ploughsoil. Greyish brown, silty clay		
27901	Layer			0.14	Subsoil. Dark greyish brown, silty clay		
27902	Layer				Natural. Mid brownish orange, silty clay, firm		
Trench 280							
General description					Orientation		N-S
Trench devoid of archaeology. Consists of ploughsoil and subsoil overlying natural geology of silty clay.					Length (m)		30
					Width (m)		2
					Avg. depth (m)		0.39
Context No.	Type	Fill Of	Width (m)	Depth (m)	Description	Finds	Date
28000	Layer			0.32	Ploughsoil. Greyish brown, silty clay		
28001	Layer			0.07	Subsoil. Dark greyish brown, silty clay		
28002	Layer				Natural. Brownish orange, silty clay		
Trench 281							
General description					Orientation		E-W
Trench devoid of archaeology. Consists of ploughsoil and subsoil overlying natural geology of silty clay					Length (m)		30
					Width (m)		2
					Avg. depth (m)		0.39
Context No.	Type	Fill Of	Width (m)	Depth (m)	Description	Finds	Date
28100	Layer			0.27	Ploughsoil. Greyish brown, silty clay		

28101	Layer			0.12	Subsoil. Dark grey brown, silty clay		
28102	Layer				Natural. Brown orange, silty clay		
Trench 282							
General description					Orientation		E-W
Trench devoid of archaeology. Consists of ploughsoil and subsoil overlying natural geology of silty clay					Length (m)		30
					Width (m)		2
					Avg. depth (m)		0.46
Context No.	Type	Fill Of	Width (m)	Depth (m)	Description	Finds	Date
28200	Layer			0.33	Ploughsoil. Grey brown, silty clay		
28201	Layer			0.13	Subsoil. Dark grey brown, silty clay		
28202	Layer				Natural. Brown orange, silty clay		
Trench 283							
General description					Orientation		SE-NW
Trench devoid of archaeology. Consists of ploughsoil and subsoil overlying natural geology of sandy clay.					Length (m)		30
					Width (m)		2.1
					Avg. depth (m)		0.31
Context No.	Type	Fill Of	Width (m)	Depth (m)	Description	Finds	Date
28300	Layer			0.25	Ploughsoil. Dark brown greyish, clayey silt		
28301	Layer			0.06	Subsoil. Orangish brown sandy clay with occasional sub-angular stones.		
28302	Layer				Natural. Brownish orange sandy clay with patches of gravel.		
Trench 284							
General description					Orientation		NW-SE
Trench revealed one ditch. Consists of ploughsoil and subsoil overlying natural geology of silty clay.					Length (m)		30
					Width (m)		2
					Avg. depth (m)		0.46
Context No.	Type	Fill Of	Width (m)	Depth (m)	Description	Finds	Date
28400	Layer			0.32	Ploughsoil. Grey brown, silty clay		

28401	Layer			0.14	Subsoil. Dark grey brown, silty clay, firm		
28402	Layer				Natural. Brown orange, silty clay		
28403	Cut		0.65	0.1	Ditch		
28404	Fill	28403	0.65	0.1	Primary Fill. Dark brown grey, silty sand.	Pot	AD 43-410

Trench 285

General description					Orientation	NE-SW		
Trench contained one curvilinear ditch. Consists of ploughsoil and subsoil overlaying natural geology of silty clay.					Length (m)	30		
					Width (m)	2		
					Avg. depth (m)	0.41		
Context No.	Type	Fill Of	Width (m)	Depth (m)	Description	Finds	Date	
28500	Layer			0.31	Ploughsoil. Greyish brown, silty clay, friable			
28501	Layer			0.1	Subsoil. Dark grey brown, silty clay			
28502	Layer				Natural. Brown orange, silty clay, firm			
28503	Cut		0.7	0.16	Ring Ditch			
28504	Fill	28503	0.7	0.16	Secondary Fill. Light brownish grey, sandy silt			

Trench 286

General description					Orientation	E-W		
Trench devoid of archaeology. Consists of ploughsoil and subsoil overlying natural geology of sandy clay.					Length (m)	30		
					Width (m)	2.1		
					Avg. depth (m)	0.36		
Context No.	Type	Fill Of	Width (m)	Depth (m)	Description	Finds	Date	
28600	Layer			0.3	Ploughsoil. Dark brown greyish, clayey silt			
28601	Layer			0.06	Subsoil. Light brown orangish, clayey silt			
28602	Layer				Natural. Orange brownish, sandy clay with gravelly patches			

Trench 287

General description					Orientation	NE-SW		
Trench devoid of archaeology. Consists of ploughsoil and subsoil overlying natural geology of sandy clay.					Length (m)	30		
					Width (m)	2.1		

						Avg. depth (m)	0.45
Context No.	Type	Fill Of	Width (m)	Depth (m)	Description	Finds	Date
28700	Layer			0.38	Ploughsoil. Dark brown greyish, clayey silt		
28701	Layer			0.07	Subsoil. Yellowish orange and mid orangish yellow silty sand with gravel		
28702	Layer		2.1	0.02	Natural. Mottled mid orangish yellow silty sand with gravel		

Trench 288

General description						Orientation	E-W
Trench devoid of archaeology. Consists of ploughsoil and subsoil overlying natural geology of sandy clay.						Length (m)	30
						Width (m)	2.1
						Avg. depth (m)	0.44

Context No.	Type	Fill Of	Width (m)	Depth (m)	Description	Finds	Date
28800	Layer			0.37	Ploughsoil. Dark brown greyish, clayey silt		
28801	Layer			0.07	Subsoil. Orangish brown sandy clay with occasional sub-angular stones.		
28802	Layer				Natural. Brownish orange sandy clay with gravel.		

Trench 289

General description						Orientation	NE-SW
Trench revealed one ditch. Consists of ploughsoil and subsoil overlying natural geology of sandy clay.						Length (m)	30
						Width (m)	2.1
						Avg. depth (m)	0.41

Context No.	Type	Fill Of	Width (m)	Depth (m)	Description	Finds	Date
28900	Layer			0.34	Ploughsoil. Dark brown greyish, clayey silt.		
28901	Layer			0.07	Subsoil. Orangish brown sandy clay with occasional sub-angular stones.		
28902	Layer				Natural. Brownish orange sandy clay with gravel		

28903	Cut		1	0.2	Ditch		
28904	Fill	28903			Secondary Fill		
28905	Cut				Natural Feature. Light reddish grey, compact, sandy clay fill		
28906	Cut				Natural Feature. Light yellowish brown, silty clay, compact fill		

Trench 290

General description					Orientation		NNE-SSE
Trench revealed two ditches and one pit. Consists of ploughsoil and subsoil overlying natural geology of sandy clay.					Length (m)		30
					Width (m)		2.1
					Avg. depth (m)		0.42

Context No.	Type	Fill Of	Width (m)	Depth (m)	Description	Finds	Date
29000	Layer			0.35	Ploughsoil. Dark brownish grey, clayey silt		
29001	Layer			0.07	Subsoil. Orangish brown sandy clay with occasional sub-angular stones.		
29002	Layer				Natural. Brownish orange sandy clay with occasional sub-angular stones.		
29003	Cut		0.6	0.26	Pit		
29004	Fill	29003	0.6	0.26	Secondary Fill. Orangey grey silty clay. Small amount of charcoal present		
29005	Cut		1.91	0.52	Ditch		
29006	Fill	29005	1.91	0.52	Secondary Fill. Dark orangey grey silty clay.	Pot	1270-1350
29007	Cut		0.4	0.12	Ditch		
29008	Fill	29007	0.4	0.12	Secondary Fill. Greyish orange, sandy silt, soft.		

Trench 291

General description					Orientation		NE-SW
Trench revealed two ditches. One natural feature. Consists of ploughsoil and subsoil overlying natural geology of sandy clay.					Length (m)		30
					Width (m)		2.1
					Avg. depth (m)		0.37

Context No.	Type	Fill Of	Width (m)	Depth (m)	Description	Finds	Date
-------------	------	---------	-----------	-----------	-------------	-------	------

29100	Layer			0.32	Ploughsoil. Dark brown greyish, clayey silt		
29101	Layer			0.05	Subsoil. Orangish brown sandy clay with occasional sub-angular stones.		
29102	Layer				Natural. Brownish orange sandy clay with occasional sub-angular stones.		
29103	Cut		1.13	0.34	Ditch		
29104	Fill	29103	1.13	0.34	Primary Fill. Soft greyish orange, sandy silt		
29105	Cut		1.08	0.14	Ditch		
29106	Fill	29105	0.56	0.04	Primary Fill. Light orangeish brown, soft sandy clay, occasional small stones	Pot, AB	C 1100-1350
29107	Fill	29105	1.08	0.13	Secondary Fill. Mid greyish orange, soft silty sand		

Trench 292

General description	Orientation	NE-SW
Trench revealed one ditch and two pits. One natural feature. Consists of ploughsoil and subsoil overlying natural geology of sandy clay.	Length (m)	30
	Width (m)	2.1
	Avg. depth (m)	0.45

Context No.	Type	Fill Of	Width (m)	Depth (m)	Description	Finds	Date
29200	Layer			0.38	Ploughsoil. Dark brown greyish, clayey silt		
29201	Layer			0.07	Subsoil. Orangish brown sandy clay with occasional sub-angular stones.		
29202	Layer				Natural. Brownish orange sandy clay with occasional sub-angular stones.		
29203	Cut		0.66	0.18	Ditch		
29204	Fill	29203	0.66	0.18	Secondary Fill. Light grey orangish, clayey sand		
29205	Cut		0.8	0.23	Pit		

29206	Fill	29205		0.23	Other Fill. Grey orangish, clayey sand.		
29207	Cut		1.68	0.22	Pit		
29208	Fill	29207		0.22	Other Fill. Grey orange clayey sand.		
29209	Cut			0.12	Natural Feature. Grey, sandy silt, soft. Possible pond or hollow.		

Trench 293

General description					Orientation		E-W
Trench devoid of archaeology. Consists of ploughsoil and subsoil overlying natural geology of silty clay and gravel.					Length (m)		50
					Width (m)		2
					Avg. depth (m)		0.4
Context No.	Type	Fill Of	Width (m)	Depth (m)	Description	Finds	Date
29300	Layer			0.28	Ploughsoil. Brownish grey silty clay.		
29301	Layer			0.12	Subsoil. Greyish brown silty clay.		
29302	Layer				Natural. Light yellowish brown silty clay and gravel.		

Trench 294

General description					Orientation		E-W
Trench revealed one ditch and one pit. Trench consists of ploughsoil and sub soil overlying natural geology of silty clay and gravel.					Length (m)		30
					Width (m)		2
					Avg. depth (m)		0.49
Context No.	Type	Fill Of	Width (m)	Depth (m)	Description	Finds	Date
29400	Layer			0.36	Ploughsoil. Brown grey silty clay.	Flint	
29401	Layer			0.13	Subsoil. Grey brown silty clay.	Pot	50 BC-AD70
29402	Layer				Natural. Yellow brown silty clay with gravel.		
29403	Cut		0.47	0.18	Ditch		
29404	Fill	29403	0.47	0.18	Primary Fill. Light greyish brown silty clay.		
29405	Cut		4.4	0.54	Pit		
29406	Fill	29405	4.4	0.42	Deliberate Backfill. Greyish brown clayish sand.	Pot, AB	? C5-7

29407	Fill	29405	2.5	0.12	Secondary Fill. Blackish brown sandy clay.	Pot, AB, CBM, <S9>	MC Preh/Sax pot, CBM ?? C15-C18
-------	------	-------	-----	------	--	--------------------	---------------------------------

Trench 295

General description	Orientation	E-W
Trench revealed two ditches. Consists of ploughsoil and subsoil overlying natural geology of silty clay and gravel.	Length (m)	30
	Width (m)	2
	Avg. depth (m)	0.52

Context No.	Type	Fill Of	Width (m)	Depth (m)	Description	Finds	Date
29500	Layer				Natural. Stony reddish brown silty sand		
29501	Layer			0.15	Subsoil. Yellowish brown sandy silt		
29502	Layer			0.37	Ploughsoil. Dark reddish brown silt		
29503	Cut				Natural Feature		
29504	Cut		2.26	0.3	Ditch		
29505	Fill	29504		0.3	Secondary Fill. Reddish brown sandy silt.		
29506	Cut				Ditch		
29507	Fill	29506		0.08	Secondary Fill. Light greyish brown sandy clay.		
29508	Fill	29506		0.2	Secondary Fill. Yellowish brown sandy silt.		

Trench 296

General description	Orientation	N-S
Trench revealed one ditch. Consists of ploughsoil overlying a sandy clay gravel natural.	Length (m)	20
	Width (m)	2
	Avg. depth (m)	0.37

Context No.	Type	Fill Of	Width (m)	Depth (m)	Description	Finds	Date
29600	Layer			0.26	Ploughsoil. Dark grey clayey silt.		
29601	Layer			0.11	Subsoil. Greyish brown silty clay.		
29602	Cut		1.8	0.46	Ditch		
29603	Fill	29602	0.93	0.33	Primary Fill. Greyish blue sandy clay.		
29604	Fill	29602	1.8	0.21	Secondary Fill. Brownish grey clayey silt.		

29605	Layer				Natural. Yellowish brown silty clay and gravel.		
Trench 297							
General description					Orientation		E-W
Trench revealed one ditch. Consists of ploughsoil and subsoil overlying natural geology of silty clay and gravel.					Length (m)		30
					Width (m)		2
					Avg. depth (m)		0.44
Context No.	Type	Fill Of	Width (m)	Depth (m)	Description	Finds	Date
29700	Layer			0.3	Topsoil. Greyish brown silt.		
29701	Layer			0.14	Subsoil. Orangish grey silty clay with gravels.		
29702	Layer				Natural. Light reddish grey silt clay with gravels.		
29703	Cut		0.71	0.17	Ditch		
29704	Fill	29703	0.71	0.17	Primary Fill. Reddish grey silty clay.		
Trench 298							
General description					Orientation		N-S
Trench revealed four ditches and three pits. Consists of ploughsoil and subsoil overlying natural geology of silty clay and gravel.					Length (m)		20
					Width (m)		2
					Avg. depth (m)		0.5
Context No.	Type	Fill Of	Width (m)	Depth (m)	Description	Finds	Date
29800	Layer			0.38	Ploughsoil. Dark grey brown sandy silt.		
29801	Layer			0.12	Subsoil. Yellow orange clayey silt.		
29802	Layer				Natural. Light yellow clayey silt with patches of blueish grey clayey silt as well as patches of dense gravel.		
29803	Cut		1.45	0.37	Ditch		
29804	Fill	29803	1.45	0.37	Primary Fill. Dark grey brown clayey silt.	Pot, BF	AD 900-1150
29805	Fill	29803	0.31	0.17	Secondary Fill. Light brownish grey clayey silt.		
29806	Cut		0.66	0.16	Ditch		

29807	Fill	29806	0.66	0.16	Primary Fill. Grey brown clayey silt.		
29808	Cut		1	0.4	Ditch		
29809	Fill	29808	1	0.4	Primary Fill. Brown grey clayey silt.	Pot	50BC-AD70
29810	Cut		1.11	0.12	Pit		
29811	Fill	29810	1.11	0.12	Primary Fill. Brownish grey clay silt.	Pot	LBA-MIA
29812	Cut		1.45	0.37	Ditch		
29813	Fill	29812	1.45	0.37	Primary Fill. Dark grey brown clayey silt.		
29814	Cut		0.8	0.08	Pit		
29815	Fill	29814	0.8	0.08	Primary Fill. Brown clayey silt.		
29816	Unexcavated feature		0.8		Unexcavated feature Possible pit, brown grey clayey silt.		

Trench 299

General description					Orientation		N-S
Trench devoid of archaeology. Trench consists of ploughsoil and subsoil overlying natural geology of sandy clay and gravels.					Length (m)		20
					Width (m)		2
					Avg. depth (m)		0.51
Context No.	Type	Fill Of	Width (m)	Depth (m)	Description	Finds	Date
29900	Layer			0.39	Ploughsoil. Dark greyish brown silt.		
29901	Layer			0.12	Subsoil. Reddish brown sandy clay.		
29902	Layer				Natural. Reddish brown sandy clay with gravel.		
29903	Cut				Natural Feature		

Trench 300

General description					Orientation		W-E
Trench devoid of archaeology. Consists of ploughsoil and subsoil overlying natural geology of silty clay and gravel.					Length (m)		30
					Width (m)		2
					Avg. depth (m)		0.38
Context No.	Type	Fill Of	Width (m)	Depth (m)	Description	Finds	Date
30000	Layer			0.26	Ploughsoil. Mid brownish grey silty clay.		

30001	Layer			0.12	Subsoil. Mid greyish brown silty clay.		
30002	Layer				Natural. Mid reddish brown silty clay and light grey gravel.		

Trench 301							
General description					Orientation		N-S
Trench devoid of archaeology. Consists of ploughsoil and subsoil overlying natural geology of silty clay and gravel.					Length (m)		30
					Width (m)		2
					Avg. depth (m)		0.4
Context No.	Type	Fill Of	Width (m)	Depth (m)	Description	Finds	Date
30100	Layer			0.28	Ploughsoil. Brownish grey silty clay.		
30101	Layer			0.12	Subsoil. Greyish brown silty clay.		
30102	Layer				Natural. Light yellowish brown silty clay and gravel.		

Trench 302							
General description					Orientation		E-W
Trench revealed one pit. Consists of ploughsoil and subsoil overlying natural geology of sandy clay and gravel.					Length (m)		30
					Width (m)		2
					Avg. depth (m)		0.5
Context No.	Type	Fill Of	Width (m)	Depth (m)	Description	Finds	Date
30200	Layer			0.34	Ploughsoil. Dark greyish brown clayey silt.		
30201	Layer			0.16	Subsoil. Reddish brown sandy clay.		
30202	Layer				Natural. Reddish brown sandy clay and grey gravel.		
30203	Cut		0.3	0.12	Pit		
30204	Fill	30203	0.3	0.12	Secondary Fill. Grey sandy clay.		
30205	Cut				Natural Feature		

Trench 303							
General description					Orientation		N-S
Trench devoid of archaeology. Trench consists of ploughsoil and subsoil overlying natural geology of sandy clay.					Length (m)		30
					Width (m)		2

						Avg. depth (m)	0.44
Context No.	Type	Fill Of	Width (m)	Depth (m)	Description	Finds	Date
30300	Layer			0.32	Ploughsoil. Dark greyish brown clayey silt.		
30301	Layer			0.12	Subsoil. Reddish brown sandy clay.		
30302	Layer			0.39	Natural. Brown sandy clay.		
30303	Cut				Natural Feature		

Trench 304

General description	Orientation	W-E
Trench revealed one post-hole. Consists of ploughsoil and subsoil overlying natural geology of silty clay and gravel.	Length (m)	30
	Width (m)	2
	Avg. depth (m)	0.39

Context No.	Type	Fill Of	Width (m)	Depth (m)	Description	Finds	Date
30400	Layer			0.28	Ploughsoil. Brownish grey silty clay.		
30401	Layer			0.11	Subsoil. Light greyish brown silty clay.		
30402	Layer				Natural. Reddish brown silty clay and gravel.		
30403	Cut		0.5	0.08	Posthole		
30404	Fill	30403	0.5	0.08	Secondary Fill. Dark brown sandy silt with charcoal flecks.	<S12>	

Trench 305

General description	Orientation	N-S
Trench devoid of archaeology. Trench consists of ploughsoil and subsoil overlying natural geology of sandy clay.	Length (m)	30
	Width (m)	2
	Avg. depth (m)	0.48

Context No.	Type	Fill Of	Width (m)	Depth (m)	Description	Finds	Date
30500	Layer			0.39	Ploughsoil. Dark greyish brown clayey silt.		
30501	Layer			0.09	Subsoil. Greyish brown sandy clay.		
30502	Layer				Natural. Yellowish brown sandy clay and gravel.		
30503	Cut		0.58	0.06	Natural Feature		

Trench 306							
General description					Orientation		N-S
Trench devoid of archaeology. Trench consists of ploughsoil and subsoil overlying sandy clay and gravel natural.					Length (m)		30
					Width (m)		2
					Avg. depth (m)		0.52
Context No.	Type	Fill Of	Width (m)	Depth (m)	Description	Finds	Date
30600	Layer			0.29	Ploughsoil. Greyish brown clayey silt.		
30601	Layer			0.23	Subsoil. Reddish brown sandy clay.		
30602	Layer				Natural. Orangish brown sandy clay and gravel.		
30603	Cut				Natural Feature		
Trench 307							
General description					Orientation		E-W
Trench revealed one posthole and one ditch. Consists of ploughsoil and subsoil overlying a sandy clay natural with gravel inclusions.					Length (m)		30
					Width (m)		2
					Avg. depth (m)		0.39
Context No.	Type	Fill Of	Width (m)	Depth (m)	Description	Finds	Date
30700	Layer			0.29	Ploughsoil. Dark grey firm clayey soil.		
30701	Layer			0.1	Subsoil. Light greyish brown silty.		
30702	Cut		0.96	0.48	Ditch		
30703	Fill	30702	0.96	0.48	Primary Fill. Greyish brown sandy silt.		
30704	Cut		0.27	0.19	Posthole		
30705	Fill	30704	0.27	0.19	Primary Fill. Light greyish brown sandy silt.		
30706	Layer				Natural. Yellowish brown silty clay and gravel.		
Trench 308							
General description					Orientation		W-E
Trench devoid of archaeology. Consists of ploughsoil and subsoil overlying natural geology of silty clay.					Length (m)		30
					Width (m)		2
					Avg. depth (m)		0.42

Context No.	Type	Fill Of	Width (m)	Depth (m)	Description	Finds	Date
30800	Layer			0.38	Ploughsoil. Dark grey clayey silt.		
30801	Layer			0.04	Subsoil. Light orangey grey silty clay.		
30802	Layer				Natural. Orangey grey silty clay.		

Trench 309

General description	Orientation	N-S
Trench devoid of archaeology. Consists of ploughsoil and subsoil overlying natural geology of silty clay and gravel.	Length (m)	30
	Width (m)	2
	Avg. depth (m)	0.4

Context No.	Type	Fill Of	Width (m)	Depth (m)	Description	Finds	Date
30900	Layer			0.3	Ploughsoil. Brownish grey silty clay.		
30901	Layer			0.1	Subsoil. Greyish brown silty clay.		
30902	Layer				Natural. Light yellowish brown silty clay and gravel.		

Trench 310

General description	Orientation	E-W
Trench revealed three ditches. Consists of ploughsoil and subsoil overlying natural geology of silty clay and gravel.	Length (m)	30
	Width (m)	2
	Avg. depth (m)	0.47

Context No.	Type	Fill Of	Width (m)	Depth (m)	Description	Finds	Date
31000	Layer			0.38	Ploughsoil. Greyish brown, silty soil.		
31001	Layer			0.09	Subsoil. Light greyish brown, silty clay.		
31002	Layer				Natural. Greyish orange, sandy clay.		
31003	Cut		0.85	0.36	Ditch		
31004	Fill	31003	0.85	0.36	Primary Fill. Reddish grey, silty clay.	Flint	Early Preh
31005	Cut		0.83	0.12	Ditch		
31006	Fill	31005	0.83	0.12	Primary Fill. Light brownish grey, silty clay.		
31007	Cut		0.33	0.11	Ditch		

31008	Fill	31007	0.33	0.11	Primary Fill. Light brownish grey, silty clay.		
Trench 311							
General description					Orientation		N-S
Trench devoid of archaeology. Consists of ploughsoil and subsoil overlying natural geology of silty clay and gravel.					Length (m)		30
					Width (m)		2
					Avg. depth (m)		0.4
Context No.	Type	Fill Of	Width (m)	Depth (m)	Description	Finds	Date
31100	Layer			0.29	Ploughsoil. Brownish grey silty clay.		
31101	Layer			0.11	Subsoil. Light greyish brown silty clay.		
31102	Layer				Natural. Reddish brown silty clay and gravel.		
Trench 312							
General description					Orientation		E-W
Trench revealed three ditches, three postholes and a pit. Consists of ploughsoil and subsoil overlying natural geology.					Length (m)		30
					Width (m)		2
					Avg. depth (m)		0.42
Context No.	Type	Fill Of	Width (m)	Depth (m)	Description	Finds	Date
31200	Layer			0.31	Ploughsoil. Greyish brown, silty clay.		
31201	Layer			0.11	Subsoil. Light greyish brown silty clay.		
31202	Cut		1.4	0.16	Ditch		
31203	Fill	31202	1.4	0.16	Secondary Fill. Light greyish brown, silty clay,	CBM	C19
31204	Cut		0.93	0.14	Ditch		
31205	Fill	31204	0.93	0.14	Primary Fill. Light brownish grey, silty clay.		
31206	Cut		0.25	0.2	Posthole		
31207	Fill	31206	0.25	0.2	Primary Fill. Greyish brown, silty clay.	Clay Pipe, CBM	L17-E18C
31208	Cut		0.3	0.06	Posthole		
31209	Fill	31208	0.3	0.06	Primary Fill. Brownish grey, silty clay.	CBM	PMed
31210	Cut		1.8	0.16	Ditch		

31211	Fill	31210	1.8	0.16	Primary Fill. Light greyish brown, silty clay.		
31212	Unexcavated feature		0.34		Pit. Reddish brown, silty clay.		
31213	Unexcavated feature		0.2		Posthole. Light greyish brown, silty clay.		
31214	Layer				Natural. Brownish orange, silty clay gravel.		

Trench 313

General description					Orientation	NE-SW	
Trench revealed one ditch. Consists of ploughsoil and subsoil overlying natural geology of silty clay.					Length (m)	30	
					Width (m)	2	
					Avg. depth (m)	0.42	
Context No.	Type	Fill Of	Width (m)	Depth (m)	Description	Finds	Date
31300	Layer			0.28	Ploughsoil. Brownish grey silty clay.		
31301	Layer			0.14	Subsoil. Light brownish grey silty clay.		
31302	Layer				Natural. Light yellowish brown silty clay.		
31303	Cut				Natural Feature. Probably residual subsoil.		
31304	Unexcavated feature				Ditch. Light greyish brown silty clay.		

Trench 314

General description					Orientation	E-W	
Trench revealed one ditch. Consists of ploughsoil overlying a clayey sand natural.					Length (m)	30	
					Width (m)	2	
					Avg. depth (m)	0.4	
Context No.	Type	Fill Of	Width (m)	Depth (m)	Description	Finds	Date
31400	Layer			0.29	Ploughsoil. Dark grey clayey silt.		
31401	Layer			0.11	Subsoil. Greyish brown silty clay.		
31402	Cut		2.57	0.58	Ditch		
31403	Fill	31402	2.57	0.58	Primary Fill. Dark greyish brown firm clayey silt.	CBM	MC15-C18
31404	Layer				Natural. Reddish brown		

					silty clay and gravel.		
Trench 315							
General description					Orientation		N-S
Trench devoid of archaeology. Consists of ploughsoil and subsoil overlying natural geology of silty clay.					Length (m)		30
					Width (m)		2
					Avg. depth (m)		0.42
Context No.	Type	Fill Of	Width (m)	Depth (m)	Description	Finds	Date
31500	Layer			0.28	Ploughsoil. Mid brownish grey silty clay.	Flint	
31501	Layer			0.14	Subsoil. Light greyish brown silty clay.		
31502	Layer				Natural. Light yellowish brown silty clay.		
Trench 316							
General description					Orientation		E-W
Trench revealed two ditches. Trench consists of ploughsoil overlying a natural geology of sandy silt with gravel.					Length (m)		30
					Width (m)		2
					Avg. depth (m)		0.35
Context No.	Type	Fill Of	Width (m)	Depth (m)	Description	Finds	Date
31600	Layer			0.3	Ploughsoil. Brown grey silty clay.		
31601	Layer			0.05	Subsoil. Light greyish brown silty clay.		
31602	Layer				Natural. Orange brown sandy silt with occasional gravel.		
31603	Cut		0.8	0.5	Ditch		
31604	Fill	31603	0.8		Deliberate Backfill. Light greyish yellow clayey silt.	Pot, Flint x 5, BF, <S11>	Preh/Sax?
31605	Cut		0.8	0.58	Ditch		
31606	Fill	31605	0.8	0.58	Deliberate Backfill. Light blueish yellow clayey silt.	Flint	Preh
Trench 317							
General description					Orientation		N-S
Trench revealed one pit. Consists of ploughsoil and subsoil overlying natural geology of silty clay with gravels.					Length (m)		30
					Width (m)		2
					Avg. depth (m)		0.37

Context No.	Type	Fill Of	Width (m)	Depth (m)	Description	Finds	Date
31700	Layer			0.3	Ploughsoil. Greyish brown silt.		
31701	Layer			0.07	Subsoil. Reddish brown sandy silt.		
31702	Layer				Natural. Reddish brown silt clay with gravels.		
31703	Cut		0.66	0.14	Pit		
31704	Fill	31703	0.66	0.14	Primary Fill. Blueish grey silty clay.	<S10>	

Trench 318

General description	Orientation	E-W
Trench revealed two ditches. Consists of ploughsoil and subsoil overlying natural geology of clay and gravel patches.	Length (m)	30
	Width (m)	2
	Avg. depth (m)	0.45

Context No.	Type	Fill Of	Width (m)	Depth (m)	Description	Finds	Date
31800	Layer		2	0.3	Ploughsoil. Dark greyish brown, silty clay.		
31801	Layer		2	0.15	Subsoil. Yellowish brown, silty clay.		
31802	Layer		2		Natural. Light yellowish brown, silty clay with patches of gravel.		
31803	Cut		0.9	0.23	Ditch		
31804	Fill	31803	0.9	0.23	Primary Fill. Reddish brown, silty clay.		
31805	Cut		0.75	0.18	Ditch		
31806	Fill	31805	0.75	0.18	Primary Fill. Light greyish brown, silty clay.		
31807	Cut		2		Natural Feature. Natural geology		

Trench 319

General description	Orientation	NE-SW
Trench devoid of archaeology. Consists of ploughsoil, CBM layer and subsoil overlying natural geology of silty clay and gravel.	Length (m)	30
	Width (m)	2
	Avg. depth (m)	0.46

Context No.	Type	Fill Of	Width (m)	Depth (m)	Description	Finds	Date
-------------	------	---------	-----------	-----------	-------------	-------	------

31900	Layer			0.36	Ploughsoil. Brownish grey silty clay.		
31901	Layer			0.05	Other Layer.	CBM	Post-med
31902	Layer			0.08	Subsoil. Brownish grey silty clay.		
31903	Layer				Natural. Mid yellowish brown silty clay and gravel.		

Trench 320

General description	Orientation	NE-SW
Trench devoid of archaeology. Consists of ploughsoil and subsoil overlying natural geology of sandy clay.	Length (m)	30
	Width (m)	2
	Avg. depth (m)	0.3

Context No.	Type	Fill Of	Width (m)	Depth (m)	Description	Finds	Date
32000	Layer			0.18	Ploughsoil. Greyish brown silt.		
32001	Layer			0.11	Subsoil. Light yellowish grey sandy silt.		
32002	Layer				Natural. Light yellowish brown sandy clay.		
32003	Cut		0.26	0.03	Natural Feature. Grey silt.		

Trench 321

General description	Orientation	N-S
Trench revealed one ditch. Consists of ploughsoil and subsoil overlying a clayey sand natural.	Length (m)	30
	Width (m)	2
	Avg. depth (m)	0.39

Context No.	Type	Fill Of	Width (m)	Depth (m)	Description	Finds	Date
32100	Layer			0.3	Ploughsoil. Dark grey clayey silt.		
32101	Layer			0.09	Subsoil. Greyish brown silty clay.		
32102	Unexcavated feature		1.8		Ditch. NW-SE aligned. Dark brownish grey clayey silt.		
32103	Layer				Natural. Yellowish brown clayey sand.		

Trench 322

General description	Orientation	E-W
	Length (m)	30

Trench devoid of archaeology. Consists of ploughsoil and subsoil overlying natural geology of silty clay.						Width (m)	2
						Avg. depth (m)	0.45
Context No.	Type	Fill Of	Width (m)	Depth (m)	Description	Finds	Date
32200	Layer			0.29	Ploughsoil. Brownish grey silty clay.		
32201	Layer			0.16	Subsoil. Light greyish brown silty clay.		
32202	Layer				Natural. Yellowish brown silty clay.		
Trench 323							
General description						Orientation	W-E
Trench revealed two ditches. Consists of ploughsoil and subsoil overlying a natural geology of silty clay with gravel.						Length (m)	30
						Width (m)	2
						Avg. depth (m)	0.45
Context No.	Type	Fill Of	Width (m)	Depth (m)	Description	Finds	Date
32300	Layer			0.3	Ploughsoil. Brownish grey silty clay.		
32301	Layer			0.15	Subsoil. Greyish brown silty clay.		
32302	Layer				Natural. Orange brown silty clay with occasional gravel.		
32303	Cut		0.62	0.4	Ditch		
32304	Fill	32303	0.62	0.4	Blueish brown silty clay.		
32305	Unexcavated feature		1.1		Ditch. NW-SE aligned, excavated in parallel trench 316.		
Trench 324							
General description						Orientation	W-E
Trench revealed one ditch. Consists of ploughsoil and subsoil overlying sandy clay and gravel natural.						Length (m)	30
						Width (m)	2
						Avg. depth (m)	0.44
Context No.	Type	Fill Of	Width (m)	Depth (m)	Description	Finds	Date
32400	Layer			0.3	Ploughsoil. Brownish grey silty clay.		
32401	Layer			0.14	Subsoil. Greyish brown silty clay.		
32402	Layer				Natural. Reddish brown		

					silty clay and gravel.		
32403	Cut		0.55	0.1	Natural Feature		
32404	Cut		0.55	0.1	Ditch		
32405	Fill	32404	0.55	0.1	Primary Fill. Reddish brown sandy clay.		
Trench 325							
General description					Orientation	NE-SW	
Trench devoid of archaeology. Consists of ploughsoil and subsoil overlying natural geology of silty clay.					Length (m)	30	
					Width (m)	2	
					Avg. depth (m)	0.46	
Context No.	Type	Fill Of	Width (m)	Depth (m)	Description	Finds	Date
32500	Layer			0.3	Ploughsoil. Mid brownish grey silty clay.		
32501	Layer			0.16	Subsoil. Light greyish brown silty clay.		
32502	Layer				Natural. Mid yellowish brown silty clay.		

Trench 326							
General description					Orientation	ENE-WSW	
Trench devoid of archaeology. Trench consists of ploughsoil and subsoil overlying sandy clay natural.					Length (m)	30	
					Width (m)	2	
					Avg. depth (m)	0.43	
Context No.	Type	Fill Of	Width (m)	Depth (m)	Description	Finds	Date
32600	Layer			0.28	Ploughsoil. Dark greyish brown clayey silt.		
32601	Layer			0.15	Subsoil. Reddish brown sandy clay.		
32602	Layer				Natural. Reddish brown sandy clay.		
32603	Cut		0.38	0.1	Natural Feature. Greyish silty clay fill.		

Trench 327							
General description					Orientation	S-N	
Trench devoid of archaeology. Consists of plough soil and subsoil overlying the natural geology of silty clay.					Length (m)	30	
					Width (m)	2	
					Avg. depth (m)	0.47	
Context No.	Type	Fill Of	Width (m)	Depth (m)	Description	Finds	Date

32700	Layer			0.33	Ploughsoil. Dark greyish brown clayey silt.		
32701	Layer			0.14	Subsoil. Yellowish brown sandy clay.		
32702	Layer				Natural. Yellowish brown sandy clay.		

Trench 328

General description	Orientation	W-E
Trench revealed a single ditch. Trench consists of ploughsoil overlying a sandy clay and gravel natural.	Length (m)	30
	Width (m)	2
	Avg. depth (m)	0.38

Context No.	Type	Fill Of	Width (m)	Depth (m)	Description	Finds	Date
32800	Layer			0.34	Ploughsoil. Brownish grey silty clay.		
32801	Layer			0.04	Subsoil. Light greyish brown silty clay.		
32802	Cut	32802	0.77	0.13	Ditch		
32803	Fill	32802	0.77	0.13	Primary Fill. Light brownish-grey, sandy silt.		
32804	Cut		1.58	0.11	Natural Feature. Natural depression. Fill is a loose, light yellowish-grey clayey silt.		
32805	Layer				Natural. Reddish brown silty clay and gravel.		

Trench 329

General description	Orientation	E-W
Trench is devoid of archaeology. Trench itself consists of ploughsoil overlying a natural geology of silty clay.	Length (m)	30
	Width (m)	2
	Avg. depth (m)	0.51

Context No.	Type	Fill Of	Width (m)	Depth (m)	Description	Finds	Date
32900	Layer			0.36	Ploughsoil. Brown grey silty clay.		
32901	Layer			0.15	Subsoil. Reddish brown sandy clay.		
32902	Layer				Natural. Orange brown silty clay.		

Trench 330

General description						Orientation	E-W
Trench devoid of archaeology. Consists of ploughsoil and subsoil overlying sandy clay and gravel natural.						Length (m)	30
						Width (m)	
						Avg. depth (m)	0.48
Context No.	Type	Fill Of	Width (m)	Depth (m)	Description	Finds	Date
33000	Layer			0.38	Ploughsoil. Dark greyish brown clayey silt		
33001	Layer			0.1	Subsoil. Dark yellowish brown sandy clay		
33002	Layer				Natural. Reddish brown sandy clay and gravel		
33003	Void						
Trench 331							
General description						Orientation	N-S
Trench revealed one ditch. Consists of ploughsoil and subsoil overlying natural geology of silty clay and gravel.						Length (m)	30
						Width (m)	2
						Avg. depth (m)	0.43
Context No.	Type	Fill Of	Width (m)	Depth (m)	Description	Finds	Date
33100	Layer			0.3	Ploughsoil. Dark brown grey Sandy silt		
33101	Layer			0.17	Subsoil. Light brown yellow clayey silt		
33102	Layer				Natural. Light brown yellow clayey silt		
33103	Cut		0.78	0.27	Ditch		
33104	Fill	33103	0.78	0.27	Light grey brown clay silt		
Trench 332							
General description						Orientation	ENE-WSW
Trench revealed one ditch and a pond. Trench consists of ploughsoil and subsoil overlying sandy clay natural.						Length (m)	30
						Width (m)	2
						Avg. depth (m)	0.45
Context No.	Type	Fill Of	Width (m)	Depth (m)	Description	Finds	Date
33200	Layer			0.38	Ploughsoil. Dark grey firm clayey silt		
33201	Layer			0.07	Subsoil. Light greyish brown silty clay.		
33202	Cut		0.87	0.11	Ditch. N-S aligned		

33203	Fill	33202	0.87	0.11	Primary Fill. Brownish grey clayey sily		
33204	Cut		8		Pond		
33205	Fill	33204	0.5		Primary Fill. Brownish grey clayey silt.		
33206	Fill	33204	7.5		Secondary Fill. Greyish brown clayey silt.	Pot, Fe nail and bar, CBM	AD 1850- 1900
33207	Layer				Natural. Yellowish brown sandy clay		

Trench 333

General description	Orientation	N-S
---------------------	-------------	-----

Trench devoid of archaeology. Consists of ploughsoil and subsoil over natural geology.	Length (m)	30
	Width (m)	2
	Avg. depth (m)	0.36

Context No.	Type	Fill Of	Width (m)	Depth (m)	Description	Finds	Date
33300	Layer			0.28	Ploughsoil. Dark brown/grey sandy silt		
33301	Layer			0.08	Subsoil. Greyish brown silty clay		
33302	Layer				Natural. Orange brown silty clay and gravel.		

Trench 334

General description	Orientation	NW-SE
---------------------	-------------	-------

Trench revealed one ditch. Consists of ploughsoil and subsoil overlying sandy clay and gravel natural.	Length (m)	30
	Width (m)	2
	Avg. depth (m)	0.41

Context No.	Type	Fill Of	Width (m)	Depth (m)	Description	Finds	Date
33400	Layer			0.3	Ploughsoil. Greyish brown silt.		
33401	Layer			0.11	Subsoil. Reddish brown clayey silt.		
33402	Layer				Natural. Reddish brown silty clay with gravel inclusions.		
33403	Cut		0.78	0.09	Natural Feature. Greyish brown clayey silt.		
33404	Cut				Ditch		
33405	Fill				Primary Fill. Greyish brown silty clay		

Trench 335							
General description					Orientation		NW-SE
Trench revealed one pit. Trench consists of plough soil and subsoil overlying clayey sand natural.					Length (m)		30
					Width (m)		2
					Avg. depth (m)		0.45
Context No.	Type	Fill Of	Width (m)	Depth (m)	Description	Finds	Date
33500	Layer			0.34	Ploughsoil. Dark grey firm clayey silt		
33501	Layer			0.11	Subsoil. Reddish brown silty clay		
33502	Cut		4.53	0.69+	Pit, not bottomed.		
33503	Fill	33502	4.53	0.38	Primary Fill. Firm reddish brownish grey clayey silt	Pot, Flint	MBA-MIA
33504	Layer				Natural. Reddish brown sandy clay		
33505	Fill	33502	4.53	0.41	Secondary Fill. Soft mid greyish brown clayey silt	BF	
Trench 336							
General description					Orientation		E-W
Trench devoid of archaeology. Consists of ploughsoil and subsoil overlying natural geology of silty clay.					Length (m)		30
					Width (m)		2
					Avg. depth (m)		0.4
Context No.	Type	Fill Of	Width (m)	Depth (m)	Description	Finds	Date
33600	Layer			0.29	Ploughsoil. Brownish grey silty clay.		
33601	Layer			0.11	Subsoil. Light greyish brown silty clay.		
33602	Layer				Natural. Reddish brown silty clay.		
Trench 337							
General description					Orientation		N-S
Trench devoid of archaeology. Consists of ploughsoil and subsoil overlying natural geology of silty clay					Length (m)		30
					Width (m)		2
					Avg. depth (m)		0.41
Context No.	Type	Fill Of	Width (m)	Depth (m)	Description	Finds	Date
33700	Layer			0.28	Ploughsoil. Brownish grey silty clay		
33701	Layer			0.13	Subsoil. Light greyish brown silty clay		

33702	Layer				Natural. Reddish brown silty clay.		
Trench 338							
General description					Orientation	NE-SW	
Trench revealed one ditch. Trench itself consists of ploughsoil overlying a natural geology of silty clay.					Length (m)	30	
					Width (m)	2	
					Avg. depth (m)	0.33	
Context No.	Type	Fill Of	Width (m)	Depth (m)	Description	Finds	Date
33800	Layer			0.33	Ploughsoil. Brown grey silty clay.		
33801	Layer				Natural. Orange brown silty clay.		
33802	Cut		0.92	0.35	Ditch		
33803	Fill	33802	0.92	0.35	Primary Fill. Mottled blueish brown clayey silt.	BF	
Trench 339							
General description					Orientation	E-W	
Trench revealed two ditches. Consists of ploughsoil and subsoil overlying natural geology of silty clay.					Length (m)	30	
					Width (m)	2	
					Avg. depth (m)	0.49	
Context No.	Type	Fill Of	Width (m)	Depth (m)	Description	Finds	Date
33900	Layer			0.3	Ploughsoil. Dark grey clayey silt	Flint	
33901	Layer			0.19	Subsoil. Yellowish brown clayey silt		
33902	Layer				Natural. Dark reddish brown sandy clay		
33903	Cut		0.72	0.22	Ditch		
33904	Fill	33903	0.22	0.22	Primary Fill. Greyish brown silty clay.		
33905	Fill	33903	0.52	0.2	Secondary Fill. Light greyish blueish brown silty clay.		
33906	Cut		0.76	0.51	Ditch		
33907	Fill	33906	0.76	0.51	Deliberate Backfill. Mottled grey and orange	Pot, flint, CBM, <S13>	AD43-410
Trench 340							
General description					Orientation	N-S	
					Length (m)	30	

Trench devoid of archaeology. Consisted of ploughsoil and subsoil overlying the natural geology of clay						Width (m)	2
						Avg. depth (m)	0.44
Context No.	Type	Fill Of	Width (m)	Depth (m)	Description	Finds	Date
34000	Layer			0.33	Ploughsoil. Dark grey firm clayey sily		
34001	Layer			0.18	Subsoil. Reddish brown clayey silt		
34002	Layer				Natural. Reddish brown sandy clay with gravel inclusions		
Trench 341							
General description						Orientation	E-W
Trench devoid of archaeology. Consists of ploughsoil and subsoil overlying natural geology of sandy clay.						Length (m)	30
						Width (m)	2
						Avg. depth (m)	0.44
Context No.	Type	Fill Of	Width (m)	Depth (m)	Description	Finds	Date
34100	Layer			0.37	Ploughsoil. Dark grey clayey silt		
34101	Layer			0.07	Subsoil. Reddish brown silty clay.		
34102	Layer				Natural. Reddish brown silty clay and gravel.		
Trench 342							
General description						Orientation	E-W
Trench devoid of archaeology. Trench consists of ploughsoil and subsoil overlying a sandy clay natural						Length (m)	30
						Width (m)	2
						Avg. depth (m)	0.44
Context No.	Type	Fill Of	Width (m)	Depth (m)	Description	Finds	Date
34200	Layer			0.32	Ploughsoil. Dark greyish brown clayey silt		
34201	Layer			0.12	Subsoil. Dark reddish brown sandy clay		
34202	Layer				Natural. Reddish brown sandy clay		
34203	Cut		0.46	0.06	Natural Feature. Fill of orangey brown silty clay		
Trench 343							
General description						Orientation	NE-SW
Trench revealed one ditch and an elongated pit. Trench consists of ploughsoil and subsoil overlying a clayey sand natural.						Length (m)	30
						Width (m)	2

						Avg. depth (m)	0.39
Context No.	Type	Fill Of	Width (m)	Depth (m)	Description	Finds	Date
34300	Layer			0.29	Ploughsoil. Dark grey firm clayey silt		
34301	Layer			0.1	Subsoil. Reddish brown clayey sily	Flint core	
34302	Layer				Natural. Reddish brown clayey sand	Flint	
34303	Cut		0.99	0.15	Ditch. N-S aligned		
34304	Fill	34303	0.99	0.15	Primary Fill. Greyish brown soft sandy silt	Pot, AB	AD200-410
34305	Unexcavated feature		1.52		Pit. Dark brownish grey sandy silt.	CBM	PMed
34306	Cut		1.2	0.18	Natural Feature		
34307	Fill	34306	1.2	0.18	Primary Fill. Reddish brown sandy silt.	Flint	Preh?

Trench 344

General description	Orientation	SE-NW
Trench devoid of archaeology. Consists of ploughsoil and subsoil overlying natural geology of silty clay and gravel.	Length (m)	30
	Width (m)	2
	Avg. depth (m)	0.55

Context No.	Type	Fill Of	Width (m)	Depth (m)	Description	Finds	Date
34400	Layer			0.3	Ploughsoil. Dark brown grey Sandy silt		
34401	Layer			0.25	Subsoil. Orange yellow clayey silt		
34402	Layer				Natural. Light orange yellow clayey silt		
34403	Cut		2	0.11	Ditch ? Filled by firm, dark reddish brown silty clay		

Trench 345

General description	Orientation	N-S
Trench devoid of archaeology. Consists of ploughsoil and subsoil overlying natural geology of silty clay and gravel.	Length (m)	30
	Width (m)	2
	Avg. depth (m)	0.34

Context No.	Type	Fill Of	Width (m)	Depth (m)	Description	Finds	Date
34500	Layer			0.28	Ploughsoil. Brownish grey silty clay		

34501	Layer			0.06	Subsoil. Light greyish brown silty clay		
34502	Layer				Natural. Yellowish brown silty clay		
Trench 346							
General description					Orientation	E-W	
Trench revealed four ditches. Consists of ploughsoil and subsoil overlying sandy clay natural.					Length (m)	30	
					Width (m)	2	
					Avg. depth (m)	0.36	
Context No.	Type	Fill Of	Width (m)	Depth (m)	Description	Findings	Date
34600	Layer			0.31	Ploughsoil. Dark brownish grey clayish silt	Flint end scraper	
34601	Layer			0.05	Subsoil. Yellowish brown sandy clay		
34602	Layer				Natural. Yellowish brown sandy clay		
34603	Cut		0.94	0.53	Ditch		
34604	Fill	34603	0.94	0.53	Deliberate Backfill. Firm, mid brownish-grey, sandy clay		
34605	Cut		0.86	0.46	Ditch		
34606	Fill	34605	0.86	0.46	Deliberate Backfill. Grey and brown mottled sandy clay		
34607	Cut		0.92	0.62	Ditch		
34608	Fill	34607	0.92	0.28	Deliberate Backfill. Mottled orange grey silty clay.		
34609	Fill		1	0.34	Mottled orange grey silty clay.		
34610	Cut		1	0.13	Natural Feature		
34611	Cut		0.56	0.28	Ditch		
34612	Fill	34611	0.56	0.28	Secondary Fill. Brownish grey clayish sand		
34613	Fill	34611			Deliberate Backfill		
Trench 347							
General description					Orientation	E-W	
Trench revealed two ditches. Trench consists of ploughsoil and subsoil overlying a clayey sand natural.					Length (m)	30	
					Width (m)	2	
					Avg. depth (m)	0.39	

Context No.	Type	Fill Of	Width (m)	Depth (m)	Description	Finds	Date
34700	Layer			0.34	Ploughsoil. Dark grey ploughsoil		
34701	Layer			0.05	Subsoil. Greyish brown silty clay		
34702	Cut		0.86	0.52	Ditch		
34703	Fill	34702	0.78	0.19	Primary Fill. Blueish grey sandy silt.		
34704	Fill	34702	0.86	0.37	Secondary Fill. Reddish brown clayey silt.	Pot	AD C5-8
34705	Fill	34702	0.51	0.26	Brownish grey sandy silt.	Pot	AD43-410
34706	Layer				Natural. Reddish brown sandy clay.		
34707	Layer				Natural. Greyish blue silty clay		
34708	Unexcavated feature		0.68		Ditch. Grey brown silt. Cultivation ditch.		

Trench 348

General description	Orientation	NE-SW
Trench devoid of archaeology. Trench itself consists of ploughsoil overlying a natural geology of silty clay.	Length (m)	30
	Width (m)	2
	Avg. depth (m)	0.42

Context No.	Type	Fill Of	Width (m)	Depth (m)	Description	Finds	Date
34800	Layer			0.34	Ploughsoil. Grey brown silty clay.		
34801	Layer			0.32	Natural. Orange brown silty clay.		
34802	Cut		0.64		Natural Feature		
34803	Layer			0.08	Subsoil. Brown yellowish brown sandy clay		

Trench 349

General description	Orientation	ESE-WNW
Trench revealed two ditches. Trench itself consists of ploughsoil and subsoil overlying a natural geology of silty clay.	Length (m)	30
	Width (m)	2
	Avg. depth (m)	0.44

Context No.	Type	Fill Of	Width (m)	Depth (m)	Description	Finds	Date
34900	Layer			0.27	Ploughsoil. Brown grey silty clay.		
34901	Layer				Natural. Yellow brown sandy silt with bands of		

					reddish brown clay		
34902	Unexcavated feature		0.3	0.14	Ditch ? or natural clay band?		
34903	Cut		0.69	0.08	Natural Feature		
34904	Layer			0.17	Subsoil. Yellowish brown sandy clay		
34905	Unexcavated feature		1		Ditch? Or natural clay band?		
Trench 350							
General description						Orientation	NE-SW
Trench devoid of archaeology. Trench consists of ploughsoil and subsoil over sandy clay natural.						Length (m)	30
						Width (m)	2
						Avg. depth (m)	0.3
Context No.	Type	Fill Of	Width (m)	Depth (m)	Description	Finds	Date
35000	Layer			0.24	Ploughsoil. Dark greyish brown clayey silt		
35001	Layer			0.06	Subsoil. Dark yellowish brown sandy clay		
35002	Layer				Natural. Yellowish brown sandy clay		
35003	Cut				Natural Feature		

B.1 Prehistoric Pottery

By Alex Davies

Introduction

- B.1.1 This evaluation is split into two areas: LTC20 in the London Borough of Havering, and LTC41N20 in Essex. Tables 1 and 2 reflect these areas but the rest of the pottery report treats the assemblage as a single site.

Results

- B.1.2 Some 52 sherds weighing 207g were found in 16 contexts from 13 trenches. Most of the material was flint tempered, some also containing sand; one sherd from context 2604 just contains sand, and one grog-tempered sherd came from context 3503. Only one sherd was diagnostic, from context 14909, and a sherd in context 7203 was decorated, although not in a chronologically unique style. Most of the dating was based on fabrics. Flint temper is ubiquitous in prehistoric pottery of most periods in the region making dating very difficult in the absence of diagnostic forms or decoration, and the spot-dates are therefore tentative. Sand is more prevalent in the Iron Age than the later Bronze Age in the region (Mucking: Brudenell 2016a, 160; 2016b, 380; South Hornchurch: Harrison 2000, 337-8), suggesting that sherds with sand might well be Iron Age, although as quantities were very small this is uncertain.
- B.1.3 Context 14906 produced an expanded rim with a groove. This is probably early Iron Age. Context 7203 produced a sherd decorated with parallel grooves, and this should be late Bronze Age or early Iron Age. Context 3503 produced a fine grog tempered sherd that might belong to a late Neolithic/early Bronze Age Beaker, although the other sherds from this context have been spot-dated to the late Bronze Age/early Iron Age and the grog tempered sherd is probably residual. No glauconitic sand was found in any of the sherds, suggesting that the middle Iron Age is not represented, although flint remained a common tempering agent into the middle Iron Age in the region and the size of the assemblage precludes meaningful interpretation of relative fabric proportions. It is possible some of the assemblage is as late as the middle Iron Age.

Context	Count	Weight (g)	Fabric	Spot-date	Comment
902	1	22	Flint, med	MBA-MIA	
1107	1	7	Flint, med	LBA-MIA	Smoothed
2604	5	12	Flint+sand, flint, sand	IA	
3503	23	31	Flint, med, sand and flint, grog, fine	LBA/EIA	1x grog sherd residual Beaker?
4902	2	2	Flint, med	Residual LBA-MIA	Also LIA pottery
4904	5	11	Flint, med	Residual LBA-MIA	Inc 2x sherds from enviro sample 3. Also LIA pottery
7203	3	20	Flint, fine	LBA/EIA	Decorated with parallel lines/grooves. Burnished
10403	1	5	Flint and sand	LBA-MIA	Base
Total	41	110g			

Table 1: Prehistoric pottery from LTC20

Context	Count	Weight (g)	Fabric	Spot-date	Comment
14906	1	35	Flint, coarse	EIA	Expanded rim with groove
15704	1	4	Flint, med	MBA-MIA	
15707	1	3	Sand+flint, fine	LBA-MIA	
15709	1	8	Flint+sand, med	LBA-MIA	
15808	1	8	Flint, med	MBA-MIA	
18008	1	3	Flint, med	MBA-MIA	
29811	1	6	Flint+sand, med	LBA-MIA	
33503	4	30	Flint, med	MBA-MIA	Plain tapering vertical rim. Not clearly diagnostic
Total	11	97g			

Table 2: Prehistoric pottery from LTC41N20

B.2 Late Iron Age and Roman Pottery

By Edward Biddulph

Introduction

B.2.1 Forty-eight sherds of late Iron Age and Roman pottery were recovered from the evaluation. The small assemblage was quantified by sherd count and weight in grammes. Fabrics from LTC20 were given Museum of London Archaeology codes (Table 3; MOLA 2014a), while fabrics from LTC41N20 were assigned codes devised by the Essex County Council Field Archaeology Unit (Table 4; cf. Biddulph *et al.* 2015).

Results

- B.2.2 This evaluation is split into two areas: LTC20 in the London Borough of Havering, and LTC41N20 in Essex. The tables in this report reflect these areas but the rest of the report treats the assemblage as a single site.
- B.2.3 Late Iron Age or early Roman activity is indicated by the presence of grog-tempered ware (GROGC) in Trenches 254, 294 and 298, and South Essex shell-tempered ware (SESH) in Trench 1. Finer grog-tempered pottery (GROG) was recovered from ditch 4903 in Trench 49 but was found in association with oxidised sandy ware (OXID), dating deposition to the early Roman period or later. Most sherds given fabric code OXID were probably from the same vessel. One of the grog-tempered sherds from ditch 4903 was from a relatively straight-walled vessel decorated with multiple finger-impressed cordons. The sherd may belong to a carinated bowl (eg Thompson 1982, type E1-2), but identification remains uncertain.
- B.2.4 Early or middle Roman activity is indicated by pottery recovered from Trenches 271 and 277. The former contained a sherd of North Kent grey ware (NKG), which dates between the mid-1st and mid-3rd century AD, while a fragment of Highgate Wood C ware (HGG) was collected from the latter. This dates from the late 1st to mid-2nd century AD.
- B.2.5 The latest piece was a sherd of Hadham oxidised ware (HAX) from Trench 343. This was deposited in the 3rd or 4th century AD or later.
- B.2.6 Trenches 173, 187, 235, 284 and 339 and 347 contained pottery that could not be dated closely within the Roman period. Sherds in an oxidised sandy fabric (RED), sandy grey ware (GRS), and black-surfaced ware (BSW) were identified, the last including part of a lid rim.
- B.2.7 In general, the assemblage comprises small and abraded sherds, which is reflected in a mean sherd weight (weight divided by number of sherds) of 5.6g. The condition and size of the assemblage suggest that the material had undergone several episodes of redeposition and had been deposited incidentally, perhaps away from the focus of pottery use and initial discard.
- B.2.8 The pottery points to late Iron Age/early Roman or later Roman activity in the vicinity of the site. A degree of spatial patterning is evident, with the pottery from the northern part of the site (LTC20) being of late Iron Age/early Roman or early Roman in date, and the pottery from the southern and south-eastern parts of the site (LTC41N20) having a wider date range, from late Iron Age/early Roman to middle/late Roman.

Given the very small quantities of pottery recovered from these areas, however, any conclusions drawn from such an observation must be regarded as uncertain.

Recommendations regarding the conservation, discard and retention of material

- B.2.9 The pottery reported on here has the potential to inform future research through re-analysis and thus it is recommended that all the pottery is retained. This follows the advice set out in the 'Standard for Pottery Studies in Archaeology' (PCRG, SGRP, MPRG 2016).

Context	Fabric	Description	Count	Weight (g)	Spot-date
103	SESH	South Essex shell-tempered ware. Very abraded thick-walled body sherds. Moderate/sparse grog and flint also in fabric. Sherds probably part of single vessel	3	32	20 BC-AD 120/50
105	SESH	South Essex shell-tempered ware. Very abraded sherds. 2x dark grey fabric with possible additional black grog inclusions. 1x larger angled base sherd in orange-brown fabric with additional organic, flint, grog, and quartz inclusions	3	44	20 BC-AD 120/50
	SESH	Sample 4. South Essex shell-tempered ware; fabric as dark grey sherds above	2	4	
4902	GROG	Grog-tempered ware (SOB GT). One sherd decorated with finger-impressed cordons	2	6	AD 43-70
	OXID	Miscellaneous oxidised wares	9	27	
4904	GROG	Grog-tempered ware (SOB GT)	1	3	AD 43-70
	OXID	Miscellaneous oxidised wares	5	13	
Total			25	129	

Table 3: LTC20 – Quantification of late Iron Age and Roman fabrics (codes in brackets from Tomber and Dore 1998)

Context	Fabric	Description	Count	Weight (g)	Spot-date
17306	GRS	Sandy grey ware body sherds	3	23	AD 43-410
18704	GRS	Sandy grey ware body sherd	1	3	AD 43-410
23514	RED	Miscellaneous oxidised ware	1	4	AD 43-410
25406	GROGC	Coarse grog-tempered ware (SOB GT)	3	47	50 BC-AD 70
27106	NKG	North Kent grey ware (UPC FR)	5	5	AD 50-270
27704	HGG	Highgate grey ware (HGW RE C)	1	1	AD 70-160
28404	BSW	Black-surfaced ware, rim of lid, EVE = 5%	1	15	AD 43-410
29401	GROG	Grog-tempered ware (SOB GT) body sherd	1	5	50 BC-AD 70
29809	GROG	Grog-tempered ware (SOB GT), neck fragment	1	8	50 BC-AD 70
	UPOT	Unidentified pottery. Amorphous, burnt fragment, sandy	1	9	
33907	GRS	Sandy grey ware body sherds	2	17	AD 43-410
	GRS	Sample 13. Sandy grey ware body sherd	1	2	
34304	HAX	Hadham oxidised ware (HAD OX) body sherd	1	1	AD 200-410
34705	RED	Miscellaneous oxidised ware body sherd	1	1	AD 43-410
Total			23	141	

Table 4: LTC41N20 – Quantification of late Iron Age and Roman fabrics (codes in brackets from Tomber and Dore 1998)

B.3 Medieval Pottery

By John Cotter

London Borough of Havering (LTC20)

- B.3.1 A total of 154 sherds of medieval and post-medieval pottery weighing 2042g were recovered from 9 contexts. These include 16 sherds (91g) from sieved samples from three contexts (treated as separate records). Ordinary domestic wares were recovered. A range of pottery from perhaps the 10th century through to the 19th century was identified. Nearly all of this, however, is medieval.
- B.3.2 All the pottery was scanned during the present assessment and spot-dates were provided for each context. Each context group was quantified by sherd count and weight and recorded on a spot-dating spreadsheet. The pottery is in a very fragmentary and abraded condition.
- B.3.3 The context spot-date is the date-bracket during which the latest pottery types or fabrics are estimated to have been produced or were in general circulation. Comments on the range of fabrics were recorded, usually with mention of vessel form (jugs, bowls etc.) and any other attributes worthy of note (eg. decoration etc.). Fabric codes referred to are those of the Museum of London (MoLA 2014). Where appropriate, these are cross-referenced to the fabric codes used by Essex County Council (Cotter 2000, 12-13). The range of pottery is described in some detail in the spreadsheet (Table 5) and is therefore only summarised below.

Context	Spot-date	Count	Weight (g)	Comments
503	c 1270-1350	8	94	7x Mill Green coarseware (MG COAR). Fresh sherds. Include rim from globular pipkin/skillet with a pulled lip and body sherd from same vessel with typical clear yellow glaze on lower wall int. Includes 3 in reduced grey MG COAR fabric with more fine flint, including a sagging cookpot base with traces of yellow glaze on base int. Most of sherds sooted ext. 1x fresh bo (body sherd) South Essex shellyware (SEMS) cookpot
503	c 1270-1350	13	75	Sieved Sample <6>. 13x Mill Green coarseware (MG COAR). Includes flanged horizontal rim from cookpot. Also sagging base sherds
506	c 1100-1300/25?	21	231	All South Essex shelly ware (SEMS, c 1100-1300). Might be to c 1350 if contemporary with MG COAR? Fresh cooking pots incl 8-9 joining sherds from smallish cookpot with sub-squared rim. Mostly sooted ext
506	c 1100-1300/25?	2	6	Sieved Sample <7>. 2x bos SEMS shelly ware
508	c 1270-1350	2	4	Small worn bos MG COAR
703	c 1300-1400?	5	100	All fine fully developed Mill Green ware (MG) with smooth fabric and no flint. 4x unglazed bos possibly from same globular jar or jug? Fresh but with weathered ext surface. 1x hollow pedestal-like base from a chafing dish - fine dense MG fabric (possibly late MG? or early post-medieval redware PMR/ Essex Fabric 40EA from, c 1475+?). Latter

Context	Spot-date	Count	Weight (g)	Comments
				has distinct grey core with red clay pellets, ext surface covered with clear orange-brown glaze
1302	c 1250-1300?	48	908	Fresh sherds. Mostly 2-3 broken cooking pot profiles (c 37 sherds) in a brown sand-free shelly ware with abundant dissolved shell, rare quartz grains, rare angular flint in soft smooth matrix with v fine mica; probably South Essex shell-tempered ware (SEMS, c 1100-1300/ Essex Fabric 12A/B?), includes 5 rims of developed squarish form, poss wheel-turned. Sooted ext. 1x weathered neck sherd from unglazed jug with stub of strap handle showing start of stab or slash marks on top of handle, handle thumbled join to neck, neck showing slight horiz grooving; uncertain fabric - very smooth/sand-free, orange-brown matrix like the shelly ware and with moderate grey-brown clay pellets or grog and v rare shell plus fine organic inclusions - most like Mill Green ware (MG, c 1270-1350, but poss an earlier versions c 1250+?). 10x fresh sagging base and bos from 1-2 cookpots (probably wheel-turned) in fine sandy orange fabric with moderate angular flint up to 2mm, rare shell: probably Mill Green coarseware but much coarser than usual (MG COAR, c 1250-1350) or something more local?
1303	c 1250-1300?	33	538	Context possibly of mixed date? 2x small bos Mill Green ware (MG) incl abraded bo possibly from same jug in 1302(?) but this bo has decayed specks of yellow glaze ext; the other bo from unglz cpot or jug? 11x fresh sherds flinty MG COAR (similar to 1302) but includes squared/flanged cpot rim with only rare flint. 13x smooth shelly ware (SEMS) as in 1302 incl thickened cpot rim. 11 sherds (= 1 early rounded jug) in coarse London-type ware (LCOAR, c 1080-1200) including complete joining strap handle frags and neck with rilled decoration; grey sandy fabric covered ext in a white slip under a mottled green glaze - the slip extends inside the neck; fabric contains coarse quartz inclusions, sparse flint and sparse shell; probably residual in this context (or a later local copy?)
4703	c 1000-1150?	20	74	Identifications uncertain - mostly small abraded bos (body sherds) of shelly wares (cooking pots?) with coarse platy shelly content all dissolved-out. Probably medieval but not impossibly LIA/Roman? Shelly wares mostly just shell in very fine clay matrix, or slightly sandy matrix, with rare flint and coarse rounded quartz inclusions - identification possibly early medieval shell-tempered ware (EMSH, c 1050-1150)? 2

Context	Spot-date	Count	Weight (g)	Comments
				sherds of latter retain a fair bit of circumference with a regular arc (1 with diam c 180mm) and sooted external surfaces - these might possibly be from wheel-turned vessels? If so, they might be late Saxon shelly ware (LSS, c 900-1050)? or Roman?? Some shelly sherds are sandier, with sparse flint (possibly EMSS - early med sand- and -shell-temp ware, c 1000-1150)? Latter incl 2 joining thicker sherds poss from a broken rim or base? 1x small jar base (weight 4g; flat/slightly sagging?) in a grey-brown sandy ware with sparse fine flint (Early med sandy ware - EMS, c 970-1100)? Broad spot-date of c 1000-1150 suggested
4904	c 1050-1150?	1	10	Sieved Sample <3>. Very abraded bo shelly ware (shell dissolved) with little sand (EMSH?)
6802	c 1805-1900	1	2	Bo refined whiteware (REFW)
TOTAL		154	2042	

Table 5: LTC20 - Description of post-Roman pottery by context

- B.3.4 The pottery comprises ordinary domestic wares typical of this part of south Essex and covers a date range possibly from the 10th century through to the 19th century.
- B.3.5 The very poor condition of the earliest pottery, however, makes positive identification to known fabric types uncertain. No rim sherds have survived - just small body sherds and one or two base sherds. Most of the early assemblage comprises similar-looking types of late Saxon or early Norman shelly wares – often with the shell content dissolved-out. These came from two contexts (mainly from 4703, also 4904). As far as can be determined, most of these appear to be early medieval shell-tempered ware (Fabric EMSH, c 1050-1150), but one or two sherds of late Saxon shelly ware (possibly wheel-turned?) might also be present (LSS, c 900-1050). A single sandy ware sherd has tentatively been identified as early medieval sandy ware (EMS, c 970-1100). A broad 11th-12th century dating is suggested for both contexts.
- B.3.6 The period best represented is the ‘high medieval’ period (13th to 14th centuries). The assemblage is dominated by a smooth shell-tempered ware which can very probably be identified as south Essex shellyware (London Fabric codes SEMS/Essex Fabric 12A/B). The London area dating for this is c 1100-1300, but this has been encountered on several other Essex sites, as here, in association with Mill Green ware jugs (MG, c 1270-1350) and may also have been in circulation as late as c 1350. It occurs here mainly in the form of cooking pots. Contexts (1302) and (1303) produced numerous sherds of SEMS including two or three reconstructable cooking pot profiles. These occur alongside a few jug sherds in Mill Green ware, and many more sherds in Mill Green coarseware (MG COAR, c 1270-1350, or possibly as wide as c 1250-1400?). The MG COAR also appears to be mainly from cooking pots and at least one globular pipkin/skillet form with a pulled lip/spout on the rim.
- B.3.7 There are many similarities between the range of high medieval period fabrics and vessel forms seen on this site and those from another nearby evaluation site in

Ockendon (LTC OCD 20). At both sites there is a high presence of shellyware SEMS vessels, Mill Green ware jugs (MG) and Mill Green coarseware (MG COAR).

- B.3.8 The largest high medieval contexts here, (503) (1302) and (1303), also produced numerous sherds of what appears to be a variant of MG COAR with moderate to abundant fine-medium flint inclusions (as well as the usual quartz sand). These also appear to be from cooking pots, and possibly jugs/pitchers, but no rims or handles were recovered. This variant has been noted previously on a few other sites in south-east Essex and may be worthy of further investigation if enough examples are identified from future excavations.
- B.3.9 Context (1303) also produced several sherds – including a complete handle from an early rounded jug in coarse London-type ware (LCOAR, c 1080-1200). This is probably of late 12th or early 13th century date and must be residual in this context.
- B.3.10 Context (703) produced a few unglazed sherds of Mill Green ware (MG) and a chafing dish (plate-warmer) base in the same fabric. This context has been spot-dated to c 1300-1400 but chafing dishes are more typical of the later 14th century onwards, so a late medieval date may be possible in this case.
- B.3.11 No definite post-medieval pottery was recovered from these contexts – apart from a single small sherd of 19th-century pottery from (6802).

Thurrock, Essex (LTC41N20)

- B.3.12 A total of 44 sherds of medieval and post-medieval pottery weighing 345g were recovered from 11 contexts. Ordinary domestic wares were recovered. A range of pottery from the early Anglo-Saxon period through to the 20th century was identified.
- B.3.13 All the pottery was scanned during the present assessment and spot-dates were provided for each context. Each context group was quantified by sherd count and weight and recorded on a spot-dating spreadsheet. The pottery is very fragmentary, but some fresh sherds are present.
- B.3.14 The context spot-date is the date-bracket during which the latest pottery types or fabrics are estimated to have been produced or were in general circulation. Comments on the range of fabrics were recorded, usually with mention of vessel form (jugs, bowls etc.) and any other attributes worthy of note (eg. decoration etc.). Fabric codes referred to are those of the Museum of London (MoLA 2014b). The range of pottery is described in some detail in the spreadsheet (Table 6) and is therefore only summarised below.

Context	Spot-date	Count	Weight (g)	Comments
21404	c 1720-1780	1	1	Staffordshire white salt-glazed stoneware (SWSG). Rim from small ointment pot/jar, or cup?
22405	c 1830-1900	2	4	1x body sherd (bo) Transfer-printed whiteware (TPW) with traces blue dec. 1x small very abraded bo (2g) fine greyware with brown surfaces/margins and with sparse coarse quartz and flint up to 1mm across; very thin-walled; probably Mill Green ware (MG, c 1270-1350; see similar in 29006)

Context	Spot-date	Count	Weight (g)	Comments
25104	c 1850-1950	3	30	1x small damaged ?cup footing in English porcelain (ENPO), plain white, probably 19C+. 2x sherds post-med red earthenware (PMR) flowerpot including fresh base frag with central hole, probably 19-20C
29006	c 1270-1350	12	127	2x Mill Green ware (MG) incl very abraded jug bo with traces of white slip-painted decoration and tiny patches of clear glaze. 5x sherds Mill Green coarseware (MG COAR, c 1270-1400) including broad cupped/lid-seated rim from a jar with int clear glaze, and thicker rim from unglazed bowl with horizontal flanged rim. 2x large fresh Essex-type shelly-sandy ware (SSWX, c 1100-1350?) = poss 1 vess incl sagging jar/cook pot base (sooted). 1x unident med shellyware, wheel-turned, cook pot shoulder in v fine/silty fabric with moderate shell - probably 13/14C? 1x bo coarse shellyware with no sand - poss early med shelly ware (EMSH, c 1050-1150)? 1x abraded bo sandy-shelly coarser with rare flint and organics - probably EMSS (c 1000-1150)?
29106	c 1100-1350?	2	4	Small abraded bos from 2 vess in shelly-sandy wares (1 with coarser sandy). Probably SSWX?
29406	5-7C	6	73	Probably Anglo-Saxon. Sherds from 2 vessels. 2 largest sherds (1 vess) from an abraded thick-walled vessel including a rounded/slightly angled base sherd: coarse sandy black fabric with moderate fine linear organic inclusions. Very hard/dense. Coarse rounded quartz and rare flint inclusions (London Fabric ESANF?). 4x joining small body sherds (1 vessel): fine silty-sandy fabric with sparse-moderate coarse organic inclusions, some mica. Black fabric with light brown ext surface. Fairly fresh (London Fabric ESAND? Or CHAF?)
29407	Prehistoric or Anglo-Saxon?	3	11	Probably pot. 3 abraded body sherds from same vessel. Very abraded ext but quite fresh internally with surface showing fine scratch-marks or fine linear organic inclusions? Fabric matrix/texture similar to 31604. Fine silty-sandy hard-fired brickearth. No flint. Poorly mixed/laminar. Some curvature of int surface. Dark grey fabric with small ext oxidised patches. Possibly Anglo-Saxon (London Fabric ESANAO?)? Or middle Bronze Age to Iron Age? (pers comm Alex Davies)
29804	c 900-1150?	2	5	1 vess. Incl possible basal angle and body sherd. All small. Soft dark brown fabric, soapy to touch. Coarse inclusions of platy shell - all dissolved-out. Shell inclusions all of very similar curved cross-section sometimes with a rectangular cross-section (otherwise possibly cereal husks/seeds?). Probably late Saxon shelly ware (LSS, c 900-1050), or early medieval shelly ware (EMSH, c 1050-1150)?

Context	Spot-date	Count	Weight (g)	Comments
31604	Prehistoric or Anglo-Saxon?	2	9	Pot? Or hard-fired FC? 2 joining pieces (fresh breaks). Very abraded flattish, slightly sherd-like. Hard. Fine silty matrix with sparse coarse angular/sub-angular flint and sparse rounded quartz grains. Black fabric with oxidised patch. Possibly Anglo-Saxon (London Fabric ESANF?)? Or middle Bronze Age to Iron Age? (pers comm Alex Davies)
33206	c 1850-1900	9	79	All 19C. Dish/plate rim and jug handle in transfer-printed whiteware (TPW). English porcelain mug rim with gilding (ENPO). Refined whiteware (REFW). 1x body sherd post-medieval red earthenware (PMR) possibly from a flowerpot?
34704	5-8C	2	2	1 vess. Bos from fine silty-sandy fabric vessl as in 29406. Probably Anglo-Saxon (London Fabric ESAND? Or CHAF?)
TOTAL		44	345	

Table 6: LTC41N20 - Description of post-Roman pottery by context

- B.3.15 The pottery mostly comprises ordinary domestic wares typical of this part of south Essex and covers a date range possibly from the early-mid Saxon period through to the late 19th or 20th century, though with some gaps evident.
- B.3.16 A few small abraded sherds of Anglo-Saxon pottery (5-7C or 5-8C?) were recovered from contexts (29406) and (34704). A few other sherds from contexts (29407) and (31604) are so small and abraded that they cannot be positively identified but are likely to be either prehistoric (mid Bronze Age to Iron Age?) or Anglo-Saxon.
- B.3.17 Two small shelly ware sherds, from the same vessel, occur in (29804). These are too small to positively identify but the coarse shell voids suggest they are either late Saxon shelly ware (LSS, c 900-1050), or early medieval shelly ware (EMSH, c 1050-1150).
- B.3.18 More certain medieval pottery includes two small abraded sherds of ?Essex-type shelly-sandy ware (Fabric SSWX? c 1100-1350), in context (29106). Larger sherds of cooking pots in this ware also occur in context (29006) together with several sherds of Mill Green ware (MG) jugs, and other forms, datable to c 1270-1350. The other four contexts produced a few sherds each of commonplace 18th-, 19th- and possibly 20th-century wares.

Recommendations for retention/disposal

- B.3.19 The pottery here has some potential to inform research through re-analysis and should be retained.

B.4 Flint

By Lawrence Billington

London Borough of Havering (LTC20)

Introduction and methodology

- B.4.1 A small assemblage of 12 struck flints and 183g (35 fragments) of unworked burnt flint were recovered during the evaluation.
- B.4.2 The assemblage was catalogued directly onto an Excel spreadsheet and the artefacts were classified according to a system of broad artefact/debitage types based on standard definitions for post-glacial lithic assemblages from southern Britain (e.g. Bamford 1985, 72-77; Healy 1988, 48-9; Butler 2005). Additional information on selected technological and non-metric attributes of the material (including platform type/preparation, hammer mode and dorsal cortex coverage) was also recorded using standard classifications and terminology based largely on those set out by Inizan and colleagues (1999).
- B.4.3 A basic quantification of the assemblage by context is provided in Table 7.

Context	Cut	Feature type	Sample	Irregular waste	Flake	Blade/let	Multiple platform core	Total worked	Unworked burnt count	Unworked burnt weight
103	102	Pit							3	80
203	202	Pit		1				1		
300	300	Ploughsoil			1			1		
404	403	Ditch				1		1		
500	500	Ploughsoil		1				1		
1100	1100	Ploughsoil		1				1		
1200	1200	Ploughsoil					1	1		
2300	2300	Ploughsoil			1			1		
2400	2400	Ploughsoil			1			1		
2900	2900	Ploughsoil			1			1		
4904	4903	Ditch	3						15	92
6803	6803	Other Layer	2						17	11
8403	8402	Ditch			1			1		
8601	8601	Subsoil				1		1		
10403	10402	Ditch			1			1		
Totals				3	6	2	1	12	35	183

Table 7: Quantification of the LTC20 flint assemblage

Results

- B.4.4 Pit 102, Trench 1, produced three fragments of heavily burnt flint weighing 80g. This material is not chronologically diagnostic but is likely to be of prehistoric date. A second pit (202) in Trench 2 produced a small fragment of undiagnostic irregular waste.

- B.4.5 Ditch 403 (Trench 4) produced a single small bladelet, likely to be of Mesolithic or early Neolithic date.
- B.4.6 Ditch 4903 (Trench 49) produced a 93g (15 fragments) of heavily burnt, unworked flint. A smaller assemblage of very heavily fragmented burnt flint (11g, 17 fragments) was recovered from the residues of a bulk sample taken from layer 6803 in Trench 68.
- B.4.7 Ditch 8402 (Trench 84) produced the proximal portion of a relatively fine tertiary flake, perhaps of Neolithic date. The distal end of a robust tertiary blade, exhibiting severe edge damage, was recovered from the subsoil of Trench 86 (8601) and is also likely to be of Neolithic date.
- B.4.8 A single flake was recovered from ditch 10402 (Trench 104). This is a simple hard hammer struck removal with a cortical striking platform.
- B.4.9 A total of eight struck flints were recovered from ploughsoil/subsoil deposits in Trenches 3, 5, 11, 12, 23, 24, 29 and 86. Most of these are simple hard hammer struck flakes, invariably with severe edge damage typical of lithic material recovered from ploughzone contexts. Some of the flakes, including those from Trenches 5, 24 and 29 may be plough struck as opposed to having been intentionally worked, and the only distinctive piece is a large plunging removal from Trench 3 (300), which has been struck from a trimmed striking platform, with its distal end removing a large portion of its parent core; this is likely to be of Mesolithic or Neolithic date. A single multiple platform core was recovered from the ploughsoil of Trench 12 (1200). This piece has been systematically worked and bears scars of some fine, blade-like removals and it is unlikely to postdate the Neolithic.

Discussion

- B.4.10 Given the scale of the evaluation the flint assemblage can only be considered very small and of limited significance. It seems likely that all of the struck flints derived from cut features represent residual finds incorporated into later deposits. Together with the material collected from ploughsoil/subsoil deposits they attest to some low-level prehistoric activity at the site. The burnt flint may also be of prehistoric date, but it was recovered in relatively low densities and may simply represent material inadvertently caught up in hearths or other fire settings during any period of the site's use. The one exception to this is the three burnt flints (80g) from Pit 102, which may be contemporary with the feature from which they derive.

Thurrock, Essex (LTC41N20)

Introduction and methodology

- B.4.11 A total of 22 worked flints and 474g (84 fragments) of unworked burnt flints were recovered from the evaluation.
- B.4.12 The flint was catalogued directly onto an Excel spreadsheet and the artefacts were classified according to a system of broad artefact/debitage types based on standard definitions for post-glacial lithic assemblages from southern Britain (e.g., Bamford 1985, 72-77; Healy 1988, 48-9; Butler 2005). Additional information on selected technological and non-metric attributes of the material (including platform type/preparation, hammer mode and dorsal cortex coverage) was also recorded using standard classifications and terminology based largely on those set out by Inizan and colleagues (1999).

B.4.13 A basic quantification of the assemblage by context is provided in Table 8.

Context	Cut	Feature type	sample	chip	flake	blade like flake	blade	opposed platform core	single platform balde core	end scraper	Total worked	unworked burnt	unworked burnt
11903	11903	Subsoil				1					1		
13505	13503	Pit	3									40	138
13508	13507	Pit	4									35	229
15709	15708	Ditch			1						1		
16308	16307	Ditch			1						1		
16800	16800	Ploughsoil			1						1		
18400	18400	Ploughsoil					1				1		
23517	23515	Ditch			1						1		
24604	24603	Pit										2	10
29400	29400	Ploughsoil			1						1		
29804	29803	Ditch										3	31.3
31004	31003	Ditch					1				1		
31500	31500	Ploughsoil			1						1		
31604	31603	Ditch			1	1	2	1			5	1	23
31606	31605	Ditch			1						1		
33503	33502	Pit			1						1		
33505	33502	Pit										2	19.6
33803	33802	Ditch										1	22.9
33900	33900	Ploughsoil			1						1		
33907	33906	Ditch					1				1		
34301	34301	Subsoil							1		1		
34302	34302	Natural			1						1		
34307	34306	Natural Feature		1							1		
34600	34600	Ploughsoil							1		1		
Totals				1	11	2	5	1	1	1	22	84	473.8

Table 8: Quantification of the LTC41N20 flint assemblage

Worked flint

B.4.14 The 22 worked flints were recovered from 18 individual contexts, with nine deriving from the fills of cut features and the remainder coming from ploughsoil, subsoil and natural deposits. The flint was recovered in very low densities and only one individual context/feature produced in excess of a single piece – the fill (31604) of ditch 31603, Trench 316, which contained five struck flints.

B.4.15 The flint is generally of good quality, with surviving cortical surfaces suggesting the exploitation of small rounded to sub rounded cobbles derived from secondary gravel sources. The colour of the flint varies considerably, but there a relatively large number of pieces of a distinctive opaque brown flint, which is more common among the earlier, blade-based material recovered from the site (see below).

B.4.16 Most of the struck flint exhibits at least minor edge damage/rounding, and many of the pieces recovered from ploughsoil/subsoil deposits bear some severe edge damage. Cortication is rare and is restricted to a light clouding/sheen on a few pieces.

- B.4.17 The assemblage is overwhelmingly dominated by unretouched removals, alongside a single retouched tool and two cores. It includes a high proportion of blade-based material of Mesolithic/earlier Neolithic date. Blades and blade-like removals make up almost 40% of unretouched removals (7 of 18), and both cores and the single retouched piece also derive from blade-based technologies. Individual blades/blade like flakes were recovered from ditches 31003 and 33906 and from ploughsoil/subsoils in Trenches 184 (18400) and 119 (11903). Most notable, however, are two blades, a blade like flake and an opposed platform blade core from the fill of ditch 31603. Although the flint from this feature is in a condition consistent with representing residual material, all the blade -based material is made of a similar opaque brown flint, and it is even possible that some pieces derived from the same nodule/core (although no refits could be made). The opposed platform core (47.6g) has two offset striking platforms, both prepared by careful platform edge trimming, and bears some cresting along one side, undertaken to control the morphology/convexity of the main flaking face.
- B.4.18 The second core from the site, a small single platform blade core (43.5g), came from the subsoil of Trench 343 (34301). The only retouched tool is an end scraper, recovered from the ploughsoil of Trench 346 (34600). This tool is made on a relatively large, robust, non-cortical blade which has been (minimally) retouched at its distal end to provide a steep, convex, scraping edge.
- B.4.19 The remainder of the worked flint consists of unretouched flakes, few of these are distinctive and whilst some are likely to represent the less characteristic products of Mesolithic/earlier Neolithic flintworking, most is likely to be of somewhat later date, relating to later Neolithic and Bronze Age activity.

Unworked burnt flint

- B.4.20 The majority of the burnt flint was derived from two pits (13503 and 13507) in Trench 135 which produced a combined total of 367g of heavily burnt and highly fragmented flint (75 fragments; mean clast weight 4.9g). Much smaller quantities (one to three fragments, up to 31g) were recovered from the fills of pits 24603 and 33502 and ditches 29803, 31603 and 33802.

Discussion

- B.4.21 Given the scale of the evaluation the flint assemblage can only be described as small, and the worked flint appears to derive exclusively from either unstratified contexts or to represent residual material caught up in later features. Nonetheless, the flintwork does provide evidence for prehistoric activity across the site, and the high proportion of blade-based material is particularly notable. Some of this may reflect activity in the earlier part of the Neolithic period, but the opposed platform core from ditch 31603 is of a kind much more characteristic of Mesolithic technologies, and the regularity of the majority of the blade-based removals also suggests that most of these are likely to be of Mesolithic date.
- B.4.22 The burnt flint is also likely to be of prehistoric date, and in the case of the assemblages from the two pits in Trench 135 may be broadly contemporary with the features from which it derives.

B.5 Ceramic building material and fired clay

By Cynthia Poole

Introduction

- B.5.1 A large quantity of ceramic building material (CBM) was recovered from sites LTC20 and LTC41N amounting in total to 298 fragments weighing 13kg together with 18 small fragments of fired clay (104g). The CBM assemblage includes some fairly large fragments, though no complete items were recovered, and the mean fragment weight of 43g is relatively low reflecting the fragmentation of much of the brick, which was soft and fairly abraded. The assemblage is focused on the early post-medieval late 15th-16th century, though fragments of field drain represent 19th century agricultural improvement. The assemblage has been spot dated and recorded on an Excel spreadsheet in accordance with guidelines set out by the Archaeological Ceramic Building Materials Group (ACBMG 2007). Fabrics were characterised on the basis of macroscopic features supplemented by the use of x20 hand lens for finer constituents. Where possible, fabrics have been allocated to Museum of London (MoL) fabric codes (MOLA 2014c).

Fabrics

- B.5.2 The majority of roof tile is made in a hard, orange - red fine sandy fabric with fine moulding sand that equates to MoL fabric 2276, which is dated in London to 1480-1800. The brick is all made in a softer more powdery orange red fine sandy fabric containing a moderate density of medium-coarse quartz and red iron oxide sand and a scatter of flint grits 5-19mm in size. This is identified as MoL 3030 fabric, dated to 1400-1660. At this site this fabric probably represents local production, possibly supplying a single building event.

LTC20

- B.5.3 The CBM and fired clay from this area amounted to 252 fragments weighing 9595g and was recovered mainly from Trenches 9, 68 and 77 with lesser amounts from Trenches 7, 11, 13, 32, 47, 84, 104 and 107 (Table 9).
- B.5.4 Brick (217 fragments, 8110g) dominated the assemblage and comprised several large pieces including two half bricks. These measured 55-57mm ($2\frac{1}{8}$ "- $2\frac{1}{4}$ ") thick by 130mm (5") wide and 55-59mm ($2\frac{1}{8}$ "- $2\frac{1}{4}$ ") thick by 125mm ($4\frac{7}{8}$ ") wide. Other more fragmentary pieces measured 47 ($1\frac{15}{16}$ "), 50, 51 (2"), 57-61mm ($2\frac{1}{4}$ "- $2\frac{3}{8}$ ") and 62mm ($2\frac{7}{16}$ ") thick and 115mm ($4\frac{1}{8}$ ") and 125mm ($4\frac{7}{8}$ ") wide. The maximum surviving length of any brick was 140mm. Most of the bricks have a fairly smooth or even upper surface and are generally fairly regular, though edges are rough and often creased and bases vary from fairly even to rough and irregular and corners and arrises were rounded. A number of fragments had a thick silvery grey vitrified coating to the surface, which resulted during firing of the bricks based on the pattern of unvitified areas created by the adjacent bricks stacked on them. This may have been a deliberate feature to create flared headers for diaper work.
- B.5.5 The overall character and size of the bricks is very similar to examples found at Hampton Court Palace classified in the brick typology as type A (Ford 1991), where they found in structures relating to buildings assigned to Cardinal Wolsey or earlier and are dated to the first quarter of the 16th century.

- B.5.6 A single narrow paving brick (201g) measured 73 [2 $\frac{7}{8}$ ""] wide and over 36mm thick and had a finely striated surface wiped smooth and rough edges. It was found in the kiln 6808 and is the same fabric as the standard bricks. The size is similar to Dutch clinker bricks (Smith 2001, 34), and though the fabric clearly shows this to be a local product, it is possible it had the same intended function to be used in paving.
- B.5.7 Roof tile (13 fragments, 234g) comprised predominantly flat rectangular roof tile measuring 12-14mm thick generally with a fairly regular finish. One piece retained evidence of a square peg hole 10mm wide and it is probable all the flat roof tile was of peg tile form. Square peg holes are most commonly a feature of late medieval – early post-medieval roof tile. A single curved ridge tile 15mm thick was neatly finished.
- B.5.8 Field drain is represented by three small, curved sherds (48g) made in a red-dark red sandy fabric, somewhat coarser than the roof tile. They measure 14 and 15mm thick and 60 and 80mm in diameter. Both appear to be handmade rather than machine made, suggesting a date in the first half of the 19th century.

Context	Spot-date	Count	Weight (g)	Form	Comments
103	Preh-Med	1	17	Fired clay	
703	Pmed	1	21	Roof	
902	MC15-C16	5	586	Brick	
1104	?C19	1	5	?Field drain	
1107	PMED	1	2	Chip	
1305	PMED	1	22	Roof	
2804	MC15-C16	6	371	Brick	
3208	Pmed	4	76	Brick, Roof	
4703	Pmed	3	35	Brick?, Ridge	
6802	MC15-C16	35	3715	Brick, Paving brick?, Roof	
6803	MC15-C16	9	127	Brick	
7203	~	2	7	Fired clay: Indeterminate	amorphous
7703	MC15-C16	26	355	Brick	
7704	MC15-C16	110	1980	Brick	
7707	MC15-C16	37	2150	Brick	
8403	C19	3	53	Roof, Field drain	
10403	Pmed	1	2	Indeterminate/Brick?	
10703	Pmed	3	12	Brick, Roof	
10707	C19?	6	83	Peg tile, ?Field drain (curved tile)	
Total		255	9619		

Table 9: LTC20 - Summary of CBM assemblage

LTC41N20

- B.5.9 The CBM from this area forms a smaller group comprising 46 fragments weighing 3215g) from Trenches 112, 208, 214, 235, 238, 254, 294, 312, 314, 319, 332, 339 and 343. Ten fragments of fired clay (33g) were recovered from Trenches 149 and 246 (Table 10).
- B.5.10 Brick was the dominant form recovered (19 fragments, 1773g) and included a half brick from ditch 11202. This measured 57-62 [2 $\frac{1}{4}$ "-2 $\frac{3}{8}$ ""] thick by 125 [5"] wide and over 165mm long and was fairly roughly finished. All other pieces were small and fragmentary with no complete dimensions surviving. The half brick was the same size and of similar characteristics to those found in the LTC20 area.

- B.5.11 Post-medieval flat rectangular roof tile (13 fragments, 303g) measured 12-14mm thick and had a fairly smooth upper surface, though one was rather lumpy and rough bases. One had a circular peg hole 10mm diameter with a slight thickening of the tile around its base. The roof tile was moderately to heavily abraded and the four edges recorded were rough and worn.
- B.5.12 One fragment (30g) from pit fill 24907 was made from a very fine sandy fabric with occasional ferruginous specks <1mm. This had a smooth even upper surface with a slight curve at one end. It is possible that this may have formed part of a medieval/post-medieval ridge tile in a very smooth, fine fabric.
- B.5.13 A broken field drain (13 fragments, 1082g) was recovered from ditch fill 23515. Although only three fragments could be refitted, these are clearly all part of a single drain tile made in a distinctive dark purplish red fabric containing frequent medium quartz sand and coarse angular unwedged cream clay pellets up to 10mm. It measures 19mm thick and 110-120mm in diameter, which equates with a standard 4" diameter. The surfaces are variously smooth in some areas and rough and striated in others on both the inner and outer surface, that suggests the tile was machine extruded, but that the process dragged out a lot of the coarse clay pellets resulting in the rough finish. Two pieces had roughly cut flat ends. The rough finish suggests this may be a fairly early example of machine extruded drain tiles probably of mid-19th century date. One other curved fragment (51g) of probable field drain was recorded from ditch fill 31203. This was made from a similar fabric, had one cut end and on the inside was a groove measuring 3.8mm wide and 103mm long, probably a coarse striation made by the extruding machine dragging a large grit down the surface.
- B.5.14 An amorphous fragment (3g) from ditch fill 33907 was made from a fine fabric similar to the roof tile, but soft and abraded, which is more typical of brick. It had no diagnostic features, and its dating is therefore uncertain.

Context	Spot-date	Count	Weight (g)	Form	Comments
11203	MC15-C16	1	1395	Brick	Half complete
14904	Preh-Med	4	7	Fired clay: Indeterminate	Flat surface
20808	MC15-C16	2	30	Brick	
21404	MC15-C18	1	25	Roof: flat	
23517	C15-C18 and MC19	18	1151	Peg tile, Brick, Field drain tile	Circular peg hole 10mm dia
23804	MC15-C18	2	30	Roof: flat, Brick	
24604	Preh-Med	6	26	Fired clay: Indeterminate	amorphous
25408	MC15-C16	2	14	Brick	
29407	Med/Pmed?	1	30	Roof: ridge?	Slight curve at one end. Possibly a med/post-med ridge tile in a very smooth fabric?
31203	C19	1	51	Field drain tile	Possibly crudely extruded.
31203	PMed	6	105	Brick	Highly abraded brick frags. Four worn surfaces
31207	PMed	1	5	Roof: flat	Possible roof tile
31209	PMed	1	9	Brick	Highly abraded brick frag

Context	Spot-date	Count	Weight (g)	Form	Comments
31403	MC15-C18	2	37	Roof: flat	Two abraded roof tile frags.
31901	PMed	2	165	Brick	Highly abraded brick frags. Three very worn surfaces - two of these are at right angles
33206	C18-19	5	124	Roof: flat	Five roof tile frags. One frag has a slight curve could be part of a ridge tile.
33907	Undated	1	3	Unidentified	Shapeless abraded scrap. Very soft and smooth
34305	PMed	1	44	Roof: flat	Possibly 17-19C? squared-off. Patches of grime
Total		57	3251		

Table 10: LTC41N20 - Summary of CBM assemblage

Fired clay

- B.5.15 Small quantities of fired clay were recovered from both areas (3 fragments, 24g from LTC20 and 15 fragments, 80g from LTC41N20). All were indeterminate, amorphous fragments 5-30mm in size except for one piece with a flat deliberately shaped surface. All but one piece was made in a pinkish brown, pale pink or orange fine-medium sandy clay. A piece from context 29811, a fill of pit 29810, was in a hard, dark grey fabric, probably having been burnt. Neither date nor function can be determined from any of the pieces, though the fragments from fill 7203 were probably debris from the burnt lining of the hearth/oven base 7202. The piece from pit 29810 may also have derived from a hearth or oven.

Conclusions

- B.5.16 The CBM assemblage forms a significant group of material. Brick forms the dominant component and this all appears to be fairly uniform in date, of late 15th-16th century. The roof tile is more difficult to date, but the presence of a square peg hole on one piece suggests it may be broadly contemporary. The brick, concentrated in trenches 68 and 77 in the northern part of Land Parcel 41, relates to industrial activity present on the site. This is represented by a circular brick-built kiln 6808, which was partially excavated. This was interpreted on site as a brick kiln, but this is unlikely and it is probable that this is a brick built lime kiln. A circular brick built lime kiln is known from Beaulieu Park, Essex (Stocks-Morgan 2017a), where a double flued flare kiln was constructed in typical Tudor bricks of late 15th-16th century date. A lime kiln of slightly later 16th-17th century date, oval in form with a single flue was found at Bracknell, Berkshire (Simmonds *et al* 2009, 33-7). In addition to the kiln quantities of brick were found in spread layers (6803, 7707) containing charcoal, described as occupation layers and also in gully 7702. These may represent waste debris from the kiln, but an alternative interpretation is that these formed the remains of brick clamps. Whilst roof and floor tile were fired in kilns, bricks were more commonly fired in brick clamps prior to the 19th century.

- B.5.17 The potential presence of brick production in the area was noted in the WSI based on the field name 'Brick Kiln Field' (No. 1811) on a 1775 estate map. This may refer to the kiln built of brick found in the evaluation, but it could have wider implications of brick production that took the form of brick clamps as indeed indicated by the earlier field name of 'Brickclamps'. The later name may reference the brick-built kiln, which would possibly have remained visible for longer than the clamps, which leave a much more ephemeral trace on the surface of the natural substrate. The bricks used to construct the kiln were almost certainly made and fired in the vicinity in brick clamps. Brick clamps of Tudor date are known from Hampton Court Palace (Ford *et al* 2014) and Beaulieu Park (Stocks-Morgan 2017b) and at both sites several clamp bases were exposed. The impetus for the industrial activity exposed in the evaluation may relate to the construction of North Ockendon Manor, situated to the north-east of the site, which is recorded as a red brick-built building of 16th century origin (VCH 1978, 110-117): the CBM is consistent with such a date for this activity and the presence of vitrified surfaces suggestive of the production of flared headers for decorative diaper brickwork is also typical of this period. A small quantity of mainly post-medieval brick and tile, 21 fragments (573g) was also recorded in Trenches 294, 312, 314, 319, 332, 339 and 343 (the eastern part of Land Parcel 60).
- B.5.18 The former later medieval or early post-medieval moated manor of Groves was located just east of Land Parcel 60, and just outside the site. The only remains of this manor house is a listed brick gateway (1147431) dated late 16th-early 17th century, located 100m north-east of Land Parcel 60. This manor may have been established c 1531 when the manor of Bruyns (South Ockendon Hall) was split or it may have been in existence prior to this. This manor house was surrounded by a moat and was extant until at least c 1772, but was demolished soon after. In the 19th century, farm buildings were built just north of Land Parcel 60 and were labelled as Groves Farm on later 19th century OS maps (VCH 1978, 117-126). It is possible that the brick and tile from this field may have originated from the later medieval or early post-medieval Groves manor house. A fragment of extruded 19th century field drain was also recorded from the eastern part of Land Parcel 60 (context 31203). This may relate to agricultural activity associated with Groves Farm.

Recommendations for retention/disposal

- B.5.19 The value of the assemblage is in providing evidence of significant industrial activities taking place on site together with dating evidence for this activity. In addition, it may be possible to link the activity in the northern part of the site to the lost manor house of North Ockendon. The material has additional intrinsic research value in providing evidence of the clay fabric used for brick production in the 16th century in this locality. In addition, the brick and tile fragments recorded in the eastern part of the site may be associated with the lost early post-medieval manor of Groves. This manor house was located just east of Land Parcel 60 and was demolished in the late 18th century.
- B.5.20 It is not necessary for all the brick or tile to be retained and some of the small amorphous rubble has already been discarded, but all the better preserved pieces should be retained. Recommendations or action taken with regard to discard is indicated in the archive record. Should further excavation be undertaken, and better preserved material recovered, only then should further discard be considered.

B.6 Metalwork

By Anni Byard

Introduction and methodology

- B.6.1 A total of 30 iron objects weighing 579.8g plus a single copper alloy object weighing 2.5g were recovered from seven contexts (Table 11).
- B.6.2 All small finds were scanned during the present assessment and where possible century or broad period dates were assigned. Objects were quantified by type count and weight by context and recorded on a spreadsheet.

Description

Context	Material	Count	Weight	Object	Date
503	Fe	1	5	Nail?	Query
10403	Fe	1	7.4	Nail?	Query
11204	Fe	1	11.2	Cartridge	Modern
17710	Fe	4	62	Query	Query
19804	Fe	1	3.8	Nail	Query
20808	Fe	1	10	Nail	Query
20808	Fe	1	26.7	Sheet	19-20th C
22405	Fe	1	178	Query	19-20th C
23514	Fe	3	44.6	Query	Query
23804	Fe	1	7.8	Query	Query
23804	Fe	11	9	Nail	19-20th C
23804	Fe	2	35.9	Sheet	Query
23804	Cu alloy	1	2.5	Nail	19-20th C
33206	Fe	1	15.3	Nail	19-20th C
33206	Fe	1	168	Strap bar	19-20th C

Table 11: Catalogue of metal objects by context

Discussion

- B.6.3 Much of the iron is heavily encrusted, and this has restricted interpretation and potential dating although it is likely to be post-medieval or modern in most cases.
- B.6.4 The only identifiable iron object is the cap of a shotgun cartridge, dating from the second half of the 20th century.
- B.6.5 A rounded iron bar recovered from Trench 332 may be a hinge strap or similar. Like most of the iron assemblage its condition negates certain identification.
- B.6.6 A single copper alloy nail was recovered from context 23804 (fill of ditch 23803). This is of probable 19th or early 20th century date. Copper nails were favoured in buildings where a sparking iron nail could be catastrophic, such as in a flour mill or ammunitions store. This object provides an indicator of date for the iron artefacts from this context.

Recommendations for retention/disposal

- B.6.7 The identification of some of the assemblage may be aided by x-radiography. This in turn may refine dating. In its current state the ironwork holds little value but should be retained for consideration against any other material should further works occur. If no

further work is planned the ironwork could be discarded after x-radiography has been conducted. The single copper alloy nail is of more intrinsic interest and should be retained.

B.7 Glass

By Anni Byard

Introduction

- B.7.1 Thirteen shards of glass weighing 221.3g were recovered from five contexts during the evaluation (Table 12).
- B.7.2 The glass assemblage was scanned during the present assessment and where possible century or broad period dates were assigned. Objects were quantified by type count and weight by context and recorded on a spreadsheet.

Context	Material	Count	Weight (g)	Object	Date
3208	Glass	3	100.2	Milk Bottle	Early 20th C
3208	Glass	4	21.5	Milk Bottle	Early 20th C
3208	Glass	1	46.7	Beer Bottle	Late 19th / early 20th C
8403	Glass	1	8.5	Wine Bottle	P-med / modern
21404	Glass	1	5.7	Bottle	?
22405	Glass	1	33.5	Beer Bottle	Late 19th / early 20th C
22405	Glass	1	0.4	Decorative	Late 19th / 20th C
22405	Glass	1	2.5	Window	Early 20th C
Total		13	219		

Table 12: Catalogue of glass by context

Discussion

- B.7.3 Three separate fragmentary and incomplete glass vessels were recovered from context 3208. Seven shards represent the remains of two clear milk bottles, one of which is embossed with HOWARD'S DAIRIES below the remains of the lip. Both bottles are probably of early to mid-20th century date. The third vessel from this context survives only as an incomplete base shard. This is light blue/green (aqua) in colour and is probably from a beer or soda bottle. It is embossed with CASTLER[...A]D[...] just above the base but its meaning could not be deciphered. The bottle is of later 19th or early 20th century date (c 1850-1950).
- B.7.4 A small olive-green glass shard from context 8403 is probably from a wine bottle of later post-medieval or modern date.
- B.7.5 A heavily weathered probable wine bottle shard (5.7g) was recovered from context 21404. The weathering has resulted in a gold-coloured patination that completely obscures the underlying glass. The bottle is of late 19th or early 20th century date.
- B.7.6 Three shards of glass recovered from context 22405 weighed a total of 36.4g. These comprised the remains of a beer or soda bottle (33.5g) with an opaque light aqua hue, a piece of float window glass 2.8mm thick (2.5g), and a thin (1.8mm), clear piece of domestic glass (0.4g), possibly used as picture glass or similar. All the glass from this context dates from the later 19th or early 20th century.
- B.7.7 Trench 332 yielded a single neck shard of a probable aqua-coloured jar. This may be a domestic preserve-type jar and is likely to the 19th or early 20th century in date.

Recommendations for retention/disposal

- B.7.8 The glass recovered from the evaluation has been recorded in a spreadsheet. As the assemblage is of modern date it holds little potential to inform further work and can therefore be discarded.

B.8 Clay tobacco pipe

By John Cotter

Introduction and methodology

- B.8.1 Four pieces of clay pipe weighing 15g were recovered from three contexts. Given the small amount this has not been separately catalogued but is fully described below.
- B.8.2 For the London area, pipe bowls are assigned form codes based on Atkinson and Oswald's (1969) London pipes typology with bowl types assigned to an abbreviated code (e.g. AO22).

Description

- B.8.3 Context (22405) Spot-date: 19th century. Description: 2 pieces (weight 5g). 1x fresh slender 19th-century stem (length 51mm) with a plain slightly bevelled mouthpiece. 1x fresh slender stem of same date (49mm long).
- B.8.4 Context (23804) Spot-date: c 1850-1900. Description: 1 piece (weight 4g). Rim fragment from the front of a standard 19th-century spurred pipe bowl AO28 (Atkinson and Oswald 1969, 179). Traces of moulded decoration in high relief including the letters 'R A—' above part of a bull's or buffalo's head with a downturned horn. This is a common 19th-century design produced for the Royal and Ancient Order of Buffaloes. The design was particularly popular c 1850-1880 but continued in production beyond this date. Fairly fresh condition.
- B.8.5 Context (31207) Spot-date: Late 17th to early 18th century. Description: 1 piece (weight 6g). Early style 'chunky' stem fragment (length 53mm). Relatively narrow stem bore. Fairly abraded.

Recommendations for retention/disposal

- B.8.6 The pipes here have some potential for further study and should therefore be retained.

C.1 Environmental samples

By Richard Palmer

Introduction

C.1.1 Twenty-two flotation samples were taken as part of the evaluation on Lower Thames Crossing, Land South of Ockendon and Land South of North Ockendon, primarily for the retrieval and assessment of Charred Plant Remains (CPR) and the recovery of bones and artefacts.

C.1.2 Land Parcel 41 covers land in both Essex (LTC41N20) and the London Borough of Havering (LTC20) and has therefore been split into two sites for recording and possible archiving purposes but will be considered as one site for sample discussion. Based on this division, thirteen flotation samples are from Land South of Ockendon (LTC41N20), and nine flotation samples are from Land South of North Ockendon (LTC20).

Method

C.1.3 The samples were processed in their entirety at Oxford Archaeology using a modified Siraf-type water flotation machine. The flots were collected in a 250µm mesh and residues in a 500µm mesh and dried. The residue fractions were sorted by eye and with the aid of a magnet while the flot material was sorted using a low power (x10) binocular microscope to extract cereal grains and chaff, smaller seeds and other quantifiable remains.

Results: LTC20

C.1.4 Sample summary and flot abundance data for LTC20 is presented in Table 13 (LTC20).

C.1.5 **Trench 1.** Sample 4 from fill 105 of pit 104 produced a small root filled flot. A charred speedwell seed (*Veronica sp.*) was recovered along with goosefoot seeds (*Chenopodium sp.*) in an indeterminate state (Mueller-Bieniek *et al.* 2020) with a likelihood most are modern. Pottery was recovered from the residue.

C.1.6 Sample 5 from fill 109 of pit 108 produced a small flot with most recovered charcoal being extracted from the residue. A small fragment of charred hazelnut shell (*Corylus avellana*) was recovered with hazel also identified in the charcoal assemblage. Some charcoal fragments also appear highly vitrified. No artefacts were recovered from the residue.

C.1.7 **Trench 5.** Sample 6 from fill 503 of ditch 502 produced a small flot. The flot is rich in modern roots and the majority of the charred material has sandy surface concretions. This does not extend to the interior structure of the charcoal in most cases but did hinder identification of other material. Charcoal includes several small twig fragments and a mix of species including oak and cherry/blackthorn (*Prunus sp.*). Grain is a mix of possible wheat (cf *Triticum sp.*) and oat (cf *Avena sativa*). Charred legumes are also present, most in the 2mm size range but at least one is in the 4mm size range. Pottery and iron were recovered from the residue.

- C.1.8 Sample 7 from fill 506 of pit 504 produced a poor flot with some charcoal fragments. Pottery was recovered from the residue.
- C.1.9 **Trench 13.** Sample 8 from fill 1312 of pit 1310 produced a poor flot with a few charcoal fragments. No artefacts were recovered from the residue.
- C.1.10 Sample 9 from fill 1303 of ditch 1302 produced a very poor flot with a possible charred sedge seed (*Carex* sp.). No artefacts were recovered from the residue.
- C.1.11 **Trench 49.** Sample 3 from fill 4904 of ditch 4903 produced a small flot. A small hazelnut shell fragment (*Corylus avellana*) and an indeterminate grain were identified. Pottery and burnt flint were recovered from the residue.
- C.1.12 **Trench 68.** Sample 2 from layer 6803 produced a small flot. All charcoal is small-sized (<4mm in all planes) and the grain is possibly wheat (cf *Triticum* sp.). Fired clay and burnt flint were recovered from the residue.
- C.1.13 **Trench 72.** Sample 1 from fill 7203 of pit 7202 produced a small flot. A good quantity of charcoal is present, some of which is ring porous, but many fragments are small and/or thin in at least one plane reducing the number of potentially identifiable fragments. Fired clay was recovered from the residue.

Results: LTC41N20

- C.1.14 Sample summary and flot abundance data for LTC41N20 is presented in Table 14.
- C.1.15 **Trench 135.** Sample 3 from fill 13505 of pit 13503 produced a charcoal dominated flot. Other charred material is limited to an indeterminate weed seed. Burnt flint was recovered from the residue.
- C.1.16 Sample 4 from fill 13508 of pit 13507 produced a charcoal dominated flot. Burnt flint was recovered from the residue.
- C.1.17 **Trench 167.** Sample 5 from fill 16704 of posthole 16703 produced a small charcoal dominated flot, with most charcoal extracted from the residue. Charcoal preservation is poor but hazel (*Corylus*) is present. No artefacts were recovered.
- C.1.18 Sample 6 from fill 1706 of posthole 16705 produced a small charcoal rich flot. Ring porous type charcoal is present and field gromwell (*Lithospermum arvense*) was also identified. No artefacts were recovered.
- C.1.19 **Trench 168.** Sample 7 from fill 16804 of pit 16803 produced a small flot. The grain is in poor condition due to encrusting and damage but some is identified as wheat. Some of the damage could be attributed to spoilage of the grain from sprouting as some grains show possible collapse and at least one detached sprout was recovered. The weed assemblage includes charred grass seeds, dock (*Rumex* sp.) and charred seeds from stinking chamomile (*Anthemis cotula*) recovered as a cluster of five. Some oak and hazel was also identified in the charcoal. No artefacts were recovered.
- C.1.20 **Trench 240.** Sample 1 from fill 24006 of posthole 24005 produced a charcoal dominated flot. No finds were recovered from the residue.
- C.1.21 **Trench 246.** Sample 2 from fill 24606 of pit 24603 produced a charcoal dominated flot. Fired clay was recovered from the residue.

- C.1.22 **Trench 294.** Sample 9 from fill 29407 of pit 29405 produced a small flot. Most of the charcoal was recovered from the residue and a single wheat grain in poor condition is present in the flot. No artefacts were recovered.
- C.1.23 **Trench 304.** Sample 12 from fill 30404 of posthole 30403 produced a poor flot and no artefacts.
- C.1.24 **Trench 316.** Sample 11 from fill 31604 of ditch 31603 produced a poor flot. All the charcoal was recovered from the residue and the flot contains only a single charred glume fragment. No artefacts were recovered.
- C.1.25 **Trench 317.** Sample 10 from fill 31704 of pit 31703 produced a modest flot. Half of the recorded charcoal was recovered from the residue and the charcoal assemblage appears dominated by oak heartwood. No artefacts were recovered.
- C.1.26 **Trench 339.** Sample 13 from fill 33907 of ditch 33906 produced a poor flot consisting of sand, roots and rare modern plant material. All recorded charcoal was extracted from the residue which also produced some pottery.

Discussion

- C.1.27 Generally, there is potential for the recovery of charred material from features across the site although the quantities recovered from many samples is small. Charcoal from both areas is in poor to fair condition but many fragments are dirty or sand encrusted. This extends internally along with vitrification. Most samples have some potential for radiocarbon dating and whilst short lived species are present in some samples, in most cases confirmation of sample suitability would require further identification of the charcoal in order to identify whether short-lived taxa, sapwood or roundwood is present.
- C.1.28 At this stage spot dating is mainly available for some samples in the LTC20 area with most of those dated being medieval. One sample from LTC41N20 may be dated but at present the evidence is equivocal as finds come from two different periods. If material is to be selected for radiocarbon dating in the future, several samples from LTC41N20 include suitable short-lived material, but many samples include small numbers of identifiable charred plant remains and the possibility of residual or intrusive items would have to be considered.

Recommendations for retention/disposal

- C.1.29 The flots warrant retention until all works on site are complete but it is not expected that further work will be required at this time.

Sample	Context	Trench	Feature/deposit	Date	Sample vol. (L)	Flot vol. (ml)	Charcoal >2mm	Grain	Chaff	Weeds	Molluscs	Other	Notes
1	7203	72	7202	LBA-EIA	10	25	+++						7.5YR 5/4 and 5YR 4/6 sandy silt loam
2	6803	68	6803	C15th-16th	18	25	++	+					7.5YR 5/4 sandy silt loam

3	4904	49	4903	MED	20	25	++	+				+	10YR 4/3 sandy silt loam
4	105	1	104		33	12	++			++	+		Mid grey- brown sandy silt
5	109	1	108		16	10	+++					+	Mid grey brown sandy silt
6	503	5	502	MED	32	25	+++	++		+		+	Mid grey silty sand
7	506	5	504	MED	12	5	++						Mid grey brown sandy silt
8	1312	13	1310		16	22	++						Mid yellow brown sandy silt
9	1303	13	1302	MED	17	5				+			Mid grey brown sandy silt

Key: +=present (up to 5 items), ++=frequent (5-25), +++=common (25-100), ++++=abundant (100+)

Table 13: LTC20 - Assessment of CPR samples

Sample	Context	Trench	Feature/Deposit	Date	Sample vol. (L)	Flot vol. (ml)	Charcoal >2mm	Grain	Chaff	Weeds	Molluscs	Other	Notes
1	24006	240	24005		4	12	+++						10YR 5/4 and 10YR 5/2 sandy clay
2	24604	246	24603		16	50	++++				+		10 YR 5/2 and 10YR 6/5 sandy clay
3	13505	135	13503		20	50	++++			+			10YR 3/3 sandy loam
4	13508	135	13507		15	50	+++						10YR 4/4 sandy loam
5	16704	167	16703		4	10	++++						Mid grey brown sandy silt
6	16706	167	16705		4	20	+++		+	+			Mid grey brown sandy silt
7	16804	168	16803		14	14	+++	++		++			Mid grey brown sandy silt
9	29407	294	29405	Pre/Sax	36	10	+++	+					Dark greyish brown silty clay
10	31704	317	31703		37	35	++++						Mid greyish brown silty clay
11	31604	316	31603		32	25	+		+				Mid greyish/reddish brown silty clay
12	30404	304	30403		6	15	++						Dark greyish brown silty clay
13	33907	339	33906		33	40	++						Mid orangey brown silty clay

Key: +=present (up to 5 items), ++=frequent (5-25), +++=common (25-100), ++++=abundant (100+)

Table 14: LTC41N20 - Assessment of CPR samples

C.2 Animal bone

By Rebecca Nicholson

Introduction

C.2.1 The evaluation excavations at LTC20 and LTC41N20 recovered only a small amount of bone, amounting to 52 fragments in total (305g); none was recovered from the environmental samples. The bone was in moderate to poor condition, much of the surface is intact but the cortex is prone to flaking and the bone is brittle with much recent breakage. Phasing information is derived from ceramic spot-dates.

LTC20

C.2.2 Context 508: an undated pit fill, produced seven limb bones (166g) from what is likely to be a single individual, an adult sheep (Table 15). Measurements were taken following von den Driesch (1976) and the overall size of the bones suggests a post-medieval or modern date. The absence of carnivore gnawmarks suggests burial took place soon after death.

C.2.3 Context 4703: fill of ditch 4702 and dated as medieval, produced nine fragments (19g) of unworn cattle mandibular molar teeth.

LTC41N20

C.2.4 Context 29106: primary fill of ditch 29105 and dated as medieval, produced seventeen fragments of animal bone which are tiny, degraded and indeterminate (2g), the condition could be described essentially as “bone meal”.

C.2.5 Context 29406: Anglo-Saxon fill of pit 29405, produced three fragments of cattle molar, possibly from the same tooth but with no clear joins (3g).

C.2.6 Context 29407: prehistoric/Anglo-Saxon fill of pit 29405, produced fourteen fragments (112g). The identifiable specimens include one left side fragment of equid mandible comprising the condyle and coronoid process; a sheep/goat M3, in full wear and with surface damage to the dentine; a fragmentary left cattle mandible retaining an erupting and unworn M2; two left mandibular cattle teeth - a dp4 at wear stage j (Grant 1982) and a probable M1 at wear stage f, neither are likely to be from the mandible in this context.

C.2.7 Context 34304: late Roman fill of ditch 34303, produced two sheep/goat lower molars (5g) which are possibly part of the same tooththrow, the enamel and dentine in both was damaged by root etching.

Element	Side	Description
Radius	Right	Proximal end, fused
Ulna	Right	Proximal end, fused; SDO = 27.4mm, articulates with radius
Femur	Right	Lacks proximal third, distally fused
Tibia	Left	Complete, both ends fused, Bd = 30.5mm
Astragalus	Left	Complete, articulates with tibia, GLI = 33.0mm, GLm = 31.4mm, Bd = 21.9mm
Calcaneum	Left	Complete, articulates with astragalus, GI = 63.4mm
Tibia	Right	Proximal half, fused

Table 15: Sheep skeletal elements from context 508

Discussion

- C.2.8 The paucity of recovered bone and the prevalence of teeth in the identified specimens from the dated contexts – tooth enamel generally being more resistant to post-depositional destruction than bone - suggests that any future excavations in this area are unlikely to produce much bone from features earlier than the post-medieval. The recovery of oyster shell from contexts in Trench 235 and 238 (LTC41N20) indicates that some parts of the site may have feature fills where preservation of bone is possible but even here any animal remains are likely to be in poor condition and any fragments recovered are likely to be from larger mammals and more robust body parts.

Recommendations for retention/disposal

- C.2.9 The fragments have no research value and could be discarded.

C.3 Shell

by Rebecca Nicholson

Description

- C.3.1 Five fragments of oyster (*Ostrea edulis* L.) shell weighing 43g in total were recovered from two contexts: primary ditch fills 23514 and 23804. These contexts have been dated by associated ceramic finds as Roman and post-medieval respectively.
- C.3.2 The shell from 23514 comprises 3 body fragments probably from a single large and thick oyster left valve, in poor condition, which is heavily pockmarked with sponge boreholes and has a calcified worm tube encrustation. The shell from 23804 comprises one small right valve, in chalky condition but almost complete as well as a small fragment of oyster shell in similar, chalky, condition.

Recommendations for retention/disposal

- C.3.3 The fragments have no research value and could be discarded.

Appendix D References

- ACBMG, 2007 Ceramic building material, minimum standards for recovery, curation, analysis and publication
- Atkinson, D and Oswald, A, 1969 London clay tobacco pipes. *Journal of the British Archaeological Association*, Third Series, **32**, 171-227
- Bamford, H, 1985 *Briar Hill: excavation 1974-1978*, Northampton: Northampton Development Corporation. Archaeological monograph **3**
- Bennett, A, 2011 The historic landscape characterisation report for Essex. Essex County Council and English Heritage
- Biddulph, E, and Brady, K, 2015 *Excavations along the M25: Prehistoric, Roman and Anglo-Saxon activity between Aveley and Epping, Essex*, Essex Society for Archaeology and History Occasional Papers, New Series, **3**
- Biddulph, E, Compton, J and Martin, T S, 2015 The late Iron Age and Roman pottery, in M. Atkinson and S. J. Preston, Heybridge: A late Iron Age and Roman settlement: Excavations at Elms Farm 1993-5, *Internet Archaeology* **40**, [REDACTED]
- Birbeck, V and Barnes, I, 1994 *Horndon to Barking Natural Gas Transmission Pipeline. Archaeological Investigation 1993*. Wessex Archaeology
- BGS, 2020 *Geology of Britain Viewer*. Retrieved from [REDACTED]
- Brudenell, M, 2016a, Late Bronze Age pottery, in C Evans, G Appleby, and S Lucy, with Appleby, J and Brudenell, M, 2016 *Lives in the Land. Mucking Excavations by Margret and Tom Jones, 1965-1978: Prehistoric, Context and Summary*, Oxbow Books, 158-88
- Brudenell, M, 2016b, Middle Iron Age pottery, in C Evans, G Appleby, and S Lucy, with Appleby, J and Brudenell, M, 2016 *Lives in the Land. Mucking Excavations by Margret and Tom Jones, 1965-1978: Prehistoric, Context and Summary*, Oxbow Books, 365-93
- Butler, C, 2005 *Prehistoric Flintwork*. Tempus
- CIfA, 2014a *Standard and guidance for archaeological evaluation*. Chartered Institute for Archaeologists
- CIfA, 2014b *Standard and guidance for the creation, compilation, transfer and deposition of archaeological archives*. Chartered Institute for Archaeologists
- Cotter, J P, 2000 *Post-Roman Pottery from Excavations in Colchester 1971-1985*, Colchester Archaeological Report **7**
- Evans, C, Appleby, G, and Lucy, S, 2016 *Lives in Land: Mucking Excavations by Margaret and Tom Jones, 1965-1978. Prehistory: context and summary*,

Cambridge Archaeological Unit Archives Series: Historiography and Fieldwork 2/Mucking 6.

Ford, B, Harris, J and Poole, C, 2014 The Home Park Road: Hampton Court Palace. Archaeological evaluation report, Oxford Archaeology, unpublished client report

Ford, D, 1991 *Hampton Court Palace brick typology*, English Heritage

Harrison, E, 2000 Pottery and Fired Clay, in E Guttmann and J Last, A Late Bronze Age Landscape at South Hornchurch, Essex, *Proceedings of the Prehistoric Society* **66**, 337-44

Healy, F, 1988 *The Anglo-Saxon cemetery at Spong Hill, North Elmham, Part VI: Occupation during the seventh to second millennia BC*, East Anglian Archaeological report **38**

Heppell, E, 2010 The Greater Thames Estuary. Historic environment research framework 2010, part 2: strategy tables, [REDACTED]

Highways England, 2018 Lower Thames Crossing: A scheme wide specification for archaeological trial trenching: unpublished document HE540039-CJV-GEN-GEN-SPE-HER-00001draft, Revision 1.05

Historic England, 2015 *Management of Research Projects in the Historic Environment: The MoRPHE Project Managers' Guide*. Centre for Archaeology guidelines

Howell, I J, Swift, D and Watson, B, with Cotton, J and Greenwood, P, 2011 *Archaeological landscapes of east London: Six multi-period sites excavated in advance of gravel quarrying in the London Borough of Havering*, Museum of London Archaeology monograph **54**

Inizan, M-L, Reduron-Ballinger, M, Roche, H and Tixier, J, 1999 *Technology and terminology of knapped stone*, Cercle de Recherches et d'Etudes Préhistoriques, CNRS

Medlycott, M (ed.), 2011 *Research and archaeology revisited: A revised framework for the East of England*. East Anglian Archaeology Occasional Paper **24**

MoLA, 2011 *Archaeological landscapes of east London: Six Multi-period sites excavated in advance of gravel quarrying in the London Borough of Havering*, London: Museum of London Archaeology.

MOLA, 2014a Roman pottery codes, [REDACTED]

MOLA, 2014b London medieval and post-medieval pottery codes, Museum of London Archaeology, [REDACTED]

- MOLA, 2014c Medieval and post-medieval ceramic building materials fabric dating codes, [REDACTED]
[REDACTED]
- OA, 2019a Lower Thames Crossing scheme-wide written scheme of investigation for trial trenching south of the River Thames, Oxford Archaeology report
- OA, 2019b Lower Thames Crossing scheme-wide written scheme of investigation for trial trenching north of the River Thames, Oxford Archaeology report
- OA 2019c Lower Thames Crossing detailed written scheme of investigation for trial trenching of Land Parcels 41-42, 44 & 60, Oxford Archaeology report
- Palmer, J J N, 2019 Open Domesday, [REDACTED]
- PCRG, SGRP, MPRG, 2016 *A standard for pottery studies in archaeology*, Prehistoric Ceramics Research Group, Study Group for Roman Pottery, and the Medieval Pottery Research Group
- Place Services, 2019 Lower Thames Crossing aerial investigation and mapping report
- Simmonds, A, Cook, S, Biddulph, E and Score, D, 2009 *Archaeology in the Park: Excavations at Jennett's Park, Bracknell, Berkshire*, Oxford Archaeology Occasional Paper **18**
- Smith, T P, 2001 On 'small yellow bricks ... from Holland', *Construction History* **17**, 31-42
- Stocks-Morgan, H, 2017a Multi-period remains from Zone E, Beaulieu, Chelmsford, Essex: Post-excavation assessment and updated project design, Oxford Archaeology
- Stocks-Morgan, H, 2017b Transitional medieval brick kilns at Site 3, Beaulieu, Chelmsford, Essex: Post-excavation assessment and updated project design, Oxford Archaeology
- Tomber, R and Dore, J, 1998 *The National Roman fabric reference collection: a handbook*, MoLAS Monograph **2**
- Thompson, I, 1982 *Grog-tempered 'Belgic' pottery of south-eastern England*, BAR Brit. Ser. **108**
- VCH, 1978 Parishes: North Ockendon, in *A history of the county of Essex, volume 7* (ed. W. R. Powell), Victoria County History. British History Online
[REDACTED]
- Wilkinson, T J, 1988 *Archaeology and environment in South Essex*. East Anglian Archaeology Report **42**

Appendix E Abbreviations and Glossary

ADS Archaeology Data Service. Digital archaeological archive

CDM Construction Design Manual. Health and safety guidance for the construction industry

CPD Continuing Professional Development

CIfA Chartered Institute for Archaeologists

DBA Desk Based Assessment. Detailed assessment of archaeology and other aspects of the historic environment

DCO Development Consent Order

EIA Environmental Impact Assessment. Detailed study of environmental impacts as directed under the The Town and Country Planning (Environmental Impact Assessment) Regulations 2017 following on from EU Directive EIA Directive (85/337/EEC)

ES Environmental Statement. The principal environmental report detailing environmental impacts within an EIA

GPS Global Positioning System

HER Historic Environment Record

LTC Lower Thames Crossing

MCIfA Member of the Chartered Institute for Archaeologists

MoRPHE Management of Research Projects in the Historic Environment

NMP National Mapping Programme. A study of aerial photographs and digitisation of resulting data into GIS. Originally funded by Historic England

NHLE National Heritage List for England. Includes listed buildings and scheduled monuments

OASIS Online Access to the Index of archaeological investigations.
The OASIS project brings together a number of strategic partners: the Archaeology Data Service, Historic England, Historic Environment Scotland, and the Royal Commission on the Ancient and Historical Monuments of Wales under the umbrella of the University of York

OCN Old County Number. Historic England’s reference for material that is not readily-available online and may represent historic archaeological work that consists of paper archives or has yet to be formally reported on

PINS Planning Inspectorate

RAMS Risk Assessment Method Statement

SMC Scheduled monument consent

TDR Trusted Digital Repository

UKIC United Kingdom Institute for Conservation

WSI Written Project of Investigation. A detailed method statement for archaeological work

WSL – Western Southern Link
The Western Southern Link (WSL) is an alternative for Short List Routes 2, 3 and 4 to the south of the River Thames.

Appendix F Site Summary

Site name:	Lower Thames Crossing Land Parcels 41, 42, 44 and 60, Land South of Ockendon, in Thurrock, Essex, and the London Borough of Havering
Site code:	LTC20 and LTC41N20
Grid Reference	NGR 559121 183872
Type:	Evaluation
Date and duration:	16th September 2020 to 28th October 2020 and 25th May to 2nd July 2021
Area of Site	59.78ha

Location of archive:

The archive from LTC20 and LTC41N20 (Land Parcels 41, 42, 44 and 60) will form part of the overall trial trenching scheme archive. This will be deposited in a repository consistent with the standards required by the Museums and Galleries Commission following completion of the archaeological phase of this project. This may either be with the local receiving museum in Thurrock or the Museum of London according to the relevant collecting areas covered by the site. If no such repositories are available, with a repository for the whole project designated by LTC. LTC retain the overall responsibility for the successful deposition of the project archive.

Currently, the archive is held at Oxford Archaeology's head office, Janus House, Osney Mead, Oxford, Oxfordshire, OX2 0ES. Oxford Archaeology will store the archive for LTC for a maximum period of 2 years following the completion of the project. If the storage of the archive at OA's office extends past this period, an extension to the storage period and final deposition timetable will be reviewed by OA and LTC and agreed with the major stakeholders.

Summary of Results:

Oxford Cotswold Archaeology was commissioned by Balfour Beatty to undertake a trial-trench evaluation of Land Parcels 41, 42, 44 and 60 covered by WSI F of the Lower Thames Crossing Pre-Enabling Works. The northern part of Parcel 41 is located in the historic parish of North Ockendon in the London Borough of Havering. Parcels 42, 44 and 60, and the southern part of Land Parcel 41, are in the historic parish of South Ockendon in Thurrock unitary authority within the county of Essex (NGR 559121, 183872). A total of 346 trenches representing a 4% sample of the accessible areas were excavated and recorded between 16th September and 28th October 2020 and between 25th May June and 2nd of July 2021.

The trenches revealed only sparse artefactual evidence for earlier prehistoric activity in the form of scattered struck flints of later Mesolithic or early Neolithic date and a single sherd possibly of Beaker or early Bronze Age date. Two large penannular cropmark enclosures potentially of earlier prehistoric date were targeted, and both revealed corresponding soilmarks; one was shallow and there were no finds, while the other was only minimally sampled as it was judged to be of natural origin.

Later Bronze Age or Iron Age activity was more prevalent, pottery of these periods being found both in pits and ditches, including a possible small rectilinear enclosure in the north-west part of the site, but some of the pottery was residual in later features. Further south, a group of ditches running ENE and containing later prehistoric pottery corresponded to a cropmark ditch, and probably relate to cropmark trackways or droeways and an enclosure outside the site to the west. The cropmarks of a ring ditch 15m across and a semi-circular larger enclosure may also be related, although the only dating evidence from them was a single struck flint. A few features contained definitely Iron Age pottery, including one example of an early Iron Age expanded rim.

Late Iron Age or early Roman pottery was found in ditches in several trenches in the north-west of the site, possibly peripheral to a focus beyond the site. In Land Parcel 60 west of the B186 a cluster of discrete cropmarks thought to represent pits, a ring ditch 10m in diameter and an arc of gully were targeted, but although the cropmark ring ditch was encountered and excavated, this did not contain dating evidence, and neither the arc of gully nor the discrete cropmarks that lay within the trenches proved to be genuine features. While the ring ditch may be later prehistoric, several arcs of curvilinear

gully indicating enclosures of similar size were revealed in adjacent trenches, one of which contained a sherd of Roman pottery, and two ditches in neighbouring trenches possibly belonging to one system also contained Roman pottery, perhaps indicating a focus of early-middle Roman activity here. The paucity of finds suggests that this was not domestic in character. Later Roman activity was evident from a few sherds in the south-eastern part of the site, but otherwise Roman finds were sparse.

Evidence for Saxon activity was restricted to the east end of the site. A ditch in the north-east corner contained six sherds of Anglo-Saxon pottery, and another ditch in the far south-east of Land Parcel 44 produced another two sherds. Medieval activity was found in two main areas. In the northern part of Land Parcel 41, pottery recovered from field boundaries was dated to the late Saxon or Norman period. Clearer evidence of domestic activity here is evident in the 13th-14th centuries, with ditches and pits in several trenches along the north edge of the site that contained sizeable assemblages of domestic pottery and environmental remains including charcoal, cereals and weed seeds. Although no structural evidence was seen, this activity is likely to be very close to a focus of settlement of this date, probably the medieval manor and surrounding settlement of North Ockendon. In the south-east corner of Land Parcel 60, to the west of the B186, 13th/14th-century ditches may indicate a rectilinear enclosure.

At the western edge of Land Parcel 41, near to North Ockenden, two trenches revealed evidence for industrial activity dating to the 15th or 16th century. The precise nature of the industry is unclear, although the remains and field-name evidence indicates brick production from this period, with a possible brick clamp or kiln debris being recorded. Brick production at this location may have contributed to the construction of North Ockendon Hall.

In the post-medieval period, the site appears to have been used mainly for agriculture, with numerous boundary ditches and drainage features installed across the fields. Occasional ponds may have originated as localised quarries, or may indicate that part of the site was used as pasture.

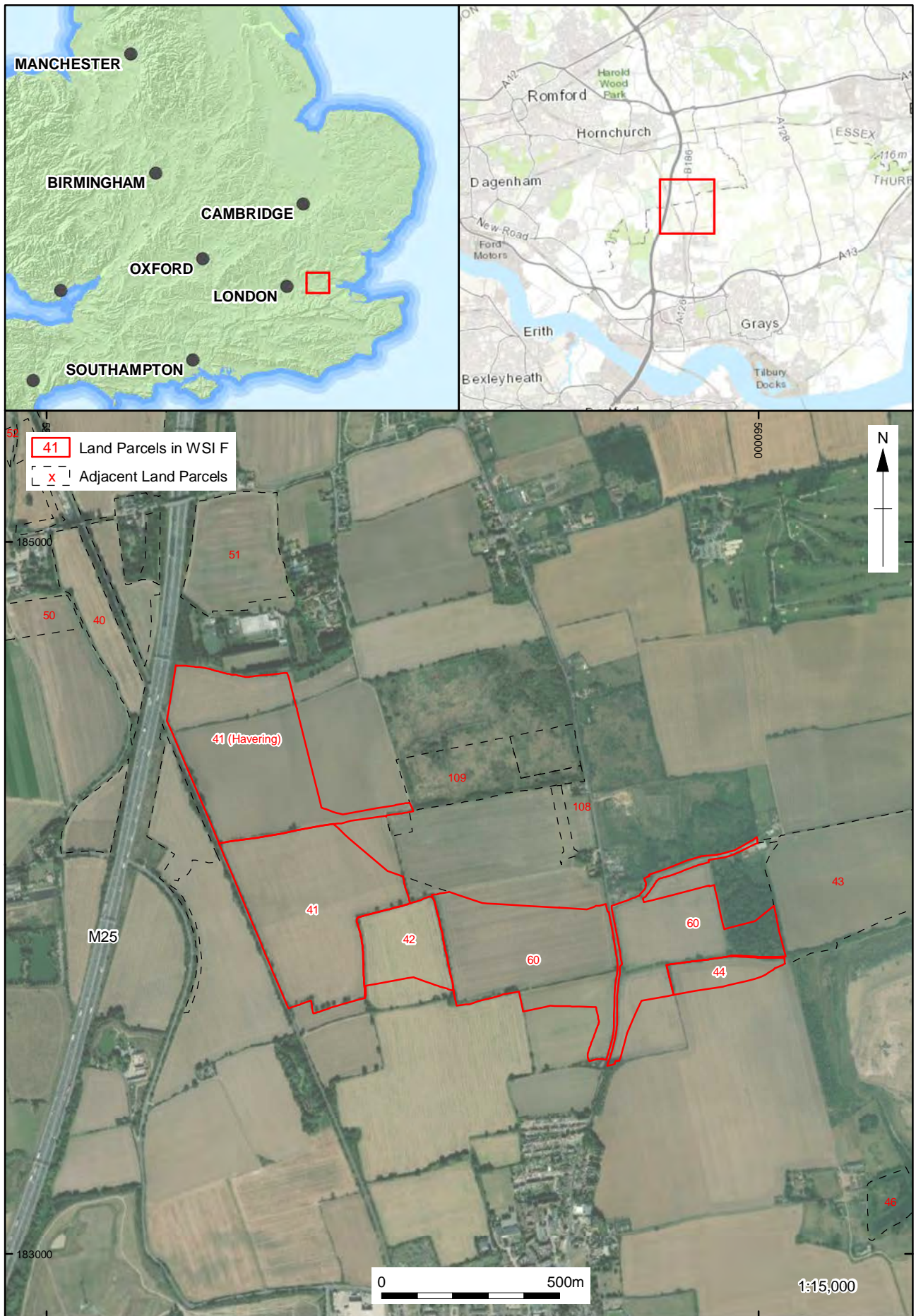

X:\MLTCEV_Lower_Thames_Crossing\010Geomatics\03 GIS Projects - LTC41N20\LTC Reports\LTC_Report_Fig1.mxd\aidan.farman\06/01/2021

Source: Esri, Maxar, GeoEye, Earthstar Geographics, CNES/Airbus DS, USDA, USGS, AeroGRID, IGN, and the GIS User Community
 Contains Ordnance Survey data © Crown copyright and database right 2016

Figure 1: Site location

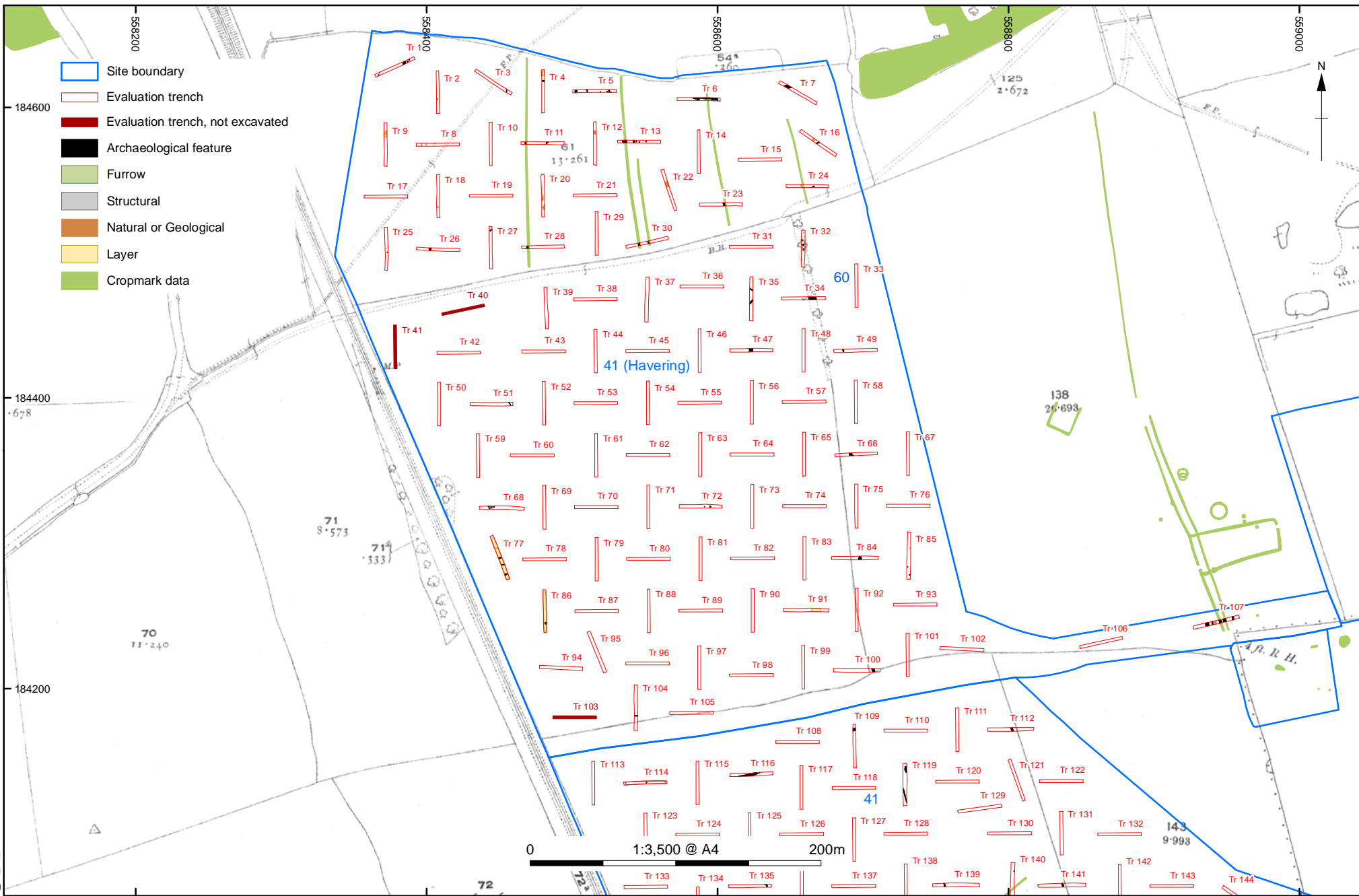

Contains Ordnance Survey data © Crown copyright and database right 2020, provided by client

Figure 2: Trenches 1-107, Land Parcel 41, Havering (LTC20): Trench layout showing cropmark features and archaeological features (overlying 1896 OS map)

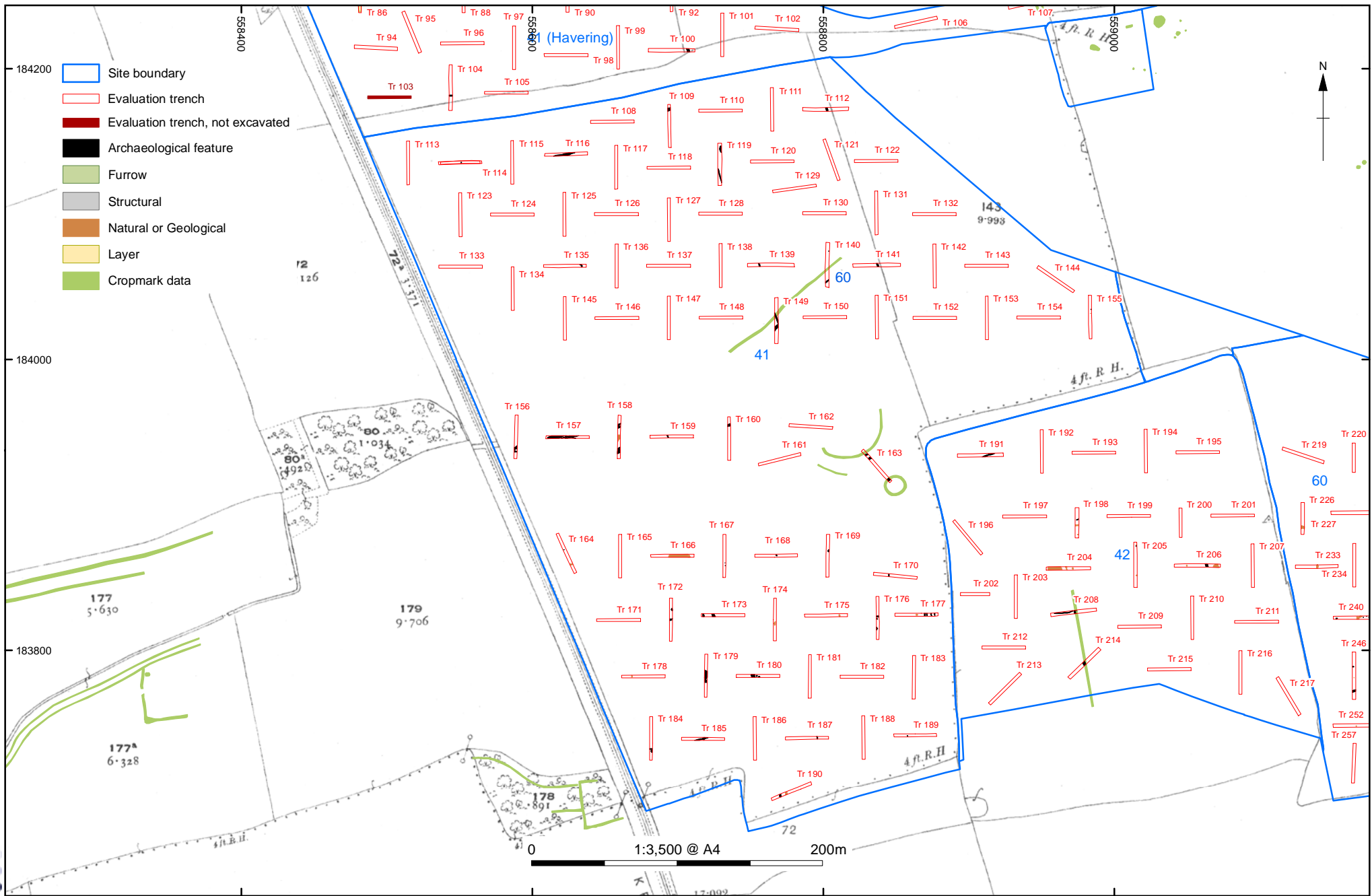

Contains Ordnance Survey data © Crown copyright and database right 2020, provided by client

Figure 3: Trenches 108-217, Land Parcels 41 and 42, Essex (LTC41N20): Trench layout showing cropmark features and archaeological features (overlying 1896 OS map)

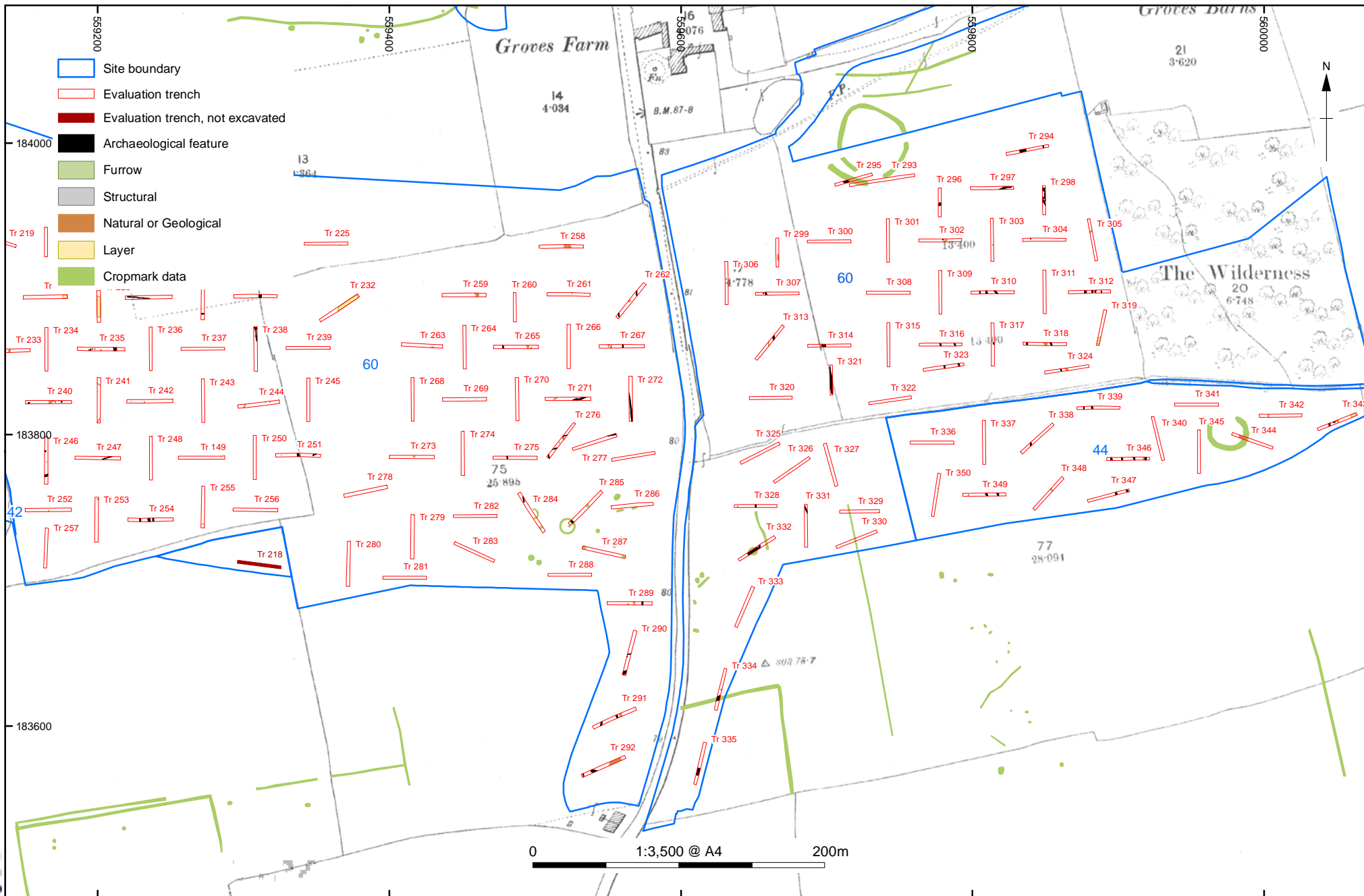

Contains Ordnance Survey data © Crown copyright and database right 2020, provided by client

Figure 4: Trenches 219-292, Land Parcels 60 and 44, Essex (LTC41N20): Trench layout showing cropmark features and archaeological features (overlying 1896 OS map)

X:\ILTCEV_Lower_Thames_Crossing\010Geomatics\03 GIS Projects - LTC41N20\Figures\LTC_Report_FigureA.mxd*aldan*02/09/2021

- Site boundary
- Evaluation trench
- Trench bottom
- Section line
- Intervention
- Feature
- Truncation
- Deposit
- Natural

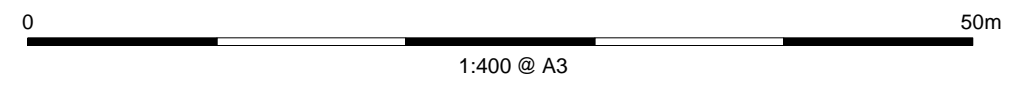
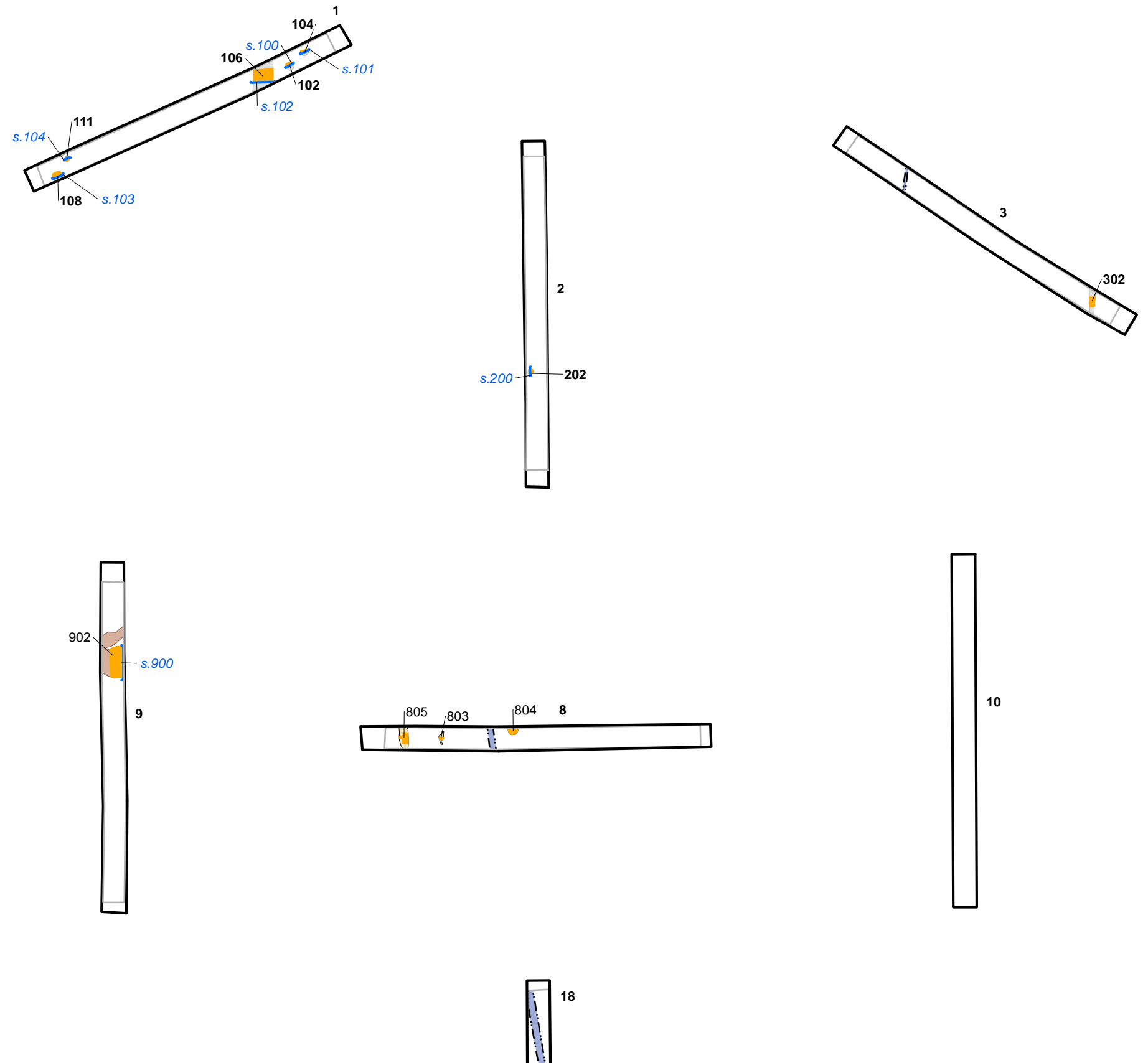

Figure 6: Plan of Trenches 1-3 and 8-9

X:\ILTCEV_Lower_Thames_Crossing\010Geomatics\03 GIS Projects - LTC41N20\Figures\LTC_Report_FigureB.mxd*aldan*02/09/2021

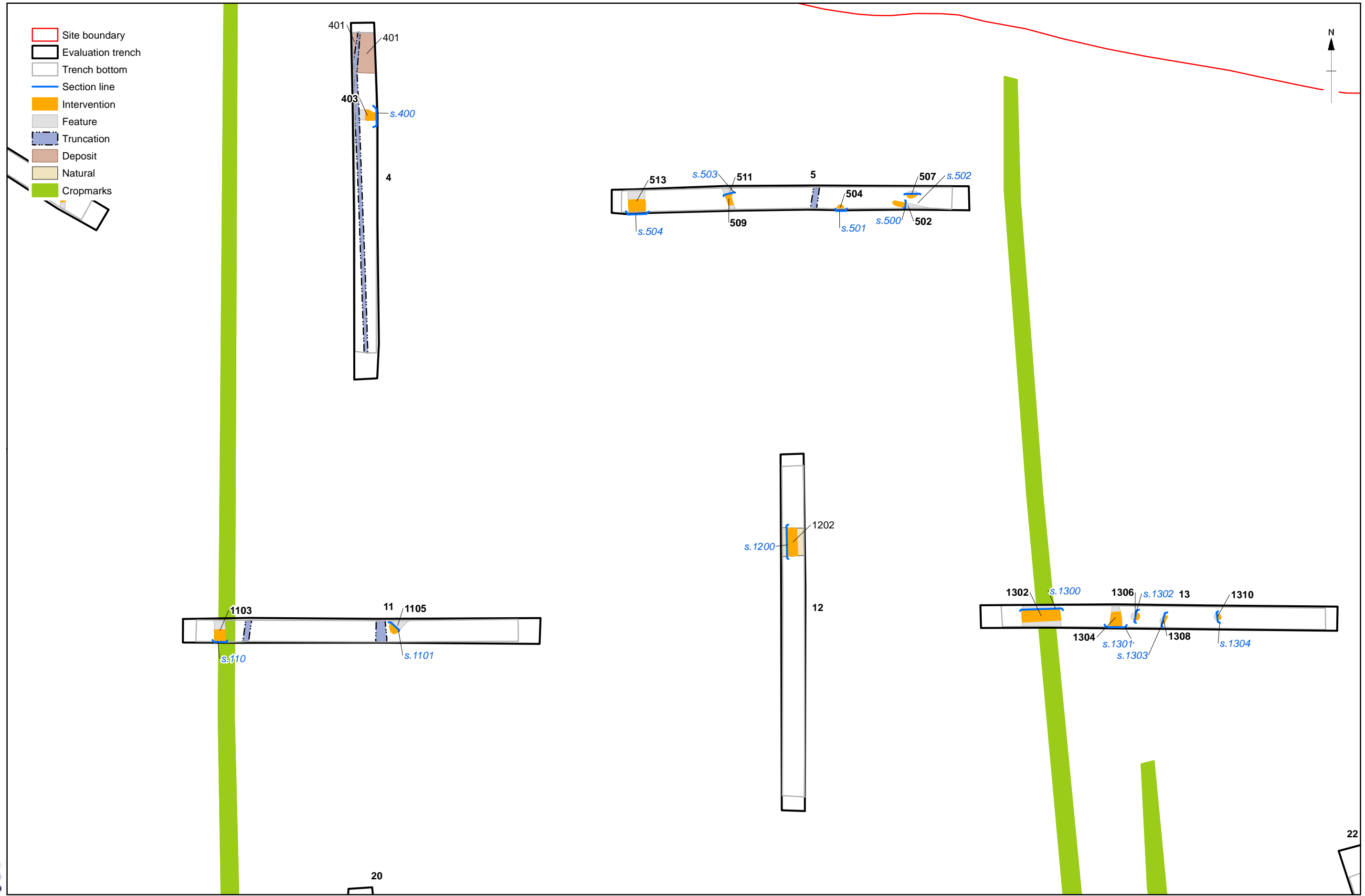

Figure 7: Plan of Trenches 4-5 and 11-13

X:\ILT\TCEV_Lower_Thames_Crossing\010\Geomatics\03 GIS Projects - LTC41N20\Figures\LTC_Report_FigureD.mxd*aidan.farman 27/08/2021

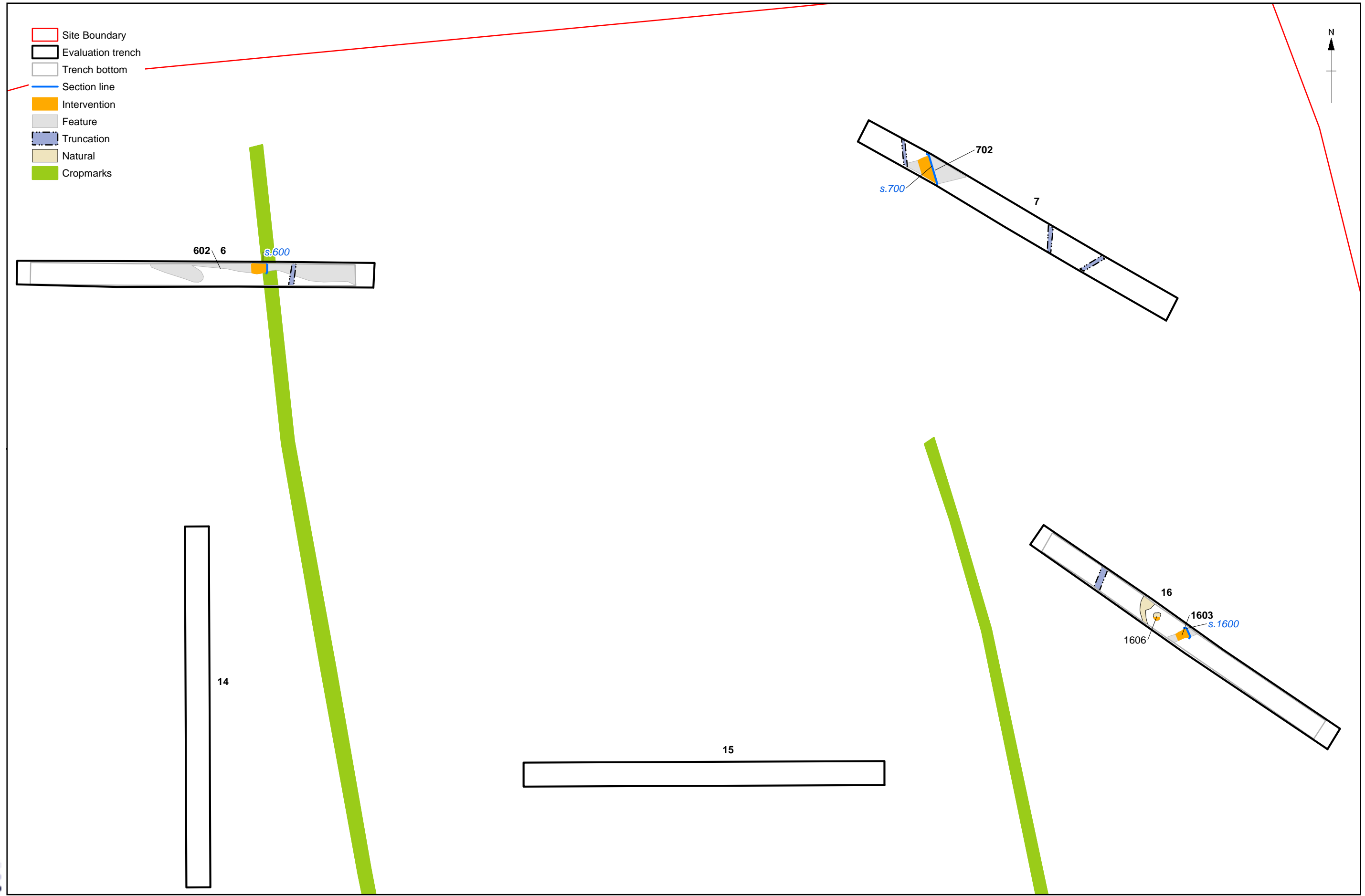
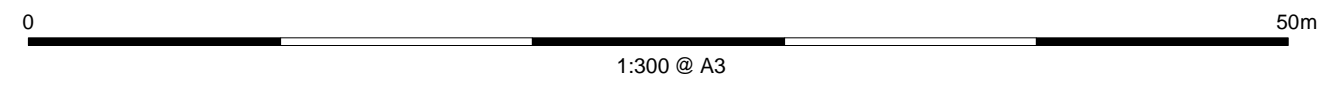

Figure 8: Trenches 6, 7 and 16



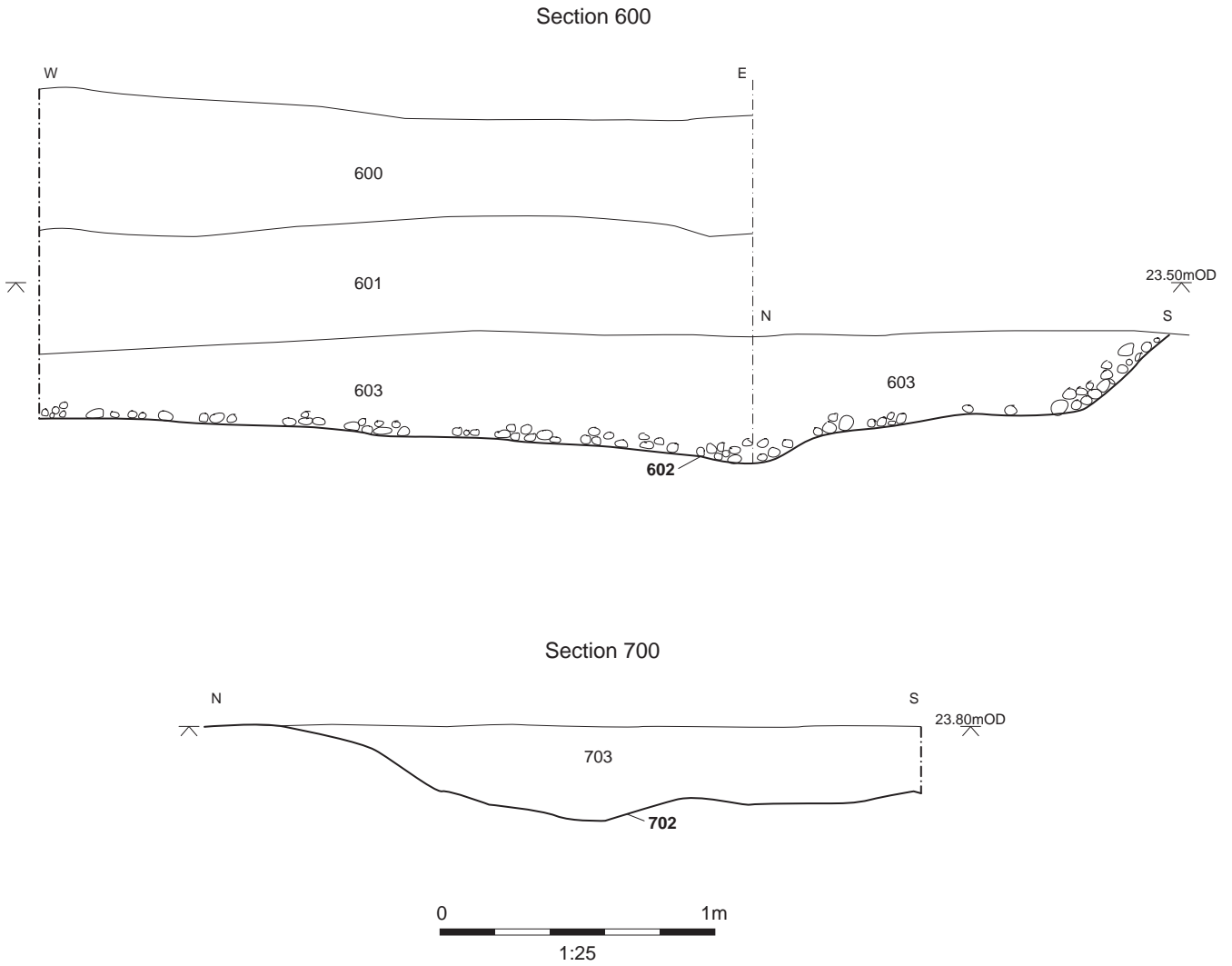
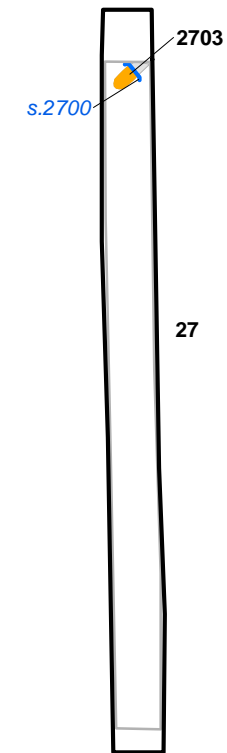
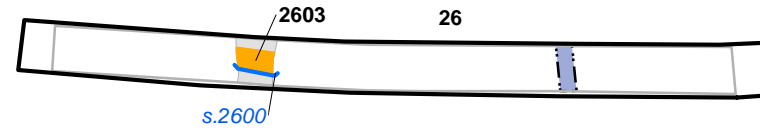
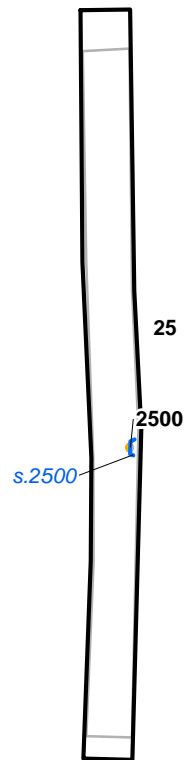
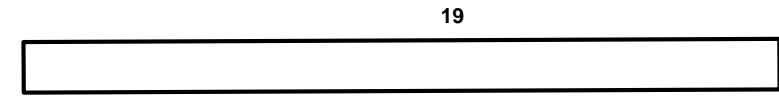
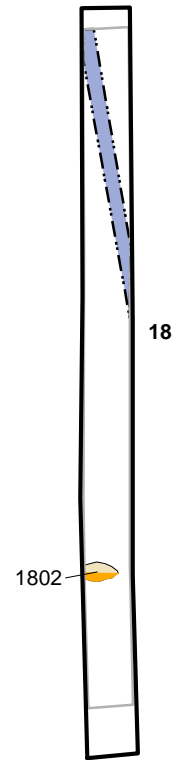
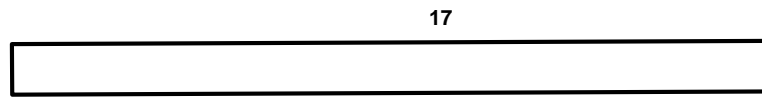

Figure 9: Sections (Trenches 6 and 7)

- Site Boundary
- Evaluation trench
- Trench bottom
- Section line
- Intervention
- Feature
- Truncation
- Natural



1:300 @ A3

Figure 10: Plan of Trenches 18 and 25-27

X:\ILTCEV_Lower_Thames_Crossing\010Geomatics\03 GIS Projects - LTC41N20\Figures\LTC_Report_FigureF.mxd\aldan.farman\27/08/2021

- Site Boundary
- Evaluation trench
- Trench bottom
- Section line
- Intervention
- Feature
- Truncation
- Natural
- Cropmarks

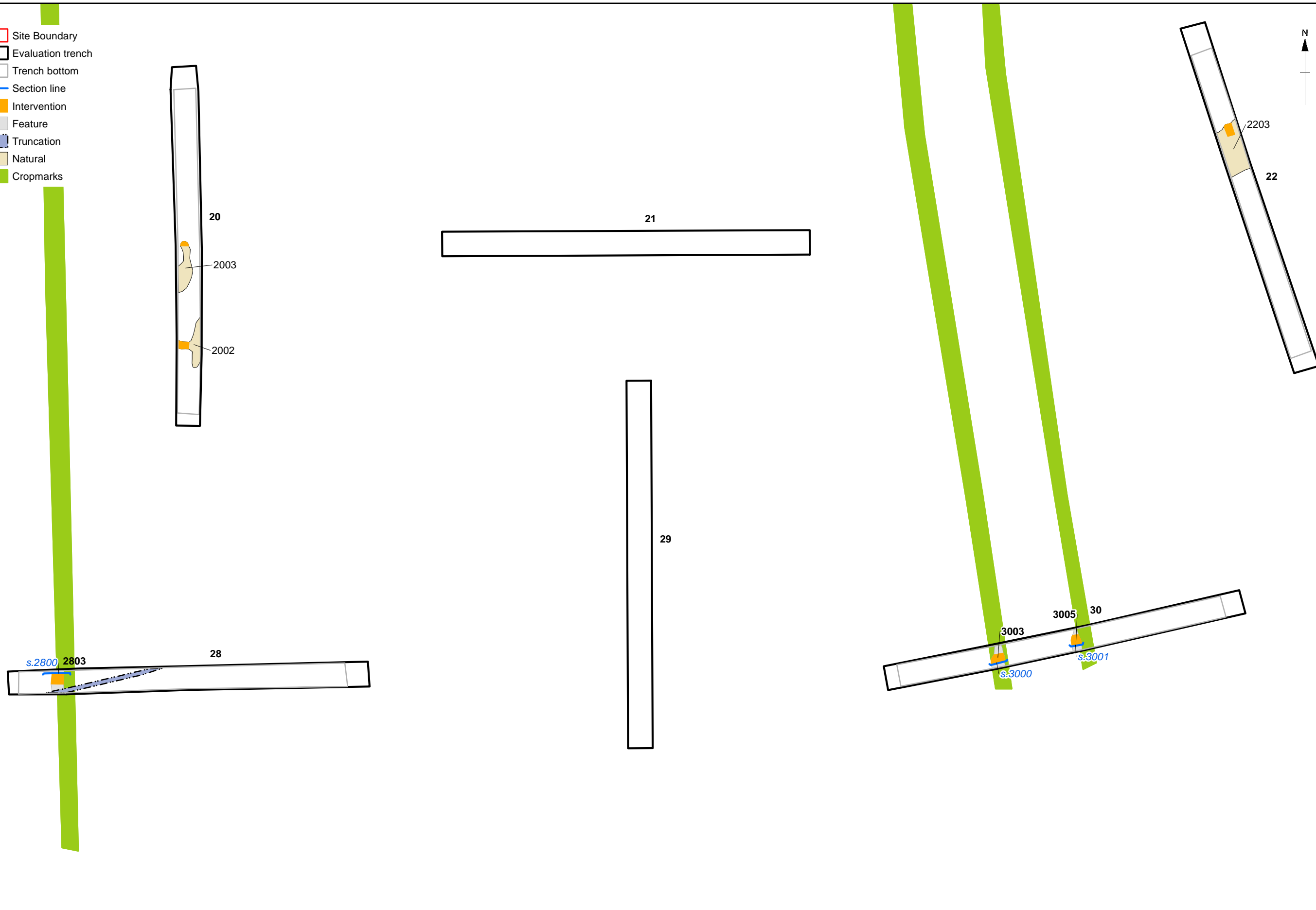

Figure 11: Plan of Trenches 20, 22, 28 and 30

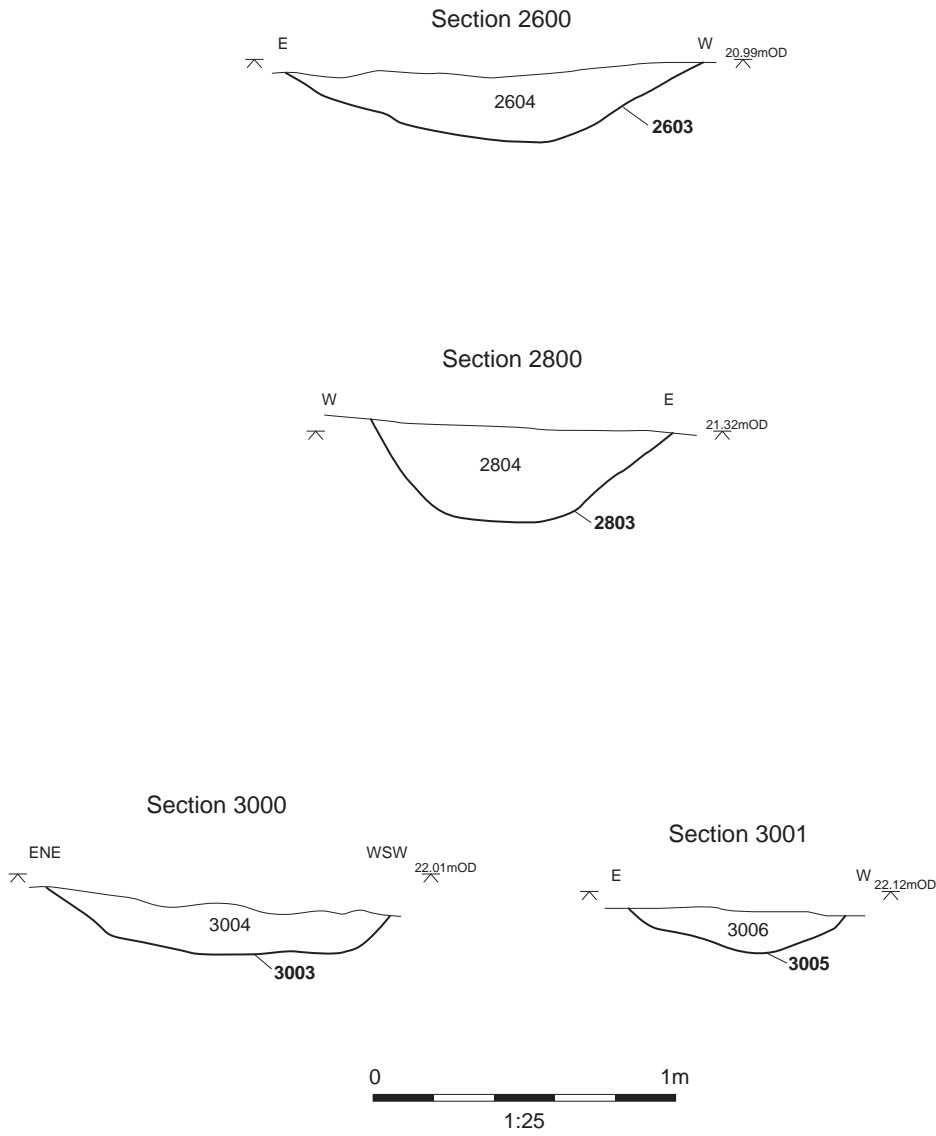

Figure 12: Sections (Trenches 26, 28 and 30)

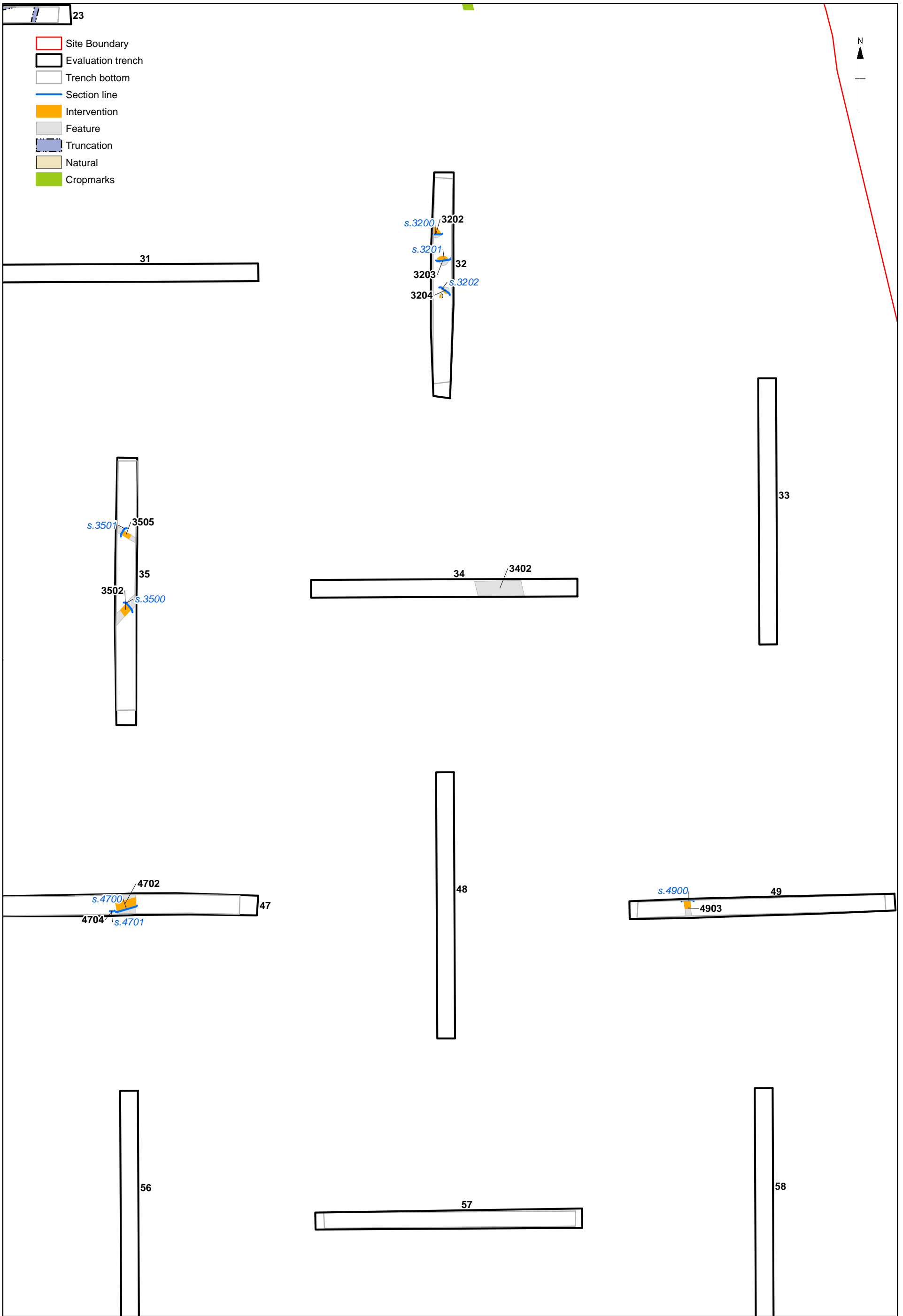
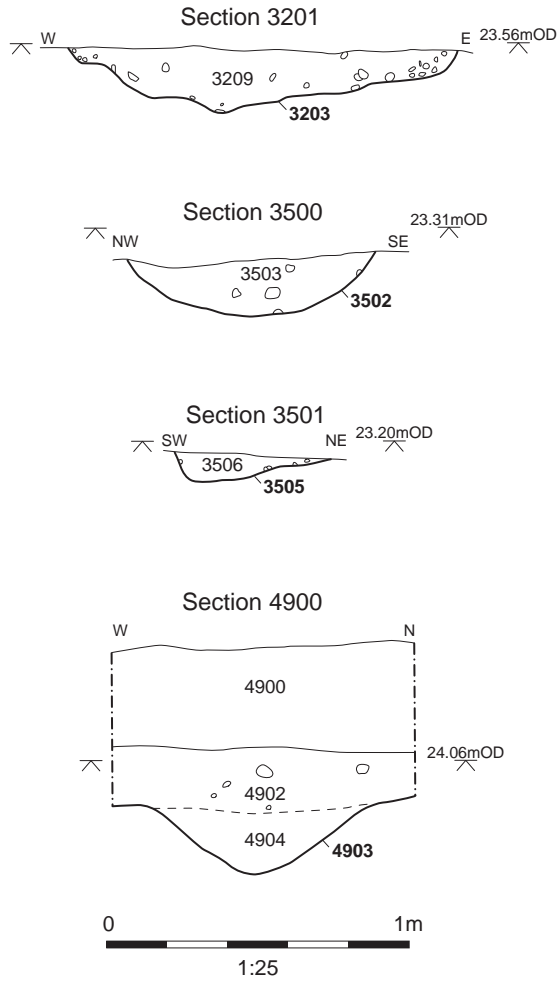

Figure 13: Plan of Trenches 32, 35, 47 and 49

0 50m
1:400 @ A3

X:\ILTCEV_Lower_Thames_Crossing\010\Geomatics\03 GIS Projects - LTC41N20\Figures\LTC_Report_Figure13.mxd\aidan.farnan\03/09/2021



^

Figure 14: Sections (Trenches 32, 35 and 49)

X:\ILTCEV_Lower_Thames_Crossing\010Geomatics\03 GIS Projects - LT\CA1N20\TC Reports\LT_Report_TrenchPlans_DD_A3.a.mxd*benjamin.brown*26/10/2021

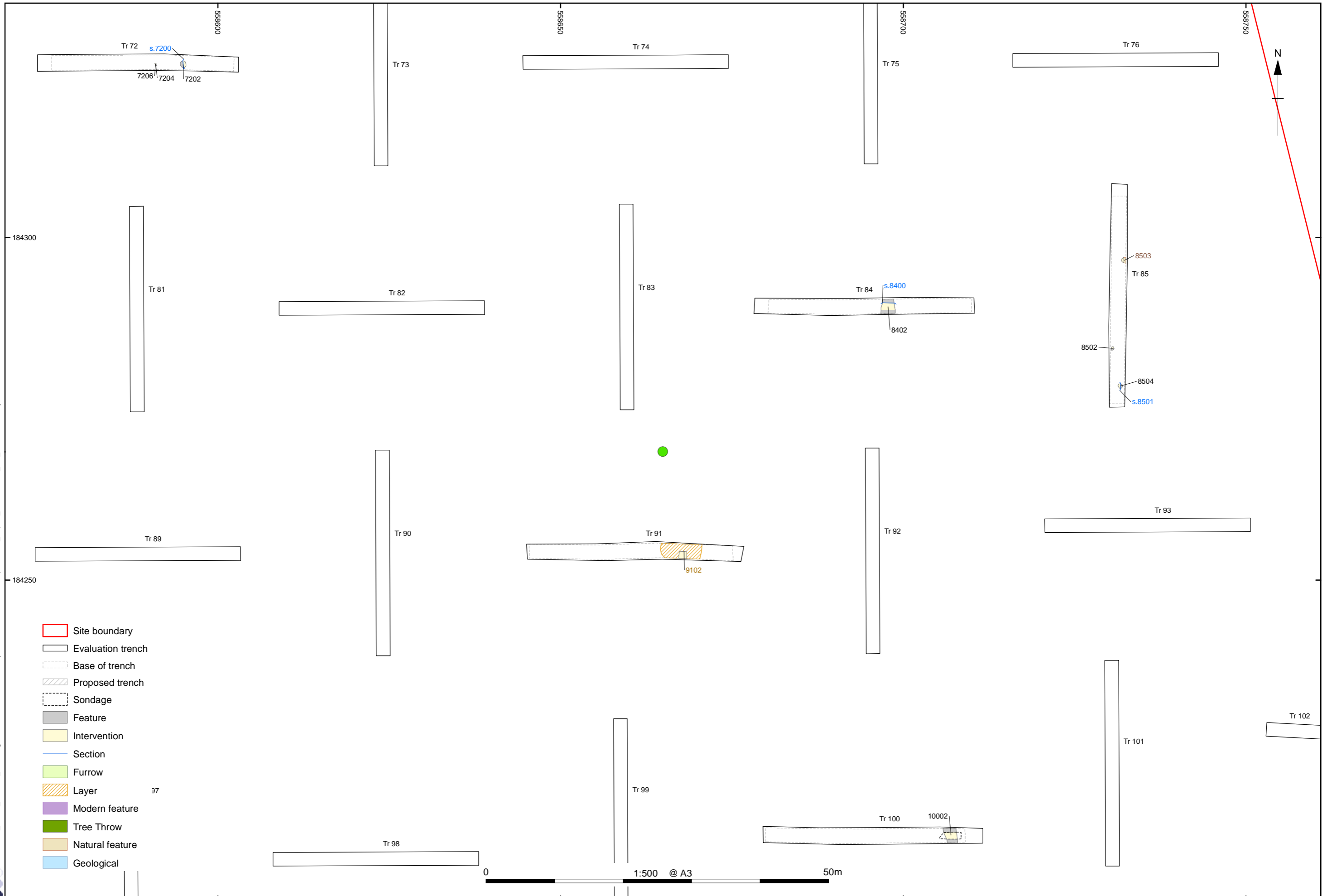

Contains Ordnance Survey data © Crown copyright and database right 2021

Figure 15: Plan of Trenches 72, 84, 85 and 100

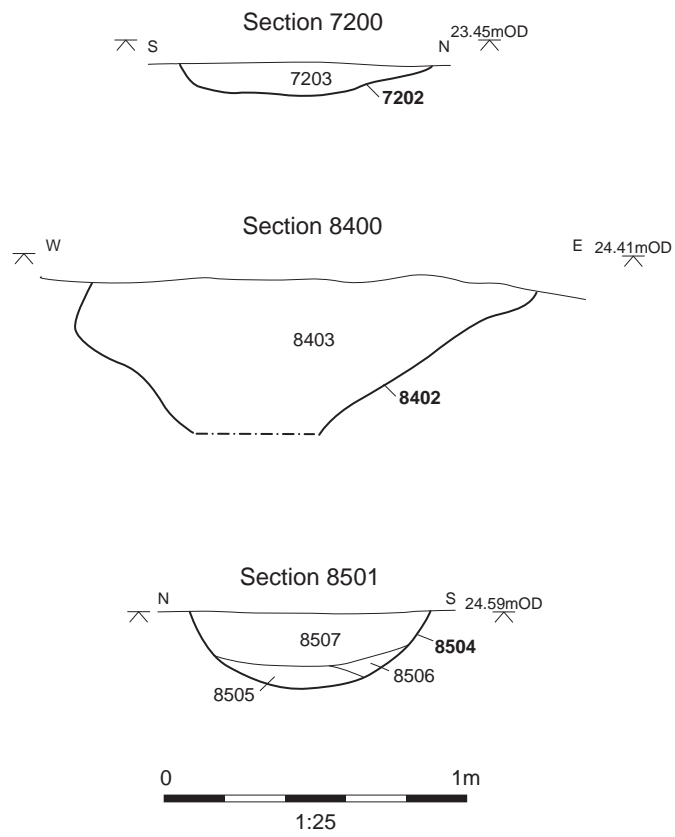
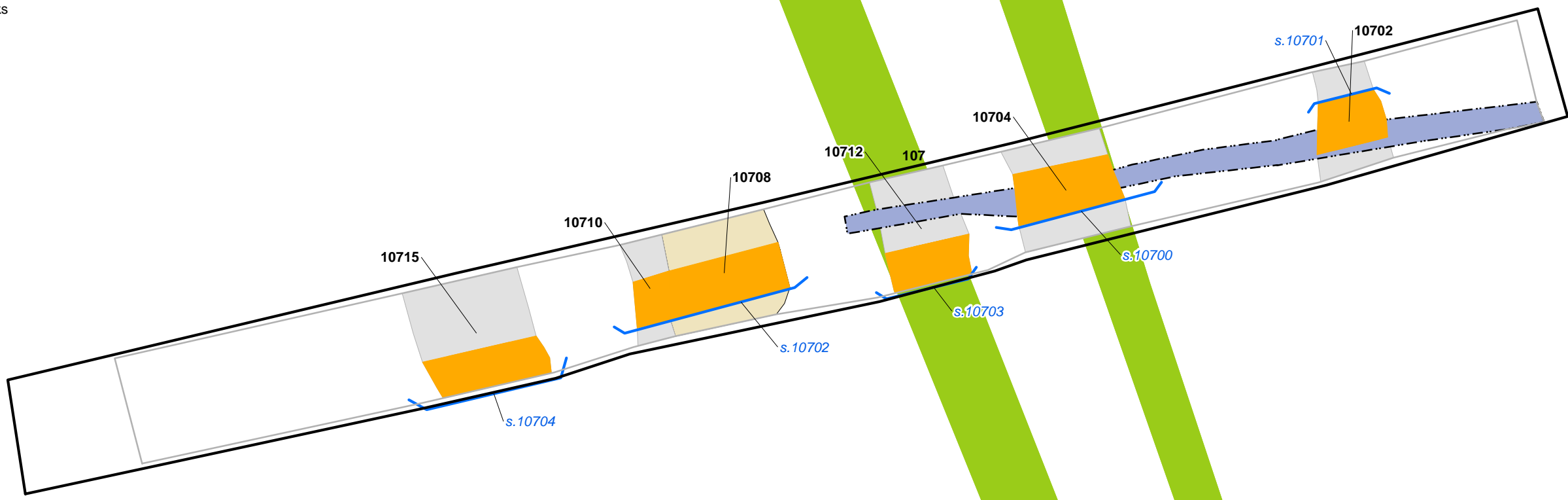

Figure 16: Sections (Trenches 72, 84 and 85)

- Site Boundary
- Evaluation trench
- Trench bottom
- Section line
- Intervention
- Feature
- Truncation
- Natural
- Cropmarks



X:\ILTCEV_Lower_Thames_Crossing\010Geomatics\03 GIS Projects - LTC41N20\Figures\LTC_Report_Figure17.mxd\aldan.farman\06/09/2021

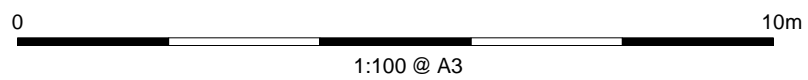

Figure 17: Plan of Trench 107

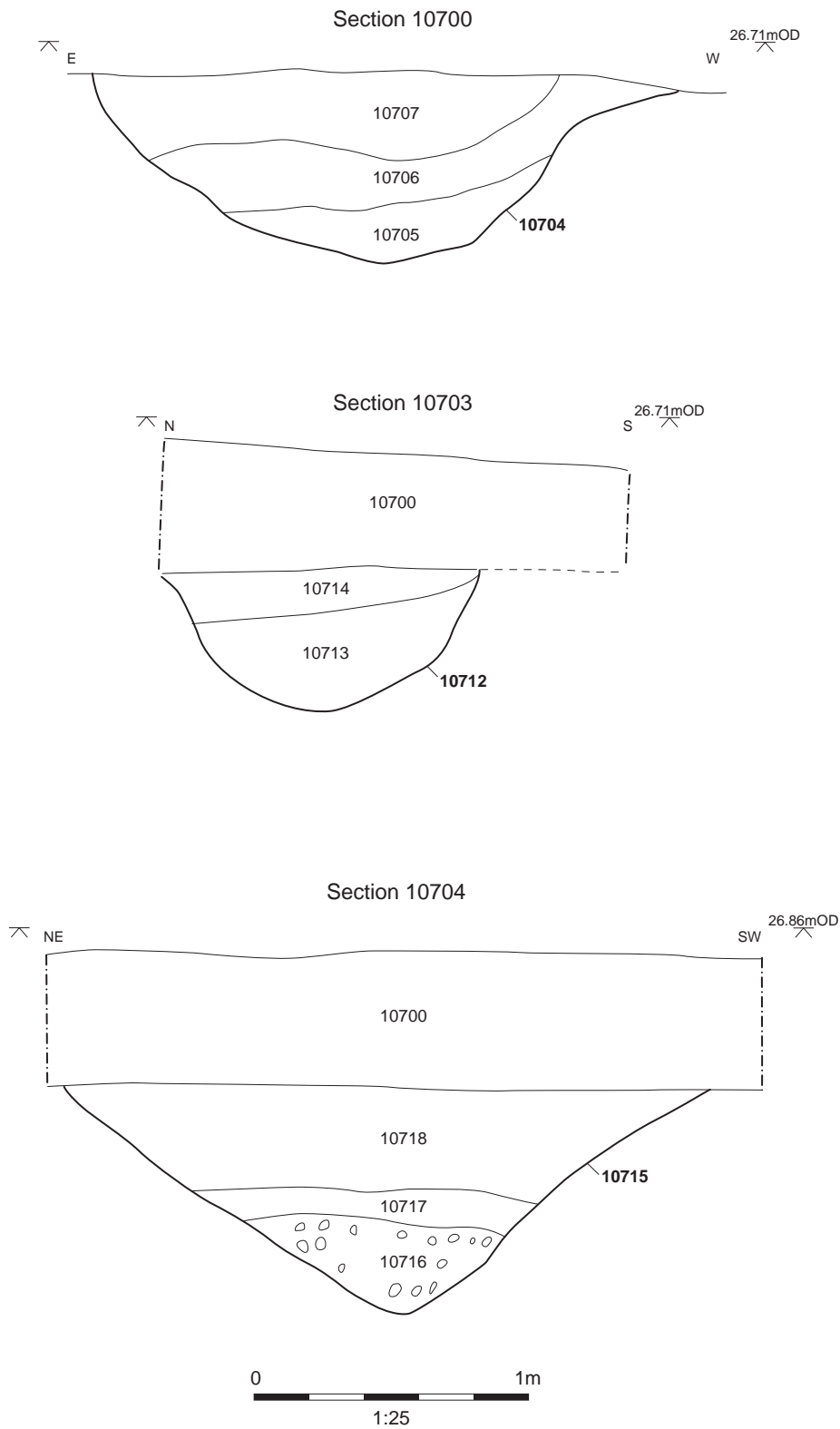

Figure 18: Sections (Trench 107)

- Site Boundary
- Evaluation trench
- Trench bottom
- Section line
- Intervention
- Feature
- Structure
- Truncation
- Deposit

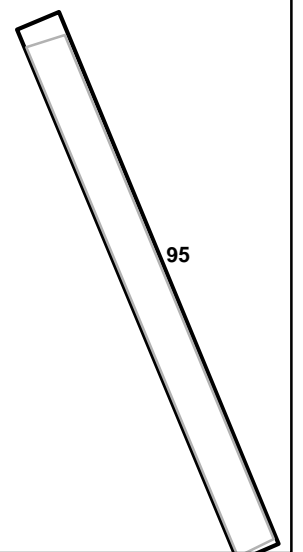
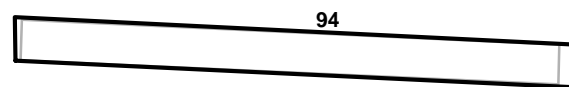
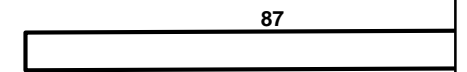
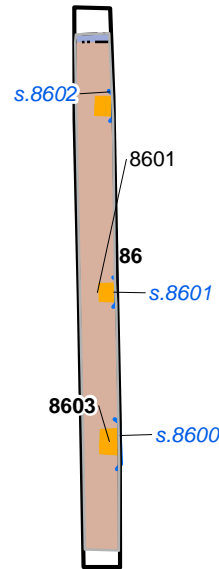
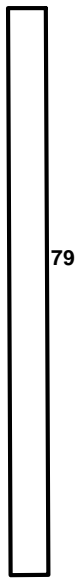
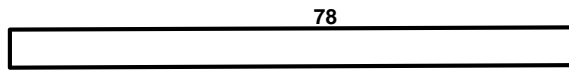
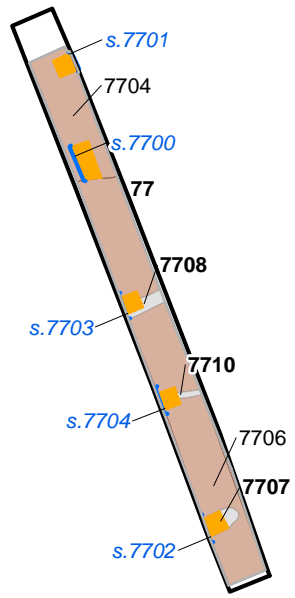
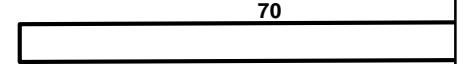
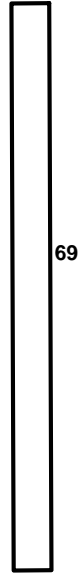
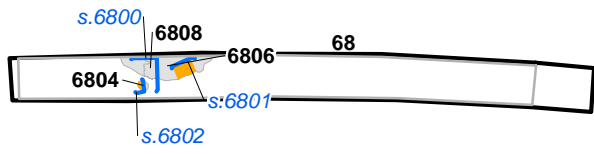
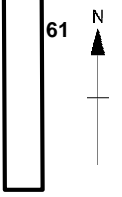

Figure 19: Plan of Trenches 68, 77 and 86

0 50m

1:400 @ A3

X:\ILTCEV_Lower_Thames_Crossing\010\Geomatics\03 GIS Projects - LTC41N20\Figures\LTC_Report_Figure19.mxd\aidan.farnan\06/09/2021

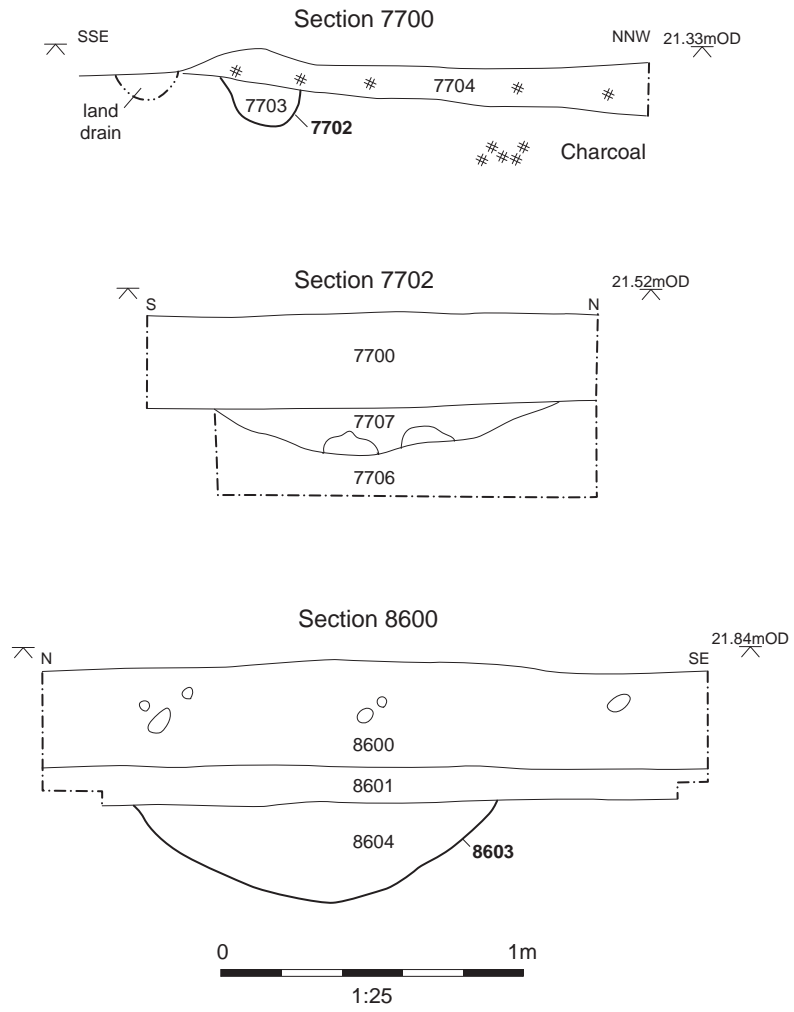
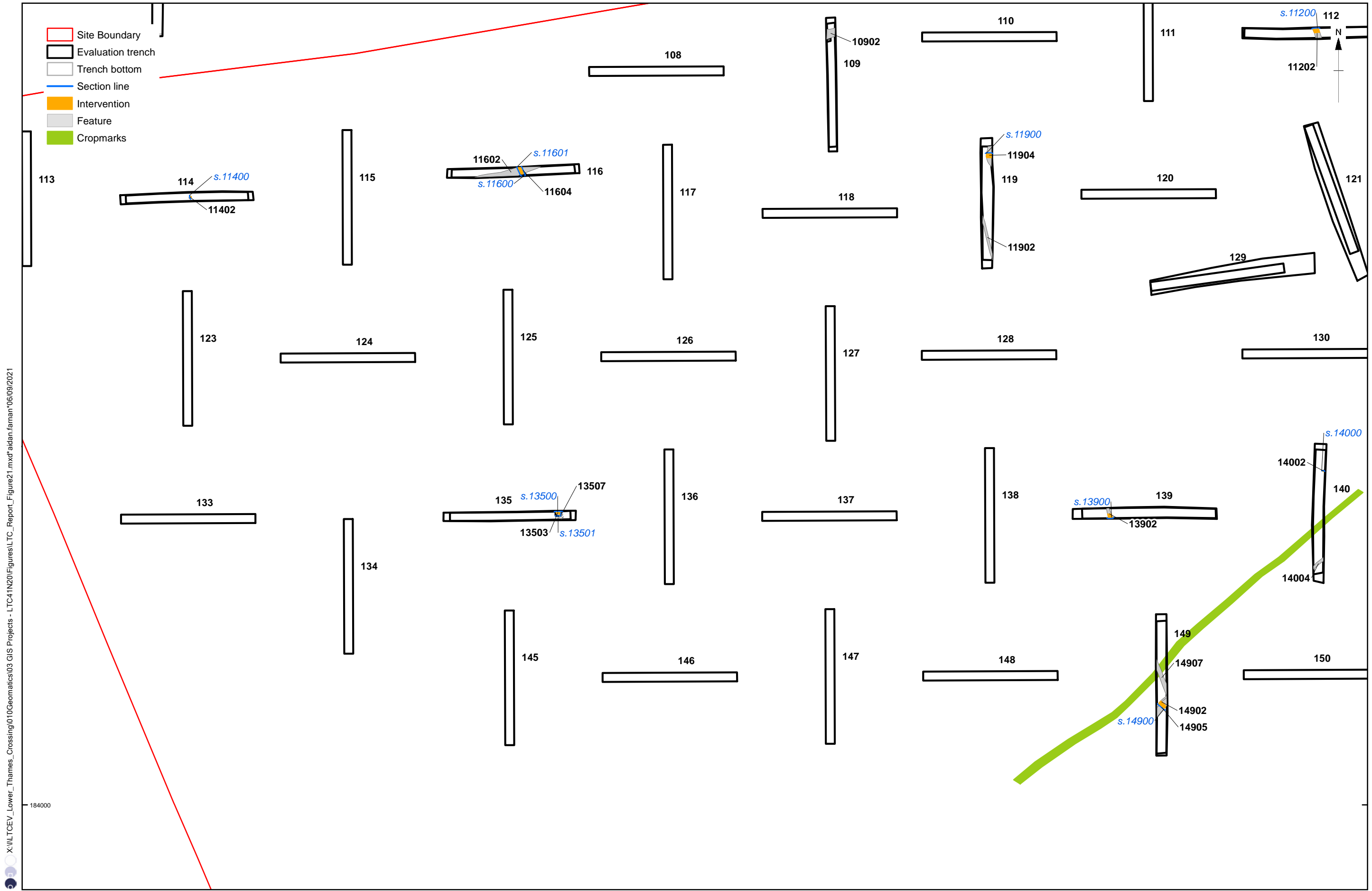

Figure 20: Sections (Trenches 77 and 86)



X:\ILTCEV_Lower_Thames_Crossing\010\Geomatics\03 GIS Projects - LTC41N20\Figures\LTC_Report_Figure21.mxd\aldan.farman\06/09/2021

Figure 21: Plan of Trenches 112, 114, 116, 119, 135, 140, 141 and 149

0 50m
1:800 @ A3

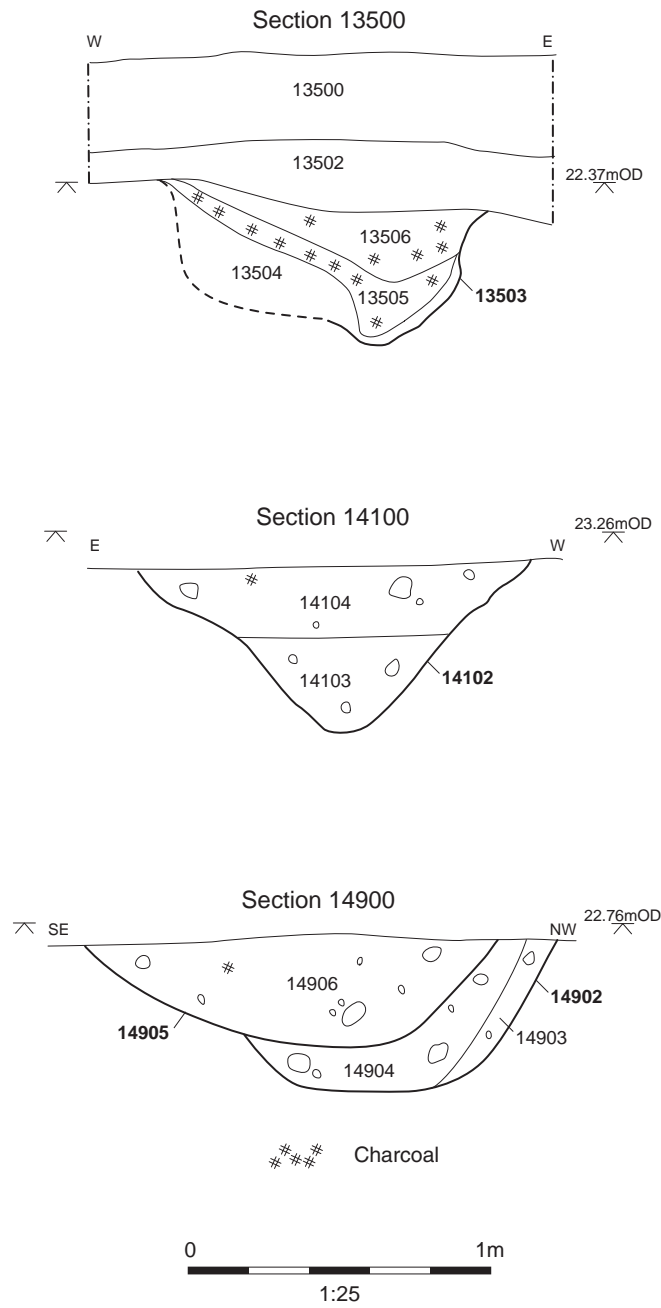

Figure 22: Sections (Trenches 135, 141 and 149)

X:\ILTCEV_Lower_Thames_Crossing\010Geomatics\03 GIS Projects - LTC41N20\Figures\LTC_Report_Figure23.mxd\arman\06/09/2021

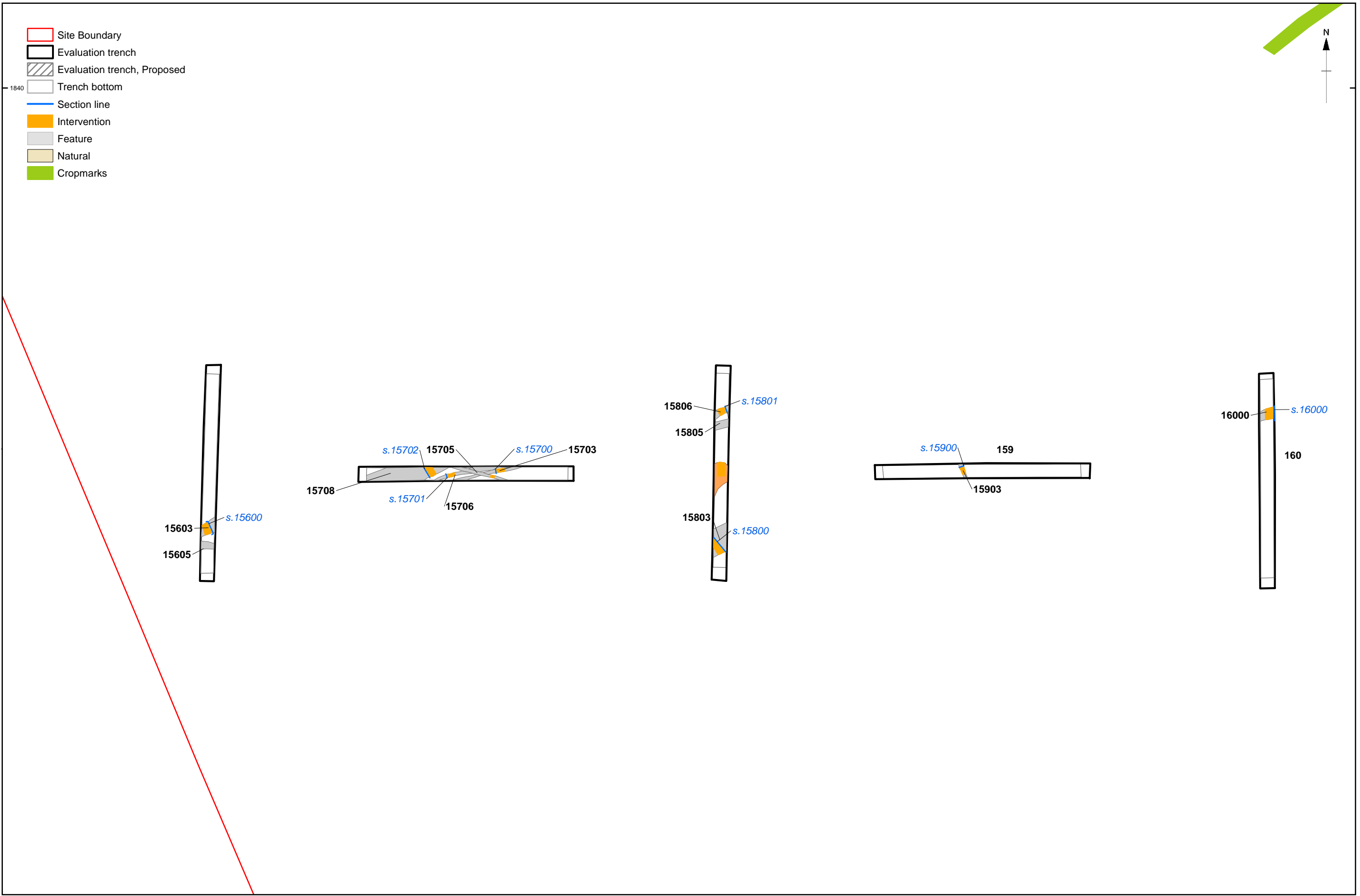

Figure 23: Plan of Trenches 156-160

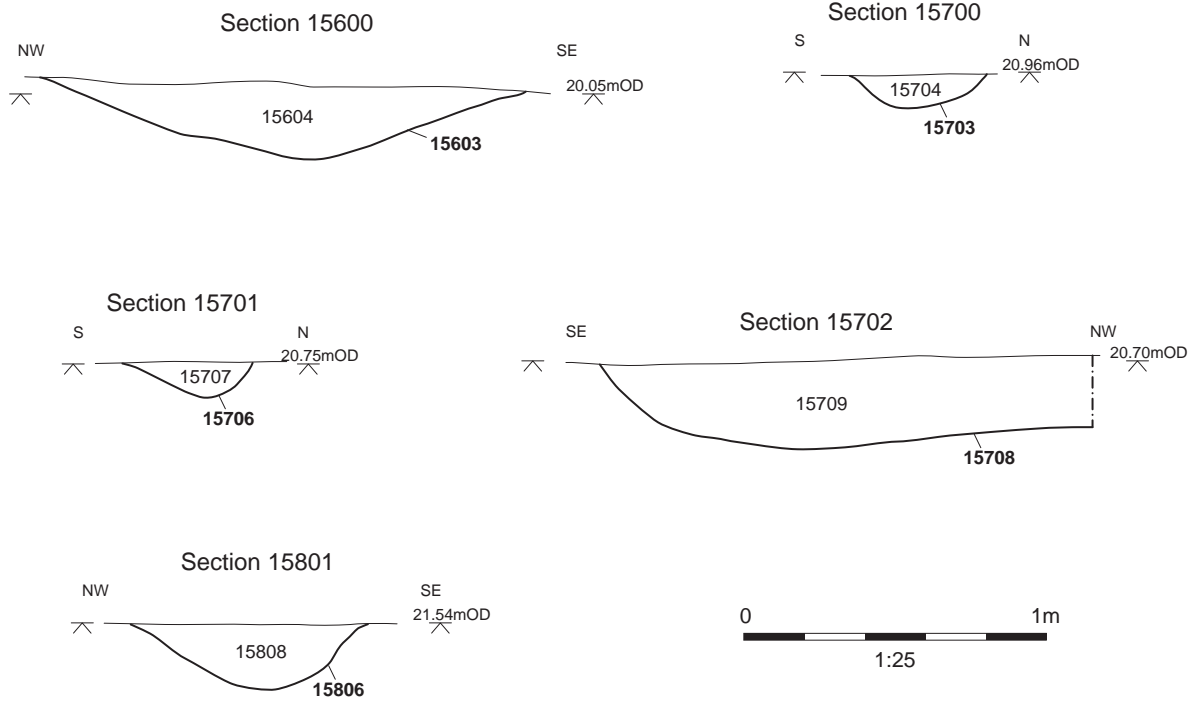

Figure 24: Sections 15600, 15700, 15702, 15801

X:\ILTCEV_Lower_Thames_Crossing\010\Geomatics\03 GIS Projects - LTC41N20\Figures\LTC_Report_FigureK.mxd*aldan*27/08/2021

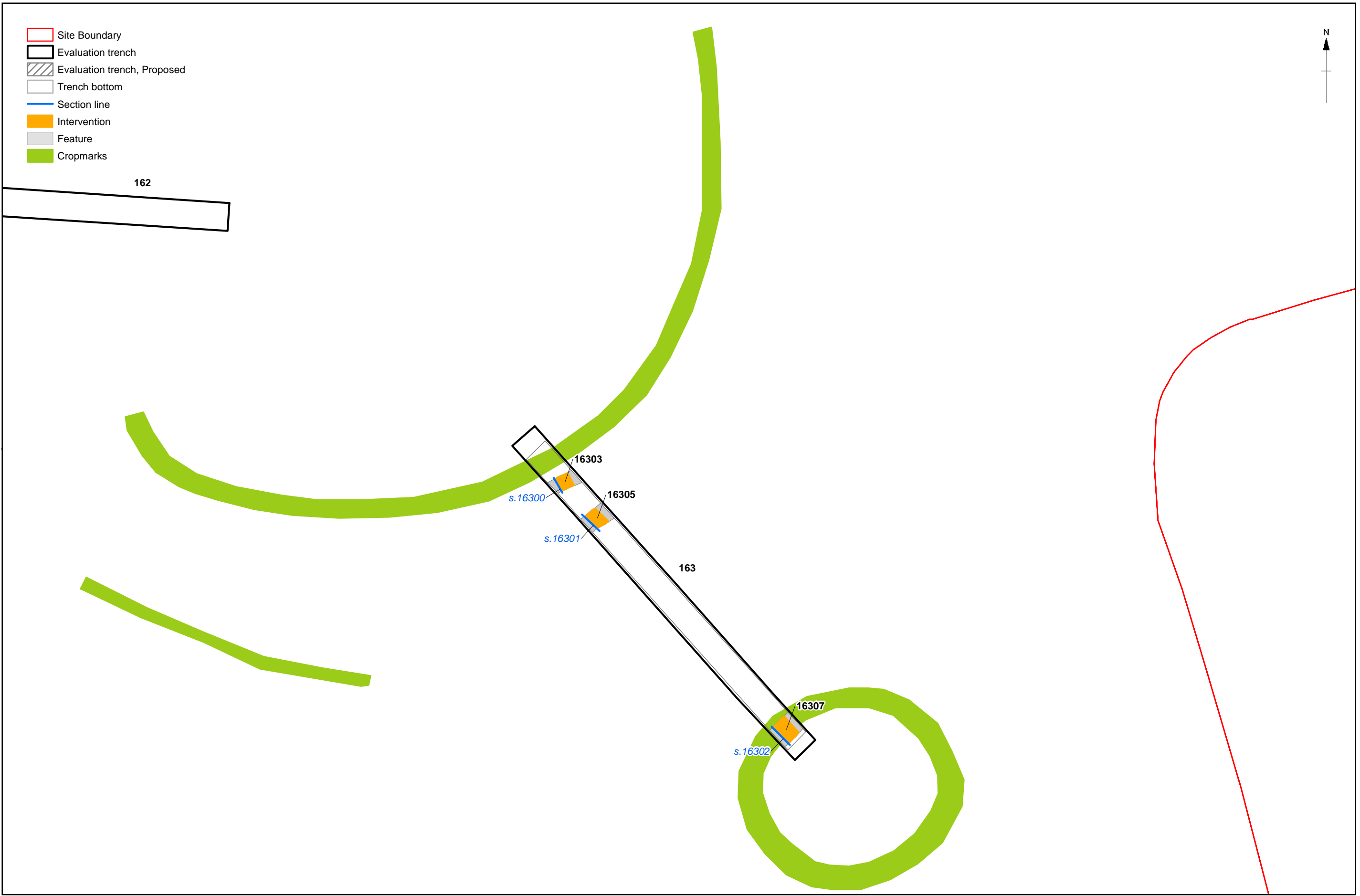

Figure 25: Plan of Trench 163

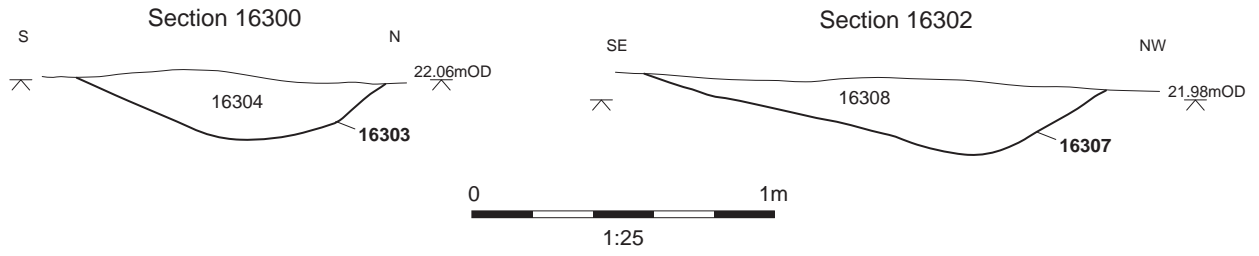

Figure 26: Sections 16300, 16302

X:\ILTCEV_Lower_Thames_Crossing\010Geomatics\03 GIS Projects - LTC41N20\Figures\LTC_Report_FigureM.mxd\aidan\27/08/2021

- Site Boundary
- Evaluation trench
- Evaluation trench, Proposed
- Trench bottom
- Section line
- Intervention
- Feature

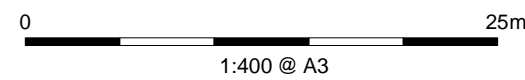
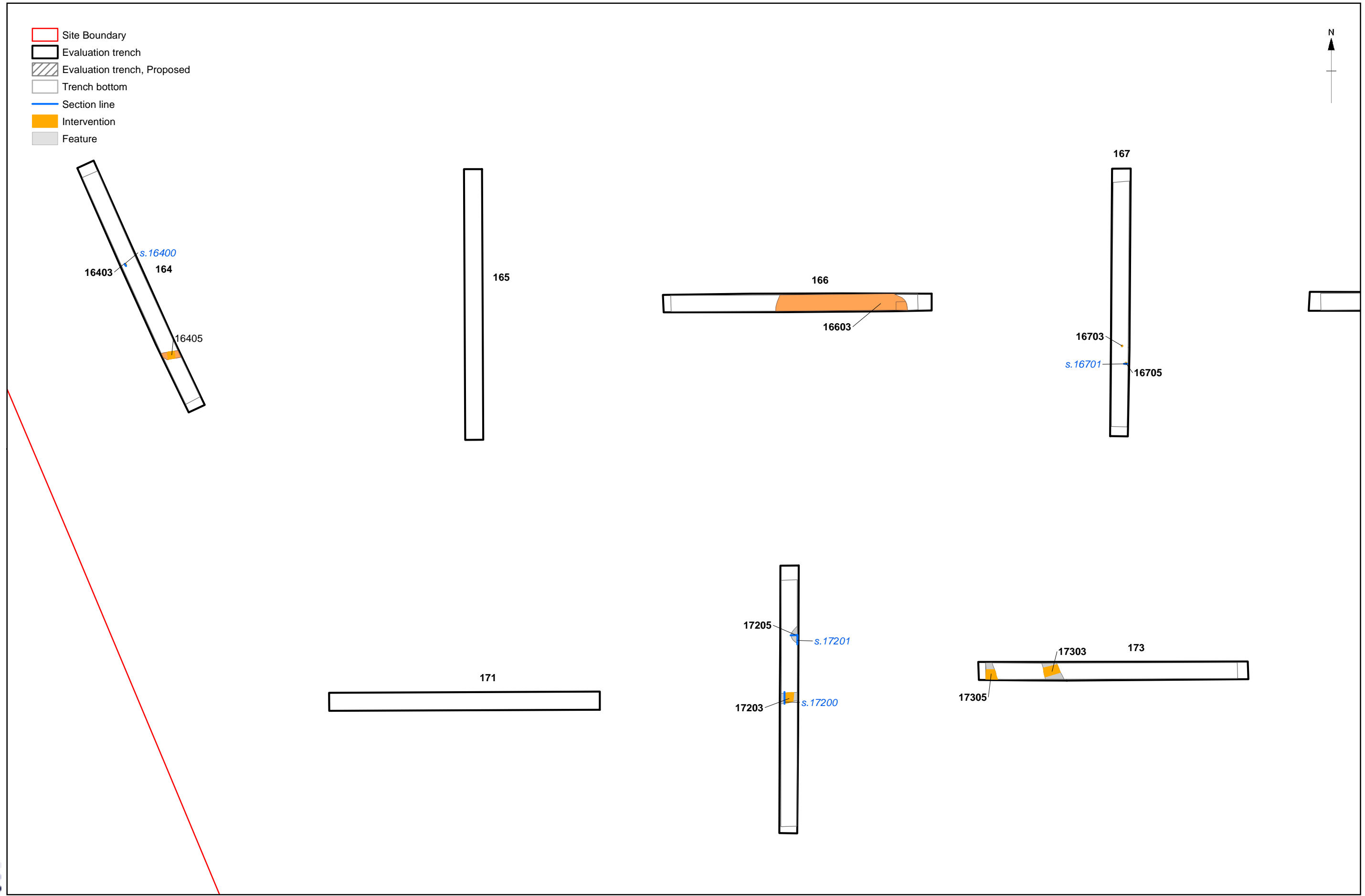

Figure 27: Plan of Trenches 164, 167, 172 and 173

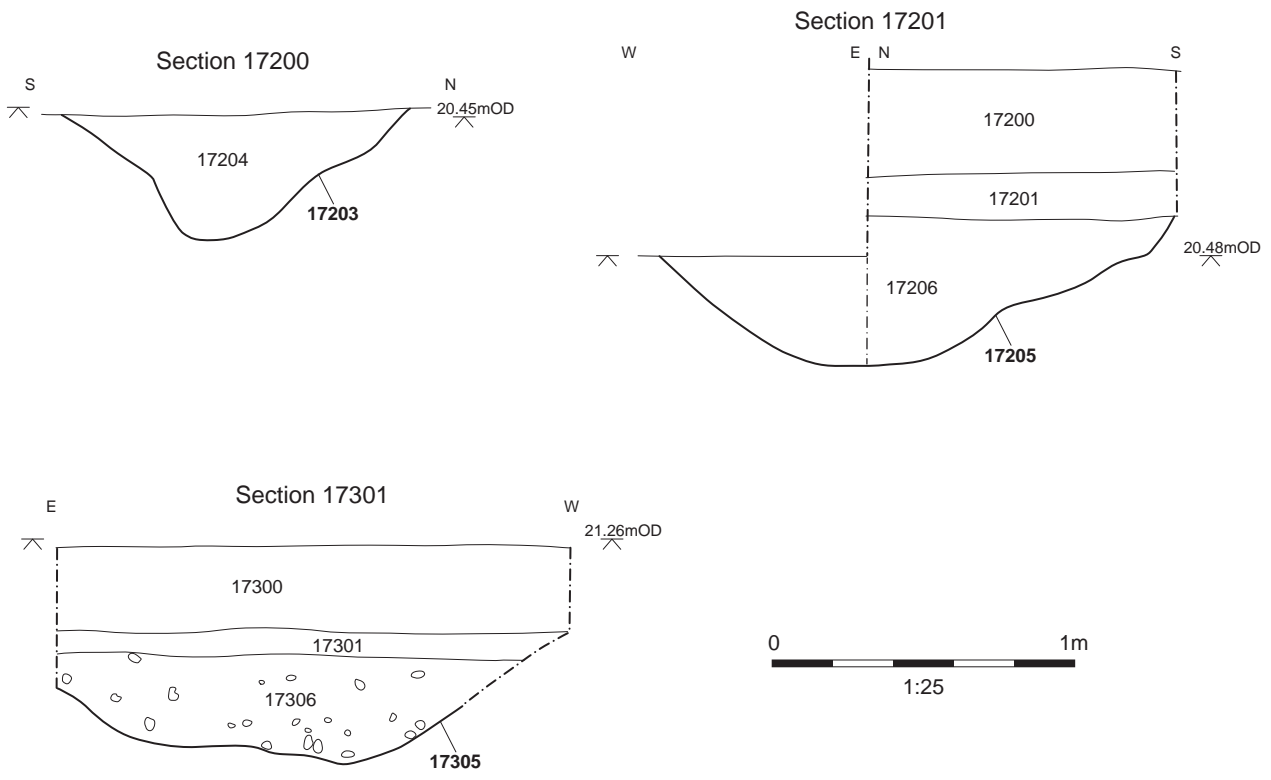

Figure 28: Sections 17200, 17201, 17301

X:\ILT\TCEV_Lower_Thames_Crossing\010\Geomatics\03 GIS Projects - LTC41\N20\Figures\LTC_Report_FigureO.mxd*aidan*27/08/2021

- Site Boundary
- Evaluation trench
- Evaluation trench, Proposed
- Trench bottom
- Section line
- Intervention
- Feature
- Natural

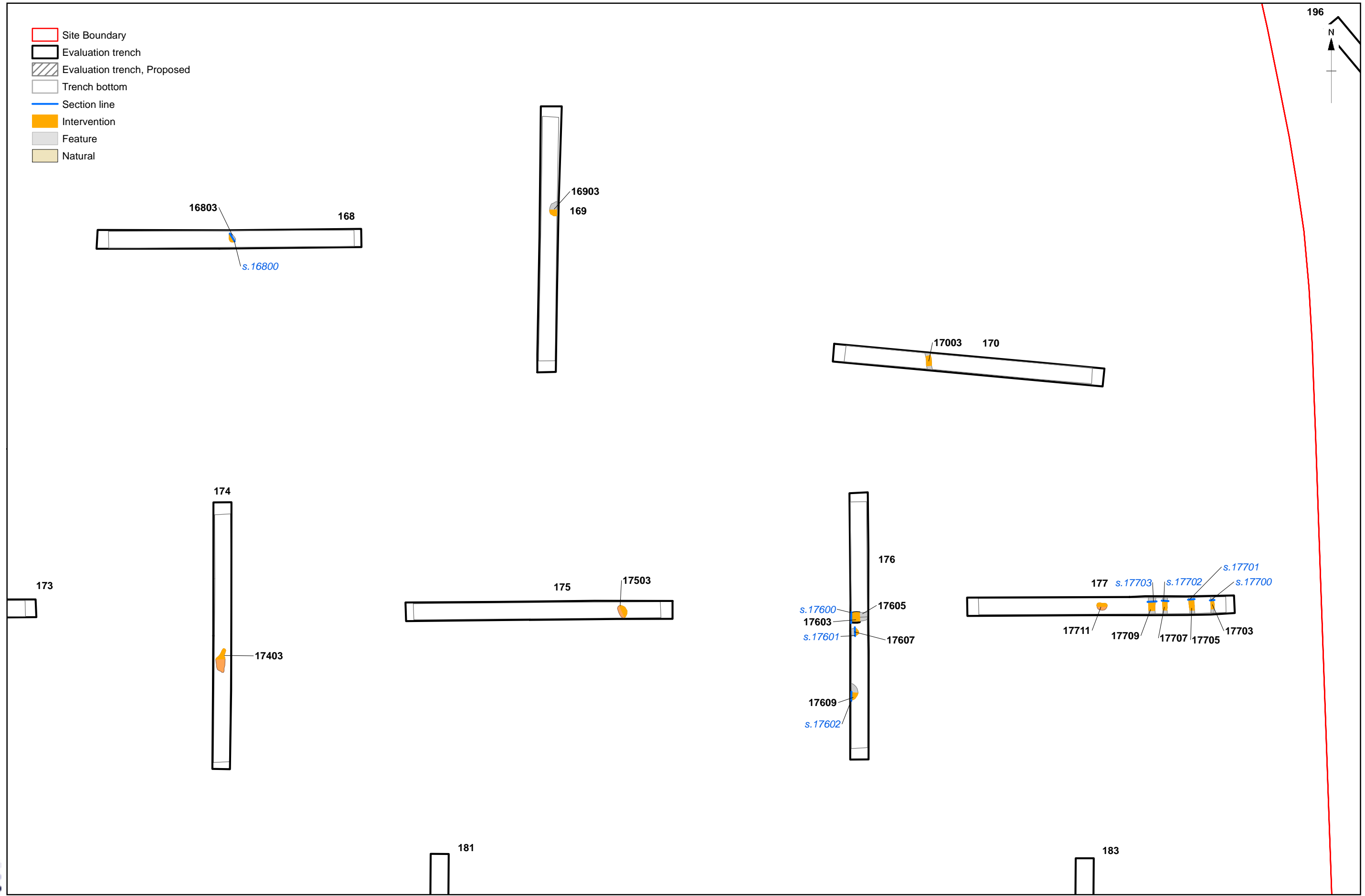
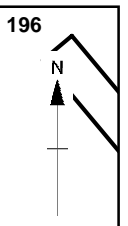

Figure 29: Plan of Trenches 168-170 and 174-177

- Site Boundary
- Evaluation trench
- Evaluation trench, Proposed
- Trench bottom
- Section line
- Intervention
- Feature
- Natural

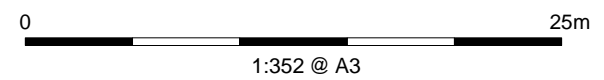
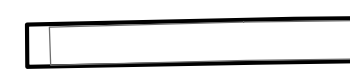
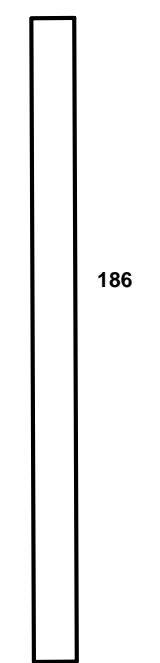
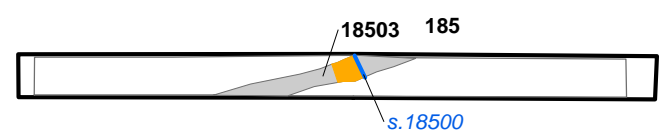
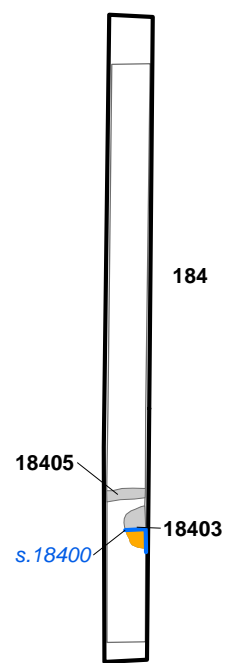
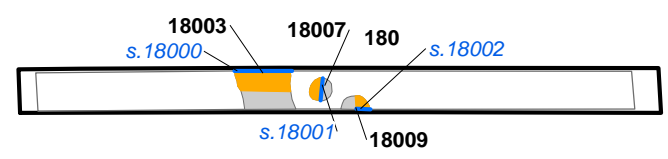
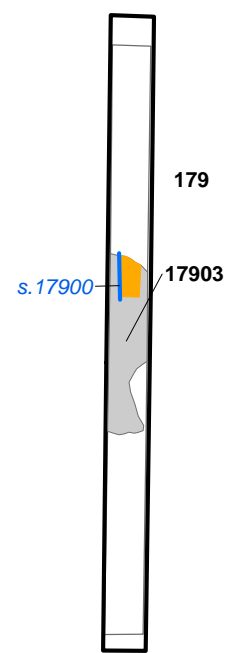
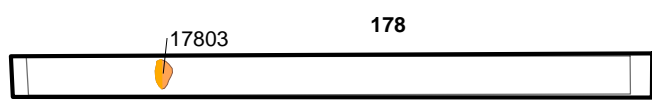

Figure 30: Plan of Trenches 178-180 and 184-186

X:\ILTCEV_Lower_Thames_Crossing\010Geomatics\03 GIS Projects - LTC41N20\Figures\LTC_Report_FigureP.mxd*aldan*27/08/2021

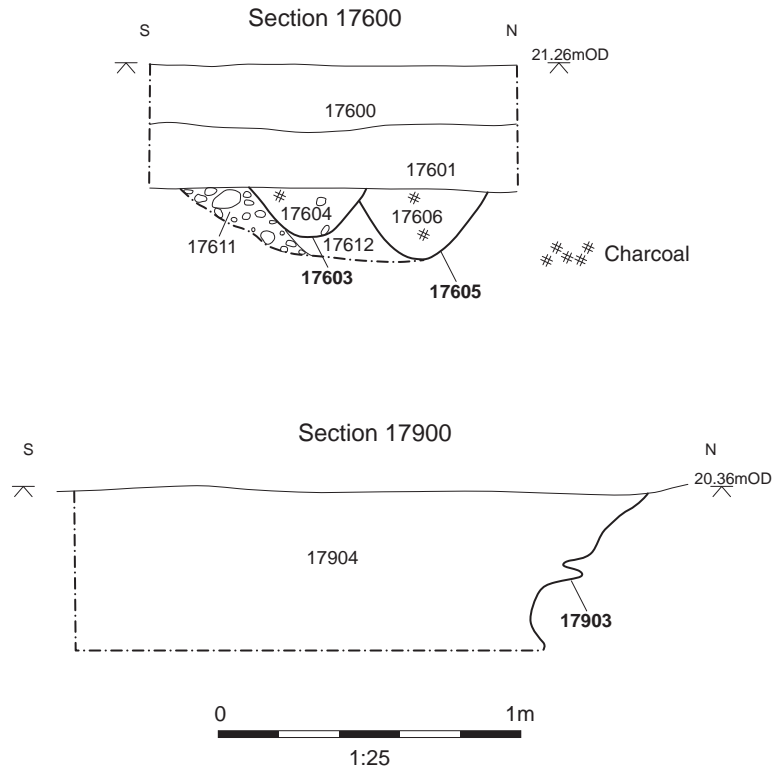
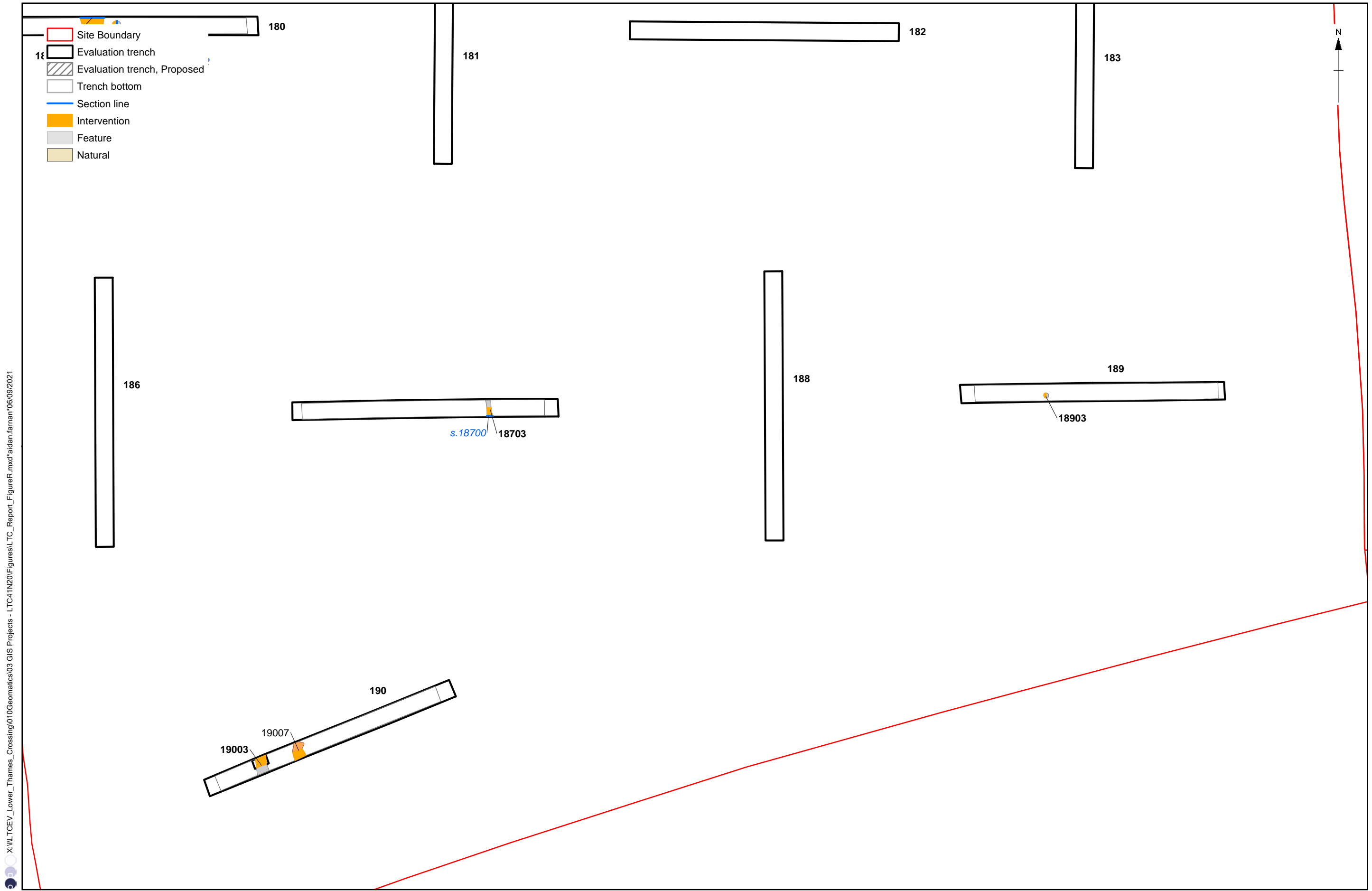

Figure 31: Sections 17600, 17900



X:\ILTCEV_Lower_Thames_Crossing\010Geomatics\03 GIS Projects - LTC41N20\Figures\LTC_Report_FigureR.mxd*aidan.farman*06/09/2021

Figure 32: Plan of Trenches 187, 189 and 190

0 25m
1:400 @ A3

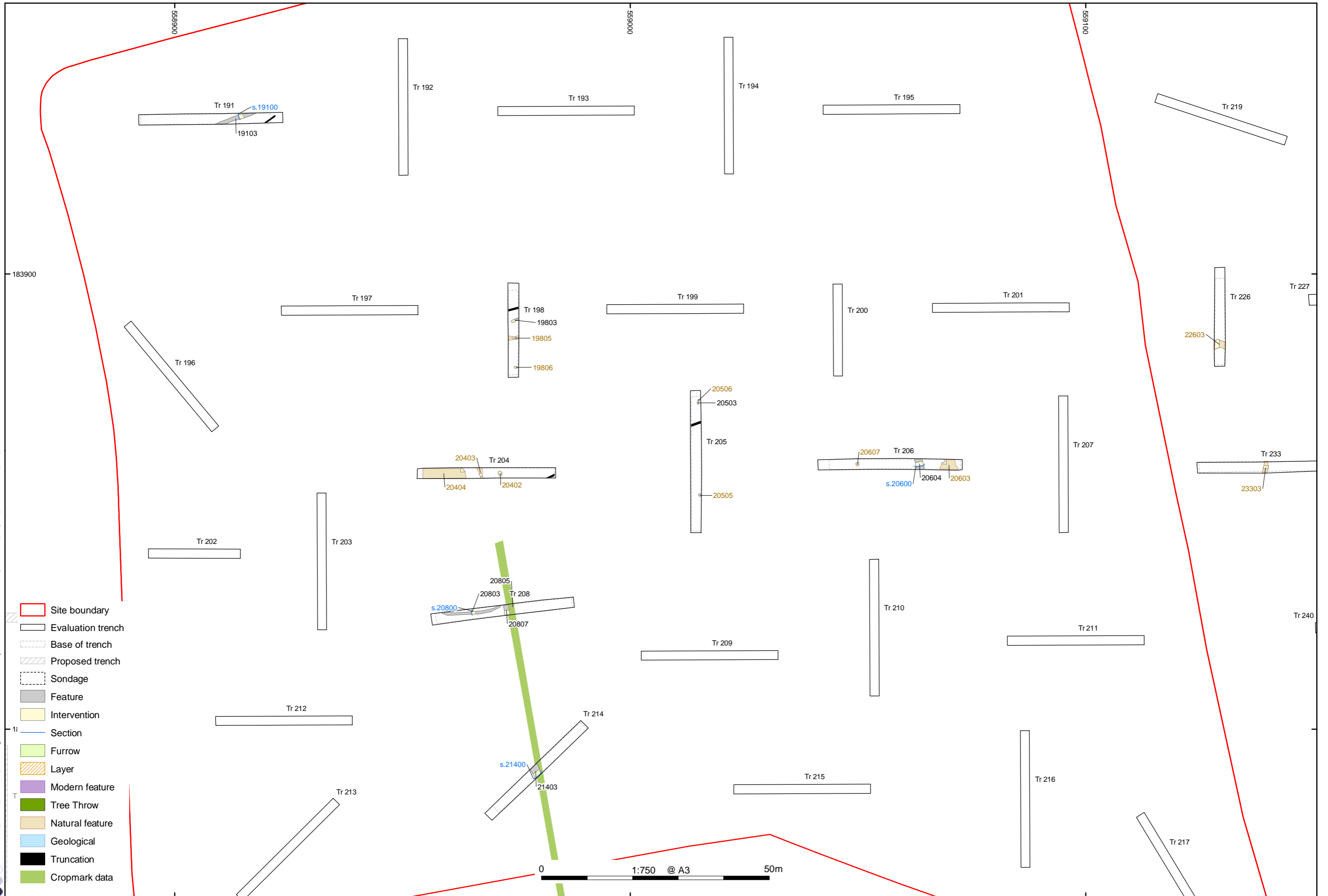

Figure 33: Plan of Trenches 191, 198, 204-6, 208 and 214

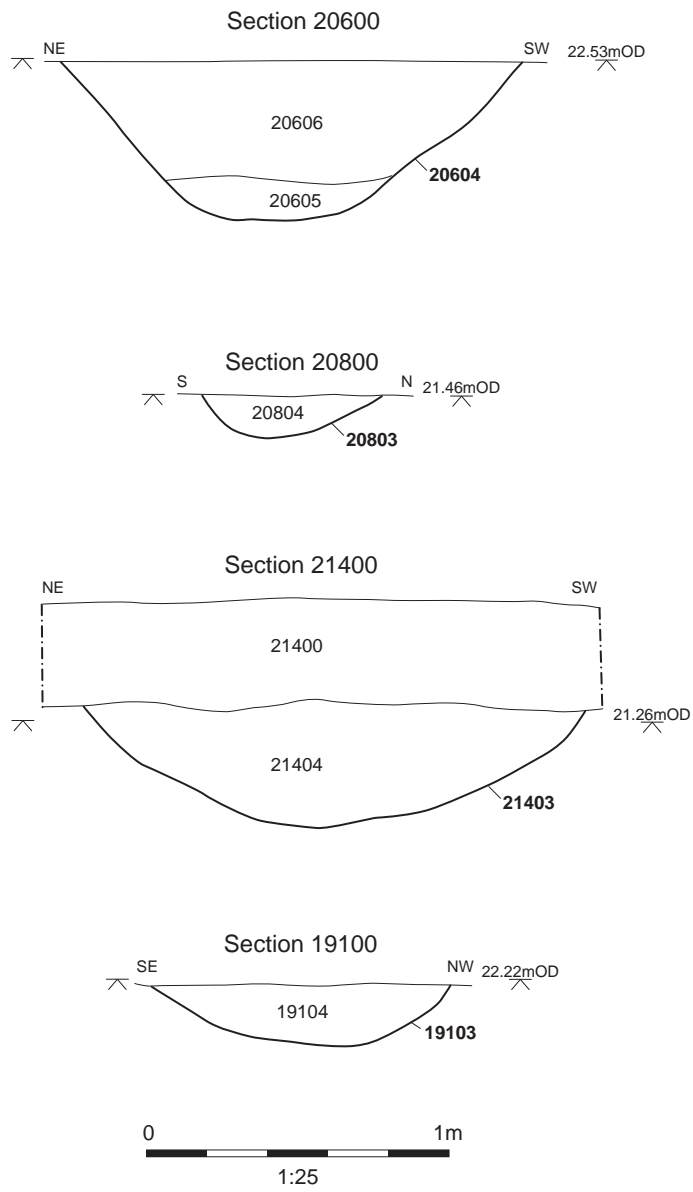
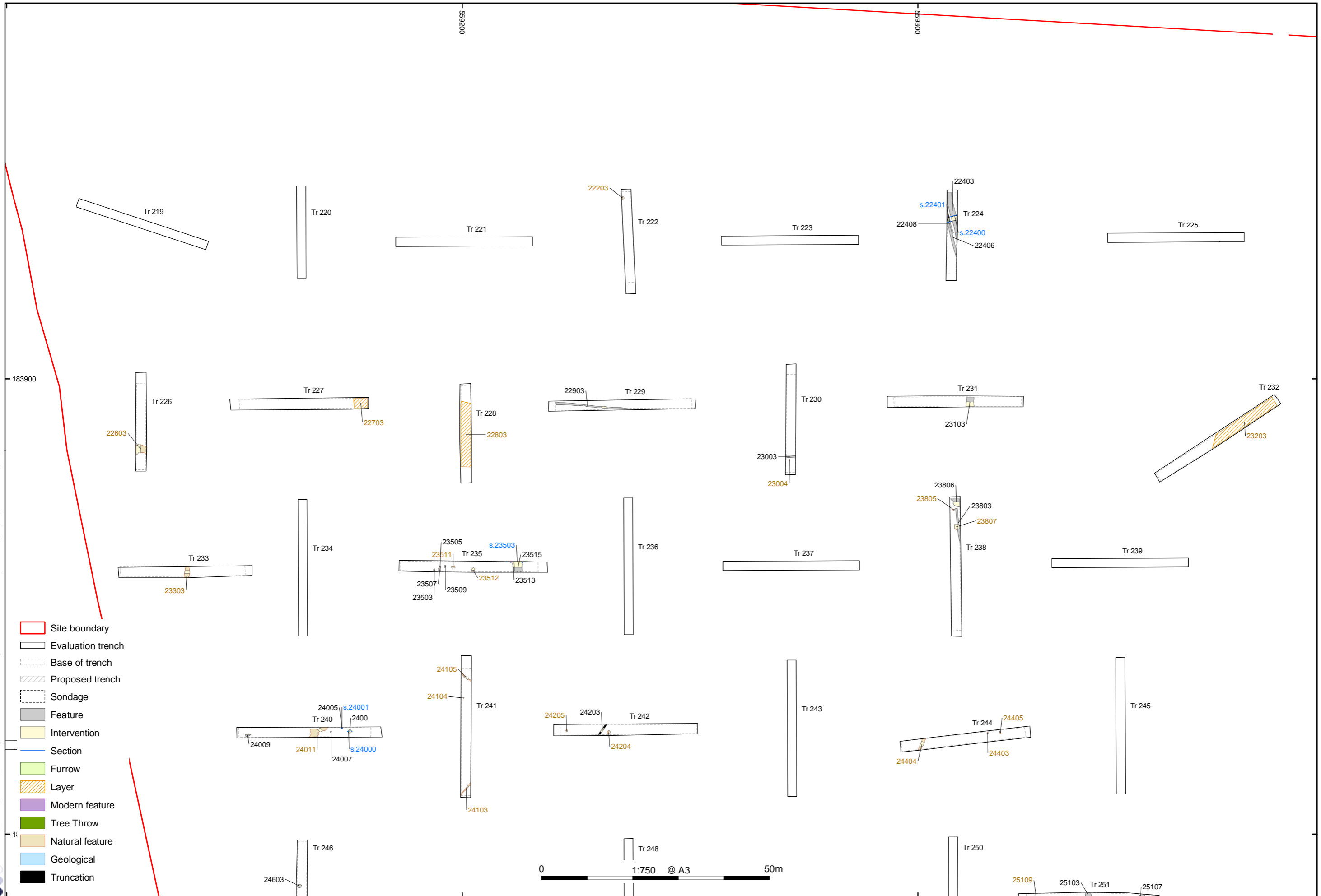

Figure 34: Sections (Trenches 206, 208, 214 and 191)

X:\ILTCEV_Lower_Themes_Crossing\010Geomatics\03 GIS Projects - LT C41N20\LT Reports\LT_Report_TrenchPlans_DD_A31.mxd\aidan.faman\07/01/2021



- Site boundary
- Evaluation trench
- Base of trench
- Proposed trench
- Sondage
- Feature
- Intervention
- Section
- Furrow
- Layer
- Modern feature
- Tree Throw
- Natural feature
- Geological
- Truncation

Figure 35: Plan of Trenches 224, 227-32, 235 and 238

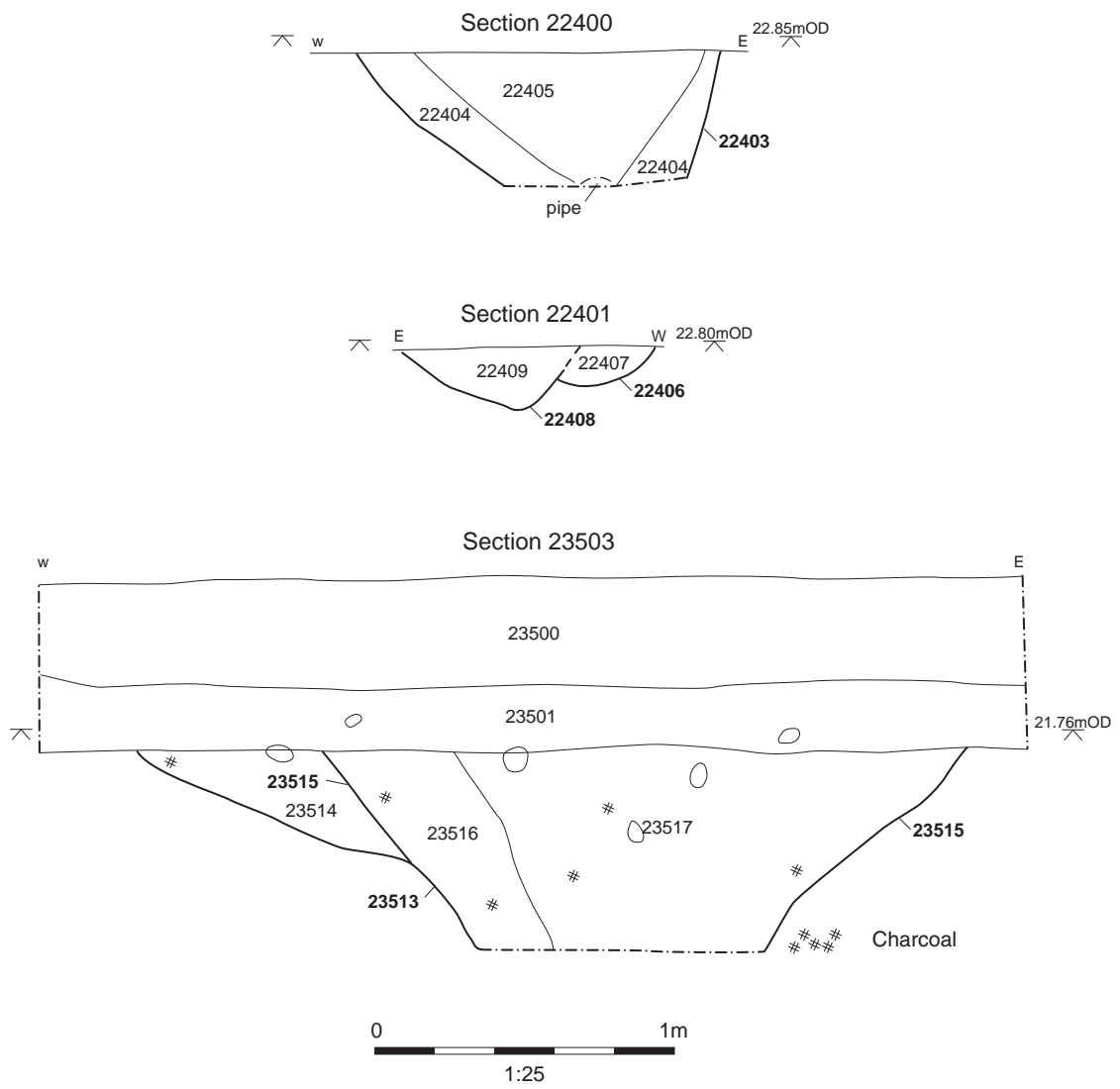
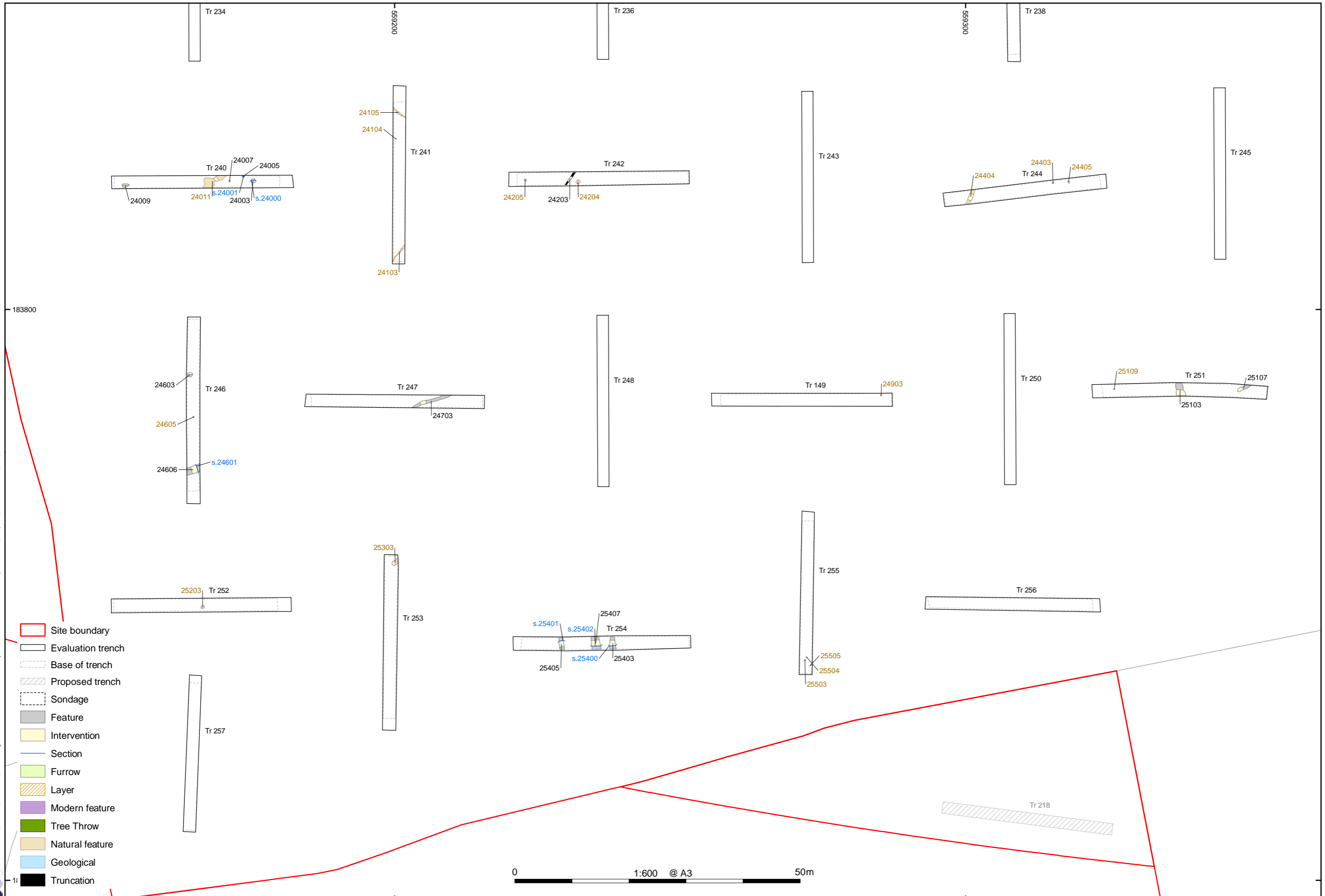

Figure 36: Sections (Trenches 224 and 235)

X:\ILTCEV_Lower_Thames_Crossing\010Geomatics\03 GIS Projects - LT C41N20\UTC Reports\UTC_Report_TrenchPlans_DD_A31.mxd\aidan.faman\07/01/2021



- Site boundary
- Evaluation trench
- Base of trench
- Proposed trench
- Sondage
- Feature
- Intervention
- Section
- Furrow
- Layer
- Modern feature
- Tree Throw
- Natural feature
- Geological
- Truncation

0 1:600 @ A3 50m

Contains Ordnance Survey data © Crown copyright and database right 2021

Figure 37: Plan of Trenches 240, 246, 247, 251 and 254

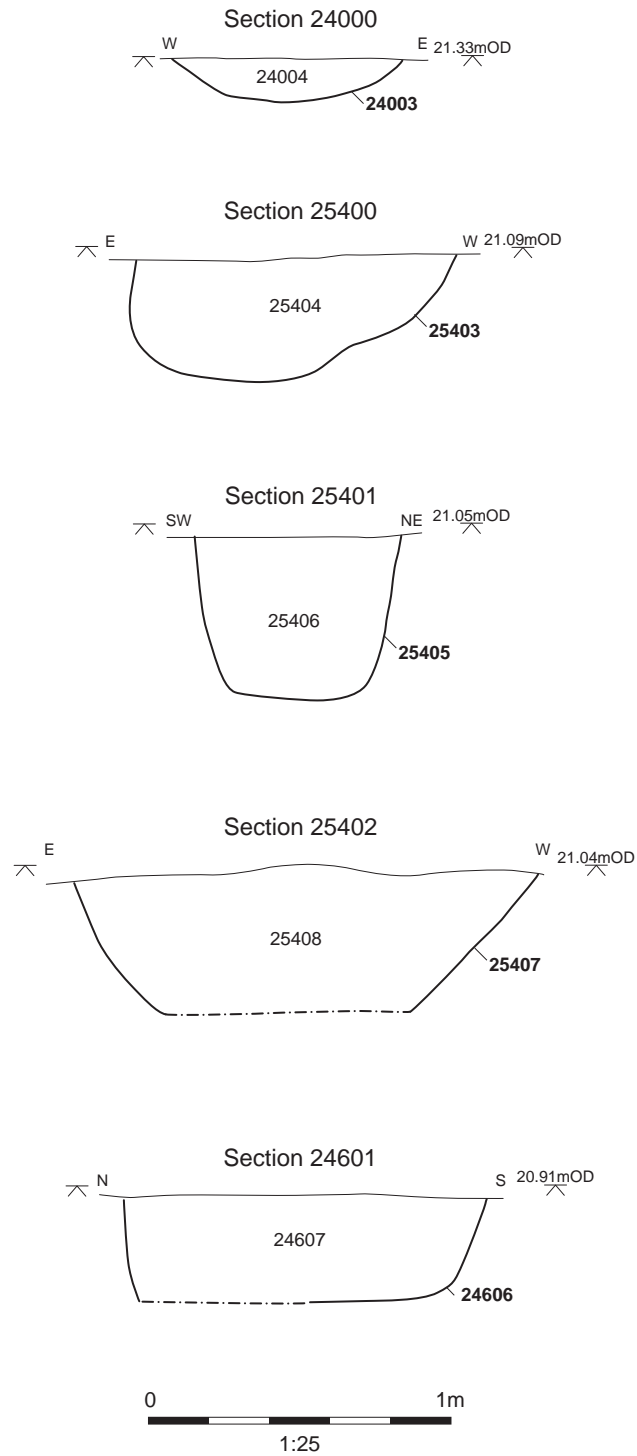
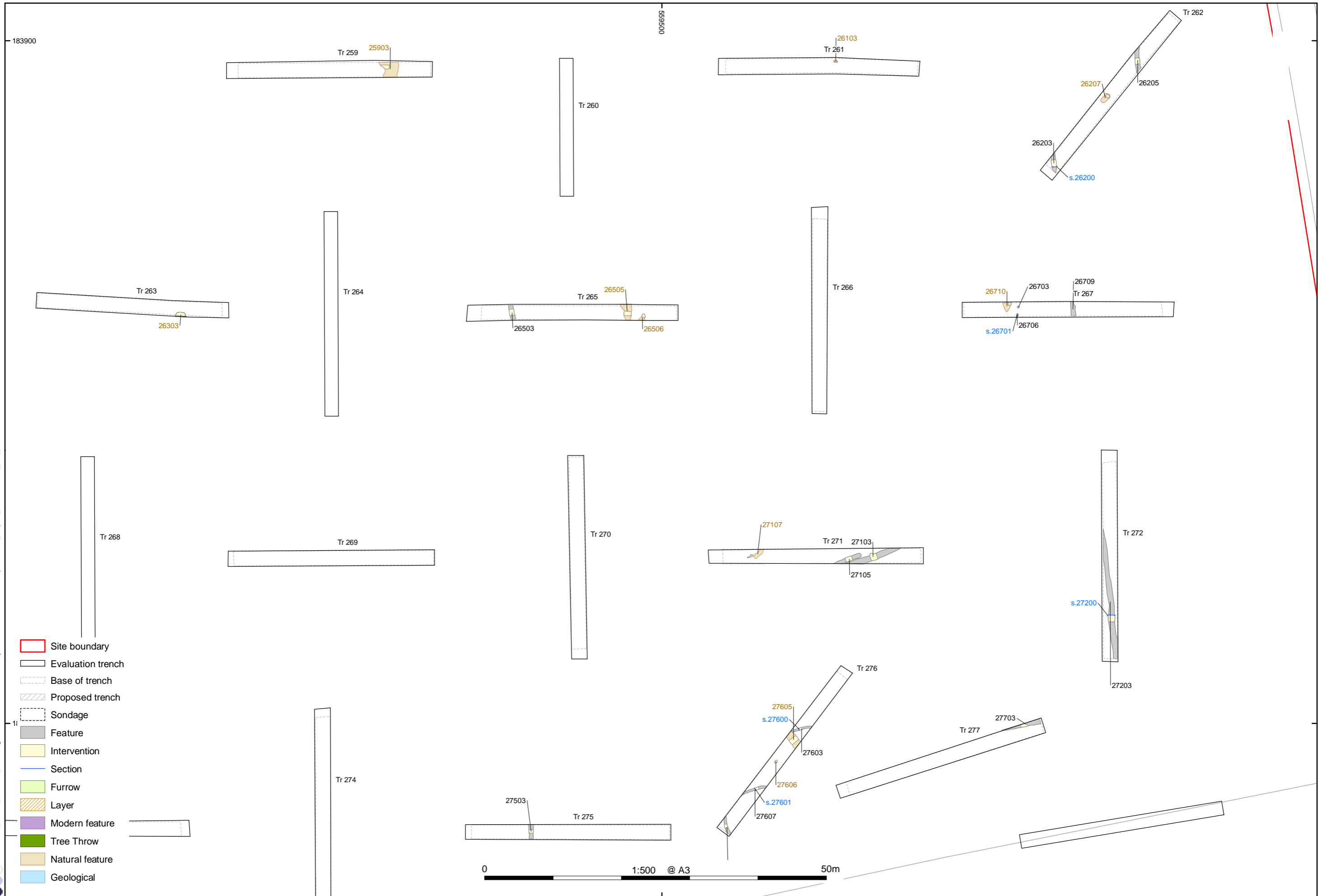

Figure 38: Sections (Trenches 240, 246 and 254)



Contains Ordnance Survey data © Crown copyright and database right 2021

Figure 39: Plan of Trenches 262, 265, 267, 271-2, and 275-7

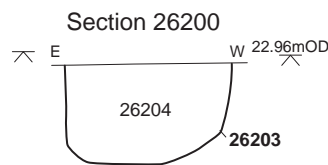
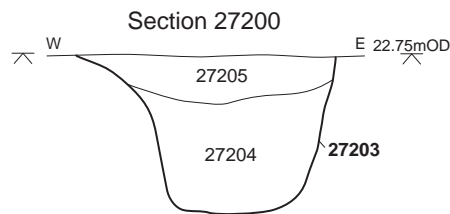
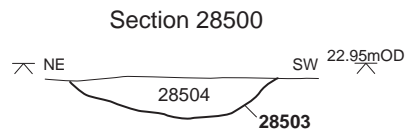
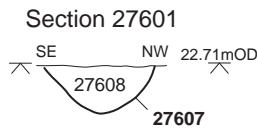
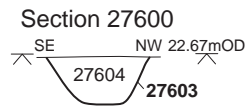
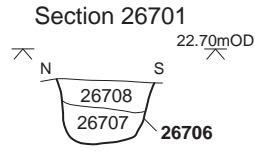
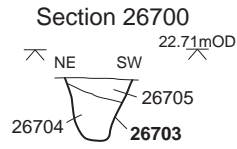

Figure 40: Sections (Trenches 262, 267, 272, 276 and 285)

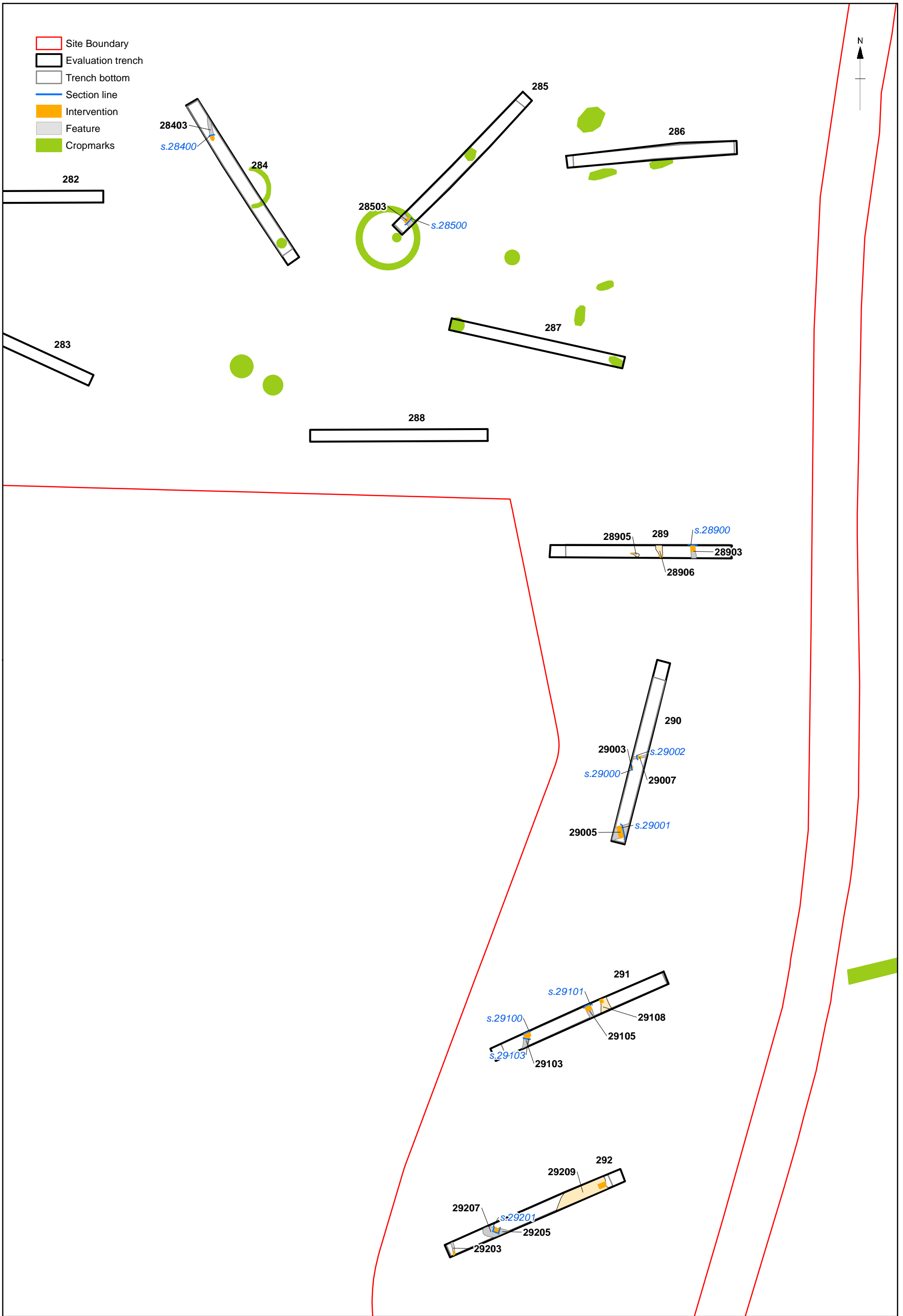
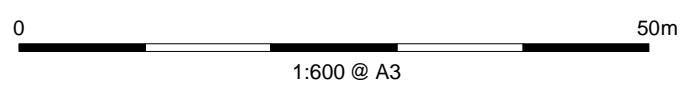

Figure 41: Plan of Trenches 284-5 and 289-92



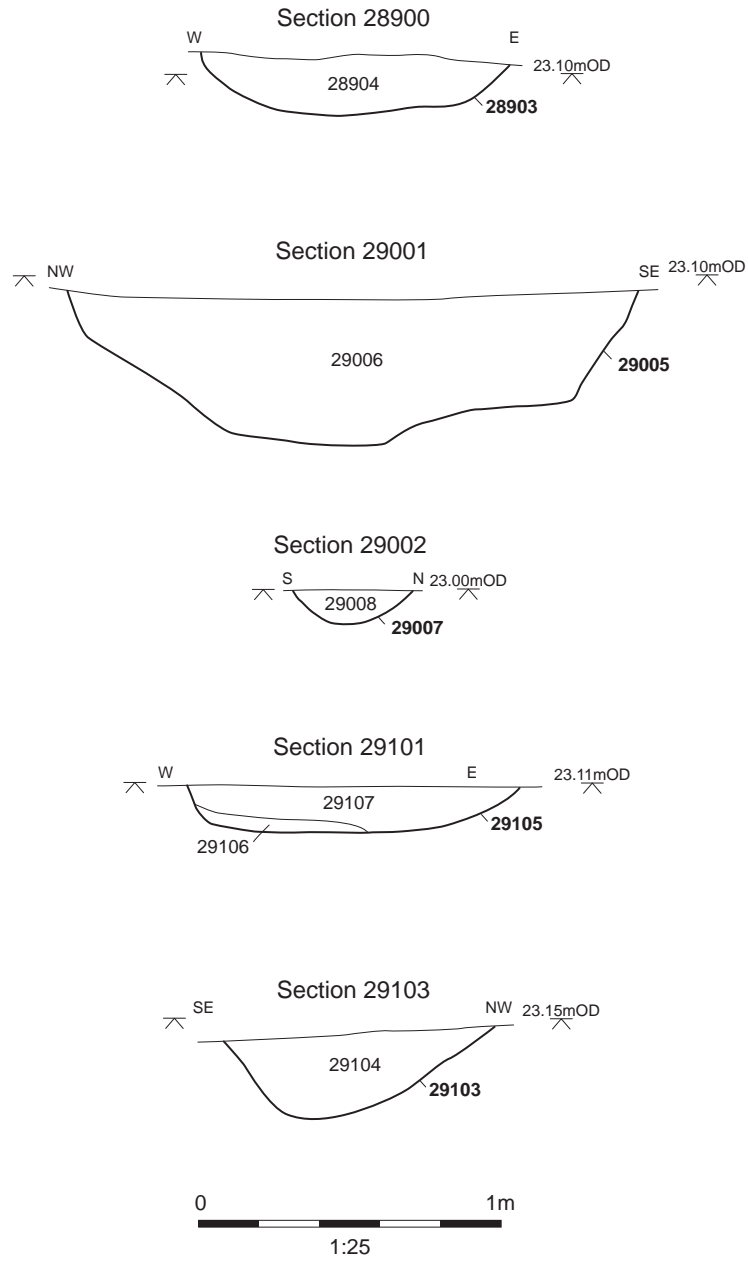
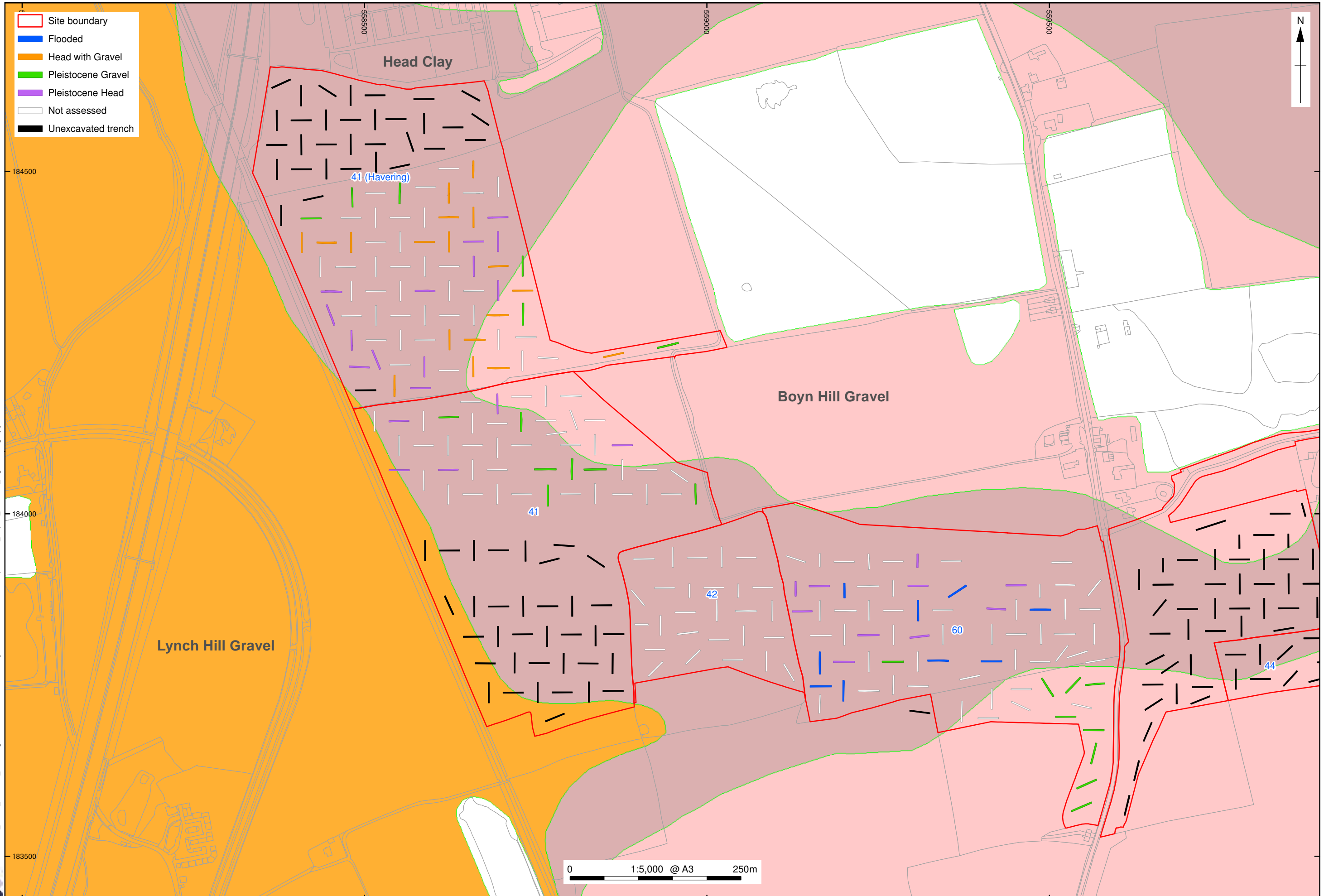

Figure 42: Sections (Trench 289, 290 and 291)



X:\ILTCEV_Lower_Thames_Crossing\010\Geomatics\03 GIS Projects - LT\41N20\LT\TC_Reports\LT_TC_Report_Geotech_Fig25.mxd*gary.jones*16/12/2020

Contains Ordnance Survey data © Crown copyright and database right 2020, provided by client.
Contains British Geological Survey materials © UKRI 2020

Figure 43 : Results of geoaerchaeological investigation

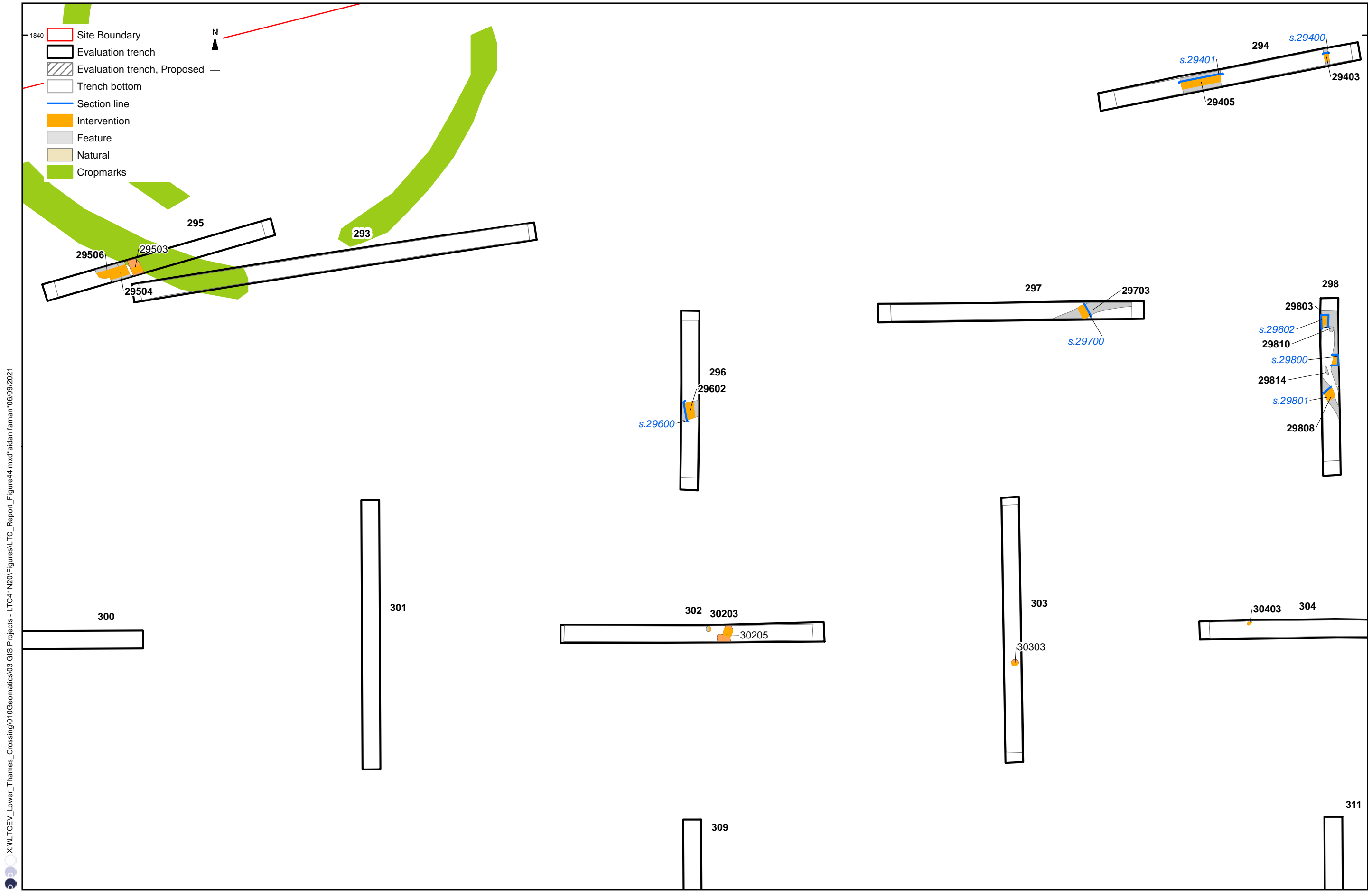

X:\ILTCEV_Lower_Thames_Crossing\010\Geomatics\03 GIS Projects - LTC41N20\Figures\LTC_Report_Figure44.mxd\aldan.farman\06/09/2021

Figure 44: Plan of Trenches 294-298

0 25m
1:400 @ A3

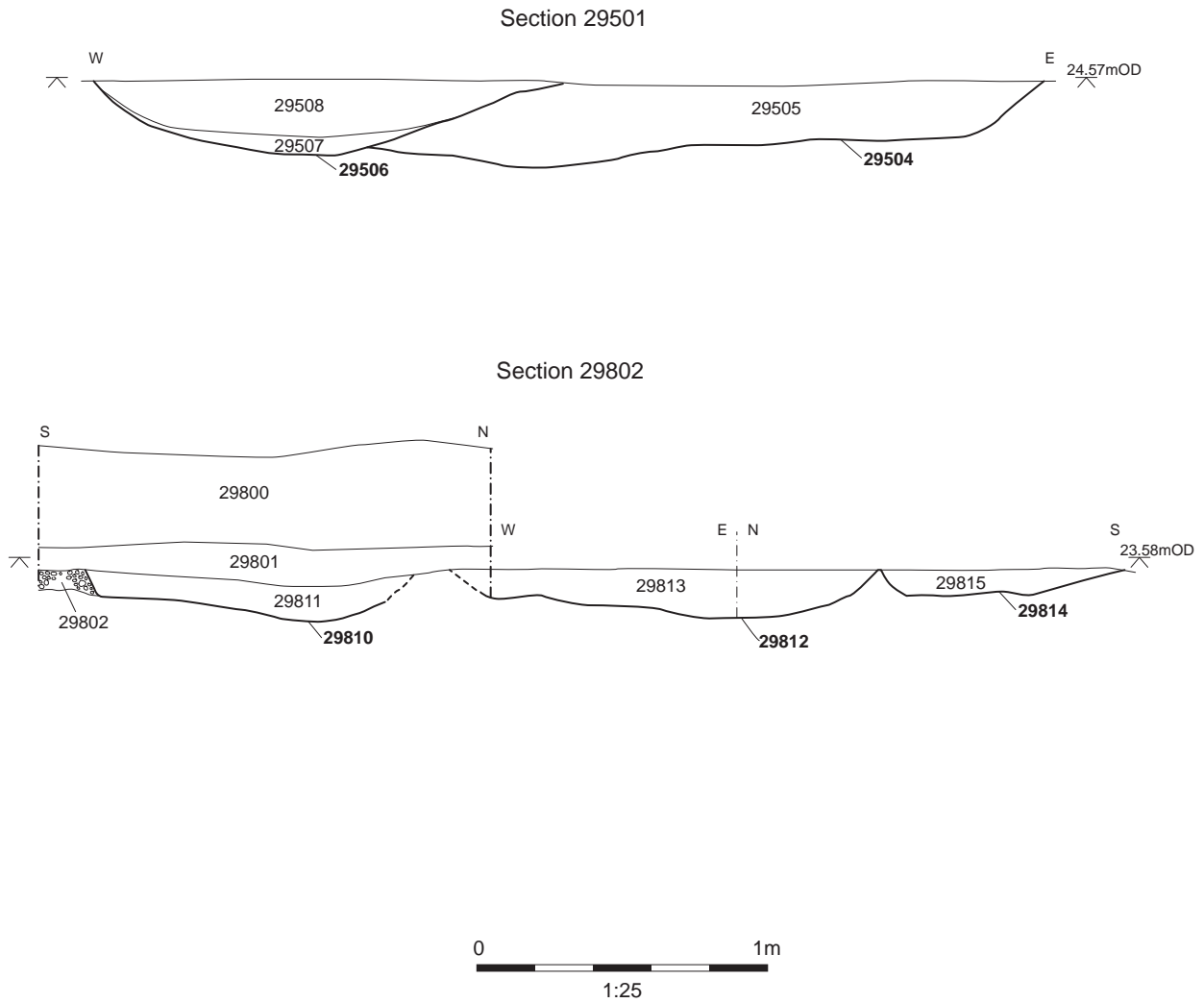
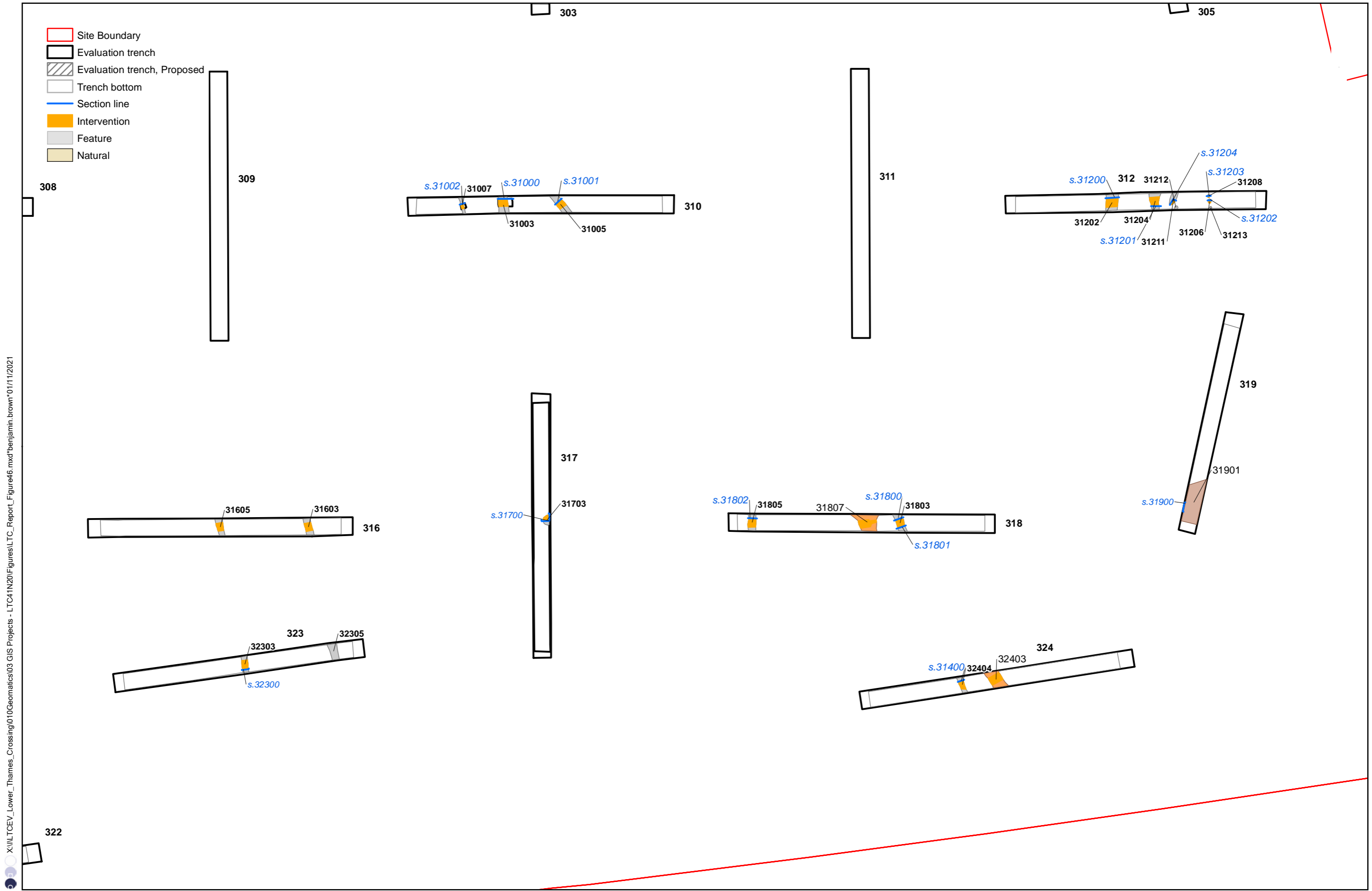
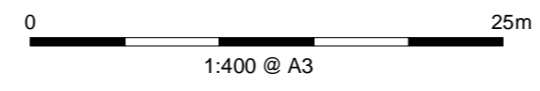

Figure 45: Sections (Trenches 295 and 298)



X:\ILTCEV_Lower_Thames_Crossing\010Geomatics\03 GIS Projects - LTC41N20\Figures\LTC_Report_Figures\Figures\benjamin.brown\01/11/2021

Figure 46: Plan of Trenches 310, 312, 316-319, 323 and 324



- Site Boundary
- Evaluation trench
- Trench bottom
- Section line
- Intervention

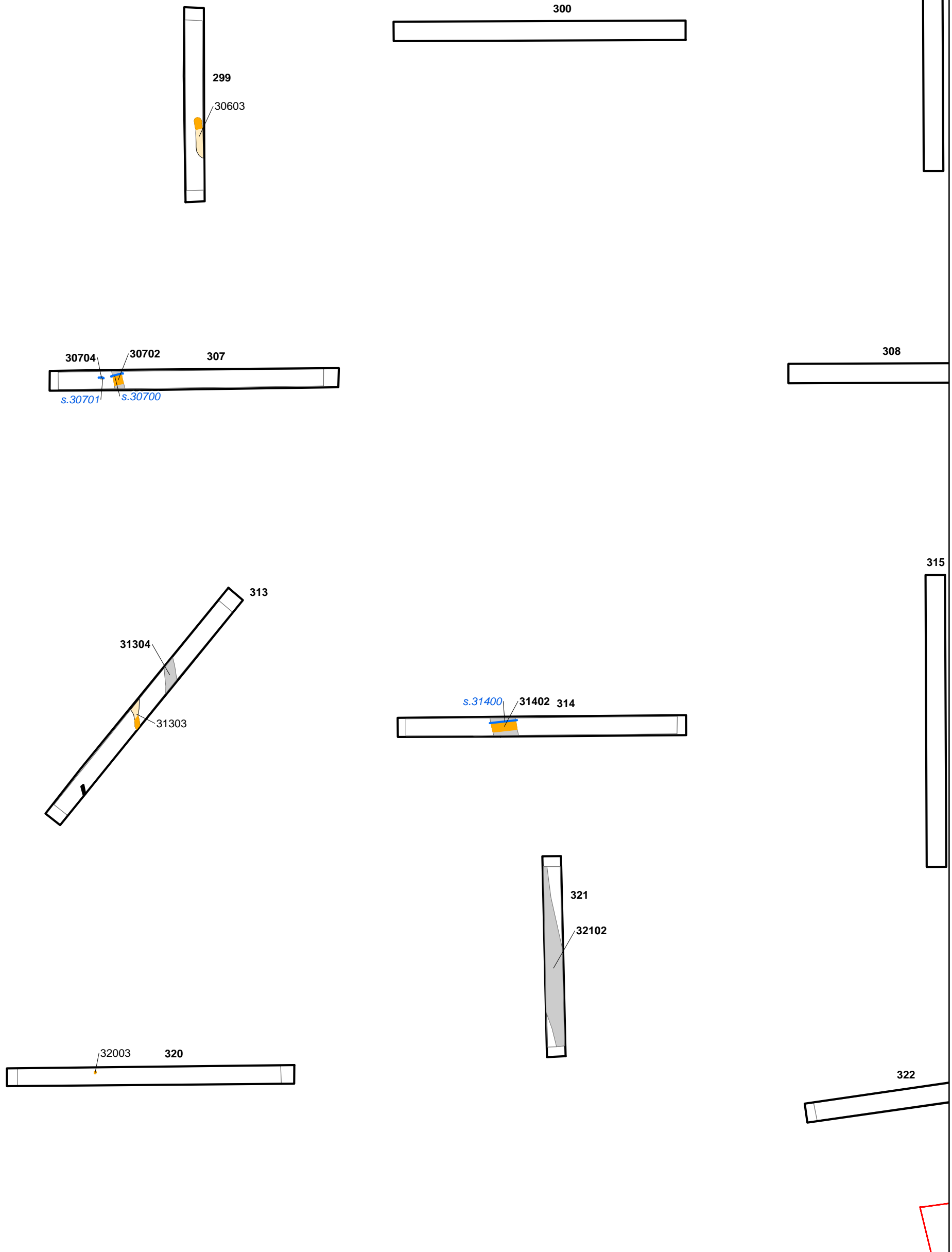
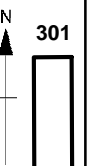
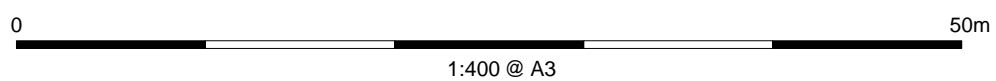

Figure 47: Plan of Trenches 299, 306, 307, 313, 314, 320 and 321



X:\ILT\TCEV_Lower_Thames_Crossing\010\Geomatics\03 GIS Projects - LTC41N20\Figures\LTC_Report_Figure48.mxd\aldan.farman\27/08/2021

- Site Boundary
- Evaluation trench
- Trench bottom
- Section line
- Intervention
- Feature
- Cropmarks

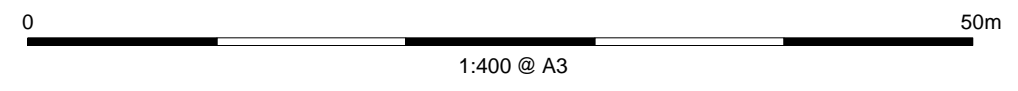
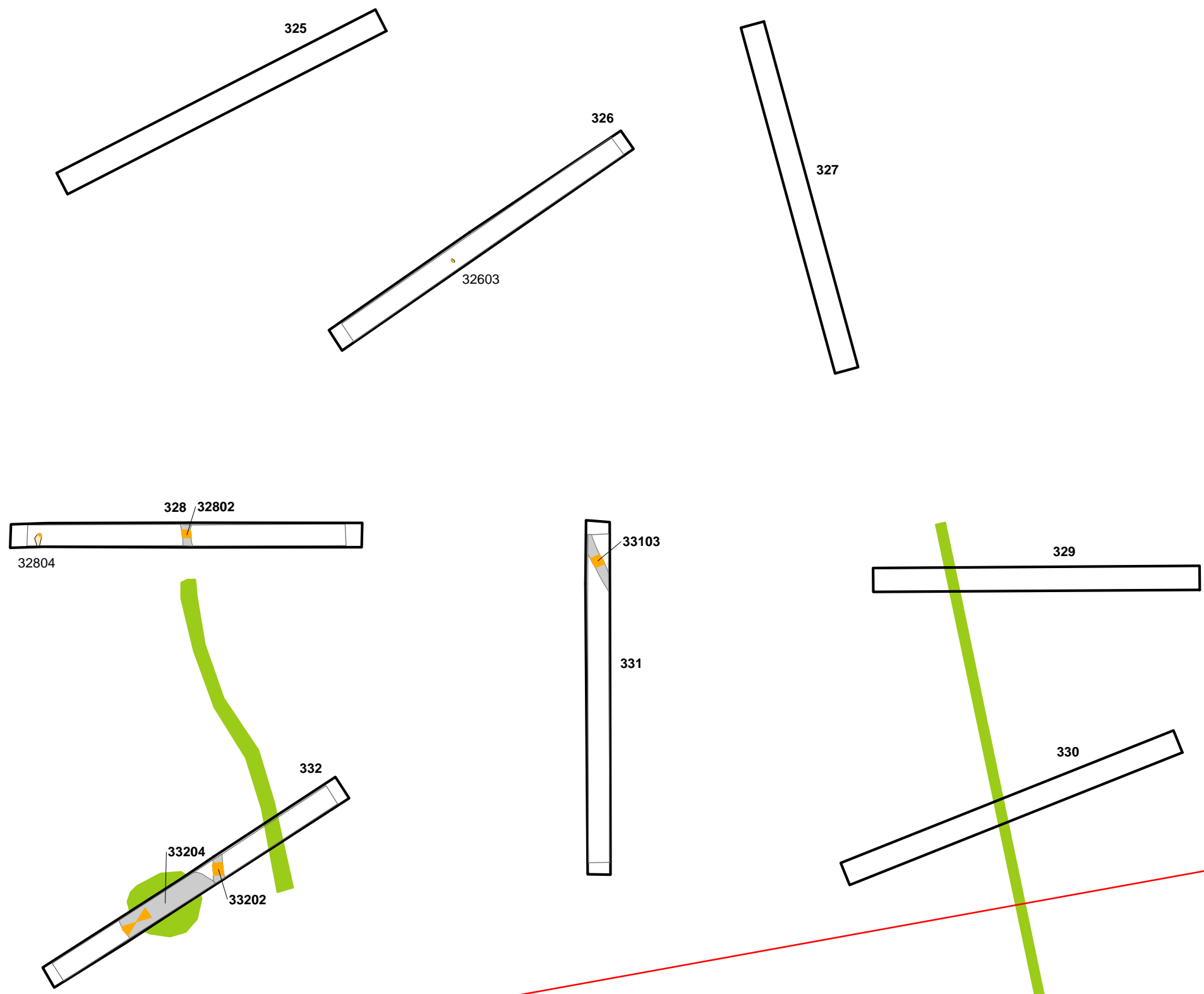
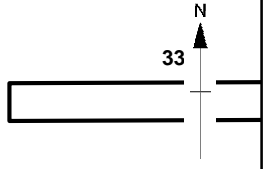

Figure 48: Plan of Trenches 326 and 328-332

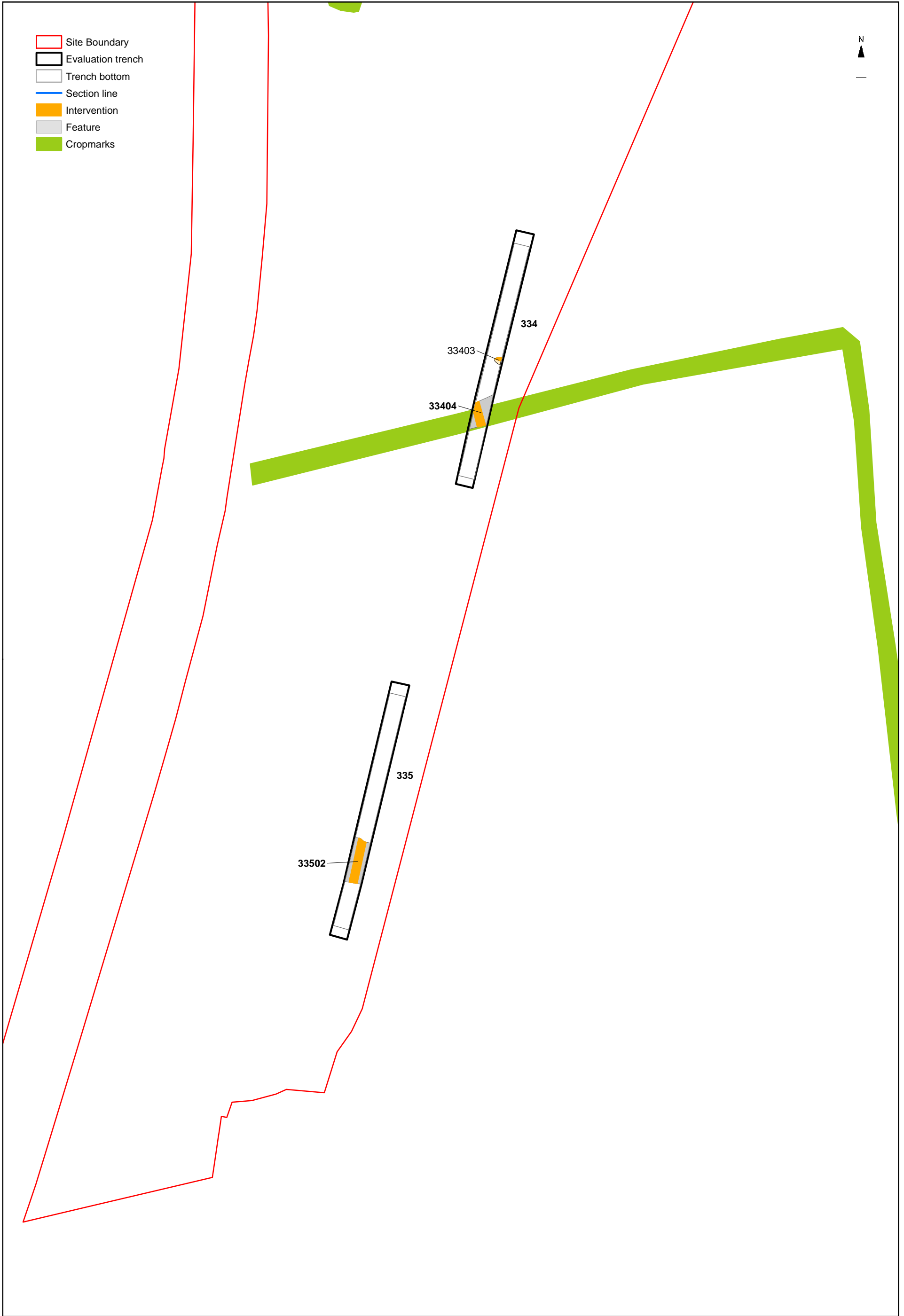
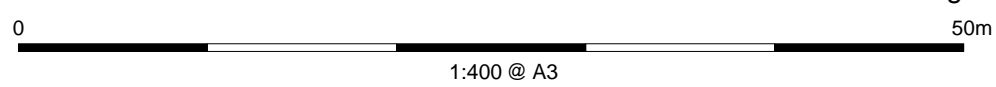

Figure 49: Plan of Trenches 334 and 335



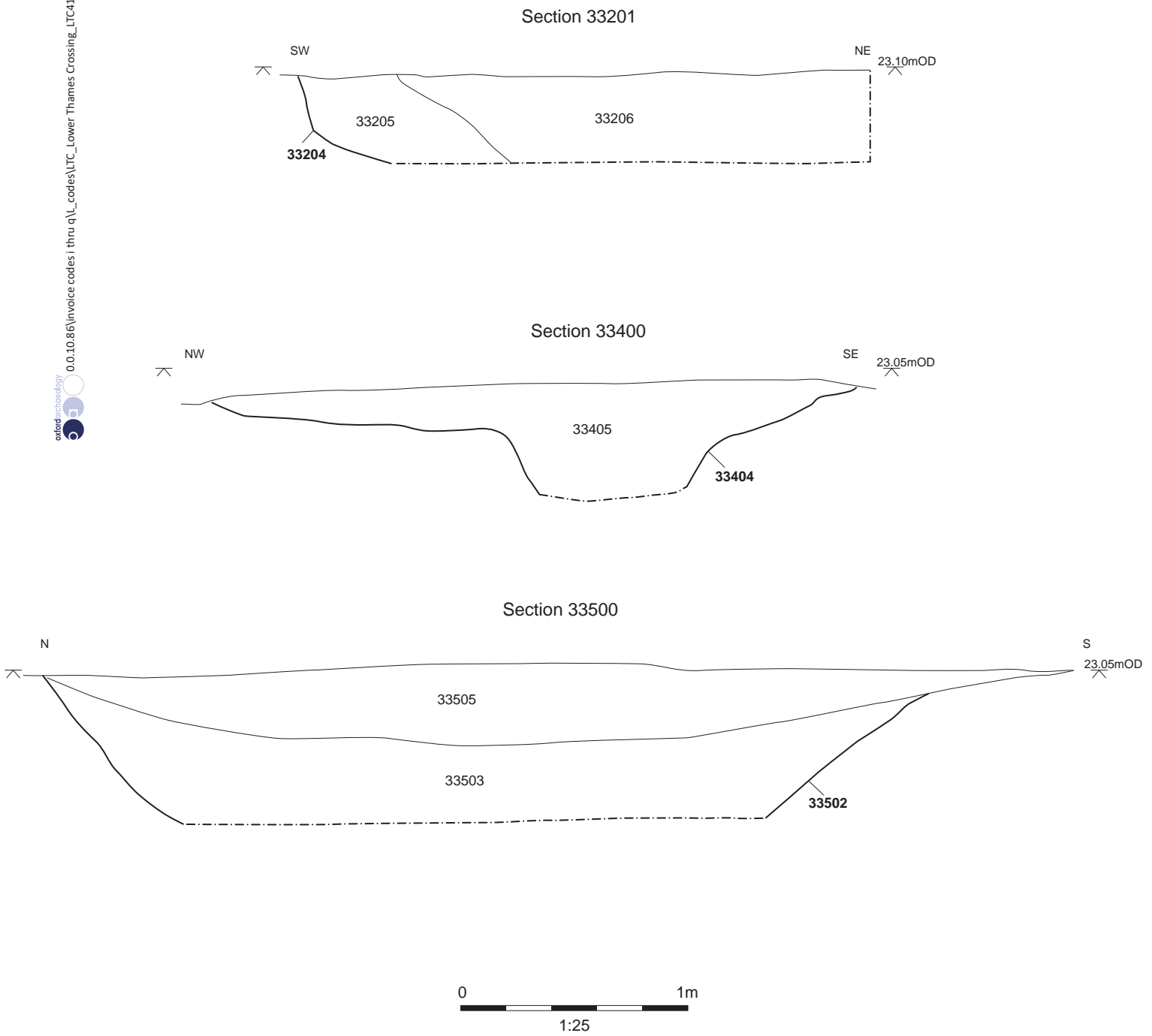

Figure 50: Sections (Trenches 332, 334 and 335)

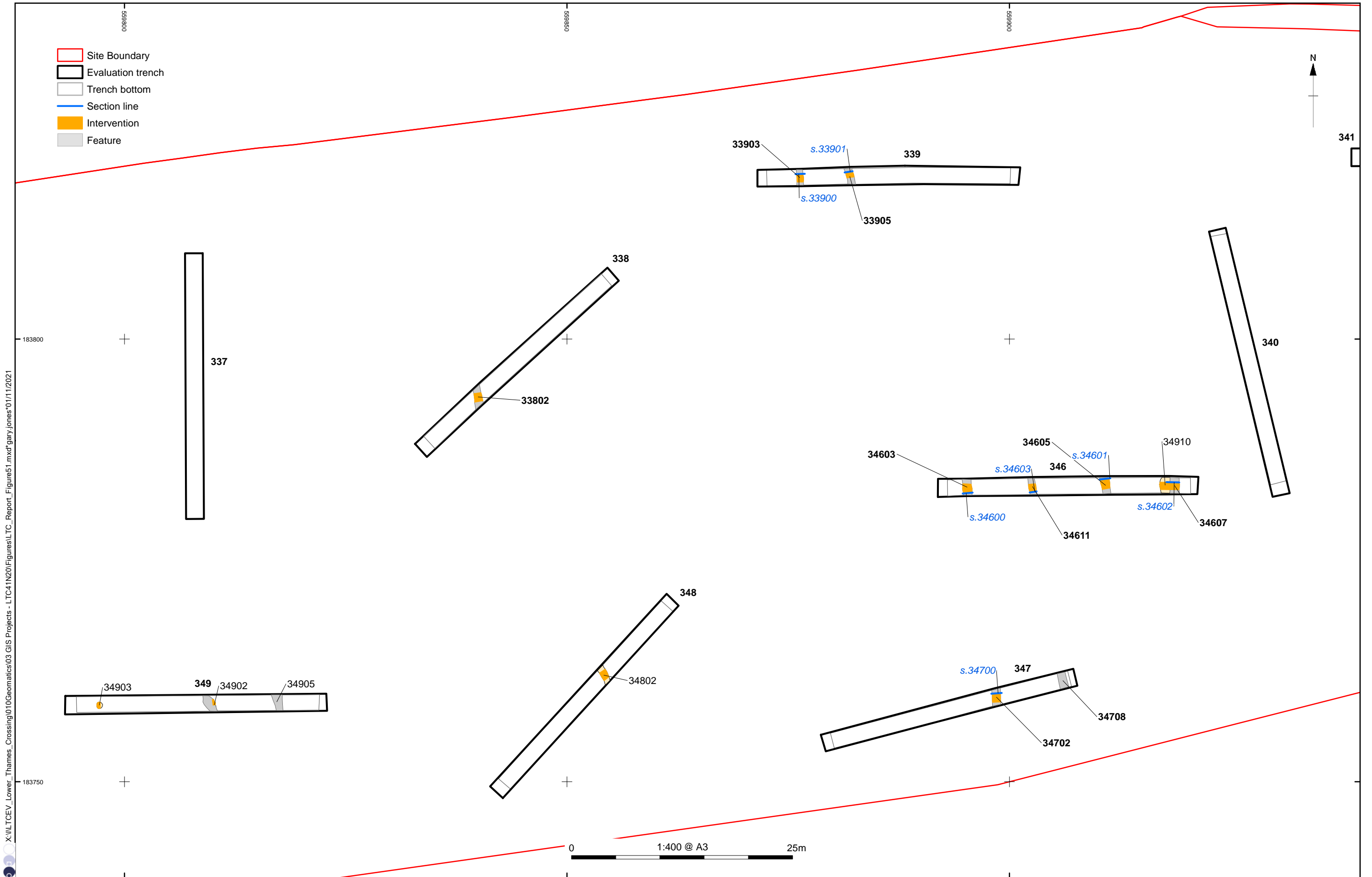

Figure 51: Plan of Trenches 338, 339 and 346-349

X:\ILTCEV_Lower_Thames_Crossing\010Geomatics\03 GIS Projects - LTC41N20\Figures\LC_Report_Figures\1.mxd\gary.jones\01/11/2021

X:\ILT\TCEV_Lower_Thames_Crossing\010\Geomatics\03 GIS Projects - LTC41N20\Figures\LTC_Report_Figure52.mxd\aldan.farman\31082021

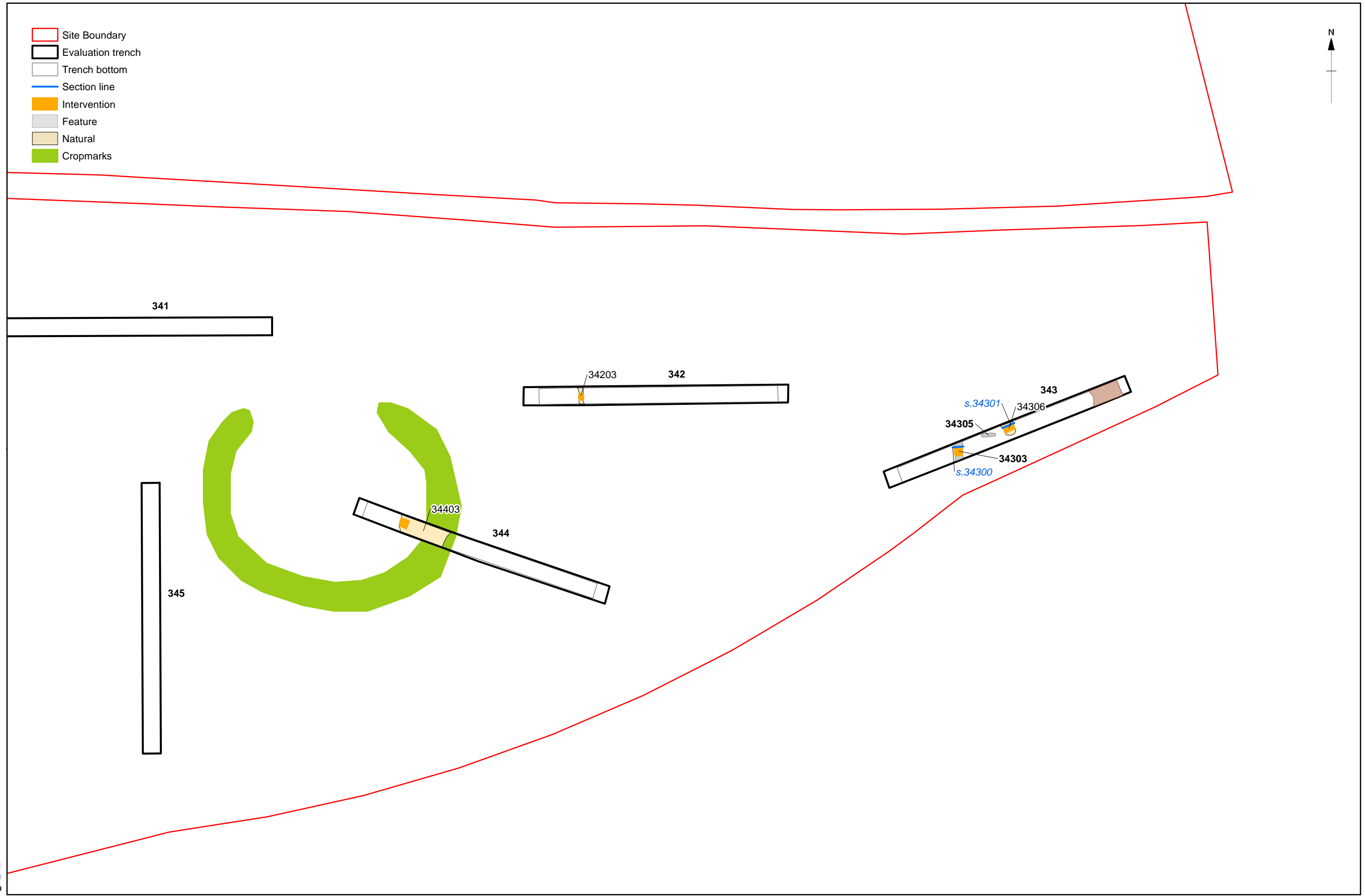

Figure 52: Plan of Trenches 342-344



Plate 1: West facing Section 6800 through kiln structure 6808



Plate 2: West facing section 7200 through pit 7202



Plate 3: South-east facing section 7700 through layer 7704



Plate 4: South facing section 8400 through boundary ditch 8402



Plate 5: North facing section 10701 through boundary ditch 10704



Plate 6: South facing section 13500 through pit 13503



Plate 7: North-east facing section 14900 through ditches 14902 and 14905



Plate 8: NNW facing section 20600 through ditch 20604



Plate 9: North-west facing section 22400 through ditch 22403

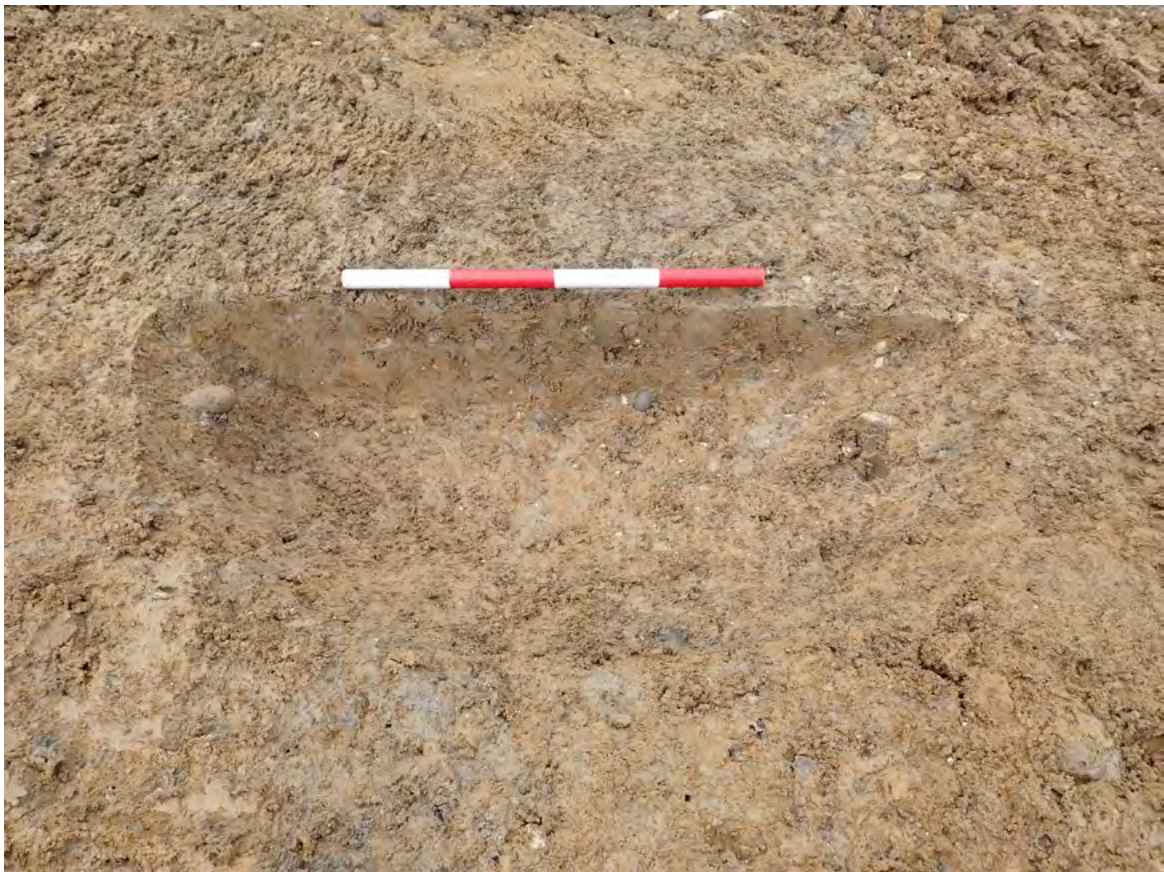

Plate 10: North facing section 24000 through pit 24003



Plate 11: South facing section 24600 through pit 24603



Plate 12: North facing section 25400 through ditch 25403



Plate 13: East facing section 26701 through posthole 26706



Plate 14: North-east facing section 27601 through ring gully 27607



Plate 15: North-west facing section 28500 through ring ditch 28503



Plate 16: West facing view of Trench 208

COVER SHEET

Title:	Archaeological Evaluation Report for Trial Trenching of Land Parcels 43, 45A-E and 46 Mar Dyke Valley, between South Ockendon and Orsett				
Project Name:	Lower Thames Crossing Enabling Works				
Ref No:	HE540039-BAL-GEN-GEN-REP-HER-00062				
Revision No:	P01				
Review Date:	14/01/2022				
Status:	S2 – For Information				
No. of Pages	321				
Rev	Date of Issue	Revision Status	Originator	Checker	Approver
P01	14/01/2022	S2	Conal Mundy	Jack Fletcher	Emily Erswell



Lower Thames Crossing

Archaeological Evaluation Report for Trial Trenching of
Land Parcels 43, 45A-E and 46
Mar Dyke Valley, between South Ockendon and Orsett

Document Number: HE540039-BAL-GEN-GEN-REP-HER-00062

January 2022



Revision	Production Date	Prepared by	Checked by	Approved for release by	Sections revised
1.1	January 2022	Mark Hewson Senior Publications Officer Cotswold Archaeology Tim Allen Senior Project Manager Oxford Archaeology	Steve Lawrence Senior Project Manager Oxford Archaeology		

This Evaluation Report has been prepared for Highways England in accordance with the terms and conditions of appointment stated in the Lower Thames Crossing (LTC) Technical Partner Contract. LTC cannot accept any responsibility for any use of or reliance on the contents of this document by any third party.

Contents

Section	Page
Summary	11
Acknowledgements	12
1 Introduction	13
1.1 Project details and scope of work	13
1.2 Location, topography and geology	14
1.3 Previous investigations	14
1.4 Archaeological and historical background.....	14
2 Project Aims	22
2.1 General aims	22
2.2 Specific objectives	23
3 Methodology	24
3.1 Constraints.....	24
3.2 Methodology for the evaluation	24
4 Results	26
4.1 Introduction and presentation of results	26
4.2 General soils and ground conditions.....	26
4.3 General distribution of archaeological deposits	27
4.4 Trenches 306, 311, 328, 330 and 336 (Figs 3 and 14-17).....	28
4.5 Trenches 341, 343, 346, 349, 351, 352, 354 and 359 (Figs 4 and 18-20)	29
4.6 Trenches 362, 369 and 370 (Figs 4-5, 21 and 23).....	31
4.7 Trenches 372 and 383 (Figs 5, 22 and 23).....	32
4.8 Trenches 374 and 375 (Figs 4-5, 24 and 26).....	32
4.9 Trenches 376 and 378 (Figs 4-5, 25 and 26).....	33
4.10 Trenches 379 and 382 (Figs 4-5, 27 and 32).....	34
4.11 Trenches 388, 389, 390 and 392 (Figs 4-5, 28 and 32).....	35
4.12 Trenches 365, 409, 419 and 427 (Figs 6-7, 23 and 29-32).....	36
4.13 Trenches 441, 442, 443 and 445 (Figs 8, 33 and 35).....	37
4.14 Trenches 448, 450 and 451 (Figs 8, 34 and 35).....	37
4.15 Trench 452, 453, 454 and 455 (Figs 9 and 36-37).....	38
4.16 Trenches 457, 459, 460, 461, 462, 463 and 464 (Figs 10, 38-39 and 41)	41
4.17 Trench 466 (Figs 10-11, 40 and 41)	43
4.18 Trench 482 (Figs 10-11, 42 and 46)	43
4.19 Trenches 487, 488, 492, 493, 494, 502 and 505 (Figs 11 and 43-47)	44
4.20 Trenches 514, 520, 521, 523, 525 and 528 (Figs 12-13, 48, 49 and 51)	46
4.21 Trench 534 (Figs 12 and 50-51)	48
4.22 Finds summary	48
4.23 Environmental summary	49
5 Discussion	50
5.1 Reliability of field investigation	50

5.2	Interpretation.....	51
5.3	Evaluation objectives and results.....	54
Appendix A	Trench Tables	58
Appendix B	Finds Reports	170
Appendix C	Environmental Reports	183
Appendix D	Geoarchaeology Assessment	191
Appendix E	References	210
Appendix F	Abbreviations and Glossary	214
Appendix G	Site Summary.....	215

Figures

Figure 1: Map showing the location of Land Parcels 43, 45A-E and 46

Figure 2: Plan of trenches, cropmark features and geoarchaeological transect locations

Figure 3: Detailed overview of Land Parcel 45E with cropmarks, historic mapping and archaeological features

Figure 4: Detailed overview of north half of Land Parcel 45D with cropmarks, historic mapping and archaeological features

Figure 5: Detailed overview of south half of Land Parcel 45D with cropmarks, historic mapping and archaeological features

Figure 6: Detailed overview of north half of Land Parcel 45C with cropmarks, historic mapping and archaeological features

Figure 7: Detailed overview of south half of Land Parcel 45C with cropmarks, historic mapping and archaeological features

Figure 8: Detailed overview of north half of Land Parcel 45B with cropmarks, historic mapping and archaeological features

Figure 9: Detailed overview of south half of Land Parcel 45B with cropmarks, historic mapping and archaeological features

Figure 10: Detailed overview of north half of Land Parcel 46 with cropmarks, historic mapping and archaeological features

Figure 11: Detailed overview of south half of Land Parcel 46 with cropmarks, historic mapping and archaeological features

Figure 12: Detailed overview of east half of Land Parcel 43 with cropmarks, historic mapping and archaeological features

Figure 13: Detailed overview of west half of Land Parcel 43 with cropmarks, historic mapping and archaeological features

Figure 14: Plan of Trenches 306 and 311

Figure 15: Plan of Trenches 328 and 330

Figure 16: Plan of Trench 336

Figure 17: Sections (Trenches 306, 311, 328, 330 and 336)

Figure 18: Plan of Trenches 341-343, 349-351 and 357-359

Figure 19: Plan of Trenches 344-346 and 352-354

Figure 20: Sections (Trenches 341, 343, 346, 349, 351, 352, 354 and 359)

Figure 21: Plan of Trenches 361-362 and 369-370

Figure 22: Plan of Trenches 371-372 and 383-384

Figure 23: Sections (Trenches 362, 365, 369, 370 and 372)

Figure 24: Plan of Trenches 374-375

Figure 25: Plan of Trenches 376 and 378

Figure 26: Sections (Trenches 374, 375, 376 and 378)

Figure 27: Plan of Trenches 379-380 and 382

Figure 28: Plan of Trenches 388-390 and 392

Figure 29: Plan of Trenches 365, 406 and 408-409

Figure 30: Plan of Trench 419

Figure 31: Plan of Trench 427

Figure 32: Sections (Trenches 379, 382, 388, 389, 390, 392, 409, 419 and 427)

Figure 33: Plan of Trenches 441-445

Figure 34: Plan of Trenches 448, 450 and 451

Figure 35: Sections (Trenches 442, 443, 448, 450 and 451)

Figure 36: Plan of Trenches 452-455

Figure 37: Sections (Trenches 452, 454 and 455)

Figure 38: Plan of Trenches 457 and 459-460

Figure 39: Plan of Trenches 461-464

Figure 40: Plan of Trench 466

Figure 41: Sections (Trenches 457, 460, 461, 462, 464 and 466)

Figure 42: Plan of Trenches 482

Figure 43: Plan of Trenches 487-488 and 492-494
Figure 44: Plan of Trenches 489 and 502
Figure 45: Plan of Trench 505
Figure 46: Sections (Trenches 482, 487 and 488)
Figure 47: Sections (Trenches 489, 492, 493, 494, 502 and 505)
Figure 48: Plan of Trenches 513-514, 519-521 and 526-527
Figure 49: Plan of Trenches 516, 523-525 and 528-530
Figure 50: Plan of Trench 534
Figure 51: Sections (Trenches 514, 516, 519, 520, 521, 526, 528 and 534)
Figure 52: Geoarchaeological transect 1: Boreholes WS101-WS118
Figure 53: Geoarchaeological transect 6: Trenches 534, 541, 392, 335 and 338
Figure 54: Geoarchaeological transect 7: Trenches 495, 363, 366, 368, 370, 406, 400 and 397
Figure 55: Geoarchaeological transect 8: Trenches 346, 353, 361, 362, 370, 378, 381, 411, 431, 440
Figure 56: Geoarchaeological transect 9: Trenches 406, 408, 421, 423, 427, 430, 434, 433, 438, 443, and 449
Figure 57: Geoarchaeological transect 10: Trenches 394, 397, 403, 405, 435, 445, 450, 452, 455, 454 and 456
Figure 58: Geoarchaeological transect 11: Trenches 431, 433, 434 and 435

Plates

Plate 1: Ditch 30609 looking north-west
Plate 2: Ditch 31112 looking south
Plate 3: Ditch 32804/32808 looking north-west
Plate 4: Ditch 32802 looking east
Plate 5: Ditch 33002 looking west
Plate 6: Gully 33006 looking north-west
Plate 7: Postholes 31109, 31110, 31105 and 31106 looking east
Plate 8: Postholes 31109 and 31106 looking north
Plate 9: Postholes 31110 and 31105 looking north
Plate 10: Postholes 31109, 31110, 31105 and 31106 looking west

Plate 11: Ditch 34107 looking north
Plate 12: Ditch 34306 looking north
Plate 13: Ditch 34603 looking north
Plate 14: Gully 35202 looking west
Plate 15: Gully 36204 looking north-west
Plate 16: Ditch 35404 looking north
Plate 17: Ditches 35902 and 35904 looking north
Plate 18: Ditch 34302 looking north-east
Plate 19: Ditch 35103 looking east
Plate 20: Quarry/pond 34105 looking south
Plate 21: Ditch 37402 looking west
Plate 22: Ditches 37511, 37509 and 37506
Plate 23: Ditch 37502 looking north
Plate 24: Ditch 37606 looking east
Plate 25: Pit 37808 looking north
Plate 26: Ditch 37903 looking east
Plate 27: Ditch 38202 looking north-west
Plate 28: Ditch 38206 looking north-west
Plate 29: Ditch 39003 looking north
Plate 30: Pit 39011 and posthole 39013 looking south
Plate 31: Pit 40903 looking west
Plate 32: Pit 40903 overhead
Plate 33: Pit 42703 looking east
Plate 34: Ditch 44203 looking east
Plate 35: Ditch 44803 looking south
Plate 36: Ditch 45003 looking east
Plate 37: Ditch 45008 looking east
Plate 38: Ditch 45202 looking south-east
Plate 39: Ditch 45207 looking south-east
Plate 40: Ditch 45209 looking north-west

- Plate 41: Posthole 45205 looking east
- Plate 42: Posthole 45402 looking north-west
- Plate 43: Posthole 45404 looking north-west
- Plate 44: Posthole 45412 looking north-west
- Plate 45: Posthole 45406 looking north-east
- Plate 46: Ditches 45511 and 45506 looking north-east
- Plate 47: Tree throw 45513 looking north-east
- Plate 48: Ditch 45703 looking north-west
- Plate 49: Ditch 45705 looking north-west
- Plate 50: Ditch 46106 looking north
- Plate 51: Ditch 46203 looking south
- Plate 52: Hearth 46003 looking south-west
- Plate 53: Pit 46005 looking south
- Plate 54: Ditch 46007 looking north-west
- Plate 55: Ditches 46007/46015 and 46013 looking south
- Plate 56: Ditches 46013 and 46015 looking east
- Plate 57: Occupation deposit 46019/46020 looking NNE
- Plate 58: Ditch terminus 46602 looking east
- Plate 59: Ditch 48210 looking north
- Plate 60: Ditches 48703 and 48705 looking south
- Plate 61: Ditch terminus 49305 looking north-east
- Plate 62: Possible hearth or tree throw 51603 looking west
- Plate 63: Ditch 52602 looking west
- Plate 64: Ditch 51904 looking north-east
- Plate 65: Ditch 52103 looking north-east
- Plate 66: Transect 6, Trench 338, Section 33800 – Sedimentary sequence within dry valley base on western slopes of Mar Dyke valley
- Plate 67: Transect 7, Trench 397, Section 39700 – Intercalated alluvium and stabilisation horizons overlying leached horizon on Mar Dyke floodplain to the eastern side of Land Parcel 45C

- Plate 68: Transect 7, Trench 400, Section 40000 - Intercalated alluvium and stabilisation horizons overlying leached horizon on Mar Dyke floodplain. Section location is within faint palaeochannel identified on LiDAR imagery
- Plate 69: Transect 8, Trench 362, Section 36200 – Head and London Clay deposits occurring throughout northern Mar Dyke valley promontory
- Plate 70: Transect 8, Trench 431, Section 43100 – Intercalated alluvium and stabilisation horizons overlying leached horizon on Mar Dyke floodplain. Section location is within faint palaeochannel identified on LiDAR imagery
- Plate 71: Transects 9 and 11, Trench 433, Section 43300 – Mar Dyke alluvial deposits overlying potential channel deposits
- Plate 72: Transects 9 and 11, Trench 434, Section 43400 - Mar Dyke alluvial deposits overlying potential channel deposits
- Plate 73: Transect 9, Trench 406, Section 40600 – Sedimentary sequence occurring on floodplain margins, containing leached horizons
- Plate 74: Transects 10 and 11, Trench 435, Section 43501 – Intercalated alluvium and stabilisation horizons overlying leached horizon on Mar Dyke floodplain
- Plate 75: Transect 10, Trench 454, Section 45406 – Head and London Clay deposits on southern Mar Dyke valley promontory, truncated by ditch 45416
- Plate 76: Transect 10, Trench 445, Section 44500 - Intercalated alluvium and stabilisation horizons overlying leached horizon on Mar Dyke floodplain on Land Parcel 45B. Lower alluvium contained EIA pottery
- Plate 77: Transect 11, Trench 435, Section 43501 – Monoliths and OSL samples from the upper 1m of alluvium and ephemeral stabilisation horizons overlying leached horizon on Mar Dyke floodplain on Land Parcel 45B. Lower alluvium contained EIA pottery

Tables

Table 1: Summary and quantification of the pottery by context

Table 2. Pottery quantification by fabric

Table 3: Pottery catalogue

Table 4. Pottery by context with suggested spot dates

Table 5: Summary of ceramic building material by context

Table 6: Catalogue of fired clay

Table 7: Breakdown of flint assemblage by type

Table 8: Summary of metalwork by context

Table 9: Assessment of CPR flots

Table 10: Burnt bone - Osteological summary

Table 11: Burnt bone - Summary of fragmentation

Table 12: Burnt human bone - Summary of identified elements

Table 13: Summary of animal bones by context

Table 14: Number of identifiable species (NISP) by period

Table 15: Summary of borehole locations

Table 16: Summary of geoarchaeology section locations

Table 17: Summary of sampled sedimentary sequences

Summary

Oxford Cotswold Archaeology was commissioned by Balfour Beatty to undertake a trial trench evaluation of Land Parcels 43, 45A-E and 46 of the Lower Thames Crossing Pre-Enabling Works. Land Parcels 43, 45A-E and 46 are located c 1km to the south-east of the village of North Ockendon and c 2.5km north-east of South Ockendon in the historic parish of South Ockendon in Thurrock unitary authority, within the county of Essex (broadly centred on NGR 561994 183659). The evaluation comprised the excavation of 240 trenches and was completed between 9th September to 29th October 2021.

Archaeological features were reasonably well defined against the underlying London Clay and Head deposits, especially since the majority cut through the Head deposits rather than directly through the London Clay. Several natural features were also excavated to clarify whether they were of geological or archaeological origin. Wet weather was increasingly a problem towards the end of the evaluation, but had a limited impact since archaeological remains were identified during initial stripping and were predominantly evaluated prior to flooding. A total of 67 trenches revealed archaeological features.

Alluvial deposits were widespread across the floodplain and floodplain margins in Land Parcels 45B and 45C, and in one trench on the edge of 45D. Archaeological remains were found beneath alluvium in Land Parcels 45B and in 45D. In Land Parcel 45C Iron Age finds came from an alluvial layer, possibly indicating surface activity.

With the exception of a very small residual flint assemblage no activity of earlier prehistoric date was recorded within the site. A pit containing much of a single middle Bronze Age vessel, struck flints, charcoal and charred grain was found in Land Parcel 45C. This was the only feature of this date identified.

A focus of late Bronze Age or early Iron Age activity was found in Land Parcel 46, centred on a ditch containing pottery, a flint core and flakes, part of a cremated human burial, fired clay and charcoal, with a possible hearth pit adjacent, both cut into a possible occupation layer. Similar finds were also recovered from adjacent trenches.

Several small areas of Iron Age activity were identified across the site, all at the edges of the evaluated area, so possibly adjacent to more substantial activity areas. Two areas, one in Land Parcel 45B, the other in 45E, contained groups of postholes and other features associated with Iron Age pottery and fired clay objects suggesting either domestic or agricultural structures. Others in Land Parcels 43, 45B and 45D had finds predominantly in parallel ditches, possibly indicating paddocks or cultivation trenches.

In the late Iron Age and Roman periods finds came predominantly from U-profiled cultivation trenches that occurred in patchy concentrations across the valley sides, though not all contained pottery. These are similar to others found on the southern slope of the Mar Dyke valley and in a tributary valley to the north-west, and represent a widespread local type in the Roman cultivation of the slopes of the Mar Dyke valley

A small but substantial cropmark rectangular enclosure in Land Parcel 45D was confirmed as medieval, the pottery assemblage indicating use from at least the 13th century to the 15th century. Post-medieval field boundaries corresponding with those depicted on historic maps and evident as cropmarks were recorded were identified in Land Parcels 43 and 45B.

Acknowledgements

Oxford Cotswold Archaeology would like to thank the client, Balfour Beatty, for commissioning this project and managing the site safety and attendances. Thanks are also extended to the Historic Environment Consultants (Richard Havis and Katie Lee-Smith) of Place Services for Essex County Council advising the Borough of Thurrock, for monitoring and providing advice throughout the project.

The project was managed for Oxford Cotswold Archaeology by Steve Lawrence. The fieldwork was directed by Mark Dodd, who was supported by Joan Roig, Eilidh Barr, Edmund Cole, Jack Easen, Nigel Byram and Tim Sperring, with Edmund Cole, Dan Firth, Adrienne Morris, Charlotte Brown, Harry Mixer, Mar Roige Oliver, Stephen Foster, Yeraí Francisco-Benet, Tom Bruce, Benjamin Slader, Rose Britton, Kamil Prus, Kerree Foster, Mia Long, Tom Hayes, Tara Schug, Christof Heistermann, Ashley Joynes, Harlie Mason, Anna Lound, Benjamin Massey, Chloe Groves, Chris Griffiths, Christopher Smallwood, Danika Beale, Eliza Greenwell, Gemma Deaney, Georgina Matthews, Graeme Botham, Heloise Meziani, Holly Wright, Joe Smith, Josie Francis, Marionna Sandin Catacora, Mel Harvell, Richard Spencer, Sian Bramble, Ben Slader and Tomasz Neyman. Site survey was undertaken by Caroline Souday and Elodie Powell and digitising was carried out by Gary Jones, Benjamin Brown and Simon Batsman. Thanks are also extended to the teams of Oxford Cotswold Archaeology staff that cleaned and packaged the finds under the management of Leigh Allen and Geraldine Crann, processed the environmental remains under the management of Rebecca Nicholson, and prepared the archive under the management of Nicola Scott.

1 Introduction

1.1 Project details and scope of work

- 1.1.1 The Lower Thames Crossing Project is located between the A2 in Kent and the M25 in the London Borough of Havering. It will run underneath the River Thames through a tunnel and emerge on the northern side of the river at East Tilbury. From the North Portal the road will run to the M25 at Junction 29 via the A13 and pass between North and South Ockendon. The development of the project is managed by LTC, a partnership between Highways England and a consultancy joint venture set up to oversee the scheme.
- 1.1.2 A programme of archaeological trial trenching began in the Essex part of the scheme in November 2019. A scheme-wide specification for trial trenching was written by LTC (Highways England 2018), and in July 2019 LTC commissioned Balfour Beatty to deliver the pre-Enabling Works. Balfour Beatty appointed Oxford Archaeology (hereafter OA) to prepare a project-wide written scheme of investigation (WSI) for the scheme, which (at the request of the key archaeological stakeholders) is divided into two parts, one for the Kent section, the other for Essex and Havering (Oxford Archaeology 2019a, 2019b).
- 1.1.3 Following completion of the project-wide WSIs, OA was also instructed to prepare a series of site-specific or group-site specific WSIs for approval by the key archaeological stakeholders in advance of trial trenching to inform the Development Consent Order (DCO). A detailed WSI (WSI P) was created for Land Parcels 43, 45 – 48 and 120 – 125 prior to the trial trenching (Oxford Archaeology 2021). WSI P details the archaeological background and potential within these Land Parcels. It also indicated the archaeological aims and objectives appropriate to the investigation of these Land Parcels by trenching and set out the methodology. This WSI was approved by Richard Havis, Principal Historic Environment Consultant for Place Services, Essex County Council, prior to the start of the fieldwork. Oxford Cotswold Archaeology was commissioned as Balfour Beatty's archaeological contractor to undertake the evaluation in accordance with the approved WSI and local and national planning policies. This trial trench evaluation report provides the results of the works in Land Parcels 43, 45A-E and 46 specifically.
- 1.1.4 The fieldwork was completed between the 9th September and the 29th October 2021. All work adhered to the *Management of Research Projects in the Historic Environment: The MoRPHE Project Managers' Guide* (Historic England 2015a) and the *Code of conduct* of the Chartered Institute for Archaeologists (CIfA) (CIfA 2014a, revised 2019). It also followed the *Standard and guidance for archaeological evaluation* and the *Standard and guidance for the creation, compilation, transfer and deposition of archaeological archives* (CIfA 2014b updated 2020; CIFA 2014c updated 2020).
- 1.1.5 The work was monitored by Richard Havis and Katie Lee-Smith, Place Services, ECC advising the Borough of Thurrock.

1.2 Location, topography and geology

- 1.2.1 Land Parcels 43, 45A-E and 46 are located c 1km to the south-east of the village of North Ockendon and c 2.5km north-east of South Ockendon (Fig. 1) in the historic parish of South Ockendon in Thurrock unitary authority within the county of Essex (NGR 561994 183659). Land Parcel 43 is roughly rectangular in shape and 45A, triangular; the other land parcels, 45B-E and 46, are irregularly shaped. Together they cover an area of c 104.5ha. These land parcels are bounded to the north, east and south by agricultural fields and to the west by a mix of agricultural land and rough grassland. Together, hereafter they are referred to as the 'site'.
- 1.2.2 The bedrock geology of the site is London Clay Formation (clay, silt and sand). The superficial geology across much of the site is alluvium comprising clay, silt, sand and gravel, associated with the Mar Dyke river. Elsewhere, specifically the western end of Land Parcel 46 and in Land Parcel 43 there is Head Clay (clay, silt, sand and gravel) located on the lower north-west slope of the Mar Dyke valley. The whole site comprises agricultural land, predominantly under arable cultivation.
- 1.2.3 The site is predominantly situated at the base of the Mar Dyke valley; the river flowing along the eastern boundaries of Land Parcels 45A-C and further to the east of Land Parcels 45D, 43 and 46, which lie on the slightly rising ground of its WNW valley slope. Land Parcel 45D lies c 400m to the west, Land Parcel 46, c 650m to the west and Land Parcel 43 c 1.5km to the west of the modern water course. The lowest point of the site is situated almost in valley bottom at a height of c 4.0m above Ordnance Datum (aOD), the ground sloping upward to the WNW, to a high point at c 21m aOD.

1.3 Previous investigations

- 1.3.1 No known below-ground archaeological investigations have been undertaken within the site specifically. However, in 1993-94, Wessex Archaeology conducted several watching briefs in the vicinity of the wider site as part of the Horndon to Barking Natural Gas Transmission Pipeline investigations. One of these watching briefs included an area within the southern boundary of the Land Parcel 43, where a SW-NE aligned ditch was found, which contained Bronze Age pottery (Oxford Archaeology 2021).
- 1.3.2 In the mid-19th century a Roman settlement and a possible Roman cemetery was excavated by labourers in the vicinity of the site, though there is some confusion about its location. The HER places this excavation to the north-east of the site, whilst PastScape places it further to the west (Oxford Archaeology 2021).

1.4 Archaeological and historical background

- 1.4.1 The chronological summary of known archaeology given below is taken from WSI P (Oxford Archaeology 2021). Much of the site is situated at the foot of the Mar Dyke valley and part also on its north-west slope. Holocene prehistoric features, findspots and cropmarks have been identified further to the south on the southern valley slopes. The cropmarks that have been recorded within and

around the site are those mapped by the Aerial Investigation and Mapping report (Place Services 2019). These cropmarks are shown on Figure 2.

- 1.4.2 **Palaeolithic.** No Palaeolithic finds have been recorded within 1km of the site. A Palaeolithic handaxe was found on the ground surface c 1km west of Land Parcel 45B at South Ockendon Hall. The find was discovered in 1978 when a windmill on the south side of the moat was demolished. This object may have been disturbed during the excavation of the nearby moat.
- 1.4.3 **Mesolithic.** No known Mesolithic flints have been recorded within the site. During an excavation at the William Edwards School 1km south of the site residual flints of Mesolithic and Neolithic date were recorded.
- 1.4.4 **Neolithic and early Bronze Age.** No certain Neolithic or early Bronze Age features or finds have been recorded within 1km of the site.
- 1.4.5 A cropmark possibly representing a large sub-circular enclosure 45m across and with opposing entrances is located c 250m west of the Land Parcel 43, and if archaeological, this might well represent a late Neolithic henge monument. During the Horndon to Barking Gas Pipeline watching brief a shallow pit was recorded just north of this enclosure, which contained cremated bones of a mature/older adult female. There were no finds, but this could date from the later Neolithic or Bronze Age. A smaller cropmark penannular enclosure was also recorded c 200m west of Land Parcel 43, which could conceivably also be of earlier prehistoric origin (Fig. 2).
- 1.4.6 Elsewhere, the cropmarks of two parallel lines with a rounded terminal were identified 0.8km south-west of the site. This feature may have been a long-barrow or long mortuary enclosure of early of middle Neolithic date. A flint arrowhead was also found in the 19th century, c 700m north-west of land Parcel 46; this was only dated as prehistoric but is likely to be of early Bronze Age origin.
- 1.4.7 A ring ditch was also recorded nearly 2km south of the site on the slopes of the Mar Dyke valley. This feature is 32m diameter and may represent the site of a ploughed out Bronze Age barrow.
- 1.4.8 **Later Bronze Age and Iron Age.** A ditch containing late Bronze Age finds was found in the south-west corner of Land Parcel 45E during a watching brief for the Hordon to Barking gas pipeline (OA 2021, fig. 6 OA gazetteer No. 380). This ditch was on a SW-NE alignment and was parallel to, and 40m north of, the existing field boundary. The ditch contained a relatively large quantity of burnt flint and three sherds of flint-gritted pottery, probably of late Bronze Age date. A second ditch on a parallel alignment produced a single sherd of late Bronze Age pottery along with 19th-20th century pottery. These ditches, which follow the downward slope of the topography, may conceivably indicate survival of ancient field systems, or may have cut through late Bronze Age features on the slopes of the Mar Dyke Valley.
- 1.4.9 Two rectilinear cropmark enclosures, one only partially visible, and a system of linear boundaries probably representing a field system have also been identified in Land Parcels 46 and 45D (Fig. 2). Although currently undated, these may be of later prehistoric date, or alternatively may be Roman (see below).

- 1.4.10 The cropmark of a sinuous curving ditch following an irregular course was recorded as part of the aerial mapping survey 250m east of Land Parcel 45C (Fig. 2). This defines the western edge of a promontory and follows the topography of an area of higher ground. This feature can also be seen as an earthwork on LiDAR imagery, and it is therefore possible that a bank and a ditch may be present at this location. Late Iron Age pottery was found nearby on the edge of this promontory during the archaeological monitoring for the Hordon to Barking gas pipeline. It is possible that the bank and ditch are of later prehistoric date and the siting of it may suggest a defensive site. Alternatively, these features may represent a medieval or post-medieval field boundary, although it differs in character to the regular north-south post-medieval field boundaries just to the east.
- 1.4.11 On the southern edge of the Mar Dyke valley the scheduled Orsett cropmark complex (1002134) is located on the gravel terrace c 1.8km south of the site. The main concentration of enclosures, ring ditches (probable prehistoric round house gullies), trackways and field systems are located in the northern part of the monument. Recent evaluation of these has confirmed that the complex is a mixture of later Bronze Age, early, middle and late Iron Age and Roman features. A small probable ring ditch on the west edge of Land Parcel 22 and within this complex produced struck flints of later Bronze Age character, and much of a late Bronze Age vessel was recovered from a pit elsewhere within the complex.
- 1.4.12 In 1979 the southern part of the Orsett (Grey Goose Farm) Cropmark Complex was excavated during alterations to the A13, and several late Bronze Age to early Iron Age features, comprising one large and three small pits, postholes and a gully. These features were mostly located in the A1089 loop junction just north of the A13. The A13 investigations also found that some of the 'pits' were of geological origin, and the recent evaluations have confirmed that most of the discrete cropmarks are geological, although one pit alignment that continues as a ditch appears to be archaeological.
- 1.4.13 Two possible prehistoric cropmark enclosures have been identified east of the Orsett scheduled complex, and the site of a scheduled probable late Bronze Age enclosure (1009287) lies some c 1.5km south-east of the site. To the west of the Orsett Cropmark complex and c 1.3km south-west of the site, an excavation at William Edwards school revealed late Bronze Age and early Iron Age settlement.
- 1.4.14 Bronze Age and Iron Age pottery was recovered from a mound c 1km west of Land Parcel 45B. This mound may have been one of three Roman barrows once present around South Ockendon Hall (Fig. 2). Two sherds of Iron Age pottery were also found during the excavation of the Roman scheduled barrow (1019106) located c 500m south-west of the site. The Roman barrows may have truncated Bronze Age or Iron Age features during their construction.
- 1.4.15 In 1966, 13 Bronze Age weights were found in a clay pit 0.8km south-west of the site. The exact purpose of these weights is unknown, but they may have been roof weights or loom weights. These finds were recorded in the vicinity of the cropmarks of a circular feature. The feature was recorded by the HER as a ploughed-out mound, but it is possible this may have been a domestic Bronze Age enclosure.

- 1.4.16 A number of cropmarks have been recorded on the area of higher ground to the west of the site. These include a trackway and linear features north-west of South Ockendon Hall, a ring ditch and a number of pits c 800m west of the site, ring ditches and a possible mound also to the west of the site and further ring ditches and rectilinear features to the south-west and west of the site. It is likely that some of these features are later prehistoric or Roman in date.
- 1.4.17 **The Roman period.** A scheduled burial mound (1019106) lies c 500m south of Land Parcel 43 and c 1km west of Land Parcel 45B on the high ground of the terrace edge on the western side of the Mar Dyke river valley, close to South Ockendon Hall (Fig. 2). In 1957 a trench through this barrow found 17 sherds of Roman pottery, although the central burial was not disturbed. This barrow may have been one of three spaced a similar distance apart. A second barrow was located c 400m south of the scheduled barrow (1019106), and was excavated prior to removal, the finds being dated to the late second century AD. A third barrow is also documented, though it was the first to be destroyed and its exact location is now unknown. An east-west trackway and other linear features that may be Roman in date were identified north of South Ockendon Hall by the aerial mapping survey (Fig. 2).
- 1.4.18 A possible Roman cemetery was excavated somewhere to the north of the site in the 19th century but the exact location of this discovery is unknown, as noted above. The records suggest that in 1858 farm laborers found Roman pottery, animal bones and charcoal within shallow pits of black earth 3-12m diameter wide in a field within the Mar Dyke valley. This site extended for 2.4 hectares. A number of these pits contained parts of vessels and were located equidistant from one another. The absence of human bones may simply be due to effective cremation of the remains, but the large size of the features described makes it unlikely that these represent cremation burials, though they might indicate pyre sites. On balance, the 'urn sherds' reported may simply represent domestic pottery.
- 1.4.19 One of the fields in which the remains were found in was called 'Ruin Field' and so it is possible that these features may have been part of a settlement that contained one or more buildings. The tithe maps for North Ockendon, South Ockendon, Bulphan and Orsett were checked for references to 'Ruin Field' but none was found.
- 1.4.20 Two rectilinear enclosures have been identified as cropmarks in Land Parcels 46 and 45D (Fig. 2). One had an uncertain relationship with part of a field system to the south and was possibly cut by it. The two parallel ditches aligned WSW-ESE run between two existing field boundaries, so may be post-medieval field boundaries. These enclosures are located on slightly higher ground just above the floodplain. Given their morphology, and their proximity to the possible Roman settlement and/or cemetery, these enclosures may be of Roman (or later prehistoric) date.
- 1.4.21 The Orsett cropmark complex (1002134) located c 1.8km south of the site includes evidence for Roman activity, and a cropmark site to the west at Stifford Clays-Primrose Island and c 2km south-west of the site was excavated in the 1960s and 1970s and revealed a farmstead that was in use from the late Iron Age to the late Roman period with enclosures, ditches, pits, cremations and a corn drying oven. Another Roman enclosure site was also

identified close to the Orsett cropmark complex, on the edge of the river terrace, and c 2km south-east of the site. Roman finds have also been recorded on the terrace. These sites are aligned along the north edge of the gravel terrace and may well have been linked by tracks or a road to Roman settlements around Orsett Cock further east, close to a Roman road.

- 1.4.22 Roman finds have been recorded to the south-west and north-east of the site. These include a coin of Marcus Aurelius (AD 161-180), sherds of Roman pottery of mid-1st to mid-2nd century AD date found whilst stripping the topsoil during an excavation at South Ockendon Hospital and other Roman pottery.
- 1.4.23 During construction of the Epping-Horndon Gas Pipeline Roman pottery was found 1.5km to the north-east of Land Parcel 46.
- 1.4.24 **The medieval period.** No Saxon features or finds have been recorded within the site, and only limited evidence of Saxon activity has been found in the area surrounding it.
- 1.4.25 A dense pattern of pits of varying size and shape are dispersed across the Orsett Cropmark Complex located c 1.8km south of the site (1002134). The pits that appear elongated in shape are thought likely to represent Saxon grubenhouse (sunken-featured buildings). However, excavations directly to the south of the monument and 1.5km south of the site indicated that features identified as pits by cropmark interpretation were primarily of natural origin. Saxon artefacts were, however, recorded in some features. A late Saxon baked clay loom-weight was recovered from one of the features.
- 1.4.26 Documentary evidence suggests that this area was occupied during the Saxon period. During the late Saxon period the site and its surroundings was very likely part of the manorial estate of North and South Ockendon and also the manor of Orsett. The Domesday survey notes that North and South Ockendon was very large for the period with 90 households. Orsett was also large with 61 householders. These three settlements included entries for plough teams, pigs and sheep indicating a mixed agrarian economy. The division between these manors may have later formed the later medieval parish boundaries. The division boundary between the parishes of South Ockendon and Orsett is the Mar Dyke river. The division between South Ockendon and North Ockendon is more arbitrary and runs along field boundaries to the south of Fen Lane and drainage ditches to the north-east of the site.
- 1.4.27 The roads within this part of the scheme appear to have a roughly NNW-SSE and east-west alignment and this could relate to the formation of the parishes or the use of more ancient droveways. The medieval road network is probably much the same as is shown on the OS First edition of 1805 (not illustrated), as the area remained undeveloped into the 20th century. This map shows the north-south road (North Lane) from Puddle Dock to North and South Ockendon (now the B186), which is just west of the site.
- 1.4.28 **South Ockendon.** The nucleated settlement of South Ockendon was likely to have been located around the Church of St Nicholas and farmsteads scattered throughout the parish.
- 1.4.29 A medieval moated manor was located at South Ockendon Hall, which is now scheduled (1002155). The manor, c 1km west of the site, was known as 'Bruyns' and was certainly established by the 12th century but may have late

Saxon origins (Fig. 2). This manor house may have been rebuilt several times during the post-medieval period. The moated site does not have any remaining structures internally except part of a medieval gatehouse. It is likely that medieval and post-medieval remains may be located below ground here.

- 1.4.30 This manor was split in the early 16th century and the manor of Groves was created to the north (see below). It is possible that there were water management ditches associated with the moat, though these are unlikely to extend into the site. A possible watermill, which was later replaced by a windmill, was located on the south side of the moat. This is thought to be post-medieval in date, but it is possible the watermill may have been medieval in origin and contemporary with the medieval moat. This would have required an extensive water management system of drainage ditches, leats and sluice gates which may have extend into the area of the site. It seems plausible that the moat and possible watermill were fed by a spring line on the terrace since the Mar Dyke river is located downslope to the east.
- 1.4.31 It is possible that there was a medieval settlement located around the area of the moated manor, which may extend eastwards, perhaps as far as the site. Cropmarks have been also identified 400m north-west of the moated manor house. These include rectangular enclosures, linear features and pits. In addition, an east-west trackway was identified by the aerial survey to the north-west of the hall along with a rectangular enclosure. It is possible this track could be medieval or earlier in date. Further linear features have been recorded as cropmarks c 1.5km west of the site. It is possible the enclosures and linear features could define stock enclosures and field systems associated with the manor. Alternatively, these features may of post- medieval date and associated with the later manor house.
- 1.4.32 **Orsett.** The site is located at the western extent of the manor and later parish of Orsett (Fig. 1). The site of Bishop Bonners Palace is scheduled (1111592) and located 900m south-east of the scheme on the north edge of Orsett. This ringwork and bailey earthwork belonged to the Bishops of London during the medieval period. The later medieval settlement of Orsett was situated south of Bishop Bonners Palace around the Church of St Giles and All Saints (1147049). The Church of St Giles and All Saints located c 2km south-east of the site has elements of architecture dating to the 12th century with extensive 14th and 15th century alterations. The later medieval settlement of Orsett was located c 2km south-east of the site.
- 1.4.33 The cropmarks of a possible medieval moated site were identified on the slopes of the valley c 500m south of Land Parcel 45A. Several other possible medieval moated sites have been identified as cropmarks just east of the site and within the parish of Orsett. This includes the cropmarks of two sub-rectangular enclosures joined by a wide ditch located c 1km east of Land Parcel 45B. This could indicate the site of a double medieval moated site. An additional ditch is located just north of the easterly ditch. Another possible moat was recorded nearby but the HER recorded this as destroyed so it may be on the site of a modern reservoir.
- 1.4.34 A number of possible medieval or post-medieval field boundaries were identified by the aerial mapping survey fairly close to the site and within the parish of Orsett. These include a number of NNW-SSE aligned linear features

on a promontory c 1km east of Land Parcels 45C and 45B. There are also a number of NNW-SSE and ENE-WSW aligned linear features on a terrace c 750m south of Land Parcel 45A. These are also likely to represent evidence of medieval or post-medieval field boundaries. Two medieval ditches were recorded c 1km east of Land Parcel 45C during archaeological monitoring for the Horndon to Barking Gas Pipeline. One ditch was parallel to and approximately 3m from a low hedgerow and a small, metalled trackway. Excavation of one of these ditches produced two sherds of 12th-13th century pottery.

- 1.4.35 **Post-medieval period.** During the post-medieval period the road network in the area surrounding the site probably continued without significant change from that of the later medieval period. In relation to the principal estates of this period, the wider site, covered by WSI P, was located within the North Ockendon Hall estate, the Grove Barns estate, the South Ockendon Hall estate and the Orsett Hall estate. Prior to the later 20th century this area retained a largely rural character with dispersed farmsteads along tracks.
- 1.4.36 The tithe map for North Ockendon (c 1841) indicates that the northernmost part of the site was in use as arable land owned by Richard Benyon of North Ockendon Hall.
- 1.4.37 The former later medieval or early post-medieval manor of Groves Barns is probably located adjacent and west of the site within an area of woodland. This manor may have been established c 1531 when the manor of Bruyns (South Ockendon Hall) was split, or there may have been an earlier building on this site. This manor house was recorded as having 22 hearths in 1670, which was the largest number of hearths for South Ockendon parish and was therefore a substantial manor house. The manor house was extant until at least c 1772 but was demolished soon after. The only remains of this manor house above ground is a late 16th-early 17th century gateway and wall, now grade II listed (1147431) and located c 100m north-east of the site. The tithe map for South Ockendon (c 1840) indicates that Land Parcel 43 was in use as arable land within estate of John Henry Stewart of the manor of Groves.
- 1.4.38 An estate map of South Ockendon dated 1691 indicates the extent of the manor of South Ockendon. The northern boundary of this manor was formed by field boundaries and one of these bisected the northern part of the site. This map also shows the post-medieval manor of Groves Barns. The tithe map for South Ockendon (c 1840) shows that Land Parcels 45 and 46 were in use as arable and pasture fields which belonging to the estate of John Cliff of South Ockendon Hall. The parish boundary on the east was the Mar Dyke river. Several post-medieval field boundaries were recorded by the HER just east of the Mar Dyke, in Land Parcel 45B. These would have been located within the South Ockendon manor estate but have subsequently been levelled.
- 1.4.39 The relatively straight course of the Mar Dyke river on the 1691 estate map appears to match the modern route of the river, suggesting that it might have been canalised, or at least straightened, prior to 1691. Records of flooding of the river in the 18th century as far up as Stifford, however, may indicate that the canalisation was later than this. Chapman and Andre's map of Essex of 1777 certainly shows the Mar Dyke following the canalised course, so it

probably took place in the third quarter of the 18th century. Mar Dyke Fen is marked on this map east of the canalised course, bounded on the south side by a series of farms: unnamed, Jotts, unnamed (containing only one building), Hoblets, unnamed and Larkins. The same outline is shown on the 1805 Ordnance Survey map, but this usefully shows the promontory of high ground bounding the fen on the north just east of Land Parcel 45C.

- 1.4.40 A post-medieval mill was located c 700m south of Land Parcel 43, on the south side of the medieval moated manor of South Ockendon Hall (1002155). This mill was a post-medieval wind powered smock mill which had been built on the site of a possible former watermill. The windmill was demolished in 1978. No trace of the watermill or windmill was found during a site visit in 2011. It is possible that the watermill or windmill could have been medieval in date. As mentioned above, a series of medieval or post-medieval water management ditches may associated with this mill site.
- 1.4.41 The Orsett enclosure map of 1837 shows the extent of Mar Dyke Fen, which had not changed since 1805. The 1840 tithe map for Orsett shows that the southern part of the site had number of owners including the Baker family and William Wingfield of Orsett Hall. There are several field boundaries, which have been recorded by the aerial survey that lie c 1km south of the site. These field boundaries appear on the 1840 Orsett tithe map and are therefore likely to be post-medieval in date, but some may be medieval in date.
- 1.4.42 The area just to the south of the site is still labelled as Orsett Fen on the tithe map and this area is blank on the map and also on the later 19th century OS maps, showing that this area was still too wet to make use of for arable or pastoral purposes.
- 1.4.43 The tithe maps and later 19th century OS maps indicate that there were two post-medieval farms located close to or on the periphery of the site. Thrifts and Abrahams Farm, which originated in the later medieval period, lay just to the east of Land Parcel 45C and Old Barn Farm on the western edge of Land Parcel 45C. Both farms were demolished by the 1970s.
- 1.4.44 **Modern.** A number of 20th century military sites are located within the wider area but none of these are located within the site. These comprise a First World War landing site, a Second World War observation post, now destroyed, two heavy anti-aircraft gun sites and a Ground Controlled Interception Station.
- 1.4.45 In the late 20th century parts of the area surrounding the site were subjected to intensive quarrying. This removed historic field boundaries and probably buried archaeological remains, which may have been present in these areas.
- 1.4.46 **Undated features and cropmarks.** There are a number of undated features which have been recorded within the site. This includes the two cropmark rectilinear enclosures and linear features in Land Parcels 46 and 45D, which have been discussed above and may have either prehistoric or Roman origins. The possible ditch and bank at the edge of the promontory to the east of Land Parcel 45C may be defensive in nature or may just be an unusually shaped field boundary above the floodplain. As discussed above, this may be of prehistoric origin or of medieval to post-medieval origin. A possible medieval moated site has also been recorded as a cropmark c 150m north-west of the site.

2 Project Aims

2.1 General aims

2.1.1 The general project aims of the project were as follows:

- i. To establish the presence or absence of archaeological remains along the line of the scheme, and the extent of any areas where remains appear likely to be absent;
- ii. In areas where archaeological remains are known or suspected, to clarify the reliability of the cropmark or geophysical survey evidence;
- iii. In areas where no archaeological remains are indicated by aerial or geophysical survey, to clarify whether this apparent absence of remains is genuine;
- iv. To determine the degree of complexity of any surviving horizontal or vertical stratigraphy, and in particular, to investigate areas where topography indicates the likelihood of deep deposit sequences for evidence of buried archaeological horizons and palaeo-environmental sequences;
- v. Where remains are present, to determine the period(s) represented, the extent, state of preservation and character of the archaeological remains;
- vi. To establish the range and state of preservation of archaeological artefacts, and through their recovery and examination, to establish the potential for information about the economy, status and contacts of past inhabitants of the scheme footprint;
- vii. To determine whether palaeo-environmental remains are preserved, and, where these are found, to determine their types (eg charred plant remains, waterlogged remains, molluscan remains), state of preservation and potential for environmental information. This will be achieved through the recovery of samples from sedimentary sequences and archaeological features suitable for assessment of a range of palaeoenvironmental remains (e.g. charred and waterlogged plant remains, charcoal, insects, pollen, diatoms, ostracods/foraminifera and molluscs) and scientific dating (e.g. radiocarbon and OSL dating);
- viii. To investigate and record the extent, character and chronology of the sedimentary sequences, in particular those immediately adjacent to and in floodplains, contained within palaeochannels or in dry valleys, and to use the data to refine existing geoarchaeological (predictive) deposit models.
- ix. To place any identified archaeological remains into their local and, where appropriate, regional or national context, and to assess the implications of any such discoveries for our current understanding of settlement and landscape change in the area, including an assessment of the associations of any remains with reference to the historic landscape;
- x. To provide sufficient information to enable the LTC archaeological advisor, in consultation with the Key Archaeological Stakeholders, to determine the significance of the archaeological assets identified within the land parcel;

- xi. To provide a report on the discoveries to inform the Environmental Statement (ES) supporting the Development Consent Order (DCO) and support the preparation of a further archaeological mitigation strategy for the Enabling Works and Construction phases of the scheme;
- xii. Following the DCO, to deposit the report in the public domain, and to generate an accessible and useable archive which will allow future research of the evidence to be undertaken.

2.2 Specific objectives

2.2.1 The specific project objectives, which were set out in WSI P and that are relevant to this site (Land Parcels 43, 45A-E and 46) were as follows:

- xiii. To conduct the programme of archaeological investigation within the general research parameters and objectives defined by the revised East of England Research Framework (Medlycott 2011);
- xiv. To establish the extent, depth and complexity of slope deposits, colluviation and alluviation, and to determine whether buried archaeological activity is preserved beneath or within them;
- xv. To identify areas along the edge of the former palaeochannels that may have been used for activity in the past, together with any islands or areas with only shallow seasonal inundation within the palaeochannels that may have had human activity, and if found, to characterise the type, date and complexity of activity upon and associated with them;
- xvi. To aim to relate any activity found on the valley slopes to activity on the higher ground, and in particular to the cropmark evidence;
- xvii. To clarify whether the cropmarks provide an accurate representation of the range, quantity and types of archaeological features present on the areas without alluvial covering within the site;
- xviii. To look for evidence of domestic activity of earlier prehistoric date that may be associated with the possible monuments suspected from cropmarks to the west and south of the site;
- xix. To establish the character and date of the two rectilinear enclosures and a nearby field system within the northern part of the site;
- xx. To clarify the location and character of the supposed Roman cemetery found in the 19th century; and,
- xxi. To establish the date of the possible medieval or post-medieval field boundaries that have been identified within the eastern and southern part of the site.

3 Methodology

3.1 Constraints

- 3.1.1 Several constraints limited the area of the site available for trial trenching. A High Pressure gas pipeline, aligned north-south, runs through Land Parcels 45A-C. A High Voltage Overhead Power Line is aligned NW-SE and passes through Land Parcels 45A-D. An unexploded ordnance (UXO) survey also highlighted parts of Land Parcels 43 and 46 in the north-west of the site, which present a moderate risk for the presence of UXO, the remainder of the site presenting a low risk. Unexploded bombs are mapped in the north corner of Land Parcel 46 and just outside its western boundary. Elsewhere others are mapped on the western edge of Land Parcel 45B and just to the south of Land Parcel 43. Great Crested Newts are present in almost all of the ponds within the Mar Dyke valley. Where necessary the appropriate licence was acquired from Natural England and appropriate measures for their protection put in place.
- 3.1.2 These limitations were taken into account when designing the detailed trench layout. Minor alterations to the layout were implemented during the fieldwork phase to avoid exclusion zones once these had been established on site and where initial trench layouts overlapped.
- 3.1.3 In accordance with the safe system of work established by Balfour Beatty, excavation generally ceased at a maximum depth of 1m below ground level. Inevitably, several of the larger features could not be excavated to full depth within the constraints of this programme of works. In Land Parcels 45B and 45C, however, and occasionally in Land Parcels 45D and 46, permission was obtained to extend and deepen trenches to 2m where deemed appropriate by OCA to fulfil the aims of the investigation.

3.2 Methodology for the evaluation

- 3.2.1 As indicated by WSI P (OA 2021, section 4.1.14), only those parts of the land parcels likely to suffer significant direct impact from the scheme were evaluated. Those parts of the land parcels that it was considered would suffer either minimal or no impact were therefore not investigated, which in practice meant the western parts of Land Parcels 45B, 45C and the north-western and eastern parts of Land Parcel 45E.
- 3.2.2 The total area within Land Parcels 43, 45A-E and 46 likely to suffer direct impact from the scheme and available for investigation excluding areas of services, hedgerows and other constraints was c 46ha. The final excavated archaeological trial trench layout comprised a total of 240 trenches, with the majority measuring 30m long x 2m wide and 41 measuring 30m long x 6m wide. This represented an overall evaluation sample of approximately 4%. The location of the trenches is shown on Figure 2.
- 3.2.3 The trench design was developed to target cropmark features identified by the aerial investigation and mapping report (Place Services, 2019), anomalies identified in the geophysical survey (Magnitude Surveys 2020) and otherwise to provide even coverage of the blank areas. Several trenches were not laid

out on a standard grid but adjusted slightly to account for the exclusion zone associated the High-Pressure gas pipeline in Land Parcels 45A-C. Trenches were spaced to avoid any large gaps, and to cover all underlying geologies. A proportion of the trenches have been aligned at right angles to the orientation of the valley slope. (Fig. 2).

- 3.2.4 In Land Parcel 45E Trenches 282-296 and 298-302 were removed from the project scope following consultation with the Client and the Place Services, Essex County Council. However, Trenches 297 and 303 in this Land Parcel had been opened and recorded by the time of this decision. Elsewhere, in Land Parcels 45B and 45C Trenches 365, 398, 405, 424, 428, 439, 454 and 456 were repositioned to move them out of the High Pressure Gas pipeline exclusion zone. In Land Parcel 45D Trenches 340, 348, 357, 373, 374 and 389 were repositioned to move them out of the High Voltage Overhead Power Line exclusion zone. Trench 382 was repositioned to avoid a water main and Trench 393 to avoid the compound footprint.
- 3.2.5 All trenches were located using a Global Positioning System (GPS) prior to machine excavation. All trenches were excavated using a tracked excavator fitted with a toothless bucket under constant archaeological supervision.
- 3.2.6 Revealed features were hand cleaned where appropriate and sampled by hand excavation. They were recorded as outlined with the approved WSI. All finds were bagged by context throughout the evaluation and were recovered for further investigation.

4 Results

4.1 Introduction and presentation of results

- 4.1.1 The results of the evaluation are presented below and include a stratigraphic description of the trenches that contained archaeological remains. The full details of all trenches with dimensions and depths of all deposits, and a summary of the finds, can be found in Appendix A. Finds data are tabulated and reported upon in Appendix B, and environmental materials in Appendix C. The accompanying geoarchaeological report is also provided in Appendix D, along with its associated figures and plates.
- 4.1.2 Context numbers reflect the trench numbers unless otherwise stated. The first numerals of a context number reflect the trench number whilst allowing for a maximum range of 100 individual records for any one trench. For example, ditch 30602 is a cut within Trench 306, while posthole 31105 is a cut within Trench 311.
- 4.1.3 An overview of the results for the site is shown on Figure 2, and more detailed views of each of the Land Parcels and the trenches within them on Figures 3-13. Further detailed plans and sections of the trenches that contained archaeological features are shown on Figures 14-51.

4.2 General soils and ground conditions

- 4.2.1 The ploughsoil typically measured between 0.2m and 0.45m thick, although in several trenches it measured 0.12-0.15m thick and in several other examples up to 0.6m thick. The variation in depth is likely the result of mixed agricultural activities across the site. Across much of the site the ploughsoil overlay a subsoil layer, typically measuring between 0.07m and 0.3m thick. Slightly thicker deposits of subsoil measuring up to 0.5m thick were recorded in Trenches 337, 396 and 401.
- 4.2.2 The presence of alluvial deposits is described in detail in the geoarchaeological report that accompanies this report (Appendix D). In summary, these deposits, which comprise an element of the Holocene sequence throughout LPs 43, 45a-e and 46, vary over three main zones. On the higher ground in the dry valley moving to the north-west away from the valley bottom and on the shallow valley promontories the sequence is shallow and comprises modern topsoils, subsoils and thin alluvial layers with archaeological activity occurring beneath them. The sequence becomes thicker on the floodplain margins, consisting of leached horizons and alluvial deposits that overlie weathered London Clay and Pleistocene Head deposits. Further into the floodplain the sequence becomes deeper and more complex, comprising potential channel deposits, leached horizons overlain by intercalated alluvium and stabilisation horizons. Alluvial deposits were recorded in Trenches 362, 394, 397, 400, 403-408, 412, 414-415, 417-418, 425-427, 430, 433-436, 438, 440-441, 443, 445, 449-452, 456, 461 and 531.
- 4.2.3 The underlying natural geology comprised London Clay Formation across the whole site. The superficial geology across much of the site, as noted above, is alluvium or, in the western end of Land Parcel 46 and in Land Parcel 43,

Head Clay. Only a very few examples of possible colluvial deposits were recorded across the site - in Trenches 361, 381 and 495.

- 4.2.4 The course of the Mar Dyke river prior to canalisation has been traced using LiDAR data and the results of the geophysical survey (OA 2021, figs 4b and 4c), and it is evident that the main palaeochannel runs north-south to the east of the modern course of the canalised river, then continues to meander southwards, passing just east of Land Parcel 45D to then cross the east side of Land Parcel 45C. There are also faint indications of a wide meander continuing across the southern end of Land Parcel 45C and returning across the northern part of Land Parcel 45B to the west of the existing canalised river. Possible palaeochannel deposits were identified overlying weathered London Clay deposits at the southern end of Land Parcel 45C, in Trenches 433 and 434, but none were evident in the northern part of Land Parcel 45B (Appendix D).
- 4.2.5 The fieldwork was undertaken predominantly in reasonably fine weather with no periods of rain sufficient to cause any of the trenches to flood. The majority of deeper features remained dry throughout the evaluation and there was no measurable impact associated with prevailing weather conditions. Where present, archaeological features were easily identifiable against the natural geology, and the initial investigation of features of natural origin provided a solid benchmark for distinguishing these from archaeological features without the later need for excavation.

4.3 General distribution of archaeological deposits

- 4.3.1 Archaeological features were revealed in 67 of the trenches: 306, 311, 328, 330, 336, 341, 343, 346, 349, 351-352, 354, 359, 362, 365, 369-370, 372, 374-376, 378-379, 382-383, 388-390, 392, 406, 409, 419, 427, 442-443, 448, 450-452, 454-455, 457, 459-462, 464, 466, 482, 487-489, 492-494, 502, 505, 514, 516, 519-521, 523, 525-526, 528 and 534.
- 4.3.2 The predominant concentration of archaeological features lay across much of Land Parcel 45D and the southern part of Land Parcel 46, and in a broadly north-south alignment through Land Parcels 45B and 45C. There were smaller clusters of features in the north of Land Parcel 46 and the east half of Land Parcel 43. Features predominantly comprised a combination of enclosure and field boundary ditches and gullies, pits, postholes, possible hearths and possible occupation deposits, along with several naturally derived tree-throw holes and a small number of natural features such as periglacial cracks. Where features were dateable, they ranged from the middle Bronze Age to Roman period and from the early medieval to post-medieval periods.
- 4.3.3 All other trenches were devoid of archaeological remains or contained only natural features. Whilst two of the natural features were investigated, specifically in Trenches 341 and 527, the majority, in Trenches 311, 328, 335, 337, 354, 359, 372, 388, 390, 417, 426, 450, 452, 453, 460, 468 and 483 were recorded in plan but not excavated.

4.4 Trenches 306, 311, 328, 330 and 336 (Figs 3 and 14-17)

- 4.4.1 The remains of six moderately sized NNW-SSE aligned ditches and a possible ditch or natural periglacial feature were recorded in Trenches 306, 311, 328 and 336 in Land Parcel 45E.
- 4.4.2 **Trench 306** was crossed by ditches 30606 and 30609 and ditch 30602 terminated within the trench (Fig. 14). All of these ditches had sloping sides with rounded bases and measured between 0.5-0.85m wide and 0.17-0.3m deep. Ditches 30602 and 30606 each had a single fill; ditch 30609 had a primary and a secondary fill. A small assemblage of late Bronze Age/early Iron Age pottery, three flint flakes and two fragments of fired clay were recovered from the 30611, the secondary fill of ditch 30609 and a single flint flake and a fragment of fired clay from 30603, the fill of ditch 30602. No continuation of ditch 30606 was seen in Trench 318 to the south.
- 4.4.3 One pit was also recorded at the west end of Trench 306. Pit 30604 lay almost opposite to ditch terminus 30602, had moderately sloped sides with a flattish base and measured 0.74m long by 0.61m wide and only 0.08m deep. It was broadly oval in plan, although its southern edge was not fully exposed in the trench. No finds were recovered from its single fill (Fig. 17).
- 4.4.4 **Trench 311** was crossed by ditches 31102 and 31112, which were of similar dimensions and profile to the ditches in Trench 306, and had only one fill. Two flint flakes and a scrap of pottery assigned an 11th-13th-century date came from 31113, the fill of ditch 31112 (Fig. 17, Plates 1 and 2). Ditches 30609 and 31112 were almost in line with one another, and may represent parts of the same boundary, in which case the prehistoric pottery in 30609 was residual, or the medieval scrap in 31112 was intrusive. Ditch 31112 was also almost in line with ditch 30602, and it is also possible that they were also associated.
- 4.4.5 Four postholes, three in a roughly east-west line and the fourth to the north-east, were found in Trench 311 (Fig. 14: 31105, 31106, 31109 and 31110). All of the line of three postholes were excavated; posthole 31109 remained unexcavated. All four were broadly circular in plan and between 0.30m and 0.34m in diameter. Posthole 31110 was shallowest at 0.1m and 31105, which cut 31113, the fill of ditch 31112, the deepest at 0.23m. Each of the excavated examples had very steeply sloped to vertical sides and a flattish base (Fig. 17, Plates 7-10). Two sherds of late Bronze Age/early Iron Age pottery and three burnt flint flakes were recovered from 31108, the single fill of posthole 31105, and three sherds of similar date and two burnt flint flakes were recovered from 31107, the fill of posthole 31106. One sherd of late Bronze Age/early Iron Age pottery and three sherds of broadly Roman date were, however, recovered from 31114, the fill of posthole 31110. It is possible that the Roman sherds from shallow posthole 31110 were intrusive, and that these features belonged to a structure of late Bronze Age/early Iron Age origin. Alternatively, the prehistoric finds may have been residual, and the structure of Roman or later date.
- 4.4.6 **Trench 328** was located c 135m south of Trench 311 (Figs 3 and 15). Ditch or periglacial feature 32808/32804 was aligned NNW-SSE and had very steep or vertical sides, but was not bottomed (Fig. 17). Its fills were very irregularly deposited, suggesting a natural origin, but fill 32807 feature yielded a sherd of

Roman pottery and upper fill 32809 a sherd of 16th-17th century pottery, a fragment of fired clay and a flint flake (Fig. 17, Plate 3).

- 4.4.7 Ditch 32802 in Trench 328 lay on a more NW-SE alignment (Figs 3 and 15), and was 0.6m wide by 0.3m deep with a V-profile of sloping sides and a narrow rounded base (Fig. 17, Plate 4). No finds were recovered from its single fill.
- 4.4.8 **Trench 330** lay c 22m south of Trench 228 and contained two ditches and a gully (Figs 3 and 15, 33002, 33004 and 33006). Ditches 33002 and 33004 were aligned WSW-ENE, c 12m apart, and had steeply sloping sides with flat bases. Ditch 33002 measured 1.5m wide by 0.35m deep and ditch 33004 (Fig. 17, Plate 5) measured 0.94m wide by 0.23m deep. Both had only a single fill, and no finds were recovered from either. Gully 33006, in the north of Trench 330, was aligned NW-SE and measured 0.38m wide by 0.1m deep and contained a single fill from which no finds were recovered (Fig. 17, Plate 6).
- 4.4.9 **Trench 336** lay c 250m south-east of Trench 311m, and contained ditch 33603 (Fig.16). It was on the same NNW-SSE alignment as the ditches in Trenches 306 and 311, and was also of broadly similar size and profile, but contained two deliberately deposited fills, from which no finds were recovered (Fig. 17).

4.5 Trenches 341, 343, 346, 349, 351, 352, 354 and 359 (Figs 4 and 18-20)

- 4.5.1 These trenches covered the north-eastern part of Land Parcel 45D, and revealed a range of ditches and possible gullies on roughly perpendicular alignments, some north-south by east-west, others NNW-SSE by WSW-ENE, and a couple aligned NW-SE. There were also two pits and a possible quarry pit or infilled pond.
- 4.5.2 **Trench 341** revealed a ditch close to its east end on a NNW-SSE alignment (Fig. 18). Ditch 34107 had moderately sloped sides with a rounded, flattish base and measured 2.16m wide by 0.28m deep (Fig. 20, Plate 11). Two small sherds of 11th-13th-century pottery were recovered from its single fill along with a few fragments of animal bone. The ditch was cut on its east side by a small pit 34109, which also cut another small pit (34111) slightly further east. Pit 34109 was oval in plan, measured c 1.0m long on its north-south axis by 0.94m east-west and was 0.16m deep with moderately steep sides and a flat base (Fig. 20). No finds were recovered from its single fill. Pit 34111, which was partly cut away by pit 34009, appeared to have been oval in plan. It had an almost conical profile, with moderately steep sides and a pointed base and measured 0.64m along its north-south axis by 0.6m east-west and was 0.26m deep (Fig. 20). No finds were recovered from its single fill. No continuation of this ditch was seen in Trench 350 to the south-east.
- 4.5.3 Feature 34103 lay to the west of ditch 34107, and was investigated as another ditch on a roughly NW-SE alignment. It measured 1.35m wide by 0.32m deep, with an irregular base, and was filled with redeposited natural. Two very small sherds of 11th-13th-century pottery were recovered from its single fill. Its irregular character may indicate that it was the site of a former hedge or tree next to the ditch.

- 4.5.4 The western half of this trench was occupied by 34105, a large quarry or pond, which was at least 11m long and 2m wide, continuing beyond the trench edge on the north, west and south. This feature corresponded to an extensive geophysical anomaly, which could suggest a very extensive, perhaps naturally infilled deposit. A 1m boxed section through the feature showed that it was 0.9m deep with a single fill, which contained a little charcoal and amorphous CBM, which was not retained (Fig. 20, Plate 20).
- 4.5.5 **Trench 343** lay c 60m east of Trench 341 and contained three ditches, two on a broadly N-S alignment, the third aligned ENE-WSW. Ditch 34306 was the westernmost ditch, measured 0.9m wide by 0.46m deep and had moderate to steep sloping sides and a rounded base. No finds were recovered from its single fill (Fig. 20, Plate 12). Ditch 34304 lay 5m east of 34306, was aligned N-S and measured 0.6m wide by 0.18m deep with moderately steep sides and a flat base (Fig. 20). It had a single fill that contained an iron nail and charcoal flecks; a small quantity of charcoal and a charred vetch/wild pea seed were recovered from environmental sample S.95. Either of these ditches may have continued as ditch 35902 recut as 35904 in Trench 359 to the south.
- 4.5.6 Ditch 34302 lay east of ditch 34304, and the width was only just exposed within the trench, but was aligned ENE-WSW. It measured 0.95m wide by 0.32m deep, and had very steep, slightly irregular sides with a flattish, irregular base (Fig. 20, Plate 18). There was evidence of animal burrowing within the single deliberately deposited fill, which probably explains the irregularities in its form. No finds were recovered from the fill.
- 4.5.7 **Trench 349** lay south of Trench 341, and contained two east-west ditches and a gully on a NNW-SSE alignment (Fig. 18). Ditches 34902 and 34904 ran parallel some 9.5m apart. The northern ditch (34902) had moderately steep sides, rounding off to a flattish, slightly irregular base and measured 1.0m wide by 0.7m deep. Ditch 34904 to the south had more irregular steep sides with a flat base and measured 0.9m wide by 0.57m deep (Fig. 20). Both contained single charcoal flecked fills from which no finds were recovered. Ditch 34904 cut the northern end of gully 34906, which ran southwards along the trench roughly at right angles to it. Gully 34906 was slightly irregular in plan along its 10m exposed length but measured approximately 0.32m wide by 0.16m deep. It had steep sides with a concave base and no finds were recovered from its single slightly charcoal flecked fill (Fig. 20).
- 4.5.8 No continuation of the gully was seen in Trench 357 to the south, nor of either east-west ditch in Trench 348 to the west (Fig. 4). There was equally no continuation of 34902 in Trench 351 to the east, but ditch 35103 was in line with ditch 34904, so could represent a further element of the same linear boundary, although if so there was clearly a wide gap between them, as no trace of the ditch was seen in Trench 350 in between.
- 4.5.9 **Trench 351** was located 70m east of Trench 349, and contained only ditch 35103. It had moderately steep sides to a rounded, flattish base and measured 1.1m wide by 0.47m deep (Fig. 20, Plate 19). One small late Bronze Age-early Iron Age sherd was recovered from its primary fill and one fairly large Roman sherd, along with two flint flakes, one of which was burnt, from its final fill.
- 4.5.10 **Trench 359** lay south of Trench 351 and c 75m south of Trench 343 (Fig. 18). It contained a single ditch on a N-S alignment, whose line was close to that of

ditch 34306, and may have been a continuation. Ditch 35902, was recut and partially removed on its western side by ditch 35904. Ditch 35902 had shallow sloped sides with a flat base and measured at least 1.1m wide by 0.14m deep. The recut had very steep sloped sides but was not bottomed, measuring 0.74m wide and at least 0.52m deep (Fig. 20, Plate 17). Neither the single fill of ditch 35902 nor the two fills in recut 35904 produced datable finds. The final recut fill appeared to have been deliberate.

- 4.5.11 **Trench 352** lay east of Trench 351, and contained a gully on a broadly N-S alignment, although slightly curving (Fig. 19). Gully 35202 measured 0.45m wide by 0.08m deep with sloping sides and a rounded base (Fig. 20, Plate 14). No finds were recovered from its single fill.
- 4.5.12 **Trench 346** was 58m north-east of Trench 52 along the eastern boundary of Land Parcel 45D, and contained a single ditch on a NNW-SSE alignment parallel to the modern field boundary. Ditch 34603 had moderate to steeply sloped sides with a rounded base and measured 0.66m wide by 0.31m deep (Fig. 20, Plate 13). This ditch aligned very accurately with a former historical field boundary, depicted on the 1st Edition Ordnance Survey (OS) mapping. On that basis it is likely to be of post-medieval origin, although no datable remains were recovered from its single fill. No trace of this ditch was, however, seen in Trench 354 to the south.
- 4.5.13 **Trench 354** contained a wide ditch near to the western end of the trench. Ditch 35404 was a substantial feature and measured 3.7m wide by at least 0.66m deep, but was not bottomed, with steep, somewhat irregularly sloping sides (Fig. 20, Plate 16). It contained three naturally accumulated fills, the middle of which (35406) contained a small fragment of post-medieval or modern tile. It is possible that this was another element of the historic field boundary depicted on 1st Edition OS mapping, which was also exposed as ditch 34603 in Trench 346 to the north. Subcircular feature 35403 just west of the ditch was also investigated, but proved to be of natural origin.

4.6 Trenches 362, 369 and 370 (Figs 4-5, 21 and 23)

- 4.6.1 These trenches were located on the east side of Land Parcel 45D south of Trench 354. Trench 362 was the only trench in this land parcel to contain alluvium, which occurred much more frequently in Land Parcel 45C to the east.
- 4.6.2 **Trench 362** contained a ditch aligned WSW-ENE and a gully north of that orientated NW-SE, both sealed beneath a thin alluvial deposit (36201). Ditch 36206 measured 1.64m wide by 0.26m deep and had gently sloping, slightly irregular sides and a flattish, irregular base (Fig. 23). There were no finds other than a few animal bones in its single fill (36207). Gully 36204 was located at the north end of Trench 362. It had very steep sides with a rounded to flattish base and measured 0.22m wide by 0.17m deep (Fig. 23, Plate 15). No finds were recovered from its single charcoal flecked fill.
- 4.6.3 **Trench 369** was located south-west of Trench 362, and contained a ditch and a gully. Ditch 36903 was only identified in the west-facing trench baulk after machining (Fig. 23), so its orientation is unclear. Ditch 36903 measured 1.45m wide by 0.38m deep with a moderately steep, irregularly sloped north side and more regular south side and a flattish base. No finds were recovered from its

slightly charcoal-flecked single fill. Gully 36905 was aligned NNW-SSE, and measured 0.44m wide by 0.17m deep. It had sloping sides with a rounded base and a single fill, from which no finds were recovered.

4.6.4 **Trench 370** lay east of Trench 369 and south of Trench 362 and contained two ditches (Fig. 21). Ditch 37006 had sloping sides with a flat base and measured 1.56m wide by 0.72m deep (Fig. 23). The only finds recovered from its single fill were a few fragments of animal bone.

4.6.5 Ditch 37004 was only evident in the southern baulk of Trench 370. It measured 1.12m wide by 0.46m deep with steeply sloping sides and a rounded to flattish base (Fig. 23). No finds were recovered from its single fill. This ditch lay a similar distance from the modern field boundary as ditch 34603 some way to the north, and it is possible that it represents another element of the former historical field boundary depicted on 1st Edition OS mapping.

4.7 Trenches 372 and 383 (Figs 5, 22 and 23)

4.7.1 These two trenches lay on the west side of Land Parcel 45D, west of the cropmark rectilinear enclosure (Fig. 5). Trench 372 was orientated east-west and contained two north-south ditches and a natural feature (Fig. 22). Ditch 37202 lay at the eastern end of Trench 372, measured 1.12m wide by 0.26m deep with steeply sloping sides and a rounded base (Fig. 23). No finds were recovered from its single fill. Ditch 37204 lay c 13m west of ditch 37202. It had steeply sloping sides with a flattish base and measured 0.72m wide by 0.16m deep. There was a single fill (37205), from which a single fragment of post-medieval to modern tile was recovered. No continuation of 37204 was seen in Trench 356 some way to the north. Linear feature 37206, also aligned north-south to the west of 37204, was tested by hand but proved to be natural.

4.7.2 **Trench 383** lay south-west of Trench 372 and contained a single tree-throw hole. Tree-throw hole 38302 was partially exposed in the northern baulk of the trench and was quite irregular in plan. It measured c 1.96m by 1.02m and was 0.4m deep with steeply sloping sides and an irregular flattish base. No finds were recovered from its single fill, which was only notable for frequent charcoal flecking, possibly an indication of *in situ* burning.

4.8 Trenches 374 and 375 (Figs 4-5, 24 and 26)

4.8.1 These trenches were targeted upon a rectilinear cropmark enclosure measuring c 36m NNW-SSE by c 55m ENE-WSW that was plotted in the central southern part of Land Parcel 45D, east of Trench 372. The trenches exposed two substantial ditches, one with two possible recuts, that corresponded closely with the cropmark ditches of the north and east sides of the enclosure. Two smaller ditches were also found within the area of the cropmark enclosure (Fig. 24).

4.8.2 **Trench 374** was orientated NNW-SSE across the northern side and interior of the cropmark enclosure, and ditch 37402 lay at the north end of the trench. It was aligned ENE-WSW, measured 4.8m wide by 0.81m deep with sloping, slightly irregular sides and a flattish base (Fig. 26, Plate 21). The ditch contained only a single, slightly charcoal flecked, fill (37403) from which a substantial assemblage of medieval pottery ranging in date from the 11th to

the 15th centuries, a single post-medieval sherd and an iron nail were recovered.

- 4.8.3 **Trench 375** was aligned east-west and was targeted upon the east side and interior of the cropmark enclosure, which corresponded to ditch 37511 and its two probable recuts, 37506 and 37509. Only part of ditch 37511 survived, as much of its western half had been removed by deeper recut 37506. Ditch 37511 had a moderate to steeply sloping sides with a rounded base and measured at least 0.8m wide by 0.32m deep. No finds were recovered from its single fill. The centre of recut ditch 37506 had also been partially removed by further recut 37509, but both sides survived, together with much of the base (Fig. 26, Plate 22). Ditch 37506 measured 4.5m wide by at least 0.62m deep with stepped sloping sides and a flattish, slightly irregular base, although the bottom was not reached on the east. The single fill (37508) yielded two sherds of medieval pottery, a small assemblage of animal bone and a single burnt flint flake. The final recut, ditch 37509, measured 1.42m wide by at least 0.62m deep with sloping sides, but was not bottomed (Fig. 26, Plate 22). This ditch also contained a single fill (37507), which yielded two sherds of late Iron Age-early Roman pottery, 17 medieval sherds, a late medieval iron horseshoe, two flint flakes, nine burnt flint fragments and a fragment of post-medieval tile.
- 4.8.4 Ditches 37502 and 37513 lay c 13m and 17m to the west of ditch 37506 within the interior of the enclosure, and on similar alignments. Ditch 37502 had steeply sloping sides and a flat base with the appearance of a shovel slot (Fig. 26, Plate 23). It measured 0.7m wide by 0.39m deep and, contained a single fill from which no finds were recovered. Ditch 37513, which cut tree-throw hole 37504, lay 3.5m further west and had almost vertical sides with a rounded, to flat base and measured 1.06m wide by 0.69m deep. A sherd of late Iron Age-early Roman pottery was recovered from its single fill (37514). It is uncertain whether either of these ditches was related to the enclosure; no trace of either ditch was seen beyond the enclosure in Trench 359 some way to the north, but ditch 37903 to the south was in line with ditch 37513, and although wider, may represent a continuation, in which case 37513 was probably not contemporary with the enclosure.

4.9 Trenches 376 and 378 (Figs 4-5, 25 and 26)

- 4.9.1 These trenches lay east of the cropmark enclosure and south of Trenches 369 and 370, and contained three ditches, one aligned WNW-ESE and two aligned east-west, together with a pit.
- 4.9.2 Trench 376 was aligned north-south and revealed ditch 37602 aligned WNW-ESE at the north end. Ditch 37602 measured 1.2m wide by 0.2m deep with steeply sloping sides and a rounded, slightly irregular base (Fig. 26). No finds were recovered from its single fill. Ditch 37602 had been recut by ditch 37604, which had less steeply sloping sides with a rounded base and measured 0.0.58m wide by only 0.14m deep. Again, no finds were recovered from its single fill. No continuation of this ditch was seen in Trench 377 to the east.
- 4.9.3 Ditch 37606 lay at the south end of the trench and was aligned east-west. It had somewhat irregular, sloping sides with a rounded base and measured 2.1m wide by 0.51m deep (Fig. 26, Plate 24). Ditch 27606 contained two fills, the later of which (37608) appeared to have been deliberately deposited. This

final fill contained four sherds of late Iron Age-early Roman pottery and a fragment of post-medieval to modern tile. No continuation of this ditch was seen in Trench 378 further east.

- 4.9.4 Trench 378 was also aligned north-south and lay 63m east of Trench 376. Ditch 37804 and recut 37806 were aligned east-west in the northern half of Trench 378. Ditch 37804 measured 1.91m wide by 0.71m deep with steeply sloping sides with a broadly rounded, slightly irregular base (Fig. 26). No finds were recovered from its single fill. Ditch recut 37806 had steeply sloped sides with a flattish base and was slightly less substantial than its predecessor, measuring 1.31m wide by 0.61m deep. It contained a single fill from which no finds were recovered.
- 4.9.5 Pit 37808 was partially exposed south of ditch 37804 in the west side of Trench 378. It appeared to have a slightly irregular oval plan measuring c 0.85m wide north-south by at least 0.68m east-west. The feature was 1.06m deep with a very steep north side and a pointed base, and contained four fills, two of which contained some evidence of charcoal flecking (Fig. 26, Plate 25). No finds were recovered from any of its fills. Over the last fill the subsoil had survived, slumped into the top of the feature.

4.10 Trenches 379 and 382 (Figs 4-5, 27 and 32)

- 4.10.1 These trenches lay south of the cropmark rectangular enclosure and close to the southern edge of Land Parcel 45D, and revealed one large ditch crossing both trenches, together with a smaller ditch adjacent in Trench 382 (Figs 5 and 27).
- 4.10.2 **Trench 379** was located c 15m south of the cropmark enclosure discussed above, was aligned north-south, and contained a single ditch on a NNW-SSE alignment. Ditch 37903 measured 2.8m wide in plan, and 0.43m deep. Where excavated the western side was interpreted as bioturbated, but this was probably an earlier fill that extended all the way to the trench baulk. It had a sloping north-east side and a rounded base (Fig. 32, Plate 26). No finds were recovered from the excavated fill. Ditch 37513 within Trench 375 to the north was in line with ditch 37902, and although narrower, may have been a continuation.
- 4.10.3 **Trench 382** lay south-east of Trench 279, and contained two ditches on a NNW-SSE alignment at its western end. Ditch 38202 followed a very similar line to ditch 37903 and probably represents a continuation of the same feature. Ditch 38202 had splayed gently sloping upper sides and near-vertical lower sides, but was not bottomed for safety reasons. It measured 2.4m wide and at least 0.62m deep (Fig. 32, Plate 27). Of the three exposed fills only the last (38205) yielded datable finds, comprising a single sherd of Roman pottery and an undated fragment of CBM. Ditches 38202 and 37903, while somewhat morphologically different, probably represent parts of the same fairly substantial enclosure or field boundary ditch.
- 4.10.4 A smaller ditch, 38206, lay c 5m east of ditch 38202. It had steeply sloping sides and slightly rounded base, and measured 0.64m wide by 0.42m deep (Fig. 32, Plate 28). A sherd of medieval pottery of 13th to 15th-century date was recovered from its single fill.

4.11 Trenches 388, 389, 390 and 392 (Figs 4-5, 28 and 32)

- 4.11.1 These trenches lay south-west of the rectangular cropmark enclosure and west of Trenches 379 and 382, and contained three ditches and three probable gullies aligned broadly ENE-WSW (Figs 5 and 28).
- 4.11.2 **Trench 388** was aligned north-south, and contained a single ditch on an ENE-WSW alignment, narrowing towards the west. Ditch 38802 had sloping sides and a rounded base and measured 0.7m wide by only 0.18m deep (Fig. 32). No finds were recovered from its single fill. A circular soilmark (38804) at the south end of this trench was also investigated, but proved to be natural.
- 4.11.3 **Trench 389**, was located c 13m north-east of Trench 388, and contained a single ditch at its north-west end. Ditch 38903 had steeply sloping sides with a flat base and measured 0.85m wide by 0.45m deep (Fig. 32). It contained two charcoal-flecked fills but no finds. Ditch 38903 was orientated more NE-SW than ditch 38802, but was on a very similar alignment, and probably represents a continuation of the same ditch, although their profiles are rather different.
- 4.11.4 **Trench 390** was located south of Trench 389 and contained one wide ditch and two narrower ditches or gullies, all on ENE-WSW alignments, a pit and a posthole. Ditch 39003 lay at the north end of the trench, and was 2.65m wide by c 0.7m deep with steeply sloping sides and a flattish, slightly irregular base (Fig. 32, Plate 29). It contained three fills, none of which yielded any finds, although a moderate quantity of charcoal fragments, cereal grains and seeds were recovered from environmental sample S.94 taken from final fill 39006. Gully 39007 lay c 9.0m to the south-east. It had gently sloping sides with a rounded base and measured 0.3m wide by 0.05m deep (Fig. 32). No finds were recovered from its single fill. Ditch or gully 39009 lay a further c 8.5m south-east of gully 39007. It too had gently sloped sides with a rounded base, but was wider, at 0.68m and was 0.14m deep (Fig. 32). Again, no finds were recovered from its single fill.
- 4.11.5 One pit and a posthole were also found at the south-east end of Trench 390. Pit 39011 was oval, measuring 0.63m by 0.32m, and was 0.11m deep. The pit had a steeply sloping south-west side and a more moderately sloping north-east side, falling to an irregular base (Fig. 32, Plate 30). No finds were recovered from its single charcoal-rich fill. Pit 39011 was cut by posthole 39013 toward its north-east side. This posthole had vertical sides and rounded base, almost U-shaped in profile. It measured 0.3m in diameter by 0.3m deep with a heavily charcoal-rich fill that probably indicates *in situ* burning of the post (Fig. 32, Plate 30). No finds were recovered.
- 4.11.6 **Trench 392** was located south of Trench 388 and south-west of Trench 390. This contained a single gully 39202 on an ENE-WSW alignment. It measured 0.4m wide by 0.08m deep with gently sloped sides and a rounded base (Fig. 32). No finds were recovered from its single fill. It was very similar morphologically to both gully 39007 and to ditch 39009 in Trench 390, and was on the same line as 39009, although projection of the alignment of 39007 also meets gully 39202, so may have been a continuation of either.

4.12 Trenches 365, 409, 419 and 427 (Figs 6-7, 23 and 29-32)

- 4.12.1 East and south of Land Parcel 45D only very few archaeological features were recorded in Land Parcel 45C. Deep sequences of soils including alluvial deposits and potential buried soil horizons were, however, recovered from a high proportion of the trenches, along the eastern side (Trenches 394, 397, 403, 405), across part of the north end (Trenches 400 and 406) and in a group at the south-east corner (Trenches 427, 430 and 433-435). There were hardly any finds from these sequences, mainly due to the fact that they were recorded in section following machine excavation, but a flint flake was recovered from layer 43507. The extent of alluvium revealed by the trenching corresponds closely to the low-lying areas shown on the topographic model prepared in WSI P (OA 2021, figs 4b and 4c).
- 4.12.2 Trench 365 (Figs 6 and 29) contained a single ditch aligned NW-SE. Ditch 36503 and measured 1.54m wide by 0.52m deep and had steeply sloping, slightly irregular, sides falling to an almost V-shaped base (Fig. 23). No finds were recovered from its primary fill or from its slightly charcoal-flecked secondary fill. No continuation of this ditch was seen in Trench 406 to the south-east or in the trenches in Land Parcel 45D to the north-west.
- 4.12.3 **Trench 409** lay 70m south-east of Trench 365 (Figs 6 and 29). Trenching revealed a subcircular pit 40903 measuring 0.75m by 0.85m wide and 0.24m deep with very steeply sloping sides and a flat base (Fig. 32, Plates 31 and 32). The pit had three fills, of which the primary fill (40904) contained a substantial assemblage of middle Bronze Age pottery comprising 155 sherds from a Deverel Rimbury vessel, along with 13 flint chips. Charcoal and cereal grains were also recovered from environmental sample S.111. No finds were recovered from either the secondary or final charcoal flecked fills, although charcoal and cereal grains were recovered from environmental sample S.112 of fill 40906. The assemblage recovered from this pit comprises the only evidence of middle Bronze Age activity on the wider site. Two flint fragments were also recovered during machine excavation of subsoil deposit 40901.
- 4.12.4 **Trench 419** lay south-west of Trench 409 in the northern part of Land Parcel 45C and contained a single ditch (Figs 6, 7 and 30). Ditch 41903 was aligned north-south, had sloping sides with a flat base and measured 1.38m wide by 0.2m deep (Fig. 32). No finds were recovered from its single fill. No other nearby trenches lay on its projected line; the closest was Trench 430 some 150m further south, and there was no evidence of a continuation of ditch 41903 here.
- 4.12.5 **Trench 427** lay in the south-eastern part of Land Parcel 45C, some 135m south of Trench 419, and contained a single pit (Figs 7 and 31). Pit 42703 was a broadly oval, though somewhat irregular, feature, measuring 1.75m north-south by at least 1.0m east-west, as its eastern edge lay beneath the trench edge. It was 0.28m deep with steeply sloping sides and a flat base, although its south side was more irregular, tending to the vertical nearer its base (Fig. 32, Plate 33). Its primary fill contained only a very few charcoal flecks, but the second and final fills both included more charcoal, although no finds were recovered from any of the fills. Trench 427 was only recognised at the base of

the alluvium, but it was not clear whether pit 42703 had cut the thin alluvial deposit within the trench or was sealed by it.

4.13 Trenches 441, 442, 443 and 445 (Figs 8, 33 and 35)

- 4.13.1 These trenches were part of a group located south of Land Parcel 45C at the north end of Land Parcel 45B, some of which were targeted upon several linear cropmarks on NNW-SSE and WSW-ENE alignments in this area. There were few archaeological features, but most of Trenches 436-455 contained a layer of alluvium, bearing out the LiDAR topographic model of this area in WSI P (OA 2021, figs 4b and 4c). South of this alluvium was found in Trenches 449-452 and 456, ie largely confined to the very east edge of the land parcel. It did not appear in Trenches 453-455, which sat upon a promontory of higher ground extending east into Land Parcel 48H.
- 4.13.2 **Trench 441** was targeted to cross one of two parallel linear cropmarks aligned NNW-SSE, but no trace of a ditch corresponding to the cropmark was found, and there were no other archaeological features within the trench.
- 4.13.3 **Trench 442** lay south of Trench 441 and was aligned NNW-ESE. It was also in line with the same cropmark ditch which was plotted as ending within the north end of the trench, and was also targeted upon a geophysical anomaly (Figs 8 and 33). Again no trace of a ditch corresponding to the cropmark was seen. A ditch aligned WSW-ENE was found crossing the centre of the trench, which did correspond to the geophysical anomaly. Ditch 44203 had steeply sloped, slightly irregular sides with a rounded, also slightly irregular base and measured 1.82m wide by 0.86m deep (Fig. 35, Plate 34). The only find from its single fill was a very small fragment of undated CBM.
- 4.13.4 **Trench 443** was also aligned NNW-SSE and lay east of and adjacent to Trench 442. It also contained one ENE-WSW aligned ditch (Figs 8 and 33), whose line suggests that it represents a continuation of ditch 44203. Ditch 44303 had steeply sloping sides with a rounded to flattish base and measured 1.86m wide by 0.47m deep (Fig. 35). A small, flat strip of copper alloy was recovered from the later of the two fills, but could not be dated to any particular period. These two features align well both with evidence depicted on 1st Edition OS mapping and with the linear geophysical anomaly, and represent the remains of a probably post-medieval field boundary.
- 4.13.5 **Trench 445** located c 60m north-east of Trench 443 did not contain any features of archaeological origin (Figs 8 and 33). Four sherds of late Bronze Age/early Iron Age pottery, two fragments of a fired clay loomweight also of probable Iron Age origin and a small assemblage of animal bone were, however, recovered from alluvial deposit 44505.

4.14 Trenches 448, 450 and 451 (Figs 8, 34 and 35)

- 4.14.1 These trenches lay south of Trench 445 and south-east of Trench 443, and two of them were targeted on a dog-legged linear cropmark running north-south and the turning ESE.
- 4.14.2 **Trench 448** targeted the north-south arm of the cropmark and exposed a ditch corresponding to the line of the cropmark (Figs 8 and 34). Ditch 44803 had steep, slightly rounded sides with a flat base and measured 0.89m wide by 0.31m deep (Fig. 35; Plate 35). No finds were recovered from its single fill.

- 4.14.3 **Trench 450**, which was located c 57m south-east of Trench 448, had been targeted on the ESE-WSW aligned length of the same cropmark feature. Ditch 45003 in the north end of Trench 450 was close to the line of the cropmark, although it was aligned east-west rather than WNW-ESE. This ditch had steeply sloped sides with a rounded base and measured 0.92m wide by 0.28m deep (Fig. 35, Plate 36). No finds were recovered from its single fill, although an undated iron hook was recovered from the overlying thin alluvial deposit (45001), which sealed all features in Trench 450. Ditches 44803 and 45003 are similar, and both probably confirm the cropmark evidence. Two other soilmarks (45005 and 45007) were found at this end of Trench 450, and these were tested by hand, but were judged to be of natural origin.
- 4.14.4 A larger ditch was found running east-west at the south end of Trench 450. Ditch 45008 was substantial and measured 3.26m wide by at least 1.06m deep with steeply sloping sides, almost vertical on the north side, but was not bottomed due to safety considerations. This ditch contained two recorded fills, neither of which yielded any finds (Fig. 35, Plate 37). As noted above this ditch was also sealed by a thin alluvial deposit (45001). The size of this ditch suggests it may have represented an element of a possible field boundary though it does not align with any substantial cropmark features of cartographic evidence. It does, however, align well with a faint linear geophysical anomaly.
- 4.14.5 **Trench 451** lay south of Trench 450 and contained the remains of two ditches, both sealed by alluvial layer 45104, which was 0.2m deep. Ditch 45102 was aligned east-west and had steeply sloped sides with a flat base, resulting in an almost V-shaped profile with shovel-slot base. It measured 1.08m wide by 0.56m deep and contained a single fill from which no finds were recovered (Fig. 35). This ditch was cut by a modern field drain. Ditch or gully 45105 was exposed just south of ditch 45102 and ran in a slightly sinuous course roughly north-south, turning more to the south-east along its southern extent. It had sloping sides with a rounded base and measured 0.53m wide and 0.17m deep (Fig. 35). No finds were recovered from its single fill. This feature's slightly sinuous plan could suggest it represents the remains of a drainage gully towards the lower ground in the centre of the Mar Dyke valley, but this is speculative.

4.15 Trench 452, 453, 454 and 455 (Figs 9 and 36-37)

- 4.15.1 This group of trenches lay south of Trench 451 along the eastern edge of the southern part of Land Parcel 45B, and contained a high density of archaeological features.
- 4.15.2 **Trench 452** was located c 25m SSE of Trench 451 and contained the remains of six ditches and a posthole (Figs 8-9 and 36-37, and 45205). Four of the ditches within this trench (45202, 45207, 45209 and 45215) were aligned NW-SE; of these four, ditch 45215 remained unexcavated. Ditch 45202 had steeply sloping, regular sides with a flat base and measured 1.14m wide by 0.5m deep (Fig. 37, Plate 38). It contained two fills, the upper of which was charcoal-flecked and yielded three sherds of Iron Age pottery, a few fragments of animal bone and four fragments of fired clay, one of which comprised part of a probable Iron Age oven brick or loomweight. This ditch was overlain by a thin alluvial deposit measuring 0.26m deep. Ditch 45207 lay c 5.0m north of

ditch 45202. It had very steep, slightly irregular sides with a flat, almost V-shaped base and measured 0.42m wide by 0.27m deep (Fig. 37, Plate 39). Its single fill contained ten sherds of Roman pottery, four of late Prehistoric origin, and four fragments of fired clay. Ditch 45209 lay a further 3.5m north of ditch 45207, and was similar to it, having steeply sloping, slightly irregular sides with a V-shaped base and measured 0.6m wide by 0.24m deep (Fig. 37, Plate 40). Its single, slightly charcoal-flecked fill yielded one sherd of Iron Age pottery, one of Roman pottery and three fragments of fired clay.

- 4.15.3 Ditch 45212 was located at the north end of the trench and was aligned NE-SW. It had shallow sloped sides with a slightly rounded, flattish base and measured 1.11m wide by only 0.07m deep (Fig. 37). Four fragments of fired clay and a few of animal bone were recovered from its slightly charcoal flecked single fill. It appeared to align with a faint linear geophysical anomaly, probably associated with drainage or agricultural activity. Ditch 45214 lay c 4.5m south-east of ditch 45212 and also ran on a broadly NE-SW alignment, though it curved southwards as it ran south (Fig. 36). It had steeply sloping, stepped sides with a V-shaped base, not dissimilar to NW-SE aligned ditch 45209 a little further south, and measured 0.44m wide by 0.11m deep (Fig. 37). No finds were recovered from its single fill. No continuations of either NE-SW ditch were seen in Trench 453 to the south-west, so it is possible that these features ended or returned south-eastwards, and that their returns may be represented by some of ditches 45209, 45207 or 45202. Ditch 45212 does appear to correspond to a faint geophysical anomaly, but this could not be traced very far beyond the trench, so does not assist in determining its true extent.
- 4.15.4 A single, quite substantial, posthole was also recorded south of ditch 45207 and north of ditch 45202 in the southern half of Trench 452 (Fig. 36). Posthole 45205 was subcircular in plan and measured 0.32m in diameter by 0.35m deep with vertical sides and a flat base (Fig. 37, Plate 41). Its slightly charcoal-flecked fill, which may have been deposited deliberately, contained three sherds of Iron Age pottery. This feature had also been cut by a modern field drain on its eastern edge.
- 4.15.5 **Trench 453** lay south-west of Trench 452 and contained one soilmark (45303), which was tested but determined to be of natural origin.
- 4.15.6 **Trench 455** was located south of Trench 452, and contained one probable gully, two ditches, one pit and a tree-throw hole (Figs 9 and 36). An east-west aligned gully and ditch crossed the north end of the trench, gully 45511 cut by the more substantial ditch 45506. Gully 45511 had sloping sides with a rounded base and measured 0.0.39m wide by 0.42m deep (Fig. 37, Plate 46). No finds were recovered from either of its two fills. Ditch 45506 measured 1.44m wide by 0.62m deep and had quite steeply sloping sides and a rounded, somewhat irregular base (Fig. 37, Plate 46). It contained four fills. Primary fill 45509 may have been deliberately deposited, as along with lenses and pieces of charcoal it contained quite a large assemblage of animal bone, a fragment of fired clay, which may comprise part of an Iron Age oven brick or loomweight, the tip of an iron knife and two pieces of burnt flint. No finds were recovered from its three subsequent fills.
- 4.15.7 Ditch 45504 was aligned broadly NNE-SSW and terminated within the at its south end within the trench. It had steeply sloped sides with a rounded to V-

shaped base (Fig. 37). The exposed length measured c 3.7m long and was 0.66m wide by 0.2m deep. Its single fill contained a quite substantial quantity of charcoal but no datable finds.

- 4.15.8 Pit 45502 was only evident in profile, having been recorded in the west-facing trench baulk following machine excavation. It had sloping, stepped sides and a flattish base and measured 3.4m wide by 0.4m deep (Fig. 37). No finds were recovered from its single fill. Tree-throw hole 45513 was located at the south end of the trench. It was oval in plan, measuring 0.39m wide by 0.09m deep with sloping sides and a flattish base, (Fig. 37, Plate 47). Its single fill contained two sherds of late Bronze Age/early Iron Age pottery and a fragment of fired clay or daub.
- 4.15.9 **Trench 454** was located south-west of Trench 455 and contained a cluster of six probable postholes and one ditch (Figs 9 and 36). The northernmost of the probable postholes 45402 had vertical sides with a flat base and measured 0.44m in diameter by 0.3m deep (Fig. 37, Plate 42). No finds were recovered from its charcoal-flecked fill. Posthole 45404 lay 2.5m to the south-west. It had steeply sloping sides with a flat base and measured 0.43m in diameter by 0.18m deep (Fig. 37, Plate 43). The fill was distinctly darker on the south-west side, perhaps indicating the position of a post-pipe (Plate 43). One sherd of late Bronze Age/early Iron Age pottery, one of Iron Age pottery and two fragments of fired clay were recovered from its moderately charcoal-flecked fill. Probable posthole 45412 lay c 2.5m further to the south-east. It had steeply sloping sides and a rounded, flattish base at the south-west side, with a more V-shaped form on its north-east side (Fig. 37, Plate 44). It measured 0.43m wide by 0.18m deep and one sherd of Iron Age pottery, one Roman sherd and a flint flake were recovered from its single fill. A few charcoal fragments were also recovered from environmental sample S.137. These three features could putatively represent three of the posts from a four-post structure of late Prehistoric or Roman date.
- 4.15.10 Further south lay the scant remains of probable postholes 45408 and 45410, which appeared to have been almost entirely removed by historic ploughing. Feature 45408 had an irregular shape, measured 0.38m by 0.23m and was only 0.03m deep in plan, with very shallow sides and a flattish, irregular base (Fig. 37). A single fragment of fired clay was recovered from its single fill, and a few charcoal fragments were also recovered from environmental sample S.125. Feature 45410, c 4.5m to the south-east, was broadly circular in plan, measuring 0.38m in diameter, and somewhat more convincing as the remains of a posthole, although it survived only 0.02m deep with shallow sloping sides and a flat, slightly irregular base (Fig. 37). No finds were recovered from its single fill. Probable posthole 45406 lay at the south end of the cluster, c 2.5m south of feature 45408. This had steeply sloping sides tapering to an almost pointed base and measured only 0.18m wide by 0.09m deep (Fig. 37, Plate 45). No finds were recovered from its single fill.
- 4.15.11 A single ditch (45416) was located at the southern end of the trench and was aligned east-west. It had steeply sloped sides and a flat base and measured 2.64m wide by 0.62m deep (Fig. 37). No finds were recovered from its single fill.

4.16 Trenches 457, 459, 460, 461, 462, 463 and 464 (Figs 10, 38-39 and 41)

- 4.16.1 This group of trenches were found in the north-west part of Land Parcel 46. Other than the features in Trench 460, which contained a variety of types of feature, and will be described last, all of the features were ditches aligned NNW-SSE, and all were similar in terms of profile and fills. Six of these ditches (45703, 45705, 46103, 46106, 46203 and 46402) were excavated.
- 4.16.2 **Trench 457** contained two ditches spaced 17m apart. Ditches 45703 and 45705 each had very steep, almost vertical sides with a flat base. They measured 0.61m and 0.78m wide by 0.54m and 0.57m deep respectively (Fig. 41, Plates 48 and 49). Seven flint flakes or chips were recovered from the fill of ditch 45703, along with charcoal fragments and several cereal grains from environmental sample S.116. Two sherds of Roman pottery, along with two flint flakes were recovered from the fill of ditch 45705, again along with charcoal fragments and several cereal grains from environmental sample S.118. Both fills appeared to have been deliberately deposited.
- 4.16.3 **Trench 459** was aligned parallel to Trench 457 some 13m to the north, and contained continuations of the same two ditches, here numbered respectively 45903 and 45905, neither of which was excavated.
- 4.16.4 **Trench 462** was located c 44m south-east of Trench 457 (Fig. 38) Two parallel ditches were recorded (46202 and 46203) c 10.5m apart, of which only ditch 46203 was excavated. Like the examples in Trench 457, ditch 46203 had very steep, almost vertical sides, and measured 0.85m wide by at least 0.59m deep, but was not bottomed due to the depth of the trench (Fig. 41, Plate 51). The ditch contained a single deliberately deposited fill from which three burnt flint fragments were recovered, along with one sherd of late Iron Age/early Roman pottery and three sherds of Roman pottery including a sherd of 1st-2nd century Samian ware.
- 4.16.5 **Trench 461** was located north-east of Trench 461 and east of Trench 459 (Fig. 39). It contained three ditches (46103, 46105 and 46106) from east to west, spaced 10m-11m apart. Ditch 46105 remained unexcavated. Ditch 46103 measured 0.62m wide and 0.44m deep with almost vertical sides rounding to a flattish base, whilst ditch 46106 measured 0.66m wide with vertical sides, though sloping out at the top of the west side, and was at least 0.48m deep but was not bottomed (Fig. 41). No finds were recovered from the fill of ditch 46103 and only a few charcoal fragments from environmental sample S.117. Five sherds of pottery, one each of late Prehistoric and late Iron Age/Roman and three of Roman origin, along with two flint flakes, were recovered from the fill of ditch 46106, along with a few charcoal fragments from environmental sample S.138 (Fig. 41, Plate 50). Both fills appeared to have been deliberately deposited.
- 4.16.6 **Trench 463** contained a continuation of ditch 46103 in its western edge, which was not excavated.
- 4.16.7 Trench 464 was located south-east of Trench 461 and c 64m ENE of Trench 462. Two parallel ditches lying c 10.5m apart were recorded (46402 and 46405), of which only ditch 46402 was excavated. Ditch 46402 had very steeply sloping sides with a flat base and measured 0.59m wide by 0.32m

deep (Fig. 41). No finds were recovered from its single deliberately deposited fill and environmental sample S.140 contained only a few fragments of charcoal

- 4.16.8 The similar profiles and regular spacing of these ditches, together with the deliberate infilling, strongly suggests that they were all contemporary, and probably of Roman date. Groups of similar linear features, whose dating was again small quantities of Roman pottery, were found in land parcels 21 and 48B and C on the south side of the Mar Dyke valley (OCA 2020b; OCA 2021a), suggesting a common cultivation practice in both areas during the Roman period.
- 4.16.9 **Trench 460** was also located in the north-west of Land Parcel 46, east of Trench 459 and west of Trench 461 (Fig. 10). A dense cluster of features was identified in the northern half of the trench, which comprised the remains of a probable hearth, a large irregular-shaped pit, two ditches and a probable occupation deposit (Fig. 38). The possible hearth (46003) was located at the southern end of this cluster of features on the west side of the trench, and was not fully exposed. It measured 2.65m along its NNW-SSE axis by 1.65m on its ENE-WSW axis and was 0.26m deep with steeply sloping sides with a flattish, slightly irregular base. Its base and sides displayed evidence of *in situ* burning, and there was a small quantity of charcoal-flecking within its single, possibly deliberately deposited fill, from which a few charcoal fragments were extracted in environmental sample S.142. Some 68 fragments of fired clay were recovered from this fill (Fig. 41, Plate 52), but no datable finds.
- 4.16.10 A large, elongated pit (46005) was partly exposed on the east side of the trench slightly further to the north-east. It measured 2.1m long on its NNW-SSE axis by 0.5m ENE-WSW (the rest being outside the trench) and was 0.62m deep with a steeply sloping western side, a stepped, sloping eastern side and a rounded, slightly irregular base (Fig. 41, Plate 53). The pit contained three fills and a small assemblage of late Bronze Age/early Iron Age pottery was labelled as coming from the primary fill 46010, but the context sheet says that there were no finds, so this is probably a misnumbering for the fill of later ditch 46013 (see below). Nothing came from the two other fills. An environmental sample S.151 was taken of the final fill 46012, and produced a small quantity of charcoal fragments.
- 4.16.11 Pit 46005 was cut on its north-west edge by a slightly curvilinear ditch (46007). Approximately 5.6m of the ditch was exposed running on a broadly NNW-SSE alignment along the length of the trench. Three interventions were dug along it, in which it was numbered 46007, 46015 and 46021. These demonstrated that the ditch had moderately steep sides and a flattish base, measuring c 1.3m wide by c 0.5m deep (Fig. 41, Plates 54-55). Ditch intervention 46007 contained two fills. No finds were recovered from its primary fill; the upper fill (46009) was charcoal-rich and had been deliberately deposited, containing a sizeable assemblage of fired clay fragments including some daub, together with 15 sherds of late Bronze Age/early Iron Age pottery, two flint flakes and two blades. A large quantity of charcoal fragments was also recovered from environmental sample S.150. The two blades are probably of Mesolithic or early Neolithic date and were probably redeposited. Fill 46009 also contained a moderate assemblage of cremated bones from at least one human adult.

These comprised elements of the upper and lower long bones and cranial fragments. Ditch intervention 46015 contained three fills (Fig. 41, Plates 55-56). One sherd of late Bronze Age/early Iron Age pottery, a small assemblage of fired clay fragments and two flint flakes were recovered from its secondary, deliberately deposited fill (46017). The third intervention (46021) through this ditch contained a single fill, from which no finds were recovered (Fig. 41). Because of the quantity and variety of material found, this ditch could potentially represent part of a late Bronze Age or early Iron Age enclosure.

- 4.16.12 Ditch 46013 was partially exposed crossing the very north end of the trench, was aligned ENE-WSW and cut curvilinear ditch 46007/46015/46021. It had a very steeply sloping south side and a flat base, and measured at least 0.6m wide by 0.44m deep (Fig. 41, Plate 56). The context records say that the fill included Bronze Age pottery, but none labelled 46014 were processed. It is probable that a small assemblage of LBA-EIA sherds labelled as 46010 were misnumbered, as no finds were noted as coming from this context. If so, the pottery may well have been redeposited from ditch 46015 that was cut by ditch 46013, rather than dating ditch 46013 itself.
- 4.16.13 Possible occupation deposit 46019/46020 was partially exposed in the west half of the trench and measured at least 1.25m wide on its ENE-WSW axis by c 4.65m long NNW-SSE axis. It was 0.26m deep where exposed and was cut by both curvilinear ditch 46007/46015/46021 and ditch 46013 (Fig. 41, Plate 57), and continued for some distance on both sides of the ditch (Fig. 41, section 46004). No finds other than four fragments of fired clay were recovered from this layer, but it must be of late Bronze Age or earlier date.

4.17 Trench 466 (Figs 10-11, 40 and 41)

- 4.17.1 Trench 466 was located within a group of trenches east of Trenches 461 and 464 in a separate field at the north-east end of Land Parcel 46. Very few archaeological features were found in this area, but Trench 466 contained two ditch termini aligned ENE-WSW (Figs 10 and 40). The eastern terminus of ditch 46602, which lay in the northern half of the trench, had near vertical sides with a flat base and measured 0.53m wide axis by 0.47m deep (Fig. 41, Plate 58). One sherd of Roman pottery was recovered from its single fill. The eastern terminal of a second probable ditch was found 11.3m to the south. Ditch 46605 had steeply sloping sides with a pointed base and measured 0.5m wide and 0.4m deep (Fig. 41). No finds were recovered from its deliberately deposited fill.

4.18 Trench 482 (Figs 10-11, 42 and 46)

- 4.18.1 Trench 482 was also within the trenches in the north-eastern part of Land Parcel 46, and lay 150m south-east of Trench 466, where it was targeted upon a linear cropmark aligned NNW-SSE, part of a system of field boundaries and a probable rectilinear enclosure (Fig. 10). This was the only trench to target the cropmarks. Archaeological remains in the trench comprised three ditches, all aligned broadly NNW-SSE, and one probable ditch terminus (Fig. 42).
- 4.18.2 Ditch 48210 lay toward the west end of the trench and corresponded to the line of the targeted linear cropmark. It measured 1.7m wide by 0.52m deep and had sloping sides and a flat base (Fig. 46, Plate 59). There was one

charcoal-flecked fill that produced only a single flint chip; this came from environmental sample S.141, which also contained a very small quantity of charcoal fragments.

- 4.18.3 Ditch 48208 lay 2m east of ditch 48210, and parallel ditch 48203 c 10.5m further east. These two ditches both had vertical or near-vertical sides and a flattish, but slightly uneven, base and measured 0.58m and 0.50m wide respectively, and were both 0.54m deep (Fig. 46). Both ditches had single fills of mottled clay with a little charcoal, whose mixed character suggested that they may have been deliberately deposited. No finds were recovered from either.
- 4.18.4 Ditch terminus 48205 had near-vertical sides and a slightly sloping flattish base and measured 0.5m wide by up to 0.48m deep (Fig. 46). No finds were recovered from either of its two fills.
- 4.18.5 Despite the absence of finds, the profile, fill and spacing of parallel ditches 48203 and 48208 makes them similar to the Roman ditches found in the same land parcel further west, together with the parallel larger cropmark boundaries, could represent elements of a Roman agricultural system like those found elsewhere across the Mar Dyke valley sides.

4.19 Trenches 487, 488, 492, 493, 494, 502 and 505 (Figs 11 and 43-47)

- 4.19.1 These trenches were located in the southern half of Land Parcel 46, and south-west of the linear cropmark investigated in Trench 482. Five more ditches aligned NNW-SSE were found in these trenches, together with four ENE-WSW ditches or gullies, two N-S ditches and an ENE-WSW ditch terminal.
- 4.19.2 **Trench 487** contained two ditches aligned NNW-SSE. Ditch 48705 lay in the east part of the trench, and was 11m (centre to centre) from parallel ditch 48707 to the west, which was not excavated. Ditch 48705 was truncated by recut 48703 at the top, but had very steep to vertical lower sides and a V-shaped base and had originally been 0.55m deep (Fig. 46, Plate 60). No finds were recovered from its single slightly charcoal-flecked fill. Recut ditch 48703 had one sloping and one vertical side and a flat base and measured 1.23m wide by 0.29m deep. One sherd of late Iron Age/Roman pottery and one of Roman date were recovered from its slightly charcoal-flecked fill. No continuation of ditch 48705 was seen in Trench 499 to the south.
- 4.19.3 **Trench 488** lay east of Trench 487, and contained a single ditch on a NNW-SSE alignment. Ditch 48803 was located c 32m east of ditch 48703. It had almost vertical sides with a flat base and measured 0.87m wide by 0.3m deep (Fig. 46). No finds were recovered from its mottled, slightly charcoal-flecked clay fill. This ditch had a very similar profile to others described above, which have been interpreted as probable Roman period cultivation ditches, and was also in line with ditch 48203 to the north.
- 4.19.4 **Trench 492** lay south-west of Trench 487, and contained a single ditch on a NNW-SSE alignment. The ditch was much wider on the south (numbered 49203) than the north (numbered 49205), so it was assumed that the ditch must have been recut, but only one fill was found across the wider feature,

and no trace of two cuts, so it is probable that the drawn intervention shows only the wider recut (49203) on the south. This had a steeply sloping side on the west and a near-vertical side on the east, and a slightly irregular flattish base (Fig. 47). The recut measured 0.9m wide by 0.28m deep (Fig. 47). No finds were recovered from its single, slightly charcoal-flecked fill. No continuation on the line of this ditch was seen in Trench 503 to the south.

- 4.19.5 **Trench 494** lay south of Trench 488 and south-east of Trench 487. It contained two ditches and a probable pit or ditch terminus (Fig. 43). Ditch 49403 measured 0.78m wide by at least 0.5m deep with very steep, almost vertical sides, but was not bottomed due to the trench depth (Fig. 47). It contained two fills, and one sherd of Roman pottery was recovered from 49405, the deliberately redeposited upper fill. Unexcavated parallel ditch 49406 was located c 10.5m to the east of ditch 49403, and may have been associated. Ditch 49406 had an uncertain relationship with a wider pit or ditch terminus protruding from the southern edge of the trench, which also remained unexcavated.
- 4.19.6 The projected line of ditch 49406 lies 10-11m east of ditch 48703, and it is possible that the parallel ditches in both trenches were part of a regularly spaced series. This could potentially also have included the parallel ditches in Trenches 492 to the west and 488 to the east, although no continuation of ditch 48803 was seen crossing the eastern part of Trench 494. The absence of continuations of any of these ditches in the trenches to the south, except possibly for unexcavated ditch 49406, indicates that, whatever their function, they were of limited extent.
- 4.19.7 **Trench 493** was located between Trench 459 and Trench 461, and contained four ENE-WSW ditches or gullies, the most northerly two of which (49307 and 49308) were not excavated. These lay 2.3m apart and both terminated within the trench, although ditch 49308 appeared to have two termini with a gap 0.7m wide between them. Ditch terminus 49305 lay just over 2m further south, and had steep sides with a rounded base (Fig. 47, Plate 61). It measured 0.65m wide by 0.11m deep and contained one slightly charcoal-flecked fill from which three sherds of Iron Age pottery were recovered. Ditch or gully 49303 lay 7.5m further south, had steep sides with a rounded base and measured 0.55m wide by 0.13m deep (Fig. 47). No finds were recovered from its single fill. These ditches or gullies are perpendicular to the NNW-SSE cultivation ditches already discussed. No continuation of either ditch 49307 or 49309 was seen in Trench 488 to the north-east.
- 4.19.8 **Trench 489** was located in the south-west of Land Parcel 46 on the west edge, some 90m west of Trench 492, and revealed an ESE-WNW aligned ditch terminus and a north-south aligned ditch at its south end (Figs 11 and 44). Ditch terminus 48903 had steeply sloping sides with a flattish, slightly irregular base and measured 0.55m wide by 0.3m deep (Fig. 47). It contained three fills, all of which were charcoal-flecked, the middle fill notably more so than the primary and final fills. No finds were recovered from any of these. Ditch 48907 lay just to the east of terminus 48903 and was partially exposed in the east side of the trench. It had quite irregular sides with a flattish base and measured at least 0.43m wide by 0.18m deep (Fig. 47). No finds were recovered from its

single fill. No continuation on the projected line of this ditch was seen in Trench 483 to the north.

- 4.19.9 **Trench 502** was located c 39m south-west of Trench 493 and contained a single ditch aligned ENE-WSW (Figs 11 and 44). Ditch 50203 also had steep sides and a rounded base, but was 0.85m wide and only 0.17m deep (Fig. 47). No finds were recovered from its single fill.
- 4.19.10 The ENE-WSW ditches and gullies may, putatively, be part of the same wider network of cultivation and drainage ditches as those on a NNW-SSE alignment, though the few sherds of Iron Age pottery could suggest an earlier and unrelated agricultural function.
- 4.19.11 **Trench 505** was located in the south-east corner of Land Parcel 46, 70m south of Trench 494 and c 95m east of Trench 502. It contained one ditch aligned N-S (Figs 11 and 45). Ditch 50503 had steep sides with a rounded base and measured 1.15m wide by 0.4m deep (Fig. 47). Its single fill contained a large quantity of charcoal, including some large pieces, as well as a small quantity of charred cereal grains (sample S.115). No finds were recovered from it, however. The projected line of this ditch is close to the unexcavated pit or ditch terminal in Trench 494, but as so little of this was revealed, a link between them can only be speculative.

4.20 Trenches 514, 520, 521, 523, 525 and 528 (Figs 12-13, 48, 49 and 51)

- 4.20.1 These trenches were all located in the north-east part of Land Parcel 43 (Fig. 12) and contained a group of ditches on either NNW-SSE or WSW-ENE alignments, together with a single pit (Figs 12 and 48-49).
- 4.20.2 **Trench 514** was targeted upon a pair of possibly archaeological geophysical anomalies towards its west end, and proved contained a single ditch on a NNW-SSE alignment, but not on the line of the supposed anomalies (Fig. 48). Ditch 51403 measured 0.83m wide by 0.22m deep and had steeply sloping, slightly irregular sides and a rounded base (Fig. 51). A single fragment of post-medieval to modern tile was recovered from the fill of ditch 51403.
- 4.20.3 **Trench 516** lay east of Trench 514 and north of Trench 523. A possible hearth or tree throw was partially exposed on the northern side of the trench (Figs 12 and 49). Feature 51603 had sloping, quite irregular sides with a slightly stepped to flattish base (Fig. 51, Plate 62). It measured 1.75m wide on its ENE-WSW axis and at least 0.75m on its NNW-SSE axis and was 0.45m deep. The base of the feature was reddened in the centre, probable evidence of burning *in situ*. It contained four fills from which no finds were recovered. Moderate quantities of charcoal were evident in its second and third fills, but environmental samples from these fills (S.89 and S.90 respectively) did not contain any other remains of significance.
- 4.20.4 **Trench 519** lay at the west end of the group of trenches in the north-east part of Land Parcel 43, and was in part targeted upon an ENE-WSW aligned former field boundary depicted on 1st Edition OS mapping and evident in the results of the geophysical survey. Trench 519 contained two ditches on an ENE-WSW alignment, only the more northerly of which was excavated. Ditch 51904 had almost vertical sides rounding off to a flattish, slightly irregular base and

measured 0.78m wide by 0.32m (Fig. 51, Plate 64). Its single charcoal flecked fill yielded three sherds of late Bronze Age/early Iron Age pottery and a charred stinking chamomile seed (sample S.88). Ditch 51903 was found further south, and only 2m offset from the plotted line of the post-medieval field boundary (Fig. 48), so probably corresponds to this, but was not excavated.

- 4.20.5 **Trench 520** lay east of Trench 519 and contained a single ditch that ran along the trench on a WSW-ENE alignment for 16.5m with a somewhat irregular outline in plan, and appeared to terminate before the west end of the trench. Ditch 52003 measured 0.77m wide by only 0.12m deep with gently sloping sides and a flat base (Fig. 51). No finds were recovered from its single fill, although a moderate quantity of charcoal fragments and a charred oat/brome grass seed were recovered (sample S.87). This ditch probably continued as ditch 52103 in Trench 521 to the east.
- 4.20.6 **Trench 521** lay east of Trench 520, and revealed three ditches on a WSW-ENE alignment. Ditch 52103 was on the same line as ditch 52003, and is clearly a continuation, although it had a slightly different profile, with moderately steep sides and a flat base, and measured 0.52m wide by 0.21m deep (Fig. 51, Plate 65). Two sherds of late Bronze Age/early Iron Age pottery were recovered from its single deliberately deposited fill along with a small quantity of hulled wheat grains and glume fragments (sample S.92). Ditch 52105 lay c 12m NNW of ditch 52103 on the same alignment. It had steeply sloping sides with a flat base and measured 0.72m wide by 0.3m deep (Fig. 51). Five sherds of Iron Age pottery were recovered from its single fill.
- 4.20.7 As with the ENE-WSW ditches in Trench 393 described above, these ditches yielded small quantities of prehistoric pottery, which could suggest a pre-Roman period agricultural function, although the quantity of material is very small, and they may instead be related to the Roman ditches on a perpendicular alignment, or even be considerably later, and associated with the post-medieval field boundaries on the same alignment.
- 4.20.8 The third ditch was 52102, which lay 3m south of the post-medieval OS field boundary and was in line with ditch 51903 to the west, and of similar width, but was not excavated. It was, however, also in line with wider ditch 52602 only 20m to the east, which contained post-medieval/modern finds, and confirms the correspondence of these ditches to the historic field boundary.
- 4.20.9 **Trench 526** lay east of Trench 521, and contained a single ditch orientated WSW-ENE (Fig. 48). Ditch 52602 lay 4m south of the plotted OS historic field boundary, and was excavated. It measured 2.5m wide by 0.68m deep with sloping sides and a rounded, slightly irregular base (Fig. 51, Plate 63). Four fragments of post-medieval to modern tile and a small residual sherd of late Bronze Age/early Iron Age pottery were recovered from its single deliberately deposited fill. The ditch was wider here than in either Trenches 519 or 521 to the west or Trenches 523 and 525 to the east, and as it contained a residual prehistoric sherd, may perhaps have incorporated an earlier ditch like those in Trench 521 within it.
- 4.20.10 **Trench 523** lay east of Trench 526, and revealed a single ditch on a WSW-ENE alignment at its south end, some 5m south of the plotted historic OS boundary. The ditch was not excavated, but was around 1.6m wide, similar to ditches 51903 and 52102 further west.

- 4.20.11 **Trench 525** lay at the east edge of Land Parcel 43 and east of Trench 523, and also exposed one ditch aligned WSW-ENE at the south end. This was not excavated, but was on the same line as ditch 52303 to the west, and although it was offset from the plotted OS boundary by nearly 6m, is almost certainly a continuation of the same historic post-medieval field boundary.
- 4.20.12 **Trench 528** lay south of Trench 523 and contained a single ditch. Ditch 52803 had steeply sloping sides and a rounded base and measured 0.97m wide by 0.2m deep (Fig. 51). No finds were recovered from its single fill.
- 4.20.13 **Trench 527** lay south-east of Trench 526, and contained a sub-circular soilmark (Figs 12 and 48). Feature 52703 was investigated by hand, and proved to be of natural origin although the soil did contain small quantity of charcoal.

4.21 Trench 534 (Figs 12 and 50-51)

- 4.21.1 **Trench 534** was located in a group of trenches on the south-western corner of Land Parcel 43, and was the only trench to contain archaeological features (Figs 13 and 50). The trench contained two small pits or postholes that lay adjacent to one another, and were numbered 53403 and 53405. These two features each had gently sloped sides with a rounded, to flat base and measured 0.24m and 0.26m in diameter by 0.04m and 0.06m deep respectively (Fig. 51). They appeared to have been quite badly truncated and no finds were recovered from either of their single fills.

4.22 Finds summary

- 4.22.1 **Pottery.** A total of 366 sherds (4005g) of pottery were recovered from the evaluation. The pottery was in moderately poor condition with surfaces and fractures exhibiting signs of heavy wear. It provides evidence of activity within the site and its vicinity spanning the middle Bronze Age to Roman periods and the medieval period.
- 4.22.2 A large assemblage of sherds from fill 40904 of pit 40903 in Trench 409 belonging to a Deverel-Rimbury vessel provides some evidence for non-funerary activity during the middle Bronze Age. Due to its poor condition and scarcity of diagnostic features, much of the remaining prehistoric assemblage could be dated only broadly, although late Bronze Age to early Iron Age and middle Iron Age elements appear to be present. The late Iron Age to Roman assemblage provided some evidence for activity dating to the ‘transitional’ period (1st centuries BC/AD). Most material, however, could only be dated as Roman.
- 4.22.3 The medieval group (dating to the 11th – 15th centuries) is typical of assemblages of this broad date range in this part of Essex. The early medieval wares were in relatively coarse, largely oxidised fabrics comparable with those found across much of Essex. The high medieval sherds were probably made in south Essex or possibly Kent.
- 4.22.4 **Ceramic building material.** A total of only 11 fragments of ceramic building material weighing 153g were recovered from the evaluation. The assemblage was highly fragmented. Some tiles dating to the post-medieval to modern period were identified, with the remainder of the assemblage comprising pieces of indeterminate form, which were not closely dateable.

- 4.22.5 **Fired clay.** A total of 167 fragments (1398g) of fired clay were recovered. The assemblage was poorly preserved, and the majority of fragments did not exhibit any diagnostic features. Three fragments may represent fragments of triangular loomweights or oven bricks. Six other fragments preserved flat surfaces or round-sectioned, probable wattle impressions and may represent fragments of burnt daub from ovens or buildings.
- 4.22.6 **Worked flint.** A small assemblage of 46 worked flints (207g) and 20 pieces of burnt, unworked flint (442g) was recovered. Thirteen chips were associated with pottery of middle Bronze Age date. A further eight flints were recorded with flint-tempered pottery of probable late Bronze Age/early Iron Age date, including two blades. The two blades are probably of Mesolithic or early Neolithic date.
- 4.22.7 **Metalwork.** Six fragments of metalwork (239g) were recovered, comprising two fragments of iron nails, a fragment of late medieval iron horseshoe, a hook-shaped fragment of iron, an iron knife tip and a flat strip of copper alloy.

4.23 Environmental summary

- 4.23.1 **Charred plant remains.** Twenty two samples were taken and assessed, primarily for charred plant remains. The only mode of preservation evident in the sampled contexts and features was charring, with the quantity and quality of the charred remains being relatively low. Samples 91, 111, 115, 125, and 150 produced the greatest quantities of charcoal and Sample 94 contained the largest number of cereal grains and weed seeds. Further identification of the cereal grains and weed species present was not undertaken at assessment stage, but the material was sufficiently well-preserved to make this possible in future.
- 4.23.2 **Human bone.** Burnt bone comprising fragments of femur, tibia, ulna and radial shaft and cranial vault fragments were recovered from Trench 460, from ditch fill 46009 that also contained late Bronze Age/early Iron Age pottery.
- 4.23.3 **Animal bone.** Animal bone amounting to 88 fragments (813g) were recovered via hand excavation and the processing of bulk soil samples. The material was highly fragmented and only moderately well preserved, a combination of factors resulting in 78% of the assemblage being unidentifiable to species level. There was very limited direct association with datable material, but those artefacts recovered dated broadly to the late Bronze Age to the early Iron Age.

5 Discussion

5.1 Reliability of field investigation

- 5.1.1 The archaeological features were reasonably well defined against the underlying London Clay and Head deposits, especially since the majority cut through the Head deposits rather than directly through the London Clay. Several natural features were also sample excavated to establish whether or not they were of geological or archaeological significance. Due to the length of time in the field there was a good mix of wet and dry weather, but wet weather was increasingly a problem towards the end of the programme of work. The evaluation of Land Parcels 43 and 45D were undertaken during predominantly dry periods, but the evaluation of Land Parcels 45B, C and E and Land Parcel 46 experienced several significant downpours that lead to widespread flooding of trenches and the surrounding fields. As a result, there were also instances where there was surface water movement across these land parcels. Overall, the weather had a minimal impact on the accuracy and reliability of the investigation since archaeological remains were identified during initial stripping and were predominantly evaluated prior to being flooded. There was some constraint in Land Parcel 46 where trenches continued to suffer water ingress despite continual pumping. Several trenches in this land parcel were subsequently re-stripped to ensure accuracy of recording and interpretation.
- 5.1.2 With the exception of Trenches 282-296 and 298-302, which were removed from the scope of works following consultation with the Client and the Historic Environment Consultants for Place Services, Essex County Council, all trenches set out within the WSI were excavated. Several trenches were not laid out on a standard grid but adjusted on site slightly to account for the exclusion zone associated the High-Pressure gas pipeline in Land Parcels 45A-C and for the exclusion zone on Land Parcel 45D. In some trenches during initial machine excavation it proved quite difficult to discern the interface between subsoil and alluvial deposits and underlying Head deposits. This was mitigated through an ongoing review of the activity to adjust the depth of excavation accordingly when the interface was identified. Despite this there remains a possibility that additional archaeological remains were not identified, but on balance, the potential for this is low.
- 5.1.3 Several features were not fully excavated as they extended below the safe working depth of 1m below ground level. However, the depths of these features can be confidently extrapolated based on the predictable profiles of any such features, limiting the impact of this factor.
- 5.1.4 There was reasonable correlation between the aerial survey cropmarks, the geophysical survey results and archaeological features in most the trenches. Recorded cropmark evidence comprised the remains of one probable enclosure of medieval date, identified in Trenches 374 and 375 and elements of two undated examples in Trenches 448 and 450 and in Trench 482 respectively. Elsewhere cropmark and geophysical survey evidence of former historic field boundaries was identified in Trenches 442, 443, 519, 521, 523, 525 and 526. The results of the geophysical survey principally identified field

drainage, former historic field boundaries and agricultural anomalies, a possible pond or natural depression in Trench 341 and probable ferrous/debris spreads. With these exceptions, all other recorded features, comprising ditches, gullies, pits, tree throws and postholes were not evident in these sources. Where cropmarks were not evident following the opening of trenches it is likely any physical evidence had been either ploughed away or was the result of inaccurate mapping.

- 5.1.5 Archaeological features were quite sparsely distributed throughout the site and where these were present were either naturally infilled with the deposits into which they were dug or deliberately infilled with the same very localised deposits. It is this factor and the typically quite shallow depth of most features – commonly less than 0.5m – that probably resulted in the occasional disparity with cropmark evidence and the invisibility of the features in the geophysical survey results. Shallow cut ditches, gullies, small pits and postholes are typically not identified on the prevailing geology or as cropmarks.
- 5.1.6 On balance, whilst the overall density of archaeological remains within the site was slightly underrepresented by the cropmark evidence and geophysical survey results this had no measurable impact on the reliability of the evaluation.
- 5.1.7 Archaeological remains across the site were generally truncated by ploughing, although the features were mostly preserved to a reasonable depth. As noted above also, occasional difficulty in defining the interface between subsoil, alluvial deposits and Head deposits in places and the occasions where re-stripping was necessary may have resulted in slight over-machining of deposits. This may have further truncated the uppermost elements of certain individual features. Despite this, the types, morphology, distribution and preservation of archaeological features that were identified across the site was sufficient to enable a confident interpretation of the results. It is unlikely that historic truncation or any potential over-machining will have otherwise influenced the preservation of remains.

5.2 Interpretation

- 5.2.1 **Mesolithic/Neolithic.** Early prehistoric evidence was limited to a small assemblage of flints. Specifically, these comprised two blades of either Mesolithic or early Neolithic date from fill 46009 of ditch 46007. The remaining flints were not chronologically diagnostic beyond a general prehistoric date.
- 5.2.2 The occurrence of these artefacts in such a small quantity suggests that activity during this period was little more than transitory. This is consistent with the limited previously recorded evidence within the vicinity, but a greater level of activity has recently been found by evaluation in Land Parcel 48H on the east side of the Mar Dyke river (OCA 2020a, OCA 2020b; OCA 2022 forthcoming), with which the activity in this area may be associated.
- 5.2.3 **Middle Bronze Age.** A large assemblage of sherds from a single bucket shaped jar in the Deverel Rimbury tradition was recovered from pit 40903 at the east end of Trench 409 in Land Parcel 45C. The pit also produced some charred barley, suggesting that domestic activity was taking place nearby. Although the deposit appears deliberate, perhaps as a dump of material, the event appears to have been an isolated example. Despite this, it does suggest

that non-funerary activity was taking place in the wider area during this period; middle Bronze Age settlement is often scattered, so does not rule out the presence of further pits or other features within this area.

- 5.2.4 **Late Bronze Age/early Iron Age and middle to late Iron Age.** The greatest concentration of material of late Bronze Age or early Iron Age date was found in Land Parcel 46 in Trench 460. Here ditch 46007 contained both pottery, fired clay, struck flint, charcoal and cremated human bone, and may have had a hearth or fire pit adjacent. This may indicate the pyre site and subsequent deposition of a burial in the ditch, which is not unusual for the period, but the presence of fired clay and struck flint suggests either burial accompanied by ancillary activities or, more likely, domestic and burial activity adjacent to the ditch, which may have belonged to an enclosure. The soil into which these features were cut also contained fired clay, and was interpreted on site as an earlier occupation deposit, although it is alternatively possible that this was the result of mixing of occupation either side of the ditch into the underlying soil by worm action. Struck flints from this site were few, but flakes were found not only in Trench 460 but also in Trenches 457, and both a flint flake and a sherd of late Bronze Age/early Iron Age pottery in Trench 461, suggesting a wider area of associated activity in the vicinity. This activity area lies 450m east of the late Bronze Age features found during construction of the Horndon to Barking gas pipeline.
- 5.2.5 A second focus of later prehistoric activity is probably indicated by the postholes, ditches, a pit and a tree-throw hole in Trenches 452, 454 and 455, associated with later prehistoric pottery and (in Trench 454) struck flint, all in Land Parcel 45B. One of the ditches also included part of an oven brick or loomweight of characteristically Iron Age form. Three postholes were tentatively interpreted as part of a four-post structure, although the dating of this is complicated by the presence of a Roman sherd within one of the postholes, and within one of the ditches. The pottery is also divided between flint-tempered fabrics, more commonly found in the late Bronze Age/early Iron Age and sandy fabrics, which, especially the glauconitic sand, is generally seen as of middle to late Iron Age date. The survival of flint-tempered fabrics into the middle Iron Age is however well-attested in Essex and north Kent, and the date for this activity may therefore lie in the middle Iron Age. It remains unclear how many of the excavated features were Iron Age rather than Roman, and it is probable that there was a mixture of activity of both periods in this area.
- 5.2.6 In Trenches 519 and 521 within Land Parcel 43 several small ditches on a WSW-ENE alignment contained flint-tempered or sand-tempered sherds of later prehistoric date, and another sherd was recovered in a residual context in Trench 526. The survival of flint-tempered fabrics into the middle Iron Age has already been mentioned, so these probably indicate a small area of middle Iron Age activity here. This may have been focussed on the parallel ditches, perhaps indicating some form of cultivation, or may have been derived from surface activity in the adjacent area. This area of activity lies 250m north-west of the later prehistoric features found during construction of the Horndon to Barking gas pipeline (OA 2021, fig. 6, gazetteer number 380).

- 5.2.7 A group of four postholes in Trench 311, three in line, and a ditch that crossed this trench and Trench 306 adjacent, suggest a further area of Iron Age activity in Land Parcel 45E. Most of these features contained Iron Age pottery, and the ditch also contained flint flakes, but as with the postholes in Trench 454, one posthole also contained Roman pottery, throwing a little doubt on the date of origin of the posthole structure, but it remains likely that a focus of Iron Age activity is present in the vicinity of these trenches.
- 5.2.8 In Land Parcel 45B, four sherds of late Bronze Age/early Iron Age pottery, a fragment of a probable triangular oven brick or loomweight of characteristically Iron Age form and a fragment of daub were recovered from an alluvial deposit in Trench 445, which was otherwise archaeologically sterile. This material may have been washed in, but may alternatively represent surface activity on the floodplain. The surrounding linear cropmarks were shown by the evaluation to be genuine, but apart from a single flint chip, did not provide any artefacts, so remain undated. It is possible, however, that the finds from Trench 445 were associated, and that the cropmarks were later prehistoric.
- 5.2.9 It is noticeable that the potential foci of activity of this period in Land Parcels 43, 45E, 46 and 45B were all found in trenches on the edge of the evaluated areas, and the relatively low level of material recovered may not therefore reflect the character of later prehistoric activity in these areas, the focus of which may extend into the adjacent unevaluated areas. The results of the evaluation suggest that activity of both late Bronze Age/early Iron Age and middle Iron Age date is present within the lower slopes of the Mar Dyke valley, including several foci of the later Iron Age.
- 5.2.10 **Late Iron Age and Roman.** Only a small assemblage of pottery (23 sherds) consisting largely of undiagnostic body sherds was recovered from the site, and of these, only nine sherds from Trenches 375, 376, 462 and 487 that were of late Iron Age/early Roman date could be dated within the Roman period. All were small, and there were no large groups of sherds, indicating that the site lies at some distance from any focus of settlement, the sherds probably finding their way onto the site by means of rubbish disposal and manuring.
- 5.2.11 Dated Roman features principally comprised quite narrow, shallow ditches, generally of a specific character with vertical or near-vertical sides, flat bases and mixed fills indicating deliberate deposition. Undated ditches of similarly diagnostic character in the same or adjacent trenches could therefore confidently be associated with the dated examples. In several areas of the site, notably within Land Parcels 45B, 45D and 46, in Trenches 382, 457, 461, 462, 487 and 494, groups of such ditches were broadly aligned NNW-SSE and north-south, and were spaced at regular intervals 10-11m apart. A few others in Trenches 351, 376 and 452, were aligned more or less perpendicular on a ENE-WSW or east-west alignment. Such groups of ditches did not extend for long distances, appearing rather to represent relatively limited areas of cultivation, and the exact function and purpose of these ditches remains uncertain.
- 5.2.12 Four sherds of late Iron Age/early Roman pottery recovered from a more substantial east-west aligned ditch 37606 could suggest something more than the network of cultivation and drainage ditches that probably dominated the slopes of the Mar Dyke valley. This ditch, perhaps along with similarly

substantial, albeit undated, ditches in the vicinity, in Trenches 379, 382 and possibly 390, could represent the remains of one or more late Iron Age/early Roman agricultural enclosures. It is notable, however, that despite their relatively substantial size they were not evident either as cropmarks or in the geophysical survey results, despite being on the same geology as a cropmark enclosure just to the north (and described below).

- 5.2.13 In the main, land use on site in the Roman period can be associated with similar evidence recorded during the evaluation of Iron Age and Roman period settlement to the north-west, higher up the valley slopes in Land Parcels 54 and 126 and to the south in Land Parcel 21 (OCA 2020b, OCA 2021b). In those examples there was evidence for possible cultivation provided by a number of drainage features considered to be similar to lazy beds.
- 5.2.14 The evidence recorded on site suggests that the present investigation probably represents an element of the agricultural hinterland of surrounding rural settlements on the higher ground to the south, west and north-west of the Mar Dyke valley (OCA 2020a; OCA 2020b; OCA 2021b).
- 5.2.15 **Medieval.** In Land Parcel 45D two substantial ditches corresponding to the north and east sides of a rectangular cropmark enclosure measuring c 36m NNW-SSE by c 55m ENE-WSW were identified in Trenches 374 and 375. These ditches contained substantial assemblages of medieval pottery dating between the 11th and 15th centuries and a late medieval horseshoe, together with one, possibly intrusive 16th century (early post-medieval) sherd and a fragment of post-medieval tile. A sherd of medieval pottery found in nearby Trench 282 was presumably associated.
- 5.2.16 Elsewhere only four additional sherds of medieval pottery were recovered. Two of these came from a deposit in Trench 341, also in Land Parcel 45D, and two in NNW-SSE aligned ditches in Trenches 311 and 328 in Land Parcel 45E. These presumably represent material spread in manuring.
- 5.2.17 **Post-medieval and modern.** No evidence of occupation or associated settlement activity was identified within the site, although the remains of infilled former field boundary ditches and other ditches that were probably broadly contemporary with these were recorded (Trenches 442, 443, 519, 521, 523, 525 and 526). These are also evident in the cropmark data, in the results of the geophysical survey and on 19th century historic mapping.
- 5.2.18 **Undated.** It is likely that the greater majority of undated features, predominantly the smaller ditches, gullies, but perhaps postholes and small pits may relate to the prehistoric or Roman activity within the site. Some may of course be of more recent origin.
- 5.2.19 **Natural features.** The evaluation recorded a number of potential features which were interpreted as of natural origin and are the result of variations in the natural geology.

5.3 Evaluation objectives and results

- 5.3.1 Aims i-vii. This evaluation established the presence of archaeological remains and investigated their character by analysing artefacts and environmental evidence. The evaluation also ground-truthed the cropmark evidence identified by the 2019 aerial survey (Place Services 2019) and the results of

the geophysical survey (Magnitude Surveys 2020). The evaluation also investigated the apparently blank areas where no cropmarks were evident and geophysical survey results were either inconclusive or presented no evidence.

- 5.3.2 Aim viii. The presence of alluvial deposits, which were recorded in Trenches 362, 394, 397, 400, 403-408, 412, 414-415, 417-418, 425-427, 430, 433-436, 438, 440-441, 443, 445, 449-452, 456, 461 and 531. is summarised in the archaeological narrative, and is described in detail in the geoarchaeological report that accompanies this report (Appendix D). The extent of alluvium revealed by the trenching matched very closely to the low-lying areas indicated in the topographic model produced in WSI P (OA 2021, figs 4b and 4c), and confirmed the presence of a promontory of slightly higher ground projecting east across part of Land Parcel 45B into 48H.
- 5.3.3 To summarise, the alluvial deposits, which comprise an element of the Holocene sequence across much of Land Parcels 45C, 45B and 46, vary over three main zones. On the higher ground in the dry valley moving to the north-west away from the valley bottom and on the lower islands within the valley the sequence is shallow and comprises modern topsoils, subsoils and thin alluvial layers with archaeological activity occurring beneath these. The sequence becomes thicker on the floodplain margins, consisting of leached horizons and alluvial deposits that overlie weathered London Clay and Pleistocene Head deposits. Further into the floodplain the sequence become deeper and more complex, comprising potential channel deposits, leached horizons overlain by intercalated alluvium and stabilisation horizons.
- 5.3.4 Archaeological features were sealed by alluvium in Trenches 362, 450-452 and possibly in Trench 427, and occurred within an alluvial deposit in Trench 445.
- 5.3.5 Aim ix. No discoveries of regional or national importance have been made during evaluation of this site. At the county and local level, however, several significant discoveries have been made, including the identification of a Roman form of cultivation that is common to several sites around the Mar Dyke valley, but has rarely been identified elsewhere, a late Bronze Age or early Iron Age occupation focus that may include a preserved occupation horizon, and a rectangular medieval enclosure.
- 5.3.6 Objective xiii. The archaeological evaluation conducted the investigation within the general research parameters and objectives defined by the revised East of England Research Framework (Medlycott 2011) and adhered to the aims and objectives of the Greater Thames Estuary Historic Environment Research Framework.
- 5.3.7 Objective xiv. Archaeological remains were found sealed beneath quite thin alluvium in Trenches 362, 450-452, possibly in Trench 427, which lay on the margins of alluvial deposits and in an alluvial deposit in Trench 445. The presence of buried archaeological remains of mid to late Prehistoric origin at the base of the alluvium dates the onset of alluviation in the Mar Dyke valley to the mid-Prehistoric period (late Bronze Age/early Iron Age).
- 5.3.8 Objective xv. Possible palaeochannel deposits were identified overlying weathered London Clay deposits at the southern end of Land Parcel 45C, in Trenches 433 and 434, but none were evident in over the northern part of

- Land Parcel 45B. No evidence that may have indicated activity associated with these former palaeochannels was identified.
- 5.3.9 Objective xvi. A group of WSW-ENE parallel small ditches containing Iron Age pottery was found in Land Parcel 43, and this may indicate cultivation associated with settlement outside the area of the scheme, although several areas of potential domestic Iron Age activity were also identified by the evaluation within the lower slopes of the Mar Dyke valley.
- 5.3.10 Several groups of parallel Roman ditches of distinctive morphology and containing mixed redeposited natural were identified, and similar groups of such ditches have also been identified in Land Parcel 21 on the south side of the Mar Dyke valley and in Land Parcel 54 to the north-west, where they were compared to lazy beds (OCA 2020b and OCA 2021b). All appear to represent a specialised form of Roman cultivation associated with settlements at some distance, in Land Parcels 22 and 21 to the south and at Manor Farm outside the scheme to the north-east (OCA 2020a, OCA 2020b and OCA 2021b). Those found in this evaluation probably relate to settlement to the west in the area of South Ockendon Manor, where three Roman barrows formerly existed. These settlements lay on the higher southern and north-western slopes of the Mar Dyke valley respectively, with the agricultural hinterland focused on the lower slopes and promontories away from the active floodplain.
- 5.3.11 The medieval rectangular small enclosure found in Land Parcel 45D lies within the parish of South Ockendon, and was presumably an outlying enclosure related to the manor of South Ockendon on higher ground west of the site.
- 5.3.12 Objectives xvii and xix. The evaluation confirmed the existence of a rectangular enclosure in Land Parcel 45D, and established that it was medieval. No trenches were dug into the other cropmark rectilinear enclosure, which was in the north-east corner of Land Parcel 46, as this area was excluded from evaluation. No finds other than a flint chip were recovered from the north-south ditch that intersected with this enclosure either. The evaluation did also demonstrated that some of the cropmark ditches in Land Parcel 45B did not relate to archaeological features, but that others were genuine, if undated. An L-shaped cropmark in this land parcel was not tested by evaluation, but Iron Age finds found in an adjacent trench may indicate that these cropmarks were of this period. Many of the archaeological features that were found were not visible as cropmarks, but comprised relatively narrow and shallow ditches and gullies, along with small to moderately sized, shallow pits, postholes and a number of tree-throw holes, which on the London Clay and Head Clay geology tend not to produce cropmarks or clearly evident geophysical survey results. In addition, many of the ditches were deliberately filled with redeposited natural clay, and other naturally silted features also contained clayey deposits of very similar composition to the surrounding natural substrate, making them more difficult to discern.
- 5.3.13 Aim xviii. No domestic activity of earlier prehistoric, ie Mesolithic or Neolithic, date was found in the evaluation. The earliest evidence of probable domestic activity was of the middle Bronze Age.
- 5.3.14 Aim xx. No trace of the Roman cemetery, whose exact location is uncertain, but which was believed to lie either in the northern part of Land Parcel 43 or

45E or further east, was found by the evaluation, as these areas were either excluded from evaluation or could not be accessed.

- 5.3.15 Aim xxi. A number of field boundaries were visible from the geophysical survey within the site, and a group of cropmark linear features were also evident in Land Parcel 45B. Some of the latter proved not to correspond to archaeological features, while others did relate to ditches, but did not contain dating evidence. Iron Age finds from a trench adjacent to one of these cropmarks may indicate a later prehistoric date for the genuine examples rather than medieval or later.
- 5.3.16 Most of the features identified by the geophysical survey were also present on historic maps of the 19th century, and several of these were confirmed as corresponding to ditches containing post-medieval finds. Post-medieval field boundaries corresponding with those depicted on historic maps and evident as cropmarks, and other ditches that were probably broadly contemporary with these were recorded were identified in Trenches 442, 443, 519, 521, 523, 525 and 526 in Land Parcels 43 and 45B. None of the historic boundaries appeared to be of medieval origin.

Appendix A Trench Tables

Trench 297							
General description						Orientation	N-S
Trench devoid of archaeology. Ploughsoil onto clay and gravel natural						Length (m)	30
						Width (m)	2
						Avg. depth (m)	0.55
Context No.	Type	Fill Of	Width (m)	Depth (m)	Description	Finds	Date
29700	Layer			0.4	Ploughsoil. Dark grayish brown		
29701	Layer				Natural. Brownish yellow clay with some gravel		
Trench 303							
General description						Orientation	E-W
Trench devoid of archaeology. Consists of Ploughsoil overlying the natural geology of clay and gravel						Length (m)	30
						Width (m)	2
						Avg. depth (m)	0.5
Context No.	Type	Fill Of	Width (m)	Depth (m)	Description	Finds	Date
30300	Layer		2	0.3	Ploughsoil. Dark grayish brown		
30301	Layer				Natural. Brownish yellow clay with some gravel and some patches of blue clay		
Trench 304							
General description						Orientation	E-W
Trench devoid of archaeology. Consists of ploughsoil overlying natural geology of clay.						Length (m)	30
						Width (m)	2
						Avg. depth (m)	0.38
Context No.	Type	Fill Of	Width (m)	Depth (m)	Description	Finds	Date
30400	Layer		2	0.38	Ploughsoil. Dark greyish brown loam.		
30401	Layer		2		Natural. Dark reddish brown compact clay with little to no inclusions.		
Trench 305							
General description						Orientation	E-W
						Length (m)	30

Trench devoid of archaeology. Consists of ploughsoil overlying the natural geology of clay						Width (m)	2
						Avg. depth (m)	0.25
Context No.	Type	Fill Of	Width (m)	Depth (m)	Description	Finds	Date
30500	Layer		2	0.25	Ploughsoil. Dark greyish brown loam.		
30501	Layer		2		Natural. Dark reddish brown compact clay with little to no inclusions.		
Trench 306							
General description						Orientation	E-W
Trench revealed two ditches, ditch terminus and pit. Trench consists of ploughsoil overlying the subsoil and then natural geology of clay.						Length (m)	30
						Width (m)	2
						Avg. depth (m)	0.3
Context No.	Type	Fill Of	Width (m)	Depth (m)	Description	Finds	Date
30600	Layer		2	0.3	Ploughsoil. Dark greyish brown loam		
30601	Layer		2		Natural. Mid reddish brown compact clay with little to no inclusions.		
30602	Cut		0.72	0.17	Ditch		
30603	Fill	30602	0.72	0.17	Secondary Fill. Light yellowish brown, clayey sand.	Fired clay Flint	
30604	Cut		0.61	0.08	Pit		
30605	Fill	30604	0.61	0.08	Secondary Fill. Mid yellowish brown, sandy clay.		
30606	Cut		0.5	0.26	Ditch		
30607	Fill	30606	0.5	0.26	Secondary Fill. Light whiteish yellow clay with reddish yellow mottling.		
30608	Layer				Subsoil. Dark orange brown friable sandy silt.		
30609	Cut		0.84	0.3	Ditch		
30610	Fill	30609	0.66	0.18	Secondary Fill. Firm/friable mottled light grey white and light orange brown silty sand. <5% small		

					gravel and charcoal inclusions. No dateable evidence recovered.		
30611	Fill	30609	0.66	0.1	Secondary Fill. Friable mottled mid grey brown with mid orange brown silty clay. <5% small gravel inclusions including flint. Some small finds recovered.	Pottery Fired clay Flint	LBA/EIA?
Trench 307							
General description						Orientation	E-W
Trench devoid of archaeology. Ploughsoil overlying the natural geology of clay.						Length (m)	30
						Width (m)	2
						Avg. depth (m)	0.3
Context No.	Type	Fill Of	Width (m)	Depth (m)	Description	Finds	Date
30700	Layer		2	0.3	Ploughsoil. Dark greyish brown loam.		
30701	Layer		2		Natural. Dark orangish brown compact clay with little to no inclusions.		
Trench 308							
General description						Orientation	N-S
Trench devoid of archaeology. Consists of plough soil overlying the natural geology of clay.						Length (m)	30
						Width (m)	2
						Avg. depth (m)	0.3
Context No.	Type	Fill Of	Width (m)	Depth (m)	Description	Finds	Date
30800	Layer		2	0.3	Ploughsoil. Dark greyish brown loam.		
30801	Layer		2		Natural. Dark reddish brown compact clay with little to no inclusions.		
Trench 309							
General description						Orientation	E-W
Trench devoid of archaeology. Consists of plough soil overlying the natural geology of clay.						Length (m)	30
						Width (m)	2
						Avg. depth (m)	0.2

Context No.	Type	Fill Of	Width (m)	Depth (m)	Description	Finds	Date
30900	Layer		2	0.2	Ploughsoil. Dark greyish brown loam.		
30901	Layer		2		Natural. Dark reddish brown compact clay with little to no inclusions.		
30902	Void						

Trench 310

General description	Orientation	N-S
Trench devoid of archaeology. Consists of plough soil overlying the natural geology of clay.	Length (m)	30
	Width (m)	2
	Avg. depth (m)	0.3

Context No.	Type	Fill Of	Width (m)	Depth (m)	Description	Finds	Date
31000	Layer		2	0.3	Ploughsoil. Dark greyish brown loam.		
31001	Layer		2		Natural. Mid brownish orange compact clay with little to no inclusions.		

Trench 311

General description	Orientation	E-W
Trench revealed a single ditch and two postholes. Consists of plough soil overlying the natural geology of clay.	Length (m)	30
	Width (m)	2
	Avg. depth (m)	0.3

Context No.	Type	Fill Of	Width (m)	Depth (m)	Description	Finds	Date
31100	Layer		2	0.3	Ploughsoil. Dark greyish brown loam.		
31101	Layer		2		Natural. Dark reddish brown compact clay with little to no inclusions		
31102	Cut		0.85	0.23	Ditch		
31103	Fill	31102	0.85	0.23	Other Fill. Light yellowish brown, sandy clay		
31104	Cut		0.45	0.05	Natural Feature. Natural hollow, not a pit.		
31105	Cut		0.31	0.23	Posthole		
31106	Cut		0.3	0.18	Posthole		
31107	Fill	31106	0.3	0.18	Secondary Fill. Light grey brown	Pottery Flint	LBA/EIA?

					clay with orange mottling		
31108	Fill	31105	0.32	0.23	Secondary Fill. Dark grey brown clay	Pottery Flint	LBA/EIA?
31109	Unexcavated feature		0.32		Posthole. Most Eastern posthole visible. To the NE of (31106)		
31110	Cut		0.34	0.1	Posthole. Regular circle, with steep regular sides and a clear break of slope at base.		
31111	Void						
31112	Cut		0.71	0.25	Ditch		
31113	Fill	31112	0.71	0.25	Secondary Fill	Flint	
31114	Fill	31110	0.35	0.1	Secondary Fill. Friable mid grey brown silty clay. <5% flint inclusions and some small pot finds recovered.	Pottery	RB
31115	Layer				Subsoil. Friable mid yellow brown silty clay.		

Trench 312

General description						Orientation	NNW-SSE
Trench devoid of archaeology. Consists of ploughsoil overlying the natural geology of clay and gravel.						Length (m)	30
						Width (m)	2
						Avg. depth (m)	0.38
Context No.	Type	Fill Of	Width (m)	Depth (m)	Description	Finds	Date
31200	Layer		2	0.38	Ploughsoil. Dark greyish brown silty clay		
31201	Layer		2		Natural. Light yellowish orange clay		

Trench 313

General description						Orientation	N-S
Trench devoid of archaeology. Consists of ploughsoil overlying the natural geology of clay.						Length (m)	30
						Width (m)	2
						Avg. depth (m)	0.3
Context No.	Type	Fill Of	Width (m)	Depth (m)	Description	Finds	Date
31300	Layer		2	0.3	Ploughsoil. Dark greyish brown loam.		

31301	Layer		2		Natural. Dark reddish brown compact clay with little to no inclusions.		
Trench 314							
General description					Orientation	E-W	
Trench devoid of archaeology. Consists of Ploughsoil overlying the natural geology of clay.					Length (m)	30	
					Width (m)	2	
					Avg. depth (m)	0.32	
Context No.	Type	Fill Of	Width (m)	Depth (m)	Description	Finds	Date
31400	Layer		2	0.32	Ploughsoil. Dark greyish brown silty clay		
31401	Layer		2		Natural. Light greyish yellow compact clay with chalk inclusions		
Trench 315							
General description					Orientation	N-S	
Trench devoid of archaeology. Consists of ploughsoil overlying the natural geology of clay.					Length (m)	30	
					Width (m)	2	
					Avg. depth (m)	0.33	
Context No.	Type	Fill Of	Width (m)	Depth (m)	Description	Finds	Date
31500	Layer		2	0.33	Ploughsoil. Dark greyish brown silty clay		
31501	Layer		2		Natural. Light greyish yellow clay		
Trench 316							
General description					Orientation	E-W	
Trench devoid of archaeology. Consists of ploughsoil overlying the natural geology of clay.					Length (m)	30	
					Width (m)	2	
					Avg. depth (m)	0.38	
Context No.	Type	Fill Of	Width (m)	Depth (m)	Description	Finds	Date
31600	Layer		2	0.38	Ploughsoil. Dark greyish brown silty clay		
31601	Layer		2		Natural. Light yellowish orange compact clay		
Trench 317							
General description					Orientation	N-S	

Trench devoid of archaeology. Consists of ploughsoil overlying the natural geology of clay and gravel.						Length (m)	30
						Width (m)	2
						Avg. depth (m)	0.32
Context No.	Type	Fill Of	Width (m)	Depth (m)	Description	Finds	Date
31700	Layer		2	0.32	Ploughsoil. Dark greyish brown silty clay		
31701	Layer		2		Natural. Light greyish yellow clay		

Trench 318

General description						Orientation	E-W
Trench devoid of archaeology. Consists of ploughsoil overlying the natural geology of clay and gravel.						Length (m)	30
						Width (m)	2
						Avg. depth (m)	0.35
Context No.	Type	Fill Of	Width (m)	Depth (m)	Description	Finds	Date
31800	Layer		2	0.35	Ploughsoil. Dark greyish brown silty clay		
31801	Layer		2		Natural. Light yellowish orange clay		

Trench 319

General description						Orientation	E-W
Devoid of archaeology. Consists of ploughsoil overlying the natural geology of clay.						Length (m)	30
						Width (m)	2
						Avg. depth (m)	0.3
Context No.	Type	Fill Of	Width (m)	Depth (m)	Description	Finds	Date
31900	Layer		2	0.3	Ploughsoil. Dark greyish brown loam.		
31901	Layer		2		Natural. Dark reddish brown compact clay with little to no inclusions.		

Trench 320

General description						Orientation	N-S
Trench devoid of archaeology. Consists of ploughsoil overlying the natural geology of clay.						Length (m)	30
						Width (m)	2
						Avg. depth (m)	0.36
Context No.	Type	Fill Of	Width (m)	Depth (m)	Description	Finds	Date
32000	Layer		2	0.35	Ploughsoil. Dark greyish brown moderately		

					compact silty clay		
32001	Layer		2		Natural. Light greyish yellow compact clay		
Trench 321							
General description						Orientation	E-W
Trench devoid of archaeology. Consists of ploughsoil overlying the natural geology of clay.						Length (m)	30
						Width (m)	2
						Avg. depth (m)	0.36
Context No.	Type	Fill Of	Width (m)	Depth (m)	Description	Finds	Date
32100	Layer		2	0.36	Ploughsoil. Dark greyish brown silty clay		
32101	Layer		2		Natural. Light greyish orange clay		
Trench 322							
General description						Orientation	N-S
Trench devoid of archaeology. Consists of ploughsoil overlying the natural geology of clay.						Length (m)	30
						Width (m)	2
						Avg. depth (m)	0.33
Context No.	Type	Fill Of	Width (m)	Depth (m)	Description	Finds	Date
32200	Layer		2	0.33	Ploughsoil. Dark greyish brown moderately compact silty clay		
32201	Layer		2		Natural. Light yellowish orange compact clay		
Trench 323							
General description						Orientation	E-W
Trench devoid of archaeology. Consists of ploughsoil overlying the natural geology of clay.						Length (m)	30
						Width (m)	2
						Avg. depth (m)	0.33
Context No.	Type	Fill Of	Width (m)	Depth (m)	Description	Finds	Date
32300	Layer		2	0.33	Ploughsoil. Dark greyish brown moderately compact silty clay		
32301	Layer		2		Natural. Light greyish yellow compact clay		

Trench 324							
General description						Orientation	E-W
Trench devoid of archaeology. Consists of ploughsoil overlying the natural geology of clay.						Length (m)	30
						Width (m)	2
						Avg. depth (m)	0.46
Context No.	Type	Fill Of	Width (m)	Depth (m)	Description	Finds	Date
32400	Layer		2	0.3	Ploughsoil. Dark greyish brown loam.		
32401	Layer		2		Natural. Dark reddish brown compact clay with little to no inclusions.		
Trench 325							
General description						Orientation	N-S
Trench devoid of archaeology. Consists of ploughsoil overlying the natural geology of clay.						Length (m)	30
						Width (m)	2
						Avg. depth (m)	0.34
Context No.	Type	Fill Of	Width (m)	Depth (m)	Description	Finds	Date
32500	Layer		2	0.34	Ploughsoil. Dark greyish brown moderately compact silty clay		
32501	Layer		2		Natural. Light greyish orange compact clay		
Trench 326							
General description						Orientation	E-W
Trench devoid of archaeology. Consists of ploughsoil overlying the natural geology of clay.						Length (m)	30
						Width (m)	2
						Avg. depth (m)	0.36
Context No.	Type	Fill Of	Width (m)	Depth (m)	Description	Finds	Date
32600	Layer		2	0.36	Ploughsoil. Dark greyish brown moderately compact silty clay		
32601	Layer		2		Natural. Mid brownish orange compact clay		
Trench 327							
General description						Orientation	N-S
Trench devoid of archaeology. Consists of ploughsoil overlying the natural geology of clay						Length (m)	30
						Width (m)	2

						Avg. depth (m)	0.3
Context No.	Type	Fill Of	Width (m)	Depth (m)	Description	Finds	Date
32700	Layer		2	0.3	Ploughsoil. Dark greyish brown loam.		
32701	Layer		2		Natural. Dark reddish brown compact clay with little to no inclusions.		
Trench 328							
General description						Orientation	E-W
Trench revealed two probable periglacial cracks. Consists of ploughsoil overlying the natural geology of clay.						Length (m)	30
						Width (m)	2
						Avg. depth (m)	0.37
Context No.	Type	Fill Of	Width (m)	Depth (m)	Description	Finds	Date
32800	Layer		2	0.37	Ploughsoil. Dark greyish brown moderately compact silty clay		
32801	Layer		2		Natural. Light greyish yellow compact clay		
32802	Cut		0.6	0.3	Likely natural periglacial feature		
32803	Fill	32802	0.6	0.3	Secondary Fill. Light orange grey clay		
32804	Cut		1.08	0.71	Likely natural periglacial feature		
32805	Fill	32804	1.08	0.55	Secondary Fill. light whitish grey clay	Pottery Fired clay Flint	16th-17th C
32806	Fill	32804	0.15	0.32	Secondary Fill. Mid orange grey clay		
32807	Fill	32804	0.33	0.36	Secondary Fill. Dark brown orange clay	pottery	RB
32808	Cut		0.7	0.45	Same as 32804		
32809	Fill	32808	0.7	0.54	Secondary Fill. Light whitish grey clay. Same as 32805		
32810	Fill	32808	0.18	0.43	Secondary Fill. Mid orange grey clay. Same as 32805		
32811	Fill	32808	0.17	0.1	Secondary Fill. Dark orange		

					brown clay. Same as 32807		
--	--	--	--	--	------------------------------	--	--

Trench 329							
General description						Orientation	E-W
Trench devoid of archaeology. Consists of ploughsoil overlying the natural geology of clay.						Length (m)	30
						Width (m)	2
						Avg. depth (m)	0.35
Context No.	Type	Fill Of	Width (m)	Depth (m)	Description	Finds	Date
32900	Layer		2	0.35	Ploughsoil. Dark greyish brown clayey silt		
32901	Layer		2		Natural. Light yellowish brown silty clay. Head deposit		

Trench 330							
General description						Orientation	N-S
Trench revealed two ditches and a gully. Consists of ploughsoil overlying the natural geology of clay.						Length (m)	30
						Width (m)	2
						Avg. depth (m)	0.3
Context No.	Type	Fill Of	Width (m)	Depth (m)	Description	Finds	Date
33000	Layer		2	0.3	Topsoil. Dark greyish brown loam.		
33001	Layer		2		Natural. Dark orangish brown compact clay with little to no inclusions.		
33002	Cut		1.5	0.35	Ditch		
33003	Fill	33002	1.5	0.35	Secondary Fill. Light grey clay with reddish yellow mottling		
33004	Cut		0.94	0.23	Ditch		
33005	Fill	33004	0.94	0.23	Secondary Fill. Mid yellowish grey, sandy clay		
33006	Cut		0.38	0.1	Gully		
33007	Fill	33006	0.38	0.1	Secondary Fill. Light yellowish grey, sandy clay		

Trench 331							
General description						Orientation	N-S
Trench devoid of archaeology. Consists of ploughsoil overlying the natural geology of clay.						Length (m)	30
						Width (m)	2

							Avg. depth (m)	0.36
Context No.	Type	Fill Of	Width (m)	Depth (m)	Description	Finds	Date	
33100	Layer		2	0.36	Ploughsoil. Dark greyish brown moderately compact silty clay			
33101	Layer		2		Natural. Light greyish orange compact clay with occasional chalk inclusion			

Trench 332

General description	Orientation	NW-SE
Trench devoid of archaeology. Consists of ploughsoil overlying the natural geology of clay.	Length (m)	30
	Width (m)	2
	Avg. depth (m)	0.35

Context No.	Type	Fill Of	Width (m)	Depth (m)	Description	Finds	Date
33200	Layer		2	0.35	Ploughsoil. Dark greyish brown silty clay.		
33201	Layer				Natural. Mid orangish brown compact clay with occasional sub-angular stones.		

Trench 333

General description	Orientation	ENE-WSW
Trench devoid of archaeology. Consists of ploughsoil overlying the natural geology of clay.	Length (m)	30
	Width (m)	2
	Avg. depth (m)	0.35

Context No.	Type	Fill Of	Width (m)	Depth (m)	Description	Finds	Date
33300	Layer		2	0.38	Ploughsoil. Dark grey brown moderately compact silty clay		
33301	Layer		2		Natural. Mid orangish brown compact clay natural with occasional sub-angular stones.		

Trench 334

General description	Orientation	NW-SE
Trench devoid of archaeology. Consists of ploughsoil overlying the natural geology of clay.	Length (m)	30
	Width (m)	2
	Avg. depth (m)	0.36

Context No.	Type	Fill Of	Width (m)	Depth (m)	Description	Finds	Date
33400	Layer		2	0.36	Ploughsoil. Dark greyish brown moderately compact silty clay		
33401	Layer		2		Natural. Mid greyish orange compact clay with gravelly patches		

Trench 335

General description					Orientation	E-W
Trench devoid of archaeology. Consists of ploughsoil overlying the natural geology of clay.					Length (m)	30
					Width (m)	2
					Avg. depth (m)	0.3

Context No.	Type	Fill Of	Width (m)	Depth (m)	Description	Finds	Date
33500	Layer		2	0.3	Topsoil. Dark greyish brown clayey silt		
33501	Layer		2		Natural. Light yellowish brown silty clay. Head deposit		
33502	Cut		0.57	0.06	Natural Feature. Tree throw		

Trench 336

General description					Orientation	EW
Trench revealed one ditch. Consists of ploughsoil overlying the natural geology of clay.					Length (m)	30
					Width (m)	2
					Avg. depth (m)	0.45

Context No.	Type	Fill Of	Width (m)	Depth (m)	Description	Finds	Date
33600	Layer			0.45	Ploughsoil. Dark grayish brown silty clay		
33601	Layer				Natural. Mid grayish brown clay		
33602	Layer			0.12	Subsoil. Mid brown clayey silt. Compacted texture, the thick fraction (5%) contains gravels (1mm-1cm), sub-rounded limestones (1cm-5cm) and some flint nodules (1cm-5cm).		
33603	Cut		0.76	0.32	Ditch. It's a ditch with linear plan running in NW-SE direction.		

33604	Fill		0.69	0.18	Deliberate Backfill. It's the earliest fill of the ditch. Friable texture, clayey silt. Mid orangey grey. The thick fraction (10%) contains some angular gravels (1mm-1cm), some medium size limestones (1cm-5cm) and a few pebbles (1cm-5cm). It's the foundational fill (primary fill) of the ditch 33603. It could belong to an Ancient Age fencing or enclosing structure.		
33605	Fill	33603	0.78	0.15	Deliberate Backfill. Latest fill of 33603, overlying (33604). Friable texture. Mid brown silty clay. The thick fraction of the fill (15%) contains some angular gravels (1mm-1cm), some limestones (1cm-5cm) and flint nodules (1cm-5cm).		

Trench 337

General description						Orientation	NS
Trench devoid of archaeology. Consists of ploughsoil overlying the natural geology of clay and gravel.						Length (m)	30
						Width (m)	2
						Avg. depth (m)	0.9
Context No.	Type	Fill Of	Width (m)	Depth (m)	Description	Finds	Date
33700	Layer		2	0.4	Ploughsoil. Dark grayish brown silty clay		
33701	Layer			0.5	Subsoil. Mid Yellowish brown silty clay		
33702	Layer				Natural. Dark orangeish brown clay with gravel patches and some blue clay		
33703	Cut				Natural Feature. Caused by rooting action		

33704	Cut				Natural Feature. Caused by rooting action		
Trench 338							
General description						Orientation	EW
Trench devoid of archaeology. Consists of ploughsoil and subsoil overlying the natural geology of clay and gravel.						Length (m)	30
						Width (m)	2
						Avg. depth (m)	0.6
Context No.	Type	Fill Of	Width (m)	Depth (m)	Description	Finds	Date
33800	Layer			0.3	Ploughsoil. Dark greyish brown clayey silt		
33801	Layer			0.1	Subsoil. Mid olive brown silty clay		
33802	Layer				Natural. Light yellowish brown silty clay with some blue clay patches. Head deposit		
Trench 339							
General description						Orientation	N-S
Trench devoid of archaeology. Consists of ploughsoil overlying the natural clay.						Length (m)	30
						Width (m)	1.8
						Avg. depth (m)	0.3
Context No.	Type	Fill Of	Width (m)	Depth (m)	Description	Finds	Date
33900	Layer			0.3	Ploughsoil. Mid greyish brown. Silty clay		
33901	Layer				Natural. Mid reddish brown. Clayey clay.		
33902	Void						
Trench 340							
General description						Orientation	E-W
Trench consists of ploughsoil overlying the natural clay geology. No archaeology present.						Length (m)	30
						Width (m)	1.8
						Avg. depth (m)	0.3
Context No.	Type	Fill Of	Width (m)	Depth (m)	Description	Finds	Date
34000	Layer			0.3	Ploughsoil. Mid greyish brown. Silty clay.		
34001	Layer				Natural. Mid yellowish brown. Clayey clay.		

Trench 341							
General description						Orientation	E-W
Two small pits and one ditch at east end of trench. Potential quarry pit in west part of trench. Consists of ploughsoil overlying clayey head in east of trench.						Length (m)	30
						Width (m)	2
						Avg. depth (m)	0.38
Context No.	Type	Fill Of	Width (m)	Depth (m)	Description	Finds	Date
34100	Layer		2	0.28	Topsoil. Dark greyish brown sandy silt		
34101	Layer		2	0.07	Subsoil. Dark mottled reddish brown with greyish brown compact clay with frequent CBM and charcoal inclusions.		
34102	Layer		2		Natural. Dark orangish brown compact clay with little to no inclusions.		
34103	Cut		1.35	0.32	Natural Feature. NE-SW orientated. Possible drainage ditch. Break slope top imperceptible, moderately concave sides, break of slope base gradual, base is irregular.		
34104	Fill	34103	1.35	0.32	Secondary Fill. Consists of redeposited natural. Small fragment of pot present in fill. Firm, mid reddish grey, silty clay, rare chalk inclusions.		L11th – E13th C
34105	Cut			0.9	Other Cut. Possible quarry pit or pond feature		
34106	Fill	34105		0.52	Secondary Fill. Dark brownish grey clayey silt with light orangey brown mottling. Charcoal and CBM inclusions		
34107	Cut		2.16	0.28	Ditch		
34108	Fill	34107	2.16	0.28	Primary Fill. Compact, medium bluish yellow, silty clay, occasional animal teeth and one pot fragment		
34109	Cut		0.94	0.16	Pit		

34110	Fill	34109	0.94	0.16	Primary Fill. Compact, medium bluish yellow, silt clay, occasional small rounded stones		
34111	Cut		0.64	0.26	Pit		
34112	Fill	34111	0.64	0.26	Primary Fill. Compact, medium bluish yellow, silty clay, occasional small rounded stones		
34113	Fill	34105		0.05	Secondary Fill. Dark yellowish brown fine sandy silt with frequent iron mottling		
34114	Fill	34105		0.16	Secondary Fill. Dark yellowish brown clayey silt		
34115	Layer			0.54	Natural. Dark yellowish brown silty clay. Weathered London Clay		
34116	Layer			0.08	Natural. Dark brownish grey silty clay. Weathered London Clay horizon		
34117	Layer				Natural. Dark yellowish brown silty clay. London Clay bedrock		

Trench 342

General description						Orientation	N-S
Devoid of archaeology. Consists of topsoil overlying natural geology.						Length (m)	30
						Width (m)	2
						Avg. depth (m)	0.3
Context No.	Type	Fill Of	Width (m)	Depth (m)	Description	Finds	Date
34200	Layer			0.3	Topsoil. Dark greyish brown silty clay.		
34201	Layer				Natural. Dark reddish brown clay.		

Trench 343

General description						Orientation	E-W
Trench revealed three ditches. Consists of topsoil overlying a clay natural.						Length (m)	30
						Width (m)	2
						Avg. depth (m)	0.3

Context No.	Type	Fill Of	Width (m)	Depth (m)	Description	Finds	Date
34300	Layer			0.3	Topsoil. Dark greyish brown clayey silt.		
34301	Layer				Natural. Dark orangish brown compact clay with little to no inclusions.		
34302	Cut		0.95	0.32	Ditch		
34303	Fill	34302	0.95	0.32	Secondary Fill. Mottled dark bluish and reddish brown silty clay.		
34304	Cut		0.6	0.18	Ditch. N-S		
34305	Fill	34304	0.6	0.18	Secondary Fill. Dark grey brown compact clayey silt with orange mottling. Sample 95.	Fe Nail	
34306	Cut		0.9	0.46	Ditch. N-S		
34307	Fill	34306	0.9	0.46	Primary Fill. Mod compact dark blueish grey clayey silt with red mottling.		
34308	Void						

Trench 344

General description	Orientation	N-S
Devoid of archaeology. Topsoil coming down directly on to natural.	Length (m)	30
	Width (m)	2
	Avg. depth (m)	0.3

Context No.	Type	Fill Of	Width (m)	Depth (m)	Description	Finds	Date
34400	Layer			0.3	Topsoil. Dark greyish brown silty clay.		
34401	Layer				Natural. Dark reddish brown clay.		

Trench 345

General description	Orientation	E-W
Devoid of archaeology. Topsoil onto subsoil onto natural.	Length (m)	30
	Width (m)	2
	Avg. depth (m)	0.3

Context No.	Type	Fill Of	Width (m)	Depth (m)	Description	Finds	Date
34500	Layer			0.3	Topsoil. Dark greyish brown silty clay.		

34501	Layer			0.26	Subsoil. Mid reddish brown clay.		
34502	Void						
34503	Layer				Natural. Dark reddish brown clay.		
34504	Void						
Trench 346							
General description						Orientation	N-S
Trench revealed one ditch. Topsoil onto two layers of brickearth type deposits.						Length (m)	30
						Width (m)	2
						Avg. depth (m)	0.3
Context No.	Type	Fill Of	Width (m)	Depth (m)	Description	Finds	Date
34600	Layer			0.26	Topsoil. Dark greyish brown slightly silty clay.		
34601	Layer			0.13	Other Layer. Mid grey mottled with mid yellowish brown with significant oxidisation. clay		
34602	Layer			0.13	Other Layer. Mid yellowish brown mottled with light grey. Slightly silty clay		
34603	Cut		0.66	0.31	Ditch		
34604	Fill	34603	0.66	0.31	Primary Fill. Dark grey mottled yellow silty clay.		
Trench 347							
General description						Orientation	E-W
Devoid of archaeology. Trench consists of ploughsoil overlying the natural clay.						Length (m)	30
						Width (m)	1.8
						Avg. depth (m)	0.4
Context No.	Type	Fill Of	Width (m)	Depth (m)	Description	Finds	Date
34700	Layer			0.4	Ploughsoil. Dark greyish black. Silty clay		
34701	Layer				Natural. Mid reddish brown with yellow inclusions. Clayey clay		
Trench 348							
General description						Orientation	N-S
Trench devoid of archaeology. Consisted of ploughsoil overlying the natural clay geology.						Length (m)	30
						Width (m)	1.8

							Avg. depth (m)	0.3
Context No.	Type	Fill Of	Width (m)	Depth (m)	Description	Finds	Date	
34800	Layer			0.3	Ploughsoil. Mid greyish brown. Silty clay.			
34801	Layer				Natural. Light yellowish brown. Clayey clay.			

Trench 349

General description						Orientation	N-S
Trench revealed three ditches. Consists of ploughsoil overlying the natural clay.						Length (m)	30
						Width (m)	1.8
						Avg. depth (m)	0.3

Context No.	Type	Fill Of	Width (m)	Depth (m)	Description	Finds	Date
34900	Layer			0.3	Ploughsoil. Mid greyish brown. Silty clay		
34901	Layer				Natural. Mid reddish brown. Clayey clay		
34902	Cut		1	0.7	Ditch		
34903	Fill	34902	1	0.7	Primary Fill. Light reddish brown, clay.		
34904	Cut		0.9	0.57	Ditch		
34905	Fill	34904	0.9	0.57	Primary Fill. Light blue grey with yellow mottling, clay.		
34906	Cut		0.32	0.16	Gully		
34907	Fill			0.16	Primary Fill. Mottled mid grey and light brown clay.		
34908	Void						

Trench 350

General description						Orientation	E-W
Devoid of archaeology. Topsoil coming down directly on to natural.						Length (m)	30
						Width (m)	2
						Avg. depth (m)	0.3

Context No.	Type	Fill Of	Width (m)	Depth (m)	Description	Finds	Date
35000	Layer			0.3	Topsoil. Dark greyish brown silty clay.		
35001	Layer				Natural. Mid reddish brown clay.		

Trench 351							
General description						Orientation	N-S
Trench revealed one ditch. Topsoil coming down directly on to natural.						Length (m)	30
						Width (m)	2
						Avg. depth (m)	0.3
Context No.	Type	Fill Of	Width (m)	Depth (m)	Description	Finds	Date
35100	Layer			0.3	Topsoil. Dark greyish brown silty clay.		
35101	Layer				Natural. Mid reddish brown clay.		
35102	Layer			0.1	Subsoil. Yellowish brown silty clay.		
35103	Cut		1.1	0.47	Ditch		
35104	Fill	35103	0.73	0.35	Secondary Fill. Light yellowish grey silty clay.	Pottery Flint	RB
35105	Fill	35103	0.97	0.3	Primary Fill. Light greyish yellow, silty clay.	Pottery	LBA/EIA ?
Trench 352							
General description						Orientation	E-W
Trench revealed one gully. Topsoil coming down directly on to natural.						Length (m)	30
						Width (m)	2
						Avg. depth (m)	0.3
Context No.	Type	Fill Of	Width (m)	Depth (m)	Description	Finds	Date
35200	Layer			0.3	Topsoil. Dark greyish brown silty clay.		
35201	Layer				Natural. Mid reddish brown clay.		
35202	Cut		0.45	0.08	Gully		
35203	Fill	35202	0.45	0.08	Primary Fill. Light grey brown. Silty clay.		
Trench 353							
General description						Orientation	N-S
Trench devoid of archaeology. Consists of topsoil overlying subsoil and head deposit, under which is London Clay.						Length (m)	30
						Width (m)	2
						Avg. depth (m)	0.86
Context No.	Type	Fill Of	Width (m)	Depth (m)	Description	Finds	Date
35300	Layer			0.33	Topsoil. Dark grey clayey silt.		
35301	Layer			0.13	Subsoil. Mid brownish reddish clayey silt.		
35302	Layer			0.36	Other Layer. Mid greyish brown silty clay.		
35303	Layer			0.04	Natural. Dark mottled greyish brown and red silty clay.		

Trench 354							
General description						Orientation	E-W
Trench revealed one ditch. Topsoil coming onto two subsoils onto the natural						Length (m)	30
						Width (m)	2
						Avg. depth (m)	
Context No.	Type	Fill Of	Width (m)	Depth (m)	Description	Finds	Date
35400	Layer			0.3	Topsoil. Dark greyish brown silty clay.		
35401	Layer			0.24	Subsoil. Mid yellowish brown silty clay.		
35402	Layer				Natural. Dark reddish brown clay.		
35403	Cut	35403			Natural Feature		
35404	Cut		3.7	>0.66	Ditch		
35405	Fill	35404	2.6	0.32	Secondary Fill. Mid blueish orange-ish grey, clayey clay.		
35406	Fill	35404	3.7	0.52	Secondary Fill. Mid greyish red, silty clay.	CBM	
35407	Fill	35404	1.8	0.45	Secondary Fill. Dark blue grey, silty clay.		
Trench 355							
General description						Orientation	N-S
Trench devoid of archaeology. Consists of ploughsoil overlying clay natural.						Length (m)	30
						Width (m)	2
						Avg. depth (m)	0.45
Context No.	Type	Fill Of	Width (m)	Depth (m)	Description	Finds	Date
35500	Layer			0.45	Ploughsoil. Dark blackish brown silty clay.		
35501	Layer				Natural. Mid reddish brown clay.		
Trench 356							
General description						Orientation	E-W
Trench devoid of archaeology. Consists of ploughsoil onto clay natural.						Length (m)	30
						Width (m)	2
						Avg. depth (m)	0.34
Context No.	Type	Fill Of	Width (m)	Depth (m)	Description	Finds	Date
35600	Layer			0.34	Topsoil. Dark greyish brown moderately compact silty clay		
35601	Layer				Natural. Light yellowish orange compact silty clay		

Trench 357							
General description						Orientation	E-W
Trench devoid of archaeology. Consisted of ploughsoil overlying the natural clay geology.						Length (m)	30
						Width (m)	1.8
						Avg. depth (m)	0.35
Context No.	Type	Fill Of	Width (m)	Depth (m)	Description	Finds	Date
35700	Layer			0.35	Ploughsoil. Dark greyish brown. Silty clay.		
35701	Layer				Natural. Mid orange brown. Clayey clay.		
Trench 358							
General description						Orientation	N-S
Devoid of archaeology. Topsoil coming down directly on to natural. Land drain on northern side.						Length (m)	30
						Width (m)	2
						Avg. depth (m)	0.3
Context No.	Type	Fill Of	Width (m)	Depth (m)	Description	Finds	Date
35800	Layer		2	0.3	Topsoil. Dark greyish brown silty clay.		
35801	Layer		2		Natural. Dark reddish brown compact clay with little to no inclusions.		
Trench 359							
General description						Orientation	E-W
Trench revealed two ditches. Topsoil coming down directly on to natural.						Length (m)	30
						Width (m)	2
						Avg. depth (m)	0.3
Context No.	Type	Fill Of	Width (m)	Depth (m)	Description	Finds	Date
35900	Layer		2	0.3	Topsoil. Dark greyish brown silty clay.		
35901	Layer		2		Natural. Dark reddish brown compact clay with little to no inclusions.		
35902	Cut		1.1	0.14	Ditch		
35903	Fill	35902	1.1	0.14	Secondary Fill. Mid reddish brown silty clay.		
35904	Cut		0.71	0.52	Ditch		
35905	Fill	35904	0.35	0.16	Deliberate Backfill. Mid reddish grey silty clay.		
35906	Fill	35904	0.74	0.36	Secondary Fill. Mid greyish red silty clay.		
35907	Cut		1.2	1.7	Natural Feature		
35908	Void						

Trench 360							
General description						Orientation	N-S
Trench devoid of archaeology. Consists of ploughsoil overlying the natural clay.						Length (m)	30
						Width (m)	1.8
						Avg. depth (m)	0.3
Context No.	Type	Fill Of	Width (m)	Depth (m)	Description	Finds	Date
36000	Layer			0.3	Ploughsoil. Mid greyish brown. Silty clay.		
36001	Layer				Natural. Mid orange brown. Clayey clay.		
Trench 361							
General description						Orientation	E-W
Trench devoid of archaeology. Consists of ploughsoil and subsoil on head deposit, overlying London natural clay						Length (m)	30
						Width (m)	6
						Avg. depth (m)	2
Context No.	Type	Fill Of	Width (m)	Depth (m)	Description	Finds	Date
36100	Layer			0.35	Ploughsoil. Dark grey brown clay silt.		
36101	Layer			0.2	Subsoil. Mid brown orange clay silt.		
36102	Layer			0.36	Colluvial Layer. Mid grey brown silt clay.		
36103	Layer				Natural. Mid brown grey silt clay with mid grey mottling.		
Trench 362							
General description						Orientation	N-S
1 ditch. 1 gully. 1 possible pit/rooting Consists of ploughsoil overlying possible alluvial layer. Head deposit below this on top of natural London clay.						Length (m)	30
						Width (m)	2
						Avg. depth (m)	1
Context No.	Type	Fill Of	Width (m)	Depth (m)	Description	Finds	Date
36200	Layer			0.36	Topsoil. Dark greyish brown moderately compact silty clay		
36201	Layer			0.24	Alluvial Layer. Light yellowish brown mottled with light grey sandy silt		
36202	Layer			0.34	Other Layer. Mid brown mottled with mid grey. Silty clay with few small angular pebbles.		
36203	Layer			0.06	Natural. Mid reddish brown mottled with mid grey		

36204	Cut		0.22	0.17	Gully		
36205	Fill	36204		0.17	Primary Fill. Compact silty clay. Mottled mid grey and light brown.		
36206	Cut		1.64	0.26	Ditch		
36207	Fill	36206			Primary Fill. Mottled mid grey and light orangey brown compact clay.		
Trench 363							
General description						Orientation	EW
Trench devoid of archaeology. Consists of ploughsoil overlying clayey silt head natural						Length (m)	30
						Width (m)	2
						Avg. depth (m)	0.4
Context No.	Type	Fill Of	Width (m)	Depth (m)	Description	Finds	Date
36300	Layer			0.3	Ploughsoil. Dark greyish brown clayey silt		
36301	Layer				Natural. Mid reddish brown clayey silt. Head deposit		
Trench 364							
General description						Orientation	N-S
Trench devoid of archaeology. Consists of ploughsoil overlaying a clay natural						Length (m)	30
						Width (m)	2
						Avg. depth (m)	0.32
Context No.	Type	Fill Of	Width (m)	Depth (m)	Description	Finds	Date
36400	Layer			0.32	Topsoil. Dark greyish brown moderately compact silty clay		
36401	Layer				Natural. Light yellowish orange silty clay		
Trench 365							
General description						Orientation	SW-NE
Consists of ploughsoil and subsoil overlying natural clay. Archaeology includes one possible linear feature across middle.						Length (m)	30
						Width (m)	1.8
						Avg. depth (m)	0.6
Context No.	Type	Fill Of	Width (m)	Depth (m)	Description	Finds	Date
36500	Layer			0.2	Ploughsoil. Mid blackish brown silty clay		
36501	Layer			0.4	Subsoil. Light yellowish brown sandy clay with blue patches.		

36502	Layer				Natural. Mid yellowish brown clay with lots of dark patches of rooting		
36503	Cut		1.54	0.52	Ditch		
36504	Fill	36503	0.24	0.15	Secondary Fill		
36505	Fill	36503	1.54	0.38	Secondary Fill		

Trench 366

General description						Orientation	E-W
Trench devoid of archaeology. Consists of ploughsoil overlying the natural clayey silt head						Length (m)	30
						Width (m)	2
						Avg. depth (m)	0.33
Context No.	Type	Fill Of	Width (m)	Depth (m)	Description	Finds	Date
36600	Layer			0.33	Topsoil. Dark greyish brown moderately compact clayey silt		
36601	Layer				Natural. Light greyish yellow compact clayey silt. Head deposit		

Trench 367

General description						Orientation	N-S
Trench devoid of archaeology. Consists of ploughsoil and subsoil overlying the natural clay.						Length (m)	30
						Width (m)	2
						Avg. depth (m)	0.34
Context No.	Type	Fill Of	Width (m)	Depth (m)	Description	Finds	Date
36700	Layer			0.34	Topsoil. Dark greyish brown moderately compact silty clay		
36701	Layer				Natural. Light greyish yellow compact clay		

Trench 368

General description						Orientation	E-W
Trench devoid of archaeology. Consists of ploughsoil overlying the natural clayey silt head						Length (m)	30
						Width (m)	2
						Avg. depth (m)	0.32
Context No.	Type	Fill Of	Width (m)	Depth (m)	Description	Finds	Date
36800	Layer			0.32	Topsoil. Dark greyish brown moderately compact clayey silt		
36801	Layer				Natural. Light orangey yellow compact clayey silt. Head deposit		

Trench 369

General description						Orientation	N-S
---------------------	--	--	--	--	--	-------------	-----

Trench consists of ploughsoil overlying the natural clay. One ditch identified, truncated by machine.						Length (m)	20
						Width (m)	1.8
						Avg. depth (m)	0.3
Context No.	Type	Fill Of	Width (m)	Depth (m)	Description	Finds	Date
36900	Layer			0.3	Ploughsoil. Mid greyish brown. Silty clay		
36901	Layer			0.28	Subsoil. Mid yellowish brown. Clayey clay		
36902	Layer				Natural. Mid reddish brown. Clayey clay.		
36903	Cut		1.45	0.38	Ditch		
36904	Fill	36903		0.38	Deliberate Backfill. Mid brownish grey silty clay, moderately compact with occasional charcoal flecks.		
36905	Cut		0.44	0.17	Ditch		
36906	Fill	36905	0.44	0.17	Primary Fill. Mid grey brown. Silty clay.		

Trench 370

General description						Orientation	NW-SE
Trench consists of ploughsoil overlying possible alluvium/brickearth deposit. Followed by secondary brickearth deposit on top of natural London clay. One ditch identified, slightly truncated by machine during excavation.						Length (m)	30
						Width (m)	1.8
						Avg. depth (m)	0.35
Context No.	Type	Fill Of	Width (m)	Depth (m)	Description	Finds	Date
37000	Layer			0.22	Ploughsoil. Dark greyish brown. Silty clay		
37001	Layer			0.24	Other Layer. Light yellowish brown mottled with light grey and speckles of mid reddish reddish oxidisation. Clayey silt.		
37002	Layer				Other Layer. Dark yellowish brown slighty mottled by mid grey. Clay		
37003	Layer			0.18	Natural. Mid reddish brown mottled by mid grey. Silty clay		
37004	Cut		1.12	0.46	Ditch. Moderate concave sloping sides with no obvious break of slope at base. Bulk section in trench wall.		
37005	Fill	37004	1.12	0.46	Secondary Fill. Friable, mid reddish grey silty clay. No inclusions or finds.		

37006	Cut		1.56	0.72	Ditch		
37007	Fill	37006	1.56	0.72	Primary Fill. Mid orangey grey. Compact. Silty clay.		
Trench 371							
General description						Orientation	NS
Trench devoid of archaeology. Consists of ploughsoil overlying clay natural						Length (m)	30
						Width (m)	2
						Avg. depth (m)	0.5
Context No.	Type	Fill Of	Width (m)	Depth (m)	Description	Finds	Date
37100	Layer			0.5	Ploughsoil. Dark blackish brown silty clay		
37101	Layer				Natural. mid reddish brown clay		
Trench 372							
General description						Orientation	E-W
3 pits (determined to be natural features) 3 ditches (two determined to be archaeological features and one natural), one 1 small pit Consists of ploughsoil onto clay natural						Length (m)	30
						Width (m)	2
						Avg. depth (m)	0.35
Context No.	Type	Fill Of	Width (m)	Depth (m)	Description	Finds	Date
37200	Layer			0.35	Topsoil. Dark greyish brown moderately compact silty clay		
37201	Layer				Natural. Light greyish orange compact clay with gravel inclusions		
37202	Cut		1.12	0.26	Ditch		
37203	Fill	37202	1.12	0.26	Primary Fill. Mid grey brown. Silty clay.		
37204	Cut		0.72	0.16	Ditch		
37205	Fill	37204	0.72	0.16	Secondary Fill. Mid brownish grey, silty clay, compact	CBM	Post-med/mod
37206	Cut		0.78	0.15	Natural Feature. Possible rooting/contamination in a linear arrangement. Originally interpreted as a ditch but following testing, it is not a feature. Photo numbers 5624 and 5625		
Trench 373							
General description						Orientation	NW-SE
						Length (m)	30

Trench consists of ploughsoil overlying the natural clay. Devoid of archaeology						Width (m)	1.8
						Avg. depth (m)	0.3
Context No.	Type	Fill Of	Width (m)	Depth (m)	Description	Finds	Date
37300	Layer			0.3	Ploughsoil. Mid greyish brown. Silty clay		
37301	Layer				Natural. Mid reddish brown. Silty clay		
Trench 374							
General description						Orientation	N-S
Trench consisted of ploughsoil overlying the natural clay geology. Two ditches, one possible gully/field drain and one discreet identified.						Length (m)	30
						Width (m)	1.8
						Avg. depth (m)	0.35
Context No.	Type	Fill Of	Width (m)	Depth (m)	Description	Finds	Date
37400	Layer			0.35	Ploughsoil. Dark greyish brown. Silty clay.		
37401	Layer				Natural. Dark yellowish brown. Clayey clay.		
37402	Cut		4.8	0.81	Ditch		
37403	Fill	37402	4.8	0.81	Primary Fill. Silty clay. Mid greyish brown.	Pot Fe Nail	16th C?

Trench 375							
General description						Orientation	E-W
Trench consists of ploughsoil overlying the natural clay. Two ditches, one re-cut ditch.						Length (m)	30
						Width (m)	1.8
						Avg. depth (m)	0.43
Context No.	Type	Fill Of	Width (m)	Depth (m)	Description	Finds	Date
37500	Layer			0.35	Ploughsoil. Mid greyish brown. Silty clay		
37501	Layer				Natural. Mid reddish brown. Clayey clay		
37502	Cut		0.7	0.39	Ditch		
37503	Fill	37502	0.7	0.39	Primary Fill. Mid grey brown, compact silty clay with moderate charcoal inclusions.		
37504	Cut		1.02	0.3	Tree Throw		
37505	Fill	37504	1.02	0.3	Primary Fill. Mid grey brown. Silty clay.		
37506	Cut		4.5	0.62	Ditch		
37507	Fill	37509	1.42	0.62	Secondary Fill. Dark Grey brown, friable silty clay, no inclusions	Pottery Pottery CBM Flint	LIA/ERB 15th C? Post-med/mod

						Fe Horse shoe	Late medieval
37508	Fill	37506	4.5	0.3	Secondary Fill. Mid grey brown friable silty clay with 5% gravel inclusions	Pot Flint	16th C?
37509	Cut		1.42	0.62	Ditch		
37510	Void						
37511	Cut		0.8	0.32	Ditch		
37512	Fill	37511	0.8	0.32	Primary Fill. Mid grey brown friable silty clay with rare subangular stone inclusions.		
37513	Cut		1.06	0.69	Ditch		
37514	Fill	37513			Primary Fill. Mid brownish grey compact clay with mid brown mottled patches.	pottery	LIA/ERB

Trench 376

General description						Orientation	N-S
Trench contains three ditches. Trench consists of ploughsoil overlying the natural clay.						Length (m)	30
						Width (m)	1.8
						Avg. depth (m)	0.35
Context No.	Type	Fill Of	Width (m)	Depth (m)	Description	Finds	Date
37600	Layer			0.35	Ploughsoil. Mid greyish brown. Silty clay		
37601	Layer				Natural. Mid reddish brown. Clayey clay		
37602	Cut		1.2	0.2	Ditch		
37603	Fill	37602	1.1	0.22	Primary Fill. Dark grey brown, clay, occasional small rounded stones.		
37604	Cut		0.58	0.14	Ditch		
37605	Fill	37604	0.58	0.14	Primary Fill. Light orange brown with grey mottling, silty clay, no inclusions.		
37606	Cut		2.1	0.51	Ditch		
37607	Fill	37606	2.1	0.42	Primary Fill. Mid blue grey with orange mottling, silty clay.		
37608	Fill	37606	0.7	0.28	Deliberate Backfill. Dark blue grey, clay.	Pottery CBM	LIA/ERB Post- med/mod

Trench 377

General description						Orientation	E-W
Trench devoid of archaeology. Consists of ploughsoil overlying the natural clay. Excavated to a total depth of 1m.						Length (m)	30
						Width (m)	1.8
						Avg. depth (m)	0.3

Context No.	Type	Fill Of	Width (m)	Depth (m)	Description	Finds	Date
37700	Layer			0.3	Ploughsoil. Mid greyish brown. Silty clay.		
37701	Layer			0.22	Natural. Mid yellowish brown. Clayey clay.		
37702	Layer				Natural. Mid reddish brown with chalk inclusions. Clayey clay.		

Trench 378

General description	Orientation	N-S
Two ditches one re-cut and one pit. Topsoil overlying two brickearth type deposits. London clay natural below these deposits.	Length (m)	30
	Width (m)	2
	Avg. depth (m)	1

Context No.	Type	Fill Of	Width (m)	Depth (m)	Description	Finds	Date
37800	Layer			0.3	Topsoil. Dark greyish brown moderately compact silty clay		
37801	Layer			0.13	Other Layer. Mid yellowish brown mottled with light greyish brown. Slightly silty clay.		
37802	Layer			0.39	Other Layer. Mid reddish brown mottled with mid grey. Very slightly silty clay.		
37803	Layer			0.1	Natural. Mid orangey brown mottled with mid grey. Very slightly sandy silty clay.		
37804	Cut		1.91	0.7	Ditch		
37805	Fill	37804	1	0.52	Secondary Fill. Very compact, mid orange brown with grey patches		
37806	Cut		1.37	0.61	Ditch		
37807	Fill	37806	1	0.61	Secondary Fill. Mod compact, mid greyish brown, silty clay		
37808	Cut		0.68	1.06	Pit		
37809	Fill	37808	0.36	0.16	Primary Fill. Soft, reddish brown, silty clay, occasional small rounded stones		
37810	Fill	37808	0.42	0.16	Secondary Fill. Compact, greyish white, silty clay (powdery), occasional charcoal flecks		
37811	Fill	37808	1.19	0.25	Tertiary Fill. Hard, mottled yellowish brown, silty clay,		

					occasional small rounded stones		
37812	Fill	37808	0.33	0.14	Other Fill. Compact, orange-brown, silty clay, occasional stones and charcoal flecks		
Trench 379							
General description						Orientation	N-S
Trench revealed one ditch. Consists of ploughsoil onto clay natural.						Length (m)	30
						Width (m)	2
						Avg. depth (m)	0.35
Context No.	Type	Fill Of	Width (m)	Depth (m)	Description	Finds	Date
37900	Layer			0.35	Topsoil. Dark greyish brown moderately compact silty clay		
37901	Layer				Natural. Mid greyish orange compact clay		
37902	Unexcavated feature				Ditch		
37903	Cut		1.7	0.43	Ditch		
37904	Fill	37903	1.7	0.43	Primary Fill. Mid orangey blue. Silty clay. Possible bioturbation present.		
Trench 380							
General description						Orientation	E-W
Devoid of archaeology. Trench consists of ploughsoil onto clay natural						Length (m)	30
						Width (m)	2
						Avg. depth (m)	0.35
Context No.	Type	Fill Of	Width (m)	Depth (m)	Description	Finds	Date
38000	Layer			0.35	Topsoil. Dark greyish brown moderately compact silty clay		
38001	Layer				Natural. Light yellowish orange clay		
Trench 381							
General description						Orientation	N-S
Consists ploughsoil overlying brick earth type deposit, then natural London clay. No archaeology present.						Length (m)	30
						Width (m)	2
						Avg. depth (m)	1
Context No.	Type	Fill Of	Width (m)	Depth (m)	Description	Finds	Date
38100	Layer			0.31	Ploughsoil. Dark greyish brown moderately compact silty clay		

38101	Layer			0.55	Colluvial Layer. Mid orange brown clay silt. Head deposit.		
38102	Layer				Natural. Mid orange grey silt clay.		
Trench 382							
General description						Orientation	E-W
Trench consists of ploughsoil overlying the natural clay. Two ditches identified.						Length (m)	30
						Width (m)	1.8
						Avg. depth (m)	0.3
Context No.	Type	Fill Of	Width (m)	Depth (m)	Description	Finds	Date
38200	Layer			0.3	Ploughsoil. Mid greyish brown. Silty clay		
38201	Layer				Natural. Mid orange brown. Clayey clay		
38202	Cut		2.4	0.68	Ditch		
38203	Fill	38202	0.24	0.2	Primary Fill. Mid reddish grey, clay		
38204	Fill	38202	0.35	0.4	Secondary Fill. Mid bluey grey, clay		
38205	Fill	38202	2.4	0.68	Secondary Fill. Mid yellowish grey, silty clay	Pottery CBM	RB undated
38206	Cut		0.64	0.42	Ditch		
38207	Fill	38206	0.64	0.42	Secondary Fill	Pottery	13th – E15th C
Trench 383							
General description						Orientation	EW
Trench contains one tree throw. Consists of ploughsoil directly onto clay natural						Length (m)	30
						Width (m)	2
						Avg. depth (m)	0.5
Context No.	Type	Fill Of	Width (m)	Depth (m)	Description	Finds	Date
38300	Layer			0.5	Ploughsoil. Dark blackish brown silty clay		
38301	Layer				Natural. Mid reddish brown clay		
38302	Cut		1.96	0.4	Tree Throw		
38303	Fill	38302	1.96	0.2	Primary Fill. Light grey brown. Silty clay.		
38304	Void						
Trench 384							
General description						Orientation	NS
Trench devoid of archaeology. Consists of ploughsoil directly onto clay natural						Length (m)	30
						Width (m)	2
						Avg. depth (m)	0.5

Context No.	Type	Fill Of	Width (m)	Depth (m)	Description	Finds	Date
38400	Layer			0.5	Ploughsoil. Dark blackish brown silty clay		
38401	Layer				Natural. Mid reddish brown clay		
Trench 385							
General description					Orientation	E-W	
Trench devoid of Archaeology					Length (m)	30	
					Width (m)	2	
					Avg. depth (m)	0.35	
Context No.	Type	Fill Of	Width (m)	Depth (m)	Description	Finds	Date
38500	Layer			0.35	Topsoil. Dark greyish brown moderately compact silty clay		
38501	Layer				Natural. Light greyish yellow compact clay. More grey on W side. Occasional gravel		
Trench 386							
General description					Orientation	NS	
Trench devoid of archaeology. Consists of ploughsoil onto clay natural					Length (m)	30	
					Width (m)	2	
					Avg. depth (m)	0.4	
Context No.	Type	Fill Of	Width (m)	Depth (m)	Description	Finds	Date
38600	Layer			0.4	Ploughsoil. Dark blackish brown silty clay		
38601	Layer				Natural. Mid reddish brown with some gravel		
Trench 387							
General description					Orientation	EW	
Trench devoid of archaeology. Consists of ploughsoil onto clay natural					Length (m)	30	
					Width (m)	2	
					Avg. depth (m)	0.5	
Context No.	Type	Fill Of	Width (m)	Depth (m)	Description	Finds	Date
38700	Layer			0.5	Ploughsoil. Dark blackish brown silty clay		
38701	Layer				Natural. Mid orangeish brown clay		
Trench 388							
General description					Orientation	N-S	
Trench contains 1 ditch. Consists of ploughsoil onto clay natural					Length (m)	30	

						Width (m)	2
						Avg. depth (m)	0.35
Context No.	Type	Fill Of	Width (m)	Depth (m)	Description	Finds	Date
38800	Layer			0.35	Topsoil. Dark greyish brown moderately compact silty clay		
38801	Layer				Natural. Light greyish orange compact clay		
38802	Cut		0.7	0.18	Ditch		
38803	Fill	38802	0.7	0.18	Primary Fill. Mid brown orange. Silty clay.		
38804	Cut				Natural Feature.		
Trench 389							
General description						Orientation	E-W
Trench uncovered a ditch. Consisted of ploughsoil overlying the natural clay geology.						Length (m)	30
						Width (m)	1.8
						Avg. depth (m)	0.4
Context No.	Type	Fill Of	Width (m)	Depth (m)	Description	Finds	Date
38900	Layer			0.4	Ploughsoil. Mid greyish brown. Silty clay.		
38901	Layer				Natural. Mid reddish brown. Clayey clay.		
38902	Cut		0.85	0.45	Ditch		
38903	Fill	38902	0.38	0.12	Primary Fill. Firm, dark blackish grey, silt clay, frequent charcoal flecks		
38904	Fill	38902	0.85	0.33	Secondary Fill. Firm, mottled medium greyish orange and medium greyish brown, silt clay, occasional charcoal flecks		
Trench 390							
General description						Orientation	NW-SE
Trench revealed One ditch, two gullies, one pit and one posthole. Consists of ploughsoil overlying natural geology.						Length (m)	30
						Width (m)	2
						Avg. depth (m)	0.33
Context No.	Type	Fill Of	Width (m)	Depth (m)	Description	Finds	Date
39000	Layer			0.33	Ploughsoil. Dark greyish brown silty clay.		
39001	Layer				Natural. Light reddish yellow silty clay.		
39002	Cut		0.12	0.05	Natural Feature. Rooting/ dark greyish brown silty clay fill.		
39003	Cut		2.65	c 0.7	Ditch		

39004	Fill	39003			Primary Fill. Dark brownish grey silty clay.		
39005	Fill	39003			Secondary Fill. Mottled greyish yellow silty clay.		
39006	Fill	39003			Tertiary Fill. Dark grey silty clay.		
39007	Cut		0.3	0.05	Gully		
39008	Fill	39007	0.3	0.05	Primary Fill. Mid blueish brown. Silty clay.		
39009	Cut		0.68	0.14	Probable gully		
39010	Fill	39009	0.68	0.14	Primary Fill. Mid blueish brown. Silty clay. Possible bioturbation.		
39011	Cut		1.14	0.15	Pit		
39012	Fill	39011	1.14	0.15	Primary Fill. Mid reddish grey. Silty clay. Charcoal rich.		
39013	Cut		0.3	0.3	Posthole		
39014	Fill	39013	0.3	0.3	Secondary Fill. Mid grey brown. Silty clay.		

Trench 391

General description						Orientation	NS
Trench devoid of archaeology. Consists of ploughsoil overlying clay natural						Length (m)	30
						Width (m)	2
						Avg. depth (m)	0.5
Context No.	Type	Fill Of	Width (m)	Depth (m)	Description	Finds	Date
39100	Layer			0.5	Ploughsoil. Dark blackish brown silty clay		
39101	Layer				Natural. Mid reddish brown clay		

Trench 392

General description						Orientation	E-W
Trench contains one small gully. Ploughsoil coming down directly on to natural. Field drain at eastern end.						Length (m)	30
						Width (m)	2
						Avg. depth (m)	0.3
Context No.	Type	Fill Of	Width (m)	Depth (m)	Description	Finds	Date
39200	Layer		2	0.3	Topsoil. Dark greyish brown loam.		
39201	Layer		2		Natural. Dark orangish. brown compact clay with little to no inclusions.		
39202	Cut		0.4	0.08	Gully		
39203	Fill	39202	0.4	0.08	Primary Fill. Mid grey brown. Silty clay.		

Trench 393							
General description						Orientation	E-W
Trench devoid of archaeology. Ploughsoil coming down directly on to natural. Field drain at eastern end.						Length (m)	30
						Width (m)	1.8
						Avg. depth (m)	0.5
Context No.	Type	Fill Of	Width (m)	Depth (m)	Description	Finds	Date
39300	Layer			0.5	Ploughsoil. Dark greyish brown loam.		
39301	Layer				Natural. Dark orangey brown compact clay with little to no inclusions.		
Trench 394							
General description						Orientation	NE-SW
Trench devoid of archaeology. Ploughsoil onto sequence of alluvium, bleached horizon and weathered bedrock. Trench excavated to 2m.						Length (m)	30
						Width (m)	6
						Avg. depth (m)	0.42
Context No.	Type	Fill Of	Width (m)	Depth (m)	Description	Finds	Date
39400	Layer			0.42	Topsoil. Dark greyish brown loam.		
39401	Layer			0.2	Alluvial Layer. Mid yellowish brown compact clay occasionally mottled with mid greyish blue compact clay.		
39402	Layer			0.3	Alluvial Layer. Dark greyish brown silty clay		
39403	Layer			0.14	Alluvial Layer. Dark greyish brown silty clay		
39404	Layer			0.12	Alluvial Layer. Mottled dark greyish brown clayey silt		
39405	Layer			0.2	Natural. Clayey bleached horizon.		
39406	Layer			0.11	Natural. Light grey sand clay. Bleached horizon		
39407	Layer			0.33	Natural. Mid reddish yellow clay with grey mottling weathered bedrock		
39408	Layer			0.17	Natural. Mottled Mid reddish yellow with light grey veins silty clay. Bedrock		
Trench 395							
General description						Orientation	E-W

Trench devoid of archaeology. Consists of ploughsoil and subsoil overlying natural clay.						Length (m)	30
						Width (m)	2
						Avg. depth (m)	0.7
Context No.	Type	Fill Of	Width (m)	Depth (m)	Description	Finds	Date
39500	Layer			0.5	Ploughsoil. Mid blackish brown silty clay		
39501	Layer			0.2	Subsoil. Mid yellowish brown clay with blue patches		
39502	Layer				Natural. Mid yellowish brown clay with lots of dark patches of rooting		

Trench 396							
General description						Orientation	NE SW
Trench devoid of archaeology. Consists of ploughsoil and subsoil overlying natural						Length (m)	30
						Width (m)	2
						Avg. depth (m)	1
Context No.	Type	Fill Of	Width (m)	Depth (m)	Description	Finds	Date
39600	Layer			0.5	Ploughsoil. Mid blackish brown silty clay		
39601	Layer			0.5	Subsoil. Mid yellowish brown clay		
39602	Layer				Natural. Mid yellowish brown clay with some dark smears		
Trench 397							
General description						Orientation	NE-SW
Devoid of archaeology. Topsoil alluvium with stabilisation horizon and bleached horizon with weathered bedrock base. Excavated to 2m.						Length (m)	30
						Width (m)	6
						Avg. depth (m)	0.45
Context No.	Type	Fill Of	Width (m)	Depth (m)	Description	Finds	Date
39700	Layer		6	0.45	Topsoil. Dark greyish brown loam.		
39701	Layer		6	0.2	Alluvial Layer. Mid yellowish brown compact clay occasionally mottled with mid greyish blue compact clay.		
39702	Layer		6	0.56	Natural. Weathered bedrock. Mid yellowish brown		

					compact clay with little to no inclusions.		
39703	Layer			0.24	Alluvial Layer. Firm mid brownish grey silty clay		
39704	Layer			0.22	Alluvial Layer. Firm mid yellowish brown clayey silt		
39705	Layer			0.04	Other Layer. Stabilisation horizon. Firm dark greyish brown silty clay		
39706	Layer			0.12	Alluvial Layer. Firm mid reddish brown clayey silt with grey mottling		
39707	Layer			0.06	Buried soil. Firm dark brown clayey silt. Humic rich		
39708	Layer			0.16	Natural. Bleached horizon. Firm pale brownish grey silty clay with fe oxidised mottled		

Trench 398

General description						Orientation	E-W
Trench devoid of archaeology. Consists of ploughsoil and subsoil overlying natural clay						Length (m)	30
						Width (m)	2
						Avg. depth (m)	0.5

Context No.	Type	Fill Of	Width (m)	Depth (m)	Description	Finds	Date
39800	Layer			0.3	Ploughsoil. Mid blackish brown silty clay		
39801	Layer			0.2	Subsoil. Light yellowish brown clay with blue patches.		
39802	Layer				Natural. Mid yellowish brown clay with lots of dark patches of rooting		

Trench 399

General description						Orientation	NW SE
Trench devoid of archaeology. Consists of ploughsoil overlying natural clay						Length (m)	30
						Width (m)	2
						Avg. depth (m)	0.6

Context No.	Type	Fill Of	Width (m)	Depth (m)	Description	Finds	Date
-------------	------	---------	-----------	-----------	-------------	-------	------

39900	Layer			0.3	Ploughsoil. Mid blackish brown silty clay		
39901	Layer			0.3	Subsoil. Light yellowish brown clay with blue patches.		
39902	Layer				Natural. Mid yellowish brown clay with lots of dark patches of rooting		

Trench 400

General description						Orientation	E-W
Trench devoid of archaeology. Consists of ploughsoil overlying alluvium which covers a thin stabilisation horizon. Thus overlies more alluvium and a pale grey silty deposit which overlies weathered London Clay. Excavated to 2m.						Length (m)	30
						Width (m)	6
						Avg. depth (m)	2

Context No.	Type	Fill Of	Width (m)	Depth (m)	Description	Finds	Date
40000	Layer			0.26	Ploughsoil. Dark greyish brown clayey silt		
40001	Layer			0.26	Alluvial Layer. Light yellowish brown silty clay with dark patches of rooting		
40002	Layer			0.06	Buried soil. Very dark greyish brown to black, humic, clayey silt. Stabilisation horizon		
40003	Layer			0.17	Alluvial Layer. Mid brownish grey silty clay		
40004	Layer			0.07	Other Layer. Pale whiteish grey silt. Possible marl-like deposit		
40005	Layer			0.46	Natural. Mid yellowish brown silty clay. Possible weathered London Clay		
40006	Layer			0.04	Natural. Light yellowish brown silty clay. Weathered horizon within weathered London Clay		
40007	Layer				Natural. Dark yellowish to reddish brown silty clay. London Clay bedrock		

Trench 401							
General description						Orientation	NE SW
Trench devoid of archaeology. Consists of ploughsoil and subsoil overlying natural clay.						Length (m)	30
						Width (m)	2
						Avg. depth (m)	1
Context No.	Type	Fill Of	Width (m)	Depth (m)	Description	Finds	Date
40100	Layer			0.3	Ploughsoil. Dark blackish brown silty clay		
40101	Layer			0.5	Subsoil. Mid grayish brown clay		
40102	Layer				Natural. Mid reddish brown clay		
Trench 402							
General description						Orientation	E-W
Trench devoid of archaeology, consisting of ploughsoil and subsoil overlying natural geology of clay.						Length (m)	30
						Width (m)	6
						Avg. depth (m)	1.2
Context No.	Type	Fill Of	Width (m)	Depth (m)	Description	Finds	Date
40200	Layer			0.25	Ploughsoil. Dark greyish brown, silty clay.		
40201	Layer			0.15	Subsoil. Light grey silty clay.		
40202	Layer				Natural. Pale orangey brown clay. Headland deposit.		
Trench 403							
General description						Orientation	NE-SW
Ploughsoil overlying alluvium and possible stabilisation layer. This is followed by another two alluviums overlying a couple of brickearth type deposits. Trench not bottomed to bedrock. Trench devoid of archaeology. Excavated to 2m.						Length (m)	30
						Width (m)	6
						Avg. depth (m)	0.75
Context No.	Type	Fill Of	Width (m)	Depth (m)	Description	Finds	Date
40300	Layer			0.49	Ploughsoil. Dark greyish brown slightly silty clay		
40301	Layer			0.2	Alluvial Layer. Mid yellowish brown mottled by mid greyish brown, silty clay.		
40302	Layer			0.06	Other Layer. Black. Mottled by dark yellowish brown, slightly silty clay		
40303	Layer			0.2	Alluvial Layer. Strong brown mottled with mid yellowish brown		

					and oxidisation some pale grey mottling in areas. Silty clay		
40304	Layer			0.15	Alluvial Layer. Pale grey mottled by light yellow, clayey silt		
40305	Layer			0.25	Other Layer. Brickearth type deposit Mid reddish brown mottled by mid greyish brown slightly silty clay		
40306	Layer			0.49	Other Layer. Dark reddish brown mottled by mid greyish brown, clay		

Trench 404

General description					Orientation	E-W	
Trench devoid of archaeology, consisting of ploughsoil and subsoil overlying natural alluvial layers and London Clay natural.					Length (m)	30	
					Width (m)	6	
					Avg. depth (m)	0.5	
Context No.	Type	Fill Of	Width (m)	Depth (m)	Description	Finds	Date
40400	Layer			0.2	Ploughsoil. Dark greyish brown, silty clay.		
40401	Layer			0.3	Subsoil. Mid blueish grey, silty clay.		

Trench 405

General description					Orientation	NE-SW	
Trench devoid of archaeology. Consists of ploughsoil overlying alluvium which covers a thin stabilisation horizon. This overlies more alluvium and weathered London Clay					Length (m)	30	
					Width (m)	6	
					Avg. depth (m)	2	
Context No.	Type	Fill Of	Width (m)	Depth (m)	Description	Finds	Date
40500	Layer		6	0.22	Ploughsoil. Dark greyish brown silty clay		
40501	Layer		6	0.2	Alluvial Layer. Mid greyish brown silty clay		
40502	Layer		6	0.3	Alluvial Layer. Mid brown grey, silty		
40503	Layer			0.21	Alluvial Layer. Light yellow brown silty clay		
40504	Layer		6	0.07	Other Layer. Dark grey black silty clay		
40505	Layer		6	0.32	Alluvial Layer. Mid grey brown with mottled yellow brown bands		

40506	Layer		6	0.17	Other Layer. Mid grey brown clay silt, bands of yellow brown, Weathered bedrock		
40507	Layer		6		Other Layer. Mid brown grey clayey silt, weathered bedrock		

Trench 406

General description						Orientation	NE-SW
Trench contains some worked flints (though not in scatters). Consists of ploughsoil and subsoil overlying possible alluvium but probable head deposits which overlie London Clay bedrock. Excavated to a max depth of approx 1.3m (due to reaching bedrock).						Length (m)	30
						Width (m)	6
						Avg. depth (m)	0.67
Context No.	Type	Fill Of	Width (m)	Depth (m)	Description	Finds	Date
40600	Layer			0.3	Ploughsoil. Dark greyish brown clayey silt		
40601	Layer			0.1	Subsoil. Mid greyish brown silty clay with frequent Fe mottling		
40602	Layer			0.1	Alluvial Layer. Light greyish brown sandy silt. Possible alluvium		
40603	Layer			0.1	Alluvial Layer. Light bluish grey sandy silt with frequent Fe mottling containing a few worked flints. Possible alluvium.	Flint	
40604	Layer			0.3	Natural. Mid yellowish brown clayey silt with frequent small pebbles and granules. Head deposit		
40605	Layer			0.2	Natural. Mid yellowish to reddish brown sandy clay with bands of matrix supported sub-angular gravels. Head deposit		
40606	Layer				Natural. Compact mid reddish brown silty clay. Weathered London Clay bedrock		

Trench 407

General description						Orientation	NE-SW
						Length (m)	30

Trench devoid of archaeology. Consisted of ploughsoil and an alluvial layer overlying the natural London clay geology. Excavated to a total depth of 1.7m						Width (m)	6
						Avg. depth (m)	0.35
Context No.	Type	Fill Of	Width (m)	Depth (m)	Description	Finds	Date
40700	Layer			0.2	Ploughsoil. Dark brown, silty clay.		
40701	Layer			0.15	Alluvial Layer. Mid brownish grey, clayey clay.		
40702	Layer				Natural. Light yellowish brown clay.		
Trench 408							
General description						Orientation	N-S
Trench devoid of archaeology. Consisted of ploughsoil overlying possible alluvial context. Underlying this is a head deposit on top of natural London clay. Excavated to 2m.						Length (m)	30
						Width (m)	
						Avg. depth (m)	
Context No.	Type	Fill Of	Width (m)	Depth (m)	Description	Finds	Date
40800	Layer			0.36	Ploughsoil. Dark greyish brown. Silty clay.		
40801	Layer			0.29	Alluvial Layer. Light yellowish brown. mottled with light grey Clayey silt.		
40802	Layer			0.36	Other Layer. Dark reddish brown mottled with mid grey and mid reddish brown oxidisation with chalk inclusions. Silty clay		
40803	Layer			0.27	Natural. Mid reddish brown mottled with mid grey. Clay		
Trench 409							
General description						Orientation	NE-SW
Pit present at NE end of trench. Worked flints collected from layer (40901). Consists of ploughsoil and alluvial layer overlying silty clay and gravel natural. Excavated to a max depth of 1m.						Length (m)	30
						Width (m)	2
						Avg. depth (m)	0.65
Context No.	Type	Fill Of	Width (m)	Depth (m)	Description	Finds	Date
40900	Layer			0.42	Ploughsoil. Dark greyish brown clayey silt		
40901	Layer			0.18	Subsoil. Mid greyish yellow sandy clay containing worked flint	Flint	

40902	Layer				Natural. Mid orangish brown silty clay with patches of gravel		
40903	Cut		0.74	0.24	Pit		
40904	Fill	40903	0.62	0.18	Primary Fill. Compact/hard, med brownish grey, silt clay (slight patches of sand), very frequent pottery fragments. Sampled 111	Pottery Flint	MBA
40905	Fill	40903	0.73	0.06	Secondary Fill. Hard, medium yellowish brown, silty clay (powdery), occasional charcoal flecks.		
40906	Fill	40903	0.59	0.06	Tertiary Fill. Compact, mottled greyish white, silt clay, moderate charcoal flecks throughout fill		

Trench 410

General description	Orientation	E-W
Trench devoid of archaeology. Consists of ploughsoil and subsoil overlying clay	Length (m)	30
	Width (m)	2
	Avg. depth (m)	0.55

Context No.	Type	Fill Of	Width (m)	Depth (m)	Description	Finds	Date
41000	Layer			0.2	Ploughsoil. Dark greyish brown silty clay		
41001	Layer			0.2	Subsoil. Mid greyish brown silty clay		
41002	Layer				Natural. Mid yellowish brown clay		
41003	Void						

Trench 411

General description	Orientation	NE-SW
Trench devoid of archaeology. Consists of ploughsoil and subsoil overlying clayey head and London Clay bedrock.	Length (m)	30
	Width (m)	2
	Avg. depth (m)	1

Context No.	Type	Fill Of	Width (m)	Depth (m)	Description	Finds	Date
41100	Layer			0.28	Ploughsoil. Dark greyish brown clayey silt		
41101	Layer			0.08	Subsoil. Light greyish brown		

					clayey silt. Subsoil / interface		
41102	Layer			0.21	Natural. Compact, light yellowish brown clayey silt. Head deposit		
41103	Layer			0.18	Natural. Compact, mid blueish grey clayey silt. Head deposit		
41104	Layer				Natural. Firm, mid yellowish brown silty clay. Weathered London Clay		

Trench 412

General description						Orientation	E-W
Trench devoid of archaeology. Consisted of ploughsoil overlying the natural clay geology. The London clay appeared at 0.85 m of depth, therefore we stopped the stripping over there.						Length (m)	30
						Width (m)	1.8
						Avg. depth (m)	1

Context No.	Type	Fill Of	Width (m)	Depth (m)	Description	Finds	Date
41200	Layer			0.3	Ploughsoil. Dark brown, silty clay. Friable texture.		
41201	Layer				Alluvial Layer. Mid orangey yellow with bluish grey patches of manganese. Compacted texture. It's overlying the natural geology formed by the "London clay" (41202).		
41202	Layer				Natural. Mid reddish brown with calcareous flecks with yellowish white hue. Quite compacted texture. Also known as "London clay", it appeared at a depth of 0.85 m.		

Trench 413

General description						Orientation	N-S
Trench devoid of archaeology. Consisted of ploughsoil and subsoil overlying natural geology of clay.						Length (m)	30
						Width (m)	2
						Avg. depth (m)	0.5

Context No.	Type	Fill Of	Width (m)	Depth (m)	Description	Finds	Date
-------------	------	---------	-----------	-----------	-------------	-------	------

41300	Layer			0.2	Ploughsoil. Dark greyish brown silty clay		
41301	Layer			0.2	Subsoil. Mid brownish grey silty clay		
41302	Layer				Natural. Mid yellowish brown clay		
Trench 414							
General description						Orientation	E-W
Trench devoid of archaeology. Consisted of ploughsoil and alluvial layer overlying the natural clay geology.						Length (m)	30
						Width (m)	1.8
						Avg. depth (m)	1
Context No.	Type	Fill Of	Width (m)	Depth (m)	Description	Finds	Date
41400	Layer			0.32	Ploughsoil. Dark brown, silty clay. Friable texture.		
41401	Layer			0.45	Alluvial Layer. Mid orangey yellow with patches of bluish grey of manganese. Compacted texture.		
41402	Layer				Natural. Mid reddish brown with calcareous flecks with yellowish white hue. It's also known as "London clay".		

Trench 415							
General description						Orientation	N-S
Trench devoid of archaeology. Consisted of ploughsoil and alluvial layer overlying the natural clay geology.						Length (m)	30
						Width (m)	2
						Avg. depth (m)	1
Context No.	Type	Fill Of	Width (m)	Depth (m)	Description	Finds	Date
41500	Layer			0.35	Ploughsoil. Dark brown, silty clay. Friable texture.		
41501	Layer			0.45	Alluvial Layer. Mid orangey yellow clayey clay with patches of bluish grey manganese. Compacted texture.		
41502	Layer				Natural. Mid reddish brown clayey clay with some calcareous flecks with yellowish white hue. Compacted		

					texture. Also known as "London clay".							
Trench 416												
General description						Orientation	E-W					
Trench devoid of archaeology. Consists of ploughsoil and subsoil overlying natural geology of clay.						Length (m)	30					
						Width (m)						2
						Avg. depth (m)						0.43
Context No.	Type	Fill Of	Width (m)	Depth (m)	Description	Finds	Date					
41600	Layer		2	0.2	Ploughsoil. Dark greyish brown silty clay							
41601	Layer		2	0.2	Ploughsoil. Mid brownish grey silty clay							
41602	Layer		2		Natural. Mid yellowish brown clay							
Trench 417												
General description						Orientation	N-S					
Consisted of ploughsoil and alluvial layer overlying natural clay geology. Investigation revealed no archaeology present.						Length (m)	30					
						Width (m)						1.8
						Avg. depth (m)						1
Context No.	Type	Fill Of	Width (m)	Depth (m)	Description	Finds	Date					
41700	Layer			0.3	Ploughsoil. Dark brown, silty clay. Friable texture.							
41701	Layer			0.4	Alluvial Layer. Mid orangey yellow with patches of bluish grey manganese. Compacted texture. Is overlying the natural geology conformed by the "London clay".							
41702	Layer				Natural. Mid reddish brown with calcareous flecks with yellowish white hue. Quite compacted.							
41703	Cut		1.28	0.26	Natural Feature. Natural feature with dark mixed fills and lots of rooting - possibly a tree throw with burning.							
Trench 418												
General description						Orientation	NE-SW					
Trench devoid of archaeology. Consisted of ploughsoil and alluvial layer overlying the natural clay geology. Excavated to a total depth of 1.5m upon reaching London Clay.						Length (m)	30					
						Width (m)						6
						Avg. depth (m)						0.83

Context No.	Type	Fill Of	Width (m)	Depth (m)	Description	Finds	Date
41800	Layer			0.35	Ploughsoil. Dark brown, silty clay.		
41801	Layer			0.48	Alluvial Layer. Mid reddish yellow silty clay with bluish grey patches.		
41802	Layer				Natural. Mid reddish brown silty clay with yellow mottling.		

Trench 419

General description	Orientation	E-W
---------------------	-------------	-----

1 ditch. Ploughsoil and subsoil onto natural clay	Length (m)	30
	Width (m)	2
	Avg. depth (m)	0.5

Context No.	Type	Fill Of	Width (m)	Depth (m)	Description	Finds	Date
41900	Layer			0.41	Ploughsoil. Mid greyish brown, silty clay, firm		
41901	Layer			0.15	Subsoil. Light greyish yellow, silty clay, compact		
41902	Layer				Natural. Mid reddish brown silty clay, compact		
41903	Cut		1.38	0.2	Ditch		
41904	Fill	41903	1.38	0.2	Secondary Fill. Light brownish grey with orange mottling, silty clay compact		

Trench 420

General description	Orientation	N-S
---------------------	-------------	-----

Trench devoid of archaeology. Consisted of ploughsoil overlying the natural clay geology.	Length (m)	30
	Width (m)	1.8
	Avg. depth (m)	0.6

Context No.	Type	Fill Of	Width (m)	Depth (m)	Description	Finds	Date
42000	Layer			0.4	Ploughsoil. Mid greyish brown. Silty clay.		
42001	Layer			0.21	Subsoil. Mid orange brown. Clayey clay.		
42002	Layer				Natural. Mid reddish brown with gravel inclusions. Clayey clay.		

Trench 421

General description	Orientation	E-W
---------------------	-------------	-----

	Length (m)	30
	Width (m)	6

Trench devoid of archaeology. Consisted of ploughsoil and subsoil overlying possible alluvium and head deposits that overlie London Clay geology.						Avg. depth (m)	0.5
Context No.	Type	Fill Of	Width (m)	Depth (m)	Description	Finds	Date
42100	Layer				Ploughsoil. Mid greyish brown. Silty clay.		
42101	Layer				Natural. Mid orange brown. Clayey clay.		
42102	Layer				Natural. Dark greyish brown with white and yellow inclusions. Clayey clay.		
Trench 422							
General description						Orientation	E-W
Possible pit/tree bole. Tested - is a natural feature. Trench consisted of ploughsoil overlying the natural clay geology.						Length (m)	30
						Width (m)	6
						Avg. depth (m)	2
Context No.	Type	Fill Of	Width (m)	Depth (m)	Description	Finds	Date
42200	Layer			0.32	Topsoil. Dark greyish brown moderately compact silty clay		
42201	Layer				Natural. Light greyish yellow compact clay		
Trench 423							
General description						Orientation	N-S
Trench devoid of archaeology. Consisted of ploughsoil and subsoil overlying possible alluvium and head deposits with overlie London Clay geology.						Length (m)	30
						Width (m)	6
						Avg. depth (m)	0.5
Context No.	Type	Fill Of	Width (m)	Depth (m)	Description	Finds	Date
42300	Layer			0.3	Ploughsoil. Dark brown silty clay. Friable texture, the thick fraction (10%) contains gravels (1mm-1cm), sub-rounded limestones (1cm-5cm) and some flint nodules (1cm-5cm).		
42301	Layer			0.25	Subsoil. Mid greyish brown silty clay. Compacted texture, the thick fraction (10%) contains gravels (1mm-1cm), sub-rounded limestones (1cm-5cm) and some flint nodules (1cm-5cm).		
42302	Layer				Natural. Light yellowish brown clay. Quite		

					compacted texture. The thick fraction (25%) contains patches of yellowish sandy gravels (1mm-1cm), white flecks of calcareous as result of water activity(1cm-5cm) and some flint nodules (1cm-5cm). It has also a couple of charcoal spots as consequence of the rooting spreading.		
--	--	--	--	--	--	--	--

Trench 424

General description					Orientation	E-W	
Trench devoid of archaeology. Consisted of ploughsoil overlying the natural clay geology.					Length (m)	30	
					Width (m)	6	
					Avg. depth (m)	0.6	
Context No.	Type	Fill Of	Width (m)	Depth (m)	Description	Finds	Date
42400	Layer			0.36	Ploughsoil. Mid greyish brown. Silty clay.		
42401	Layer			0.31	Subsoil. Light greyish white. Sandy clay.		
42402	Layer				Natural. Mid yellowish brown. Clayey clay.		
42403	Layer				Natural. Dark reddish brown with chalk inclusions. Clayey clay.		

Trench 425

General description					Orientation	N-S	
Trench devoid of archaeology. Consists of ploughsoil and subsoil overlying alluvium and the natural clay deposits. Excavated to a total depth of 2m.					Length (m)	30	
					Width (m)	6	
					Avg. depth (m)		
Context No.	Type	Fill Of	Width (m)	Depth (m)	Description	Finds	Date
42500	Layer		6	0.29	Ploughsoil. Dark brown silty clay.		
42501	Layer			0.19	Subsoil. Mid greyish brown silty clay.		
42502	Layer			0.2	Alluvial Layer. Light bluish grey silty clay.		
42503	Layer				Natural. Mid reddish brown silty clay.		

Trench 426

General description					Orientation	E-W
Trench devoid of archaeology. Consisted of ploughsoil and subsoil overlying alluvium and the natural clay geology.					Length (m)	30
					Width (m)	6

						Avg. depth (m)	2
Context No.	Type	Fill Of	Width (m)	Depth (m)	Description	Finds	Date
42600	Layer			0.29	Ploughsoil. Dark greyish brown silty clay.		
42601	Layer			0.23	Subsoil. Mid greyish brown silty clay.		
42602	Layer			0.2	Alluvial Layer. Light bluish grey silty clay.		
42603	Layer				Natural. Mid bluish brown clay.		
42604	Cut				Natural Feature		

Trench 427

General description	Orientation	N-S
---------------------	-------------	-----

Trench contained one pit. Consisted of ploughsoil overlying the natural clay geology. Excavated to 1.8m.	Length (m)	30
	Width (m)	6
	Avg. depth (m)	

--	--	--

Context No.	Type	Fill Of	Width (m)	Depth (m)	Description	Finds	Date
42700	Layer			0.3	Ploughsoil. Dark grey brown clay silt.		
42701	Layer			0.1	Subsoil. Mid grey brown clay silt.		
42702	Layer			0.16	Alluvial Layer. Dark yellow brown silt clay.		
42703	Cut		1.75	0.28	Pit		
42704	Fill	42703	1.1	0.03	Primary Fill. Light blueish grey, silty clay, compact		
42705	Fill	42703	1.55	0.12	Secondary Fill. Mid brownish grey, silty clay compact		
42706	Fill	42703	1.75	0.12	Secondary Fill. Dark brownish grey silty clay compact		
42707	Layer			0.22	Alluvial Layer. Light blue grey clay silt.		
42708	Layer			0.14	Alluvial Layer. Mid grey brown silt clay.		
42709	Layer			0.58	Alluvial Layer. Dark yellow brown silt clay. Weathered London Clay.		
42710	Layer				Natural. Dark yellow slightly purple silt clay. London Clay.		

Trench 428

General description	Orientation	NW SE
---------------------	-------------	-------

Trench devoid of archaeology. Consists of ploughsoil and subsoil overlying natural clay	Length (m)	30
	Width (m)	6
	Avg. depth (m)	1.7

--	--	--

Context No.	Type	Fill Of	Width (m)	Depth (m)	Description	Finds	Date
42800	Layer			0.5	Ploughsoil. Mid blackish brown silty clay		
42801	Layer			0.3	Subsoil. Light grayish brown silty clay		
42802	Layer				Natural. Mid reddish brown clay with blue patches and white inclusions. Underneath there is blueish grey clay with some white inclusions		

Trench 429

General description					Orientation	EW
Trench devoid of archaeology. Consists of ploughsoil overlying London clay					Length (m)	30
					Width (m)	6
					Avg. depth (m)	1.5

Context No.	Type	Fill Of	Width (m)	Depth (m)	Description	Finds	Date
42900	Layer			0.5	Ploughsoil. Mid blackish brown silty clay		
42901	Layer				Natural. Mid reddish brown clay with blue patches and white inclusions overlying more grayish brown clay with white inclusions		

Trench 430

General description					Orientation	N-S
Trench devoid of archaeology. Consists of ploughsoil and thin layer of alluvium covering a thin buried soil/ stabilisation horizon that overlies more alluvial layers that overlie London Clay. Tree throw tested, lots of rooting.					Length (m)	30
					Width (m)	6
					Avg. depth (m)	0.3

Context No.	Type	Fill Of	Width (m)	Depth (m)	Description	Finds	Date
43000	Layer			0.27	Ploughsoil. Dark greyish brown clayey silt		
43001	Layer			0.09	Alluvial Layer. Mid orangey grey clayey silt with frequent iron mottling		
43002	Layer			0.05	Buried soil. Very dark greyish brown to black clayey silt with orange iron mottling. Stabilisation horizon		
43003	Layer			0.15	Alluvial Layer. Mid brownish grey silty clay		

					with frequent orange iron mottling		
43004	Layer			0.21	Alluvial Layer. Pale whiteish grey silt with charcoal flecks and orange iron mottling		
43005	Layer			0.2	Alluvial Layer. Mid greyish brown silty clay, mottled, with abundant orange iron mottling		
43006	Layer			0.46	Natural. Mid greyish brown silty clay. Weathered London Clay		
43007	Layer				Natural. Mid greyish brown to mid grey silty clay with light blueish grey clay patches. London Clay bedrock		
Trench 431							
General description						Orientation	NS
Trench devoid of archaeology. Consists of ploughsoil overlying London clay						Length (m)	30
						Width (m)	6
						Avg. depth (m)	2
Context No.	Type	Fill Of	Width (m)	Depth (m)	Description	Finds	Date
43100	Layer			0.6	Ploughsoil. Mid blackish brown silty clay		
43101	Layer				Natural. Mid reddish brown clay with blue patches and white inclusions More grayish blue layer with white inclusions underneath at 2m		
43102	Void						
Trench 432							
General description						Orientation	EW
Trench devoid of archaeology. Consists of ploughsoil overlying London clay						Length (m)	30
						Width (m)	6
						Avg. depth (m)	1.6
Context No.	Type	Fill Of	Width (m)	Depth (m)	Description	Finds	Date
43200	Layer			0.5	Ploughsoil. Mid blackish brown silty clay		
43201	Layer				Natural. Mid reddish brown clay with blue patches and white inclusions. Blueish grey clay with white		

					inclusions underneath at 2m		
Trench 433							
General description						Orientation	EW
Trench devoid of archaeology. Consists of ploughsoil overlying a thin alluvial layer that covers a thin buried soil / stabilisation horizon. This overlies another alluvial layer which also covers a second buried soil / stabilisation horizon. Underneath this is more alluvium and a pale whitish grey silt. There is a possible buried soil / stabilisation horizon beneath this; however, this may be disturbance from a nearby land drain. This overlies further alluvium that covers weathered London Clay.						Length (m)	30
						Width (m)	6
						Avg. depth (m)	2
Context No.	Type	Fill Of	Width (m)	Depth (m)	Description	Finds	Date
43300	Layer			0.25	Ploughsoil. Dark greyish brown clayey silt		
43301	Layer			0.04	Alluvial Layer. Dark yellowish brown clayey silt		
43302	Layer			0.03	Buried soil. Very dark greyish brown clayey silt with frequent organic matter. Thin stabilisation horizon		
43303	Layer			0.15	Alluvial Layer. Mid to dark yellowish brown clayey silt		
43304	Layer			0.04	Buried soil. Dark greyish brown, slightly purpleish clayey silt. Thin, diffuse, stabilisation horizon		
43305	Layer			0.08	Alluvial Layer. Mid greyish brown clayey silt		
43306	Layer			0.13	Alluvial Layer. Pale whiteish grey silt. Possible marl-like deposit		
43307	Layer			0.08	Buried soil. Dark yellowish brown clayey silt. Possible disturbance from nearby land drain		
43308	Layer			0.42	Alluvial Layer. Stiff mid greyish brown clayey silt with abundant iron mottling		
43309	Layer			0.33	Natural. Mid yellowish, slightly reddish brown silty clay. Weathered London Clay		
43310	Layer			0.05	Natural. Mid to light brownish grey silty clay. Weathered London Clay horizon		

43311	Layer				Natural. Compact mid yellowish to reddish brown silty clay with frequent sandy patches. London Clay bedrock		
-------	-------	--	--	--	---	--	--

Trench 434							
General description						Orientation	NE-SW
Trench devoid of archaeology. Consisted of ploughsoil, alluvium and stabilisation horizon overlying alluviums and then natural clay and sand/ gravel geology.						Length (m)	31
						Width (m)	6
						Avg. depth (m)	2
Context No.	Type	Fill Of	Width (m)	Depth (m)	Description	Finds	Date
43400	Layer			0.24	Ploughsoil. Dark grey brown clayey silt, friable		
43401	Layer			0.1	Alluvial Layer. Firm mottled mid reddish brown silty clay		
43402	Layer			0.42	Natural. Light yellowish brown clayey clay. Quite compacted texture. The thick fraction (25%) contains patches of yellowish sandy gravels (1mm-1cm), white flecks of calcareous as result of water activity(1cm-5cm) and some flint nodules (1cm-5cm). This sandy clay layer is overlying also another natural layer formed, mainly, by sand. It has also two charcoal spots as consequence of the rooting spreading.		
43403	Layer			0.04	Buried soil. Firm very dark brown clayey silt		
43404	Layer			0.1	Alluvial Layer. Firm mottled mid reddish brown silty clay		
43405	Layer			0.34	Alluvial Layer. Firm mid brownish grey silty clay		
43406	Layer			0.34	Natural. Soft/friable pale brownish grey very slightly clayey Sandy silt. Bleached horizon/ brick earth type deposits		

43407	Layer			0.24	Natural. Firm mottled mid reddish brown silty clay		
43408	Layer			0.33	Natural. Soft mid reddish brown silty clay with bluish grey veins. Weathered bedrock		
Trench 435							
General description						Orientation	E-W
Trench devoid of archaeology, consisting of plough soil overlying sequences of alluvium before hitting weathered bedrock. Excavated to 1.5m.						Length (m)	30
						Width (m)	6
						Avg. depth (m)	0.4
Context No.	Type	Fill Of	Width (m)	Depth (m)	Description	Finds	Date
43500	Layer			0.23	Ploughsoil. Dark greyish brown clayey silt		
43501	Layer			0.11	Alluvial Layer. Mid brownish grey clayey silt		
43502	Layer			0.06	Buried soil. Dark brownish grey clayey silt. Stabilisation horizon		
43503	Layer			0.1	Alluvial Layer. Mid greyish brown clayey silt		
43504	Layer			0.06	Buried soil. Dark purple brown clayey silt. Stabilisation horizon		
43505	Layer			0.13	Alluvial Layer. Mid greyish brown clayey silt with patches of light brown and light grey		
43506	Layer			0.15	Alluvial Layer. Light grey clayey silt with infrequent light brown patches.		
43507	Layer			0.06	Other Layer. Pale whiteish grey silt with infrequent flecks of organic material. Marl-like deposit	Flint	
43508	Layer			0.2	Natural. Mid greyish brown silty clay. Weathered London Clay		
43509	Layer				Natural. Compact greyish brown silty clay with light blueish grey patches. Weathered London Clay		

Trench 436							
General description						Orientation	E-W
Trench devoid of archaeology. Consisted of ploughsoil, subsoil and alluvial layers overlying the natural clay geology. Total depth of 2m.						Length (m)	30
						Width (m)	6
						Avg. depth (m)	1.09
Context No.	Type	Fill Of	Width (m)	Depth (m)	Description	Finds	Date
43600	Layer			0.28	Ploughsoil. Dark grey-brown clayey silt ploughsoil.		
43601	Layer			0.16	Subsoil. Light yellowish brown silty clay.		
43602	Layer			0.08	Other Layer. Dark blackish brown clayey sit. Peat?		
43603	Layer			0.12	Alluvial Layer. Mottled yellowish grey silty clay.		
43604	Layer			0.06	Other Layer. Dark blackish brown clayey silt. Peat?		
43605	Layer			0.39	Alluvial Layer. Mid grey silty clay.		
43606	Layer				Natural. Mid yellowish brown silty clay.		
Trench 437							
General description						Orientation	E-W
Trench devoid of archaeology. Consisted of ploughsoil overlying the natural clay geology.						Length (m)	30
						Width (m)	6
						Avg. depth (m)	2
Context No.	Type	Fill Of	Width (m)	Depth (m)	Description	Finds	Date
43700	Layer			0.35	Ploughsoil. Mid greyish brown. Silty clay.		
43701	Layer			0.11	Natural. Mid orange brown. Clayey clay.		
43702	Layer				Natural. Mid reddish brown with gravel inclusions. Clayey clay.		
Trench 438							
General description						Orientation	N-S
Trench devoid of archaeology. Consisted of ploughsoil overlying a sequence of alluvium resting on top of two layers of weathered bedrock.						Length (m)	30
						Width (m)	6
						Avg. depth (m)	1.4
Context No.	Type	Fill Of	Width (m)	Depth (m)	Description	Finds	Date

43800	Layer			0.22	Ploughsoil. Mid greyish brown. Silty clay.		
43801	Layer			0.22	Alluvial Layer. Mid yellowish brown. Silty clay.		
43802	Layer			0.22	Natural. Firm mid reddish brown with white chalk inclusions. Silty clay. Weathered bedrock		
43803	Layer			0.18	Alluvial Layer. Soft friable pale brownish grey slightly Sandy slightly clayey silt		
43804	Layer			0.18	Alluvial Layer. Firm light reddish brown silty clay		
43805	Layer			0.58	Natural. Weathered bedrock. Firm mid reddish brown silty clay with grey veins		
Trench 439							
General description						Orientation	E-W
Trench devoid of archaeology. Consisted of ploughsoil overlying the natural clay geology.						Length (m)	30
						Width (m)	6
						Avg. depth (m)	2
Context No.	Type	Fill Of	Width (m)	Depth (m)	Description	Finds	Date
43900	Layer			0.32	Ploughsoil. Mid greyish brown. Silty clay.		
43901	Layer			0.42	Subsoil. Mid orange brown with white inclusions. Clayey clay.		
43902	Layer				Natural. Dark reddish brown with white inclusions.		
Trench 440							
General description						Orientation	N-S
Trench devoid of archaeology and consists of ploughsoil overlying alluvial deposits that overlaid weathered London Clay						Length (m)	30
						Width (m)	6
						Avg. depth (m)	2
Context No.	Type	Fill Of	Width (m)	Depth (m)	Description	Finds	Date
44000	Layer			0.3	Ploughsoil. Dark greyish brown clayey silt		
44001	Layer			0.12	Alluvial Layer. Mid greyish brown silty clay		

44002	Layer			0.06	Alluvial Layer. Light greyish brown silty 3		
44003	Layer			0.04	Buried soil. Dark greyish brown to black, slightly humic, clayey silt. Stabilisation horizon		
44004	Layer			0.21	Alluvial Layer. Light greyish brown clayey silt		
44005	Layer			0.07	Alluvial Layer. Mid greyish brown clayey silt		
44006	Layer			0.35	Natural. Mid yellowish brown silty clay. Weathered London Clay		
44007	Layer			0.29	Natural. Compact, dark yellowish to mid reddish brown silty clay. Weathered London Clay		
44008	Layer			0.04	Natural. Firm, pale greyish white silty clay. Weathered horizon		
44009	Layer				Natural. Firm, mid reddish to dark yellowish brown silty clay. London Clay bedrock		

Trench 441

General description	Orientation	NE-SW
Trench devoid of archaeology and contains London Clay overlain by colluvium, subsoil and ploughsoil. Excavated to 1.5m.	Length (m)	30
	Width (m)	5
	Avg. depth (m)	0.79

Context No.	Type	Fill Of	Width (m)	Depth (m)	Description	Finds	Date
44100	Layer			0.3	Ploughsoil. Dark greyish brown clayey silt.		
44101	Layer			0.15	Subsoil. Mid greyish brown silty clay.		
44102	Layer			0.34	Alluvial Layer. Light bluish grey silty clay.		
44103	Layer				Natural. Mid reddish brown silty clay.		

Trench 442

General description	Orientation	N-S
Trench contains single gully roughly 1.2m down Ditch running E-W roughly 0.72m down. Excavated to 1.6m.	Length (m)	30
	Width (m)	6
	Avg. depth (m)	1

Context No.	Type	Fill Of	Width (m)	Depth (m)	Description	Finds	Date
44200	Layer			32	Topsoil. Dark grey brown. Silty clay.		
44201	Layer			32	Subsoil. Mid orangeish brown, silty clay.		
44202	Layer			54	Natural. Light orange grey, silty clay.		
44203	Cut		1.82	0.86	Ditch		
44204	Fill	44203	1.82	0.86	Secondary Fill. Firm, dark blackish grey, silty clay	CBM	

Trench 443

General description	Orientation	N-S
Trench revealed one ditch. Trench contains plough soil over sequence of alluvium layers with two stabilisation horizons.	Length (m)	30
	Width (m)	1.8
	Avg. depth (m)	0.4

Context No.	Type	Fill Of	Width (m)	Depth (m)	Description	Finds	Date
44300	Layer			0.22	Ploughsoil. Dark greyish brown silty clay.		
44301	Layer			0.06	Alluvial Layer. Firm mid yellowish brown silty clay		
44302	Layer				Natural. Orange-grey silty clay		
44303	Cut		1.86	0.47	Ditch. Present on OS map, continuation of ditch feature present in trench 442.		
44304	Fill	44303			Secondary Fill. Mid brownish orange silty clay	Cu object	
44305	Fill	44303			Secondary Fill. Dark brownish grey silty clay		
44306	Layer			0.04	Buried soil. Firm dark greyish brown silty clay. Stabilisation horizon		
44307	Layer			0.12	Alluvial Layer. Firm mid greyish brown clayey silt		
44308	Layer			0.04	Buried soil. Firm dark greyish brown silty clay. Stabilisation horizon		
44309	Layer			0.22	Alluvial Layer. Soft pale brownish grey clayey silt. Humic rich		
44310	Layer			0.12	Alluvial Layer. Soft brownish grey slightly Sandy slightly clayey silt		

Trench 444							
General description						Orientation	E-W
Trench consisted of ploughsoil overlying the natural clay geology. Excavated to 2m.						Length (m)	30
						Width (m)	6
						Avg. depth (m)	0.45
Context No.	Type	Fill Of	Width (m)	Depth (m)	Description	Finds	Date
44400	Layer			0.32	Ploughsoil. Mid greyish brown. Silty clay.		
44401	Layer			0.13	Subsoil. Light whiteish grey. Silty clay.		
44402	Layer				Natural. Mid orange brown. Clayey clay.		
44403	Layer				Natural. Mid reddish brown with white inclusions. Clayey clay.		
Trench 445							
General description						Orientation	N-S
A sequence of alluviums with two stabilisation horizon in between. A bleached horizon lying on top of weathered bedrock before hitting bedrock. Excavated to 2m.						Length (m)	30
						Width (m)	6
						Avg. depth (m)	1.4
Context No.	Type	Fill Of	Width (m)	Depth (m)	Description	Finds	Date
44500	Layer			0.28	Ploughsoil. Friable dark greyish brown silty clay		
44501	Layer			0.18	Alluvial Layer. Firm mid yellowish brown silty clay		
44502	Layer			0.04	Buried soil. Friable very dark brown silty clay. Stabilisation horizon		
44503	Layer			0.26	Alluvial Layer. Firm mid greyish brown silty clay		
44504	Layer			0.02	Buried soil. Soft dark greyish brown silty clay with organic material Stabilisation horizon		
44505	Layer			0.2	Alluvial Layer. Mid brownish grey silty clay	Pottery Fired clay	EIA?
44506	Layer			0.16	Alluvial Layer. Soft pale brownish grey clayey silt. Bleached horizon?		
44507	Layer			0.16	Natural. Soft mid reddish brown clayey silt. Weathered bedrock		

44508	Layer			0.18	Natural. Soft mid reddish brown silty clay. Weathered bedrock		
44509	Layer			0.08	Natural. Distinct Soft mid brown slightly clayey silt. Silt horizon		
44510	Layer			0.4	Natural. Firm mid brownish grey silty clay with bluish grey veins and calcium inclusions. Bedrock		

Trench 446

General description						Orientation	E-W
Trench devoid of archaeology. Trench consists of ploughsoil and subsoil overlying natural geology. Excavated to 1.2m.						Length (m)	30
						Width (m)	6
						Avg. depth (m)	0.46
Context No.	Type	Fill Of	Width (m)	Depth (m)	Description	Finds	Date
44600	Layer			0.28	Ploughsoil. Dark greyish brown clayey silt		
44601	Layer			0.18	Subsoil. Light greyish brown silty clay.		
44602	Layer				Natural. Mid reddish brown silty clay.		

Trench 447

General description						Orientation	N-S
Trench devoid of archaeology. Ploughsoil overlays natural geology of silty clay. Total depth 1.3m.						Length (m)	30
						Width (m)	6
						Avg. depth (m)	0.48
Context No.	Type	Fill Of	Width (m)	Depth (m)	Description	Finds	Date
44700	Layer			0.3	Ploughsoil. Dark greyish brown clayey silt.		
44701	Layer			0.18	Subsoil. Light brownish grey silty clay.		
44702	Layer				Natural. Mid yellowish brown silty clay.		

Trench 448

General description						Orientation	E-W
One ditch running N-S at the eastern end of the trench, a field drain running N-S at the western end. Trench consisted of ploughsoil and subsoil overlying natural clay geology.						Length (m)	30
						Width (m)	1.8
						Avg. depth (m)	1
Context No.	Type	Fill Of	Width (m)	Depth (m)	Description	Finds	Date
44800	Layer			0.2	Ploughsoil. Dark grey brown, silty clay.		

44801	Layer			0.3	Subsoil. Light yellow brown, silty clay.		
44802	Layer				Natural. Mid orange brown, clay.		
44803	Cut		0.89	0.31	Ditch		
44804	Fill	44803	0.89	0.31	Primary Fill. Moderately compact, medium bluish brown, clay silt, occasional small, rounded stones		

Trench 449

General description						Orientation	E-W
Trench consisted of ploughsoil , two alluviums a bleached horizon on top of weathered bedrock and London Clay						Length (m)	30
						Width (m)	6
						Avg. depth (m)	1.6
Context No.	Type	Fill Of	Width (m)	Depth (m)	Description	Finds	Date
44900	Layer			0.3	Ploughsoil. Dark grey brown, silty clay.		
44901	Layer			0.06	Alluvial Layer. Light yellow brown, silty clay.		
44902	Layer			0.12	Alluvial Layer. Firm mid brownish grey clayey silt		
44903	Layer			0.08	Natural. Bleached horizon. Firm pale reddish brown clayey silt.		
44904	Layer			0.72	Natural. Firm mid reddish brown silty clay Weathered bedrock		
44905	Layer			0.28	Natural. Firm mid greyish brown silty clay Bedrock		

Trench 450

General description						Orientation	N-S
Trench revealed two ditches. Trench consisted of ploughsoil with two alluvial layers. Not bottomed due to possible archaeological features						Length (m)	30
						Width (m)	1.8
						Avg. depth (m)	0.4
Context No.	Type	Fill Of	Width (m)	Depth (m)	Description	Finds	Date
45000	Layer			0.12	Ploughsoil. Friable dark greyish brown silty clay		
45001	Layer			0.16	Alluvial Layer. Firm light blueish grey silty clay.	Fe hook	undated

45002	Layer				Natural. Mid yellowish brown silty clay		
45003	Cut		0.92	0.28	Ditch. E-W		
45004	Fill	45003	0.92	0.28	Primary Fill. Firm light blueish yellowish brown clayey silt		
45005	Cut		1.3	0.18	Natural Feature. E-W		
45006	Layer		0.84	0.41	Alluvial Layer. Light grey blue mottled with light orange compact silty clay		
45007	Unexcavated feature		1.78		Ditch. Dark greyish brown clayey silt		
45008	Cut		3.26	1.06	Ditch		
45009	Fill	45008	3.26	1.06	Primary Fill. Mostly light or any brown with light blueish grey patches. Firm. Silty clay		
45010	Fill	45008	1.44	1.06	Primary Fill. Light blueish grey with patches of orange brown (oxidised). Firm. Silty clay.		
45011	Layer			0.13	Alluvial Layer. Firm mid reddish brown silty clay with grey mottling. Slightly Sandy		

Trench 451

General description					Orientation	NNE-SSW	
Trench consisted of ploughsoil and possible alluvial layer overlying natural geology.					Length (m)	30	
					Width (m)	1.8	
					Avg. depth (m)	0.46	
Context No.	Type	Fill Of	Width (m)	Depth (m)	Description	Finds	Date
45100	Layer			0.26	Ploughsoil. Dark grey clayey silt		
45101	Layer				Natural. Mid reddish brown sandy clay		
45102	Cut		1.08	0.56	Ditch. E-W running ditch, near V-shaped profile with narrow, flat base. No dating.		
45103	Fill	45102	1.08	0.56	Primary Fill. Mottled mid-grey/orange clay ditch fill, quite firm, no finds.		
45104	Layer			0.2	Alluvial Layer. Mottled dark grey/orange clayey silt layer running length of trench.		

45105	Cut		0.53	0.17	Ditch. Small ditch with moderately steep sides curving into concave base. Turns from a NW-SE heading to a roughly N-S one.		
45106	Fill	45105	0.53	0.17	Primary Fill. Mottled mid-light grey/light orange clayey silt, firm, no finds.		
Trench 452							
General description						Orientation	N-S
Trench consisted of ploughsoil overlying 2alluvial deposits. Not bottomed.						Length (m)	30
						Width (m)	1.8
						Avg. depth (m)	0.6
Context No.	Type	Fill Of	Width (m)	Depth (m)	Description	Finds	Date
45200	Layer			0.22	Ploughsoil. Friable dark greyish brown silty clay.		
45201	Layer			0.26	Alluvial Layer. Friable mid greyish brown clayey silt with common fe channels and rare charcoal		
45202	Cut		1.14	0.5	Ditch. Cut of ditch running NW-SE		
45203	Fill	45202		0.16	Secondary Fill. Fill of ditch		
45204	Fill	45202		0.34	Secondary Fill. Fill of ditch	Pottery Fired clay Fired clay	Late Preh
45205	Cut		0.32	0.35	Posthole. Sub-circular with steep/vertical sides. Cut by modern field drain so extent cannot be seen in plan.		
45206	Fill	45205	0.32	0.35	Secondary Fill. Friable mode grey brown silty clay. <5% small gravel and charcoal inclusions. Some dateable evidence recovered.	pottery	Late Preh
45207	Cut		0.42	0.27	Ditch		
45208	Fill	45207	0.42	0.27	Primary Fill. Mid brown grey compact sandy clay with rare medium sized fragmented stones	Pottery Fired clay	RB
45209	Cut		0.6	0.24	Ditch		

45210	Fill	45209	0.6	0.24	Primary Fill. Mid grey brown, mottled with red and black flecks, compact silty clay. Rare medium sized fragmented stones and charcoal	Pottery Fired clay	RB undated
45211	Cut				Natural Feature		
45212	Cut		1.11	0.07	Ditch		
45213	Fill	45212	1.11	0.07	Primary Fill. Mid blue grey mottled with brown red flecks, compact silty clay with rare charcoal and small subangular stone inclusions.	Fired clay	
45214	Cut		0.44	0.11	Ditch. ditch running NE-SW Truncated by land drain so unable to identify relationship to unexcavated ditch 45215		
45215	Unexcavated feature		0.74		Ditch. Unexcavated ditch running SE-NW. truncated by land drain so unable to excavate or identify relationship with unexcavated ditch 45214.		
45216	Fill	45214	0.44	0.11	Secondary Fill. Mid greyish brown silty clay		
45217	Layer			0.06	Alluvial Layer. Firm mid greyish brown silty clay		
Trench 453							
General description						Orientation	N-S
Trench devoid of archaeology. Consists of ploughsoil and subsoil overlying natural geology of silty clay.						Length (m)	30
						Width (m)	2
						Avg. depth (m)	0.38
Context No.	Type	Fill Of	Width (m)	Depth (m)	Description	Finds	Date
45300	Layer			0.31	Ploughsoil. Dark greyish brown clayey silt.		
45301	Layer			0.07	Subsoil. Light greyish brown silty clay.		
45302	Layer				Natural. Mid yellowish brown silty clay.		
45303	Cut		0.4	0.08	Natural Feature. Mottled yellowish grey and brown silty clay.		

Trench 454							
General description					Orientation	N-S	
Trench contained six probable postholes and one ditch. Consists of ploughsoil overlying sequence of weathered bedrocks before London Clay.					Length (m)	30	
					Width (m)	6	
					Avg. depth (m)	2	
Context No.	Type	Fill Of	Width (m)	Depth (m)	Description	Finds	Date
45400	Layer			0.35	Ploughsoil. Dark grey clayey silt		
45401	Layer			0.2	Natural. Dark reddish brown silty clay		
45402	Cut		0.44	0.3	Posthole		
45403	Fill	45402		0.3	Primary Fill. Mid grey and mid brown mottled compact clay.		
45404	Cut		0.43	0.18	Posthole		
45405	Fill	45404			Primary Fill	Pottery Fired clay	Late Preh
45406	Cut				Posthole		
45407	Fill	45406			Primary Fill. Mid grey compact clay, with mottled brown areas.		
45408	Cut		0.23	0.03	Posthole		
45409	Fill	45408			Primary Fill. Very dark brown compact clay.	Fired clay	
45410	Cut		0.38	0.02	Posthole		
45411	Fill	45410			Primary Fill		
45412	Cut		0.43	0.18	Posthole		
45413	Fill	45412			Primary Fill. Dark grey compact clay with mid brown mottled areas.	Pottery Flint	RB
45414	Layer			0.48	Natural. Firm mid greyish brown silty clay. Weathered bedrock		
45415	Layer			0.68	Natural. Stiff mid greyish brown silty clay with bluish grey veins. London Clay		
45416	Cut				Ditch		
45417	Fill	45416			Primary Fill. Mid grey compact clay with mid brown patches.		
Trench 455							
General description					Orientation	N-S	
Trench contained two ditches, a probable gully, one pit and a tree throw. Ploughsoil overlying clay natural.					Length (m)	30	
					Width (m)	6	
					Avg. depth (m)	2	

Context No.	Type	Fill Of	Width (m)	Depth (m)	Description	Finds	Date
45500	Layer			0.4	Ploughsoil. Dark grey-brown clayey silt ploughsoil.		
45501	Layer			0.5	Natural. Mid orangish brown weathered London Clay		
45502	Cut				Pit. Possible pit in section along baulk on north-eastern side of trench		
45503	Fill	45502			Secondary Fill. Mid greyish brown silty clay with mottled patches of orange		
45504	Cut		0.66	0.2	Ditch		
45505	Fill	45504	0.66	0.2	Primary Fill. Mid grey brown. Silty clay. Charcoal rich.		
45506	Cut		1.44	0.64	Ditch. Possible ditch running west to east in northern end of trench		
45507	Fill	45506		0.31	Secondary Fill. Mid greyish brown mottled silty clay		
45508	Fill	45506		0.1	Secondary Fill. Mid brownish orange silty clay		
45509	Fill	45506		0.23	Secondary Fill. Mid orangeish grey silty clay with charcoal veins.	Fired clay Flint Fe blade	Iron Age
45510	Fill	45511		0.21	Secondary Fill. Mid greyish brown with orange patches and rooting. Interface between (45500) and (45501)		
45511	Cut		0.39	0.42	Ditch. Ditch running east to west cut by [45506]		
45512	Fill	45511		0.21	Primary Fill. Light greyish brown silty clay		
45513	Cut				Tree Throw. Possible tree throw in south of trench		
45514	Fill	45513			Secondary Fill. Mid greyish brown silty clay	Pottery Fired clay	LBA/EIA? undated
45515	Layer			0.2	Subsoil. brownish grey mottled yellowish red clayey silt		
45516	Layer			0.9	Natural. Brown mottled white and		

					yellow silty clay. Bedrock. LONDON CLAY		
Trench 456							
General description					Orientation	WSW-ENE	
Trench consists of ploughsoil, thin Alluvium over bleached horizon overlying and natural of LONDON CLAY FORMATION.					Length (m)	30	
					Width (m)	6	
					Avg. depth (m)	0.6	
Context No.	Type	Fill Of	Width (m)	Depth (m)	Description	Finds	Date
45600	Layer			0.4	Topsoil. Dark grey clayey silt		
45601	Layer			0.1	Alluvial Layer. Light brownish grey mottled clayey silt		
45602	Layer			0.95	Natural. Mid yellowish brown silty clay		
45603	Layer			0.11	Other Layer. Light grey silt. BLEACHED HORIZON		
45604	Layer			0.45	Natural. Brownish grey mottled white silty clay. BEDROCK / LONDON CLAY FORMATION		
Trench 457							
General description					Orientation	NE-SW	
Trench has revealed two ditches. Consists of ploughsoil and subsoil overlying the natural geology.					Length (m)	30	
					Width (m)	1.8	
					Avg. depth (m)	0.35	
Context No.	Type	Fill Of	Width (m)	Depth (m)	Description	Finds	Date
45700	Layer			0.23	Ploughsoil. Dark grey brown, silty clay.		
45701	Layer			0.12	Subsoil. Mid orange brown, clay.		
45702	Layer				Natural. Light orange brown, silty clay.		
45703	Cut		0.61	0.54	Ditch		
45704	Fill	45703	0.61	0.54	Deliberate Backfill. Light orangeish grey silty clay firm	Flint	
45705	Cut		0.78	0.57	Ditch		
45706	Fill	45705	0.78	0.38	Deliberate Backfill. Light bluish grey silty clay firm	Flint	
45707	Fill	45705	0.6	0.14	Deliberate Backfill. Mid brownish orange silty clay firm		

Trench 458							
General description					Orientation	NW-SE	
Trench devoid of archaeology. Consisted of ploughsoil overlying the sandy clay natural geology.					Length (m)	30	
					Width (m)	1.8	
					Avg. depth (m)	0.48	
Context No.	Type	Fill Of	Width (m)	Depth (m)	Description	Finds	Date
45800	Layer			0.36	Ploughsoil. Dark brown, silty clay.		
45801	Layer			0.12	Subsoil. Mid brown, silty clay.		
45802	Layer				Natural. Mid orangey brown, sandy clay.		
Trench 459							
General description					Orientation	NE-SW	
Trench has revealed two ditches. Consists of ploughsoil and subsoil overlying clay natural					Length (m)	30	
					Width (m)	2	
					Avg. depth (m)	0.45	
Context No.	Type	Fill Of	Width (m)	Depth (m)	Description	Finds	Date
45900	Layer			0.36	Ploughsoil. Dark blackish brown silty clay		
45901	Layer				Natural. Light orangeish brown clay with streaks of manganese and occasional white patches of sand		
45902	Unexcavated feature		0.5		Ditch. Ditch running N-S, parallel to further ditch in trench		
45903	Unexcavated feature		0.6		Ditch. Ditch running parallel to unexcavated ditch 45902.		
Trench 460							
General description					Orientation	NW-SE	
Trench has revealed a ring ditch and two potential hearths. Consists of ploughsoil and subsoil overlying clay natural.					Length (m)	30	
					Width (m)	2	
					Avg. depth (m)	0.5	
Context No.	Type	Fill Of	Width (m)	Depth (m)	Description	Finds	Date
46000	Layer			0.35	Ploughsoil. Dark blackish brown silty clay		
46001	Layer				Natural. Mid reddish brown clay with some white patches of sand and white inclusions		
46002	Layer			0.15	Subsoil		

46003	Cut		1.65	0.26	Other Cut. Cut for potential hearth/pit. Evidence of burning in feature, clay at the base of feature in natural was burned.		
46004	Fill	46003		0.26	Other Fill. Only fill of a potential hearth-cut/fill.	Fired clay	
46005	Cut		>2.0	0.62	Pit		
46006	Cut		2.5	0.15	Natural Feature		
46007	Cut		c 1.3	c 0.5	Ditch		
46008	Fill	46007			Primary Fill. Mid grey blue compact silty clay.		
46009	Fill	46007			Secondary Fill. Dark grey brown compact silty clay with frequent charcoal inclusions. Evidence of burning.	Pottery Fired clay Flint	LBA/EIA?
46010	Fill	46005			Primary Fill. Light bluish grey with orange patches silty clay compact	pottery	LBA/EIA?
46011	Fill	46005			Deliberate Backfill. Mid greyish orange silty clay compact		
46012	Fill	46005			Deliberate Backfill. Light bluish grey silty clay compact		
46013	Cut		0.6	0.44	Ditch		
46014	Fill	46013	0.6	0.44	Primary Fill. Mid grey blue, silty clay, charcoal (1%) burned clay (5-10%)		
46015	Cut		0.87	0.52	Ditch		
46016	Fill	46015	0.32	0.1	Primary Fill. Mid grey blue, silty clay, 1%> sub angular stones		
46017	Fill	46015	0.87	0.5	Secondary Fill. Dark brown grey, silty clay, 5% charcoal, 15-20% burned clay	Pottery Fired clay Flint	LBA-EIA?
46018	Fill	46015	0.87	0.1	Tertiary Fill. Mid grey brown, silty clay, 1%> sub angular stones		
46019	Layer				Occupation Layer. Light yellow grey, silty clay, fired clay and gravel inclusions		
46020	Layer				Occupation Layer. Light grey-brown silty clay, compact	Fired clay	
46021	Cut				Ring Ditch. Ditch, same as [46007] and [46015].		

46022	Fill	46021			Secondary Fill. Mid grey-blue silty clay with yellow mottling, compact		
-------	------	-------	--	--	--	--	--

Trench 461							
General description					Orientation	NE-SW	
Trench has revealed three ditches. Consists of ploughsoil and subsoil overlying sandy clay with gravels.					Length (m)	30	
					Width (m)	2	
					Avg. depth (m)	0.46	
Context No.	Type	Fill Of	Width (m)	Depth (m)	Description	Finds	Date
46100	Layer			0.34	Ploughsoil. Dark blackish brown silty clay		
46101	Layer				Natural. Mid reddish brown sandy clay with white inclusions and gravels		
46102	Layer			0.12	Subsoil. Mid yellowish grey, clayey silt. Compacted texture. It could have an alluvial sedimentation originally.		
46103	Cut		0.62	0.44	Ditch. It's a ditch with linear plan in NW-SE direction. It seems to belong to the same field system as the ditches that we have found in the trenches 482, 466, 462, 459, 457 and 494. In my opinion they could be part of a Romano-British grid as a regular division of the landscape.		
46104	Fill		0.62	0.44	Deliberate Backfill. It's a mid greyish blue clayey silt, with some orangey flecks with sandy texture. It's a foundational fill used for a cultivation ditch. Very likely it belongs to a vineyard.		
46105	Unexcavated feature		0.55		Ditch. It's a ditch that runs in parallel and with the same direction (NW-SE) that [46103] does. Both of them seem to belong to the same field and therefore they're		

					contemporary, regarding also to their physical features (fill and shape in plan) they shall be part of the same grid.		
46106	Cut		0.66	0.48	Ditch		
46107	Fill	46106	0.66	0.48	Deliberate Backfill. Firm light greyish blue silty clay	Flint	

Trench 462

General description					Orientation	NE-SW
Trench has revealed two ditches. Consists of ploughsoil and subsoil overlying clay natural.					Length (m)	30
					Width (m)	2
					Avg. depth (m)	0.39

Context No.	Type	Fill Of	Width (m)	Depth (m)	Description	Finds	Date
46200	Layer			0.24	Ploughsoil. Dark blackish brown silty clay		
46201	Layer				Natural. Mid yellowish brown clay with orange patches		
46202	Unexcavated feature		0.6		Ditch. Ditch running N-S. Further ditch in trench is in parallel with this one.		
46203	Cut		0.85	0.59	Ditch		
46204	Fill	46203			Secondary Fill. Mid bluish grey, silty clay, charcoal present	pottery	MC1-EC2
46205	Layer			0.15	Subsoil. Light greyish brown, silty clay. It's overlying the both Romano-British ditches that have been found in this trench.		

Trench 463

General description					Orientation	NW-SE
Trench has revealed one ditch. Consists of ploughsoil and subsoil overlying the clayey natural.					Length (m)	30
					Width (m)	2
					Avg. depth (m)	0.4

Context No.	Type	Fill Of	Width (m)	Depth (m)	Description	Finds	Date
46300	Layer			0.25	Ploughsoil. Dark blackish brown silty clay		
46301	Layer			0.3	Natural. Head deposit. Mid yellowish brown clay with blue patches		
46302	Unexcavated feature				Ditch. Ditch seen in E facing section of trench. Appears to be		

					same as [46103] (46104). Photo numbers 3611 and 3612.		
46303	Layer			0.15	Subsoil. Light yellowish brown silty clay, compact. Occasional charcoal flecks		
46304	Layer				Natural. London clay (bedrock).		

Trench 464

General description						Orientation	NE-SW
Trench has revealed two ditches. Consists of ploughsoil overlying clay natural with white inclusions						Length (m)	30
						Width (m)	2
						Avg. depth (m)	0.4
Context No.	Type	Fill Of	Width (m)	Depth (m)	Description	Finds	Date
46400	Layer			0.22	Ploughsoil. Dark blackish brown silty clay		
46401	Layer				Natural. Mid yellowish brown clay with gravels and patches of sand		
46402	Cut		0.59	0.32	Ditch		
46403	Fill	46402	0.59	0.32	Deliberate Backfill. Mid blueish grey mixed with natural.		
46404	Layer			0.18	Subsoil. Mid grey brown clay. Inclusions of CBM		
46405	Unexcavated feature		0.5		Ditch. It's a linear ditch with NW-SE direction, running in parallel to [46402]. It belongs also to the Romano-British cultivation field system. Mid blueish grey fill. Silty clay composition.		

Trench 465

General description						Orientation	NE-SW
Trench devoid of archaeology. Consisted of ploughsoil and alluvial layer overlying the natural clay and gravels.						Length (m)	30
						Width (m)	1.8
						Avg. depth (m)	0.62
Context No.	Type	Fill Of	Width (m)	Depth (m)	Description	Finds	Date
46500	Layer			0.3	Ploughsoil. Dark brown, silty clay. Friable texture.		
46501	Layer			0.32	Natural. Head deposit. Mid greyish blue.		

					Compacted texture. It's compounded by clayey clay.		
46502	Layer				Natural. London clay (bedrock).		
Trench 466							
General description					Orientation	NW-SE	
Trench has revealed two ditches' terminus. Consisted of ploughsoil and subsoil overlying the natural geology.					Length (m)	30	
					Width (m)	1.8	
					Avg. depth (m)	0.54	
Context No.	Type	Fill Of	Width (m)	Depth (m)	Description	Finds	Date
46600	Layer			0.24	Ploughsoil. Dark brown silty clay. Friable texture.		
46601	Layer			0.46	Natural. Head deposit. Mid reddish brown. It has a friable texture. It's sandy clay with so many patches and streams' bed with pebbles and sub-rounded stone gravels as result of water activities. It has appeared also, at 0.70 m of depth, some patches of the "London clay" geology with the calcareous' white flecks.		
46602	Cut		0.53	0.47	Ditch. Terminus		
46603	Fill	46602			Secondary Fill. Light blueish grey silty clay, compact		RB
46604	Layer			0.3	Subsoil. Yellowish grey silty clay compact		
46605	Cut		0.75	0.4	Ditch. Terminus of a ditch.		
46606	Fill	46605	0.75	0.4	Deliberate Backfill. Foundational fill of the trench [46605].		
46607	Layer				Natural. London clay (bedrock).		
Trench 467							
General description					Orientation	NW-SE	
Trench devoid of archaeology. Consisted of ploughsoil overlying the clayey and gravelly geology.					Length (m)	30	
					Width (m)	1.8	
					Avg. depth (m)	0.3	
Context No.	Type	Fill Of	Width (m)	Depth (m)	Description	Finds	Date

46700	Layer			0.3	Ploughsoil. Dark brown, silty clay. Friable texture.		
46701	Layer			0.5	Natural. Head deposit. Mid orangey brown. Compacted texture. It's compounded by sandy clay and gravels. It has also some bluish grey patches (oxide of manganese). It seems to be the result of an alluvial sedimentation.		
46702	Layer				Natural. London clay (bedrock).		

Trench 468

General description					Orientation	NE-SW	
Trench devoid of archaeology. Consisted of ploughsoil overlying the clayey and gravelly geology.					Length (m)	30	
					Width (m)	1.8	
					Avg. depth (m)	0.35	
Context No.	Type	Fill Of	Width (m)	Depth (m)	Description	Finds	Date
46800	Layer			0.35	Ploughsoil. Dark brown, silty clay. Friable texture.		
46801	Layer			0.5	Natural. Head deposit. Mid reddish brown. Compacted texture. It's compounded by sandy clay and gravels. We've found also, at 0.85 m of depth, the "London clay" with the white flecks. It has also some patches of bluish grey silty clay (oxide of manganese).		
46802	Cut		0.89	0.35	Natural Feature. Seems to be a natural feature. It has a sub-circular shape in plan and it looks to be the result of a natural deposition of oxide of manganese made by the water activity.		
46803	Layer				Natural. London clay (bedrock).		

Trench 469

General description					Orientation	NW-SE
Trench devoid of archaeology. Consisted of ploughsoil and subsoil overlying the natural clay.					Length (m)	30
					Width (m)	1.8
					Avg. depth (m)	0.35

Context No.	Type	Fill Of	Width (m)	Depth (m)	Description	Finds	Date
46900	Layer			0.35	Ploughsoil. Dark brown silty clay. Friable texture.		
46901	Layer			0.3	Natural. Head deposit. Mid reddish brown, sandy clay. It has so many patches of bluish grey compounded by oxide of manganese as result of the water activities. Also the gravelly texture, with pebbles and sub-rounded stones, it's a obvious proof of the alluvial sedimentation of this geological layer.		
46902	Layer				Natural. London clay (bedrock).		

Trench 470

General description	Orientation	NE-SW
Trench devoid of archaeology. Consisted of the ploughsoil overlying the natural geology.	Length (m)	30
	Width (m)	1.8
	Avg. depth (m)	0.35

Context No.	Type	Fill Of	Width (m)	Depth (m)	Description	Finds	Date
47000	Layer			0.35	Ploughsoil. Dark brown, silty clay. Friable texture.		
47001	Layer			0.4	Natural. Head deposit. Mid orangey brown. Compacted texture. It' compounded by sand, gravels and sandy clayey as result of water activity. It contains also some patches of bluish grey patches of oxide of manganese and also some reddish yellow ones of oxide of iron.		
47002	Layer				Natural. London clay (bedrock). We've reached it in a slot dug by the machine at the south-western end of the trench.		

Trench 471

General description	Orientation	NW-SE
Trench devoid of archaeology. Consists of ploughsoil and subsoil overlying natural.	Length (m)	30
	Width (m)	2

							Avg. depth (m)	0.45
Context No.	Type	Fill Of	Width (m)	Depth (m)	Description	Finds	Date	
47100	Layer			0.3	Ploughsoil. Dark grey brown, silty clay.			
47101	Layer			0.15	Subsoil. Light orange brown, silty clay.			
47102	Layer				Natural. Mid orange brown with grey mottling, clay.			
Trench 472								
General description						Orientation	NE-SW	
Trench devoid of archaeology. Consisted of ploughsoil overlying the clayey and gravelly natural geology.						Length (m)	30	
						Width (m)	1.8	
						Avg. depth (m)	0.35	
Context No.	Type	Fill Of	Width (m)	Depth (m)	Description	Finds	Date	
47200	Layer			0.35	Ploughsoil. Dark brown, silty clay. Friable texture.			
47201	Layer			0.4	Natural. Head deposit. Mid reddish brown. Friable texture. It has a sandy gravel composition because is the result of so many water activities (basically streams' and creeks' beds with alluvial sedimentation). Is overlying the "London clay" (= bedrock).			
47202	Layer				Natural. London clay (bedrock).			
Trench 473								
General description						Orientation	NW-SE	
Trench devoid of archaeology. Consisted of ploughsoil overlying the natural geology.						Length (m)	30	
						Width (m)	1.8	
						Avg. depth (m)	0.35	
Context No.	Type	Fill Of	Width (m)	Depth (m)	Description	Finds	Date	
47300	Layer			0.35	Ploughsoil. Dark brown, silty clay. Friable texture.			
47301	Layer			0.4	Natural. Head deposit. Mid orangey brown. Compacted texture. It's compounded by sandy clay and gravels. It has also some patches of bluish grey silty clay (oxide of manganese).			

					It seems to be the result of an alluvial sedimentation. We've reached the "London clay" at 0.75 m of depth.		
47302	Layer				Natural. London clay (bedrock).		
Trench 474							
General description						Orientation	NE-SW
Trench devoid of archaeology. Consisted of ploughsoil overlying the natural geology.						Length (m)	30
						Width (m)	1.8
						Avg. depth (m)	0.38
Context No.	Type	Fill Of	Width (m)	Depth (m)	Description	Finds	Date
47400	Layer			0.38	Ploughsoil. Dark brown, silty clay. Friable texture.		
47401	Layer			0.4	Natural. Head deposit. Mid reddish brown. Compacted texture. It's compounded by sandy clay and rounded gravels as result of the water activity (alluvial sedimentation). It has also some patches of bluish grey sandy clay, as result of filtrations of water from the surface.		
47402	Layer				Natural. London clay (bedrock). We've reached it at 0.75 m of depth in a slot dug by the machine at the north-eastern end of the trench.		
Trench 475							
General description						Orientation	NW-SE
Trench devoid of archaeology. Consisted of ploughsoil overlying the natural geology.						Length (m)	30
						Width (m)	1.8
						Avg. depth (m)	0.35
Context No.	Type	Fill Of	Width (m)	Depth (m)	Description	Finds	Date
47500	Layer			0.35	Ploughsoil. Dark brown, silty clay.		
47501	Layer			0.25	Natural. Head deposit. Mid orangey brown. Compacted texture. It's compounded by sandy clay and gravels as result of water activity (alluvial)		

					sedimentation). It has some bluish grey patches of oxide of manganese.		
47502	Layer				Natural. London clay (bedrock). We've reached it in a slot dug in the south-eastern end by the machine.		
Trench 476							
General description						Orientation	E-W
Trench devoid of archaeology. Consisted of ploughsoil overlying the clayey natural geology.						Length (m)	30
						Width (m)	2
						Avg. depth (m)	0.5
Context No.	Type	Fill Of	Width (m)	Depth (m)	Description	Finds	Date
47600	Layer			0.2	Ploughsoil. Dark grey brown, silty clay.		
47601	Layer			0.3	Subsoil. Mid orange brown, silty sand.		
47602	Layer				Natural. Mid orange brown with grey mottling, clay.		

Trench 477							
General description						Orientation	NE-SW
Trench devoid of archaeology. At south-west end below topsoil, sequence of grey layers of weathered London clay down to 1.75 in NE part of trench. At south end yellowish brown London clay						Length (m)	30
						Width (m)	1.8
						Avg. depth (m)	0.35
Context No.	Type	Fill Of	Width (m)	Depth (m)	Description	Finds	Date
47700	Layer			0.35	Ploughsoil. Dark brown, silty clay. Friable texture.		
47701	Layer			0.2	Natural. Head deposit. Mid reddish brown. Compacted texture. It's compounded by sandy clay, gravels and clay. It has also some bluish grey patches of silty clay (oxide of manganese). Weathered bedrock, in south-west part of trench		
47702	Layer			0.26	Subsoil. Light grey brown, mottled clay silt,		
47703	Layer			0.31	Natural. Grey mottled reddish yellow, clay silt		
47704	Layer			0.45	Natural. Dark brown grey, clay silt		

47705	Layer			0.18	Natural. Dark grey mottled silty clay		
47706	Layer			0.2	Natural. Mid grey, silty clay		
47707	Layer			0.05	Natural. Mid grey frequently mottled yellowish red, silty clay, weakly structured, weathered bedrock		

Trench 478

General description					Orientation	NE-SW	
Trench devoid of archaeology. Consisted of ploughsoil overlying the gravelly sand natural geology.					Length (m)	30	
					Width (m)	1.8	
					Avg. depth (m)	0.3	
Context No.	Type	Fill Of	Width (m)	Depth (m)	Description	Finds	Date
47800	Layer			0.3	Ploughsoil. Dark brown, silty clay. Friable texture.		
47801	Layer				Natural. Mid orangey brown. Compacted texture. It's compounded by sandy clay, gravels and clay. It has also some bluish grey patches (oxide of manganese). It seems to be the result of an alluvial sedimentation.		

Trench 479

General description					Orientation	NW-SE	
Trench devoid of archaeology. Consisted of ploughsoil overlying the natural geology.					Length (m)	30	
					Width (m)	1.8	
					Avg. depth (m)	0.35	
Context No.	Type	Fill Of	Width (m)	Depth (m)	Description	Finds	Date
47900	Layer			0.35	Ploughsoil. Dark brown, silty clay. Friable texture.		
47901	Layer				Natural. Mid reddish brown. Compacted texture. It's compounded by sandy clay and gravels. It has also some patches of bluish grey sandy clay (oxide of manganese).		

Trench 480

General description					Orientation	NE-SW
Trench devoid of archaeology. Consisted of ploughsoil and subsoil overlying natural geology.					Length (m)	30
					Width (m)	1.8

						Avg. depth (m)	0.6
Context No.	Type	Fill Of	Width (m)	Depth (m)	Description	Finds	Date
48000	Layer			0.3	Ploughsoil. Dark grey brown, silty clay.		
48001	Layer			0.3	Subsoil. Mid orange brown, silty clay.		
48002	Layer				Natural. Mid orange brown with yellow mottling, silty gravel.		

Trench 481

General description						Orientation	NW-SE
Trench devoid of archaeology. Consisted of ploughsoil and subsoil overlying the natural geology.						Length (m)	30
						Width (m)	2
						Avg. depth (m)	0.45

Context No.	Type	Fill Of	Width (m)	Depth (m)	Description	Finds	Date
48100	Layer			0.3	Ploughsoil. Dark grey brown, silty clay.		
48101	Layer			0.15	Subsoil. Mid orange brown, silty clay.		
48102	Layer				Natural. Mid red brown, silty gravel.		

Trench 482

General description						Orientation	NE-SW
This trench has revealed 4 ditches running in parallel through the trench in NW-SE direction. Consisted of ploughsoil and subsoil overlying the gravelly sand natural geology.						Length (m)	30
						Width (m)	2
						Avg. depth (m)	0.49

Context No.	Type	Fill Of	Width (m)	Depth (m)	Description	Finds	Date
48200	Layer			0.3	Ploughsoil. Dark grey brown, silty clay.		
48201	Layer			0.19	Subsoil. Mid orange brown, silty clay.		
48202	Layer				Natural. Mid orangey brown with grey mottling, silty gravel and clay. There are also so many patches of "London clay".		
48203	Cut		0.5	0.54	Ditch		
48204	Fill	48203	0.5	0.54	Primary Fill. Light orange grey with darker orange mottling, silty clay.		
48205	Cut		0.5	0.48	Ditch. Terminus		
48206	Fill	48205	0.5	0.28	Secondary Fill. Light orangeish grey silty clay		
48207	Fill	48205	0.5	0.18	Secondary Fill. Light greyish orange silty clay, firm		
48208	Cut		0.58	0.54	Ditch		

48209	Fill	48208			Secondary Fill. Light orange-grey silty clay firm		
48210	Cut		1.7	0.52	Ditch		
48211	Fill	48210	1.7	0.52	Primary Fill. Dark greyish brown silty clay	Flint	

Trench 483

General description					Orientation	E-W
Trench devoid of archaeology. Consists of ploughsoil and subsoil overlying clay natural with gravel.					Length (m)	30
					Width (m)	2
					Avg. depth (m)	0.66

Context No.	Type	Fill Of	Width (m)	Depth (m)	Description	Finds	Date
48300	Layer			0.3	Ploughsoil. Dark blackish brown silty clay		
48301	Layer				Natural. Mid reddish brown clay with gravel		
48302	Layer			0.36	Subsoil		
48303	Cut		0.43	0.24	Natural Feature		

Trench 484

General description					Orientation	N-S
Trench devoid of archaeology. Consists of ploughsoil and subsoil overlying natural clay and gravel					Length (m)	30
					Width (m)	2
					Avg. depth (m)	0.4

Context No.	Type	Fill Of	Width (m)	Depth (m)	Description	Finds	Date
48400	Layer			0.3	Ploughsoil. Dark blackish brown silty clay		
48401	Layer			0.1	Subsoil. Mid yellowish brown clay with dark streaks		
48402	Layer				Natural. mid reddish brown clay with gravel		

Trench 485

General description					Orientation	E-W
Trench devoid of archaeology. Consists of ploughsoil overlying natural of clay and gravel					Length (m)	30
					Width (m)	2
					Avg. depth (m)	0.3

Context No.	Type	Fill Of	Width (m)	Depth (m)	Description	Finds	Date
48500	Layer			0.3	Ploughsoil. Dark blackish brown silty clay		
48501	Layer				Natural. Mid reddish brown clay with some gravel		

Trench 486

General description					Orientation	N-S
---------------------	--	--	--	--	-------------	-----

Trench devoid of archaeology. Consists of ploughsoil and subsoil overlying natural clay and gravel						Length (m)	30
						Width (m)	2
						Avg. depth (m)	0.45
Context No.	Type	Fill Of	Width (m)	Depth (m)	Description	Finds	Date
48600	Layer			0.3	Ploughsoil. Dark blackish brown silty clay		
48601	Layer			0.15	Subsoil. Mid yellowish brown clay with dark patches		
48602	Layer				Natural. Mid reddish brown clay with some gravel		
Trench 487							
General description						Orientation	E-W
Trench has revealed two ditches running in NNW-SSE direction, one seems to be a re-cut of the other and towards the east end and towards the west end another linear running N-S has been left unexcavated. Consists of ploughsoil and subsoil overlying natural of clay with gravels and sand						Length (m)	30
						Width (m)	2
						Avg. depth (m)	0.5
Context No.	Type	Fill Of	Width (m)	Depth (m)	Description	Finds	Date
48700	Layer			0.3	Ploughsoil. Dark blackish brown silty clay		
48701	Layer		0.2	0.2	Subsoil. Mid greyish brown silty clay		
48702	Layer				Natural. Dark reddish brown clay with gravel patches		
48703	Cut		1.23	0.29	Ditch		
48704	Fill	48703	1.23	0.29	Primary Fill. Light mottled greyish/yellowish brown silty clay	Pottery	RB
48705	Cut		0.36	0.26	Ditch		
48706	Fill	48705	0.36	0.26	Primary Fill. Mid greyish brown		
48707	Unexcavated feature		0.5		Ditch. Running N-S		
Trench 488							
General description						Orientation	N-S
Trench has revealed one ditch running in NW-SE direction. Consists of ploughsoil and subsoil overlying the natural clay and gravel.						Length (m)	30
						Width (m)	2
						Avg. depth (m)	0.5
Context No.	Type	Fill Of	Width (m)	Depth (m)	Description	Finds	Date
48800	Layer		2	0.25	Ploughsoil. Dark greyish brown silty clay		
48801	Layer		2	0.25	Subsoil. Mid greyish brown silty clay		
48802	Layer		2		Natural. Dark greyish brown clay and gravel patches		

48803	Cut		0.87	0.56	Ditch		
48804	Fill	48803	0.87	0.56	Primary Fill. Light Mottled yellowish/greyish brown silty clay		

Trench 489

General description						Orientation	N-S
Two ditches at south end of trench. Trench devoid of archaeology. Consists of ploughsoil and subsoil overlying the natural clay and gravel.						Length (m)	30
						Width (m)	2
						Avg. depth (m)	0.45
Context No.	Type	Fill Of	Width (m)	Depth (m)	Description	Finds	Date
48900	Layer		2	0.3	Ploughsoil. Dark greyish brown silty clay		
48901	Layer		2	0.15	Subsoil. Mid greyish brown silty clay		
48902	Layer		2		Natural. Dark greyish brown clay and gravel patches		
48903	Cut		0.72	0.3	Ditch		
48904	Fill	48903	0.46	0.3	Primary Fill. Compact, medium orange brown, silt clay, occasional charcoal flecks		
48905	Fill	48903	0.62	0.3	Secondary Fill. Compact, medium greyish black, silty clay, frequent charcoal flecks		
48906	Fill	48903	0.26	0.13	Tertiary Fill. Compact, medium greyish white, silt clay, moderate charcoal flecks.		
48907	Cut		0.43	0.18	Ditch		
48908	Fill	48907	0.43	0.18	Primary Fill. Compact, medium greyish brown, silt clay, occasional rounded stones		

Trench 490

General description						Orientation	E-W
Trench devoid of archaeology. Consisted of ploughsoil overlying the sandy clay natural geology.						Length (m)	30
						Width (m)	1.8
						Avg. depth (m)	0.3
Context No.	Type	Fill Of	Width (m)	Depth (m)	Description	Finds	Date
49000	Layer			0.3	Ploughsoil. Dark brown, silty clay. Friable texture.		
49001	Layer				Natural. Mid orangey brown. Compacted texture. It has gravelly patches and oxide of manganese and iron		

					ones as result of the water activity and filtrations from the raining water coming from the ground. There's not any remnant or remains of any kind of human activity.		
Trench 491							
General description						Orientation	NS
Trench devoid of archaeology. Consists of ploughsoil overlying natural clay with gravel						Length (m)	30
						Width (m)	2
						Avg. depth (m)	0.3
Context No.	Type	Fill Of	Width (m)	Depth (m)	Description	Finds	Date
49100	Layer			0.3	Ploughsoil. Dark blackish brown silty clay		
49101	Layer				Natural. Mid reddish brown clay with lots of gravel		
Trench 492							
General description						Orientation	E-W
Trench revealed a single linear running N-S through trench that seems to be a recut/extension of a earlier linear along the same alignment. Trench consists of ploughsoil and subsoil overlying the natural clay and gravel.						Length (m)	30
						Width (m)	2
						Avg. depth (m)	0.45
Context No.	Type	Fill Of	Width (m)	Depth (m)	Description	Finds	Date
49200	Layer		2	0.25	Ploughsoil. Dark greyish brown silty clay		
49201	Layer		2	0.2	Subsoil. Mid greyish brown silty clay		
49202	Layer		2		Natural. Dark greyish brown clay with gravel patches		
49203	Cut		0.9	0.28	Ditch. Re-cut/extension of earlier ditch [49205]		
49204	Fill	49203	0.9	0.28	Primary Fill. Light brownish grey silty clay		
49205	Cut		0.3	0.27	Ditch. Re-cut by [49203]		
Trench 493							
General description						Orientation	N-S
Trench revealed four linear features, all running NE-SW. One of which terminates within the trench. Two have been left unexcavated. Trench consists of ploughsoil and subsoil overlying the natural clay and gravel.						Length (m)	30
						Width (m)	2
						Avg. depth (m)	0.5
Context No.	Type	Fill Of	Width (m)	Depth (m)	Description	Finds	Date
49300	Layer		2	0.25	Ploughsoil. Dark greyish brown silty clay		

49301	Layer		2	0.25	Subsoil. Mid greyish brown silty clay		
49302	Layer		2		Natural. Dark greyish brown clay and gravel patches		
49303	Cut		0.55	0.15	Gully		
49304	Fill	49303	0.55	0.15	Primary Fill. Mid greyish brown silty clay compact		
49305	Cut		0.65	0.11	Ditch		
49306	Fill	49305			Primary Fill. Firm, Light greyish brown silty clay	Pottery	Late Preh
49307	Unexcavated feature				Ditch		
49308	Unexcavated feature				Ditch. Truncated in the middle.		

Trench 494

General description						Orientation	E-W
Trench revealed two linears running N-S through trench. One was left unexcavated. Trench consists of ploughsoil overlying the natural clay and gravel.						Length (m)	30
						Width (m)	2
						Avg. depth (m)	0.25
Context No.	Type	Fill Of	Width (m)	Depth (m)	Description	Finds	Date
49400	Layer		2	0.25	Ploughsoil. Dark greyish brown silty clay		
49401	Layer		2	0.25	Natural. Head deposit. Mid greyish brown silty clay		
49402	Layer		2		Natural. Bedrock (London clay). Dark greyish brown clay and gravel patches		
49403	Cut		0.78	0.5	Ditch		
49404	Fill	49403	0.52	0.16	Primary Fill. Compact, medium greyish blue, silt clay, occasional iron panning		
49405	Fill	49403	0.78	0.34	Secondary Fill. Moderately compact, medium greyish brown, silt clay, frequent redeposited natural	Pot	RB
49406	Unexcavated feature				Ditch and pit or ditch terminal?		
49407	Void						
49408	Void						

Trench 495

General description						Orientation	NW-SE
Trench devoid of archaeology. Consists of ploughsoil and subsoil overlying a colluvial Deposit in the trench centre over the natural clay. Natural Pleistocene Head Deposits over London Clay at trench end						Length (m)	30
						Width (m)	2
						Avg. depth (m)	0.3

Context No.	Type	Fill Of	Width (m)	Depth (m)	Description	Finds	Date
49500	Layer		2	0.3	Ploughsoil. Dark greyish brown silty clay		
49501	Layer			0.45	Colluvial Layer. Mid greyish brown clayey silt		
49502	Layer			0.13	Natural. Grey clayey silt, GLEYED HORIZON		
49503	Layer			0.13	Natural. Firm to stiff grey mottled strong brown clay. LONDON CLAY		
49504	Void						
49505	Void						
49506	Layer			0.39	Natural. Brownish yellow clayey silt with lenses of brown clayey gravel. HEAD DEPOSIT		

Trench 496

Context No.	Type	Fill Of	Width (m)	Depth (m)	Description	Finds	Date
General description						Orientation	N-S
Trench devoid of archaeology. Consists of ploughsoil and subsoil overlying the natural clay and gravel.						Length (m)	30
						Width (m)	2
						Avg. depth (m)	0.5
49600	Layer		2	0.3	Ploughsoil. Dark greyish brown silty clay		
49601	Layer		2	0.2	Subsoil. Mid greyish brown silty clay		
49602	Layer		2		Natural. Dark greyish brown clay and gravel patches		
49603	Void						

Trench 497

Context No.	Type	Fill Of	Width (m)	Depth (m)	Description	Finds	Date
General description						Orientation	E-W
Trench devoid of archaeology. Consists of ploughsoil and subsoil overlying the natural clay and gravel.						Length (m)	30
						Width (m)	2
						Avg. depth (m)	0.5
49700	Layer		2	0.25	Ploughsoil. Dark greyish brown silty clay		
49701	Layer		2	0.25	Subsoil. Mid greyish brown silty clay		
49702	Layer		2		Natural. Dark greyish brown clay and gravel patches		

Trench 498							
General description						Orientation	N-S
Trench devoid of archaeology. Consists of ploughsoil overlying the natural clay and gravel.						Length (m)	30
						Width (m)	2
						Avg. depth (m)	0.3
Context No.	Type	Fill Of	Width (m)	Depth (m)	Description	Finds	Date
49800	Layer		2	0.3	Ploughsoil. Dark greyish brown silty clay		
49801	Layer		2	0.15	Natural. Head deposit. Mid greyish brown silty clay		
49802	Layer		2		Natural. Bedrock (London clay). Dark greyish brown clay and gravel patches		
Trench 499							
General description						Orientation	E-W
Trench devoid of archaeology. Consists of ploughsoil overlying the natural clay and gravel.						Length (m)	30
						Width (m)	2
						Avg. depth (m)	0.2
Context No.	Type	Fill Of	Width (m)	Depth (m)	Description	Finds	Date
49900	Layer		2	0.2	Ploughsoil. Dark greyish brown silty clay		
49901	Layer		2	0.3	Natural. Head deposit. Mid greyish brown silty clay		
49902	Layer		2		Natural. Bedrock. Dark greyish brown clay and gravel patches		
Trench 500							
General description						Orientation	N-S
Trench devoid of archaeology. Consists of ploughsoil overlying the natural clay.						Length (m)	30
						Width (m)	2
						Avg. depth (m)	0.2
Context No.	Type	Fill Of	Width (m)	Depth (m)	Description	Finds	Date
50000	Layer		2	0.2	Ploughsoil. Dark greyish brown silty clay		
50001	Layer		2	0.3	Natural. Head deposit. Mid greyish brown silty clay		
50002	Layer		2		Natural. Bedrock (London clay). Dark greyish brown clay and gravel patches		

Trench 501							
General description						Orientation	E-W
Trench devoid of archaeology. Consists of ploughsoil and subsoil overlying natural geology of clay and gravel.						Length (m)	30
						Width (m)	2
						Avg. depth (m)	0.45
Context No.	Type	Fill Of	Width (m)	Depth (m)	Description	Finds	Date
50100	Layer		2	0.25	Ploughsoil. Dark greyish brown silty clay		
50101	Layer		2	0.2	Subsoil. Mid greyish brown silty clay		
50102	Layer		2		Natural. Dark greyish brown clay and gravel patches		
Trench 502							
General description						Orientation	N-S
Trench revealed a single linear running NE-SW through the middle of the trench. Trench consists of ploughsoil and subsoil overlying natural geology of clay and gravel.						Length (m)	30
						Width (m)	2
						Avg. depth (m)	0.6
Context No.	Type	Fill Of	Width (m)	Depth (m)	Description	Finds	Date
50200	Layer		2	0.3	Ploughsoil. Dark greyish brown silty clay		
50201	Layer		2	0.3	Subsoil. Mid greyish brown silty clay		
50202	Layer		2		Natural. Dark greyish brown clay and gravel patches		
50203	Cut		0.8	0.17	Ditch		
50204	Fill	50203	0.8	0.17	Primary Fill. Firm, Light greyish brown, silty clay		
Trench 503							
General description						Orientation	E-W
Trench devoid of archaeology. Consists of ploughsoil overlying natural geology of clay and gravel.						Length (m)	30
						Width (m)	2
						Avg. depth (m)	0.2
Context No.	Type	Fill Of	Width (m)	Depth (m)	Description	Finds	Date
50300	Layer		2	0.2	Ploughsoil. Dark greyish brown silty clay		
50301	Layer		2	0.2	Natural. Head deposit. Mid greyish brown silty clay		
50302	Layer		2		Natural. Bedrock. Dark greyish brown		

					clay and gravel patches		
Trench 504							
General description						Orientation	N-S
Trench devoid of archaeology. Consists of ploughsoil and subsoil overlying natural geology of clay and gravel.						Length (m)	0.3
						Width (m)	2
						Avg. depth (m)	0.4
Context No.	Type	Fill Of	Width (m)	Depth (m)	Description	Finds	Date
50400	Layer		2	0.2	Ploughsoil. Dark greyish brown silty clay		
50401	Layer		2	0.2	Subsoil. Mid greyish brown silty clay		
50402	Layer		2	0.25	Natural. Head deposit. Dark greyish brown clay with gravel patches		
50403	Layer				Natural. London clay (bedrock)		
Trench 505							
General description						Orientation	E-W
Trench revealed a single linear running N-S through the middle of the trench. Trench consists of ploughsoil and subsoil overlying natural geology of clay and gravel patches.						Length (m)	0.3
						Width (m)	2
						Avg. depth (m)	0.4
Context No.	Type	Fill Of	Width (m)	Depth (m)	Description	Finds	Date
50500	Layer		2	0.2	Ploughsoil. Dark greyish brown silty clay		
50501	Layer		2	0.2	Subsoil. Mid greyish brown silty clay		
50502	Layer		2	0.4	Natural. Head deposit. Dark greyish brown clay and gravel patches.		
50503	Cut		1.15	0.4	Ditch		
50504	Fill	50503	1.15	0.4	Primary Fill. Light brownish grey silty clay		
50505	Layer				Natural. London clay (bedrock). We've reached it in a slot dug at the eastern end of the trench by the machine.		
Trench 506							
General description						Orientation	NE- SW
Trench devoid of archaeology. Consists of ploughsoil and subsoil overlying the natural clay.						Length (m)	30
						Width (m)	1.8

						Avg. depth (m)	0.5
Context No.	Type	Fill Of	Width (m)	Depth (m)	Description	Finds	Date
50600	Layer			0.31	Ploughsoil. Mid greyish brown. Silty clay.		
50601	Layer			0.19	Subsoil. Mid yellowish brown. Silty clay.		
50602	Layer				Natural. Mid orange brown. Clayey clay.		
Trench 507							
General description						Orientation	NE-SW
Trench devoid of archaeology. Consists of ploughsoil and subsoil overlying clay natural. One potential pit but after testing it was identified as rooting.						Length (m)	30
						Width (m)	1.8
						Avg. depth (m)	0.6
Context No.	Type	Fill Of	Width (m)	Depth (m)	Description	Finds	Date
50700	Layer			0.34	Ploughsoil. Dark grey brown. silty clay		
50701	Layer			0.26	Subsoil. Dark yellow brown. Silty clay.		
50702	Layer				Natural. Mid orange brown. Clayey clay. Yellow inclusions with gravel inclusions.		
Trench 508							
General description						Orientation	NW-SE
Trench devoid of archaeology. Consists of ploughsoil and subsoil overlying the natural clay.						Length (m)	30
						Width (m)	1.8
						Avg. depth (m)	0.5
Context No.	Type	Fill Of	Width (m)	Depth (m)	Description	Finds	Date
50800	Layer			0.3	Ploughsoil. Dark greyish brown. Silty clay.		
50801	Layer			0.2	Subsoil. Mid yellowish brown. Silty clay		
50802	Layer				Natural. Mid orange brown. Clayey clay		
Trench 509							
General description						Orientation	NE-SW
Trench devoid of archaeology. Consists of ploughsoil and subsoil overlying the natural clay.						Length (m)	30
						Width (m)	1.8
						Avg. depth (m)	0.6
Context No.	Type	Fill Of	Width (m)	Depth (m)	Description	Finds	Date
50900	Layer			0.34	Ploughsoil. Dark grey brown. Silty clay.		
50901	Layer			0.16	Subsoil. Mid yellowish brown. Silty clay		

50902	Layer				Natural. Mid orange brown. Clayey clay.		
Trench 510							
General description					Orientation	NW-SE	
Trench devoid of archaeology. Consists of ploughsoil and subsoil overlying the natural clay.					Length (m)	30	
					Width (m)	1.8	
					Avg. depth (m)	0.5	
Context No.	Type	Fill Of	Width (m)	Depth (m)	Description	Finds	Date
51000	Layer			0.3	Ploughsoil. Dark greyish brown. Silty clay.		
51001	Layer			0.2	Subsoil. Mid yellowish brown. Silty clay		
51002	Layer				Natural. Mid orange brown. Clayey clay.		
Trench 511							
General description					Orientation	NE-SW	
Trench devoid of archaeology. Consists of ploughsoil and subsoil overlying the natural clay.					Length (m)	30	
					Width (m)	1.8	
					Avg. depth (m)	0.5	
Context No.	Type	Fill Of	Width (m)	Depth (m)	Description	Finds	Date
51100	Layer			0.31	Ploughsoil. Dark greyish brown. Silty clay.		
51101	Layer			0.19	Subsoil. Mid yellowish brown. Silty clay.		
51102	Layer				Natural. Mid orange brown. Clayey clay.		
Trench 512							
General description					Orientation	NW-SE	
Trench devoid of archaeology. Consists of ploughsoil and subsoil overlying the natural clay.					Length (m)	30	
					Width (m)	1.8	
					Avg. depth (m)	0.4	
Context No.	Type	Fill Of	Width (m)	Depth (m)	Description	Finds	Date
51200	Layer			0.21	Ploughsoil. Mid greyish brown. Silty clay.		
51201	Layer			0.19	Subsoil. Mid yellowish brown. Silty clay.		
51202	Layer				Natural. Mid orange brown. Clayey clay		
Trench 513							
General description					Orientation	NW-SE	
Trench devoid of archaeology. Consists of ploughsoil and subsoil overlying the natural geology clay.					Length (m)	30	
					Width (m)	1.8	

						Avg. depth (m)	0.4
Context No.	Type	Fill Of	Width (m)	Depth (m)	Description	Finds	Date
51300	Layer			0.15	Ploughsoil. Dark brown silty clay. Friable texture, the thick fraction (10%) contains gravels (1mm-1cm), sub-rounded limestones (1cm-5cm) and some flint nodules (1cm-5cm).		
51301	Layer			0.1	Subsoil. Mid brown clayey silt. Compacted texture, the thick fraction (5%) contains gravels (1mm-1cm), sub-rounded limestones (1cm-5cm) and some flint nodules (1cm-5cm).		
51302	Layer				Natural. Mid brown clayey clay with some patches of yellowish orange sandy sand geology. Compacted texture, the thick fraction (15%) contains rounded gravels (1mm-1cm), sub-rounded limestones (1cm-5cm), some flint nodules (1cm-5cm) and pebbles (1cm-5cm).		
Trench 514							
General description						Orientation	ENE-SWS
Trench with archaeology. Three ditches have been found running parallel in NW-SE direction and close to the NE ending of the trench.						Length (m)	30
						Width (m)	1.8
						Avg. depth (m)	0.55
Context No.	Type	Fill Of	Width (m)	Depth (m)	Description	Finds	Date
51400	Layer			0.35	Ploughsoil. Mid brownish grey, silty clay		
51401	Layer			0.1	Subsoil. Mid greyish brown, silty clay		
51402	Layer				Natural. Mid orange brown, silty clay		
51403	Cut		0.83	0.22	Ditch		
51404	Fill		0.83	0.22	Secondary Fill	CBM	

Trench 515							
General description					Orientation	NNW-SSE	
Trench devoid of archaeology. Consists of ploughsoil and subsoil overlying the natural clay.					Length (m)	30	
					Width (m)	1.8	
					Avg. depth (m)	0.52	
Context No.	Type	Fill Of	Width (m)	Depth (m)	Description	Finds	Date
51500	Layer			0.2	Ploughsoil. Dark brown silty clay. Friable texture, the thick fraction (10%) contains gravels (1mm-1cm), sub-rounded limestones (1cm-5cm) and some flint nodules (1cm-5cm).		
51501	Layer			0.1	Subsoil. Light brown clayey silt. Compacted texture, the thick fraction (5%) contains gravels (1mm-1cm), sub-rounded limestones (1cm-5cm) and some flint nodules (1cm-5cm).		
51502	Layer				Natural. Mid brown clayey clay with some patches of yellowish orange sandy sand geology. Compacted texture, the thick fraction (15%) contains rounded gravels (1mm-1cm), sub-rounded limestones (1cm-5cm), some flint nodules (1cm-5cm) and pebbles (1cm-5cm).		

Trench 516							
General description					Orientation	NE-SW (nearly E-W)	
It looks that in the mid of the trench could have a sub-circular shaped hearth or tree throw running beyond the northern baulk.					Length (m)	30	
					Width (m)	1.8	
					Avg. depth (m)	0.45	
Context No.	Type	Fill Of	Width (m)	Depth (m)	Description	Finds	Date
51600	Layer			0.2	Ploughsoil. Dark brown silty clay. Friable texture, the thick fraction (10%) contains gravels		

					(1mm-1cm), sub-rounded limestones (1cm-5cm) and some flint nodules (1cm-5cm).		
51601	Layer			0.1	Subsoil. Light brown clayey silt. Compacted texture, the thick fraction (5%) contains gravels (1mm-1cm), sub-rounded limestones (1cm-5cm) and some flint nodules (1cm-5cm).		
51602	Layer				Natural. Mid brown clayey clay with some patches of yellowish orange sandy sand geology. Compacted texture, the thick fraction (15%) contains rounded gravels (1mm-1cm), sub-rounded limestones (1cm-5cm), some flint nodules (1cm-5cm) and pebbles (1cm-5cm).		
51603	Cut		1.75	0.75	Possible hearth / tree throw		
51604	Fill	51603	1	0.08	Other Fill. Mid red-brown silty clay, less than 10% charcoal inclusions		
51605	Fill	51603	0.4	0.09	Other Fill. Dark brown grey silty clay, over 40% charcoal inclusions		
51606	Fill	51603	1	0.16	Other Fill. Mid brown grey silty clay, no inclusions		
51607	Fill		2.7	0.26	Other Fill. Mid orange brown silty clay, less than 5% sub angular stone inclusions		
Trench 517							
General description						Orientation	NW-SE
Trench devoid of archaeology. Consists of ploughsoil and subsoil overlying the natural clay.						Length (m)	30
						Width (m)	1.8
						Avg. depth (m)	0.4
Context No.	Type	Fill Of	Width (m)	Depth (m)	Description	Finds	Date
51700	Layer			0.3	Ploughsoil. Mid greyish brown. Silty clay.		

51701	Layer			0.1	Subsoil. Mid yellowish brown. Silty clay.		
51702	Layer				Natural. Mid orange brown. Clayey clay.		
Trench 518							
General description					Orientation	NW-SE	
Trench devoid of archaeology. Consists of ploughsoil and subsoil overlying the natural clay.					Length (m)	30	
					Width (m)	1.8	
					Avg. depth (m)	0.4	
Context No.	Type	Fill Of	Width (m)	Depth (m)	Description	Finds	Date
51800	Layer			0.2	Ploughsoil. Mid greyish brown. Silty clay.		
51801	Layer			0.2	Subsoil. Mid yellowish brown. Silty clay		
51802	Layer				Natural. Mid orange brown. Clayey clay		

Trench 519							
General description					Orientation	NE-SW	
Trench consists of ploughsoil and subsoil overlying the natural clay. One linear discovered, a 19th century boundary ditch seen also in the trenches 521, 523, 525 and 526.					Length (m)	30	
					Width (m)	1.8	
					Avg. depth (m)	0.5	
Context No.	Type	Fill Of	Width (m)	Depth (m)	Description	Finds	Date
51900	Layer			0.3	Ploughsoil. Mid greyish brown. Silty clay.		
51901	Layer			0.2	Subsoil. Mid yellowish brown. Silty clay.		
51902	Layer				Natural. Mid orange brown. Clayey clay		
51903	Unexcavated feature		1.95		Ditch. It's a linear ditch with NE-SW direction (nearly E-W). It belongs to a late 19th and early 20th century boundary of a field, at it appears on a map with this dating, but, obviously, it must be earlier than this, therefore is giving us just a "terminus antequem" dating. It has been found also at the trenches 521, 523, 525 and 526 (there it has been dug).		

51904	Cut				Ditch. Ditch running in NE-SW direction		
51905	Fill	51904			Primary Fill. Mid yellowish grey. Silty clay.	pottery	LBA/EIA?
Trench 520							
General description						Orientation	NE-SW
Seems to have a ditch in NW-SE direction. It runs beyond the NE ending and it has its terminus at the middle of the trench.						Length (m)	30
						Width (m)	1.8
						Avg. depth (m)	0.55
Context No.	Type	Fill Of	Width (m)	Depth (m)	Description	Finds	Date
52000	Layer			0.2	Ploughsoil. Dark brown silty clay. Friable texture, the thick fraction (10%) contains gravels (1mm-1cm), sub-rounded limestones (1cm-5cm) and some flint nodules (1cm-5cm).		
52001	Layer			0.15	Subsoil. Mid greyish brown clayey clay with some patches of yellowish orange sandy sand geology. Compacted texture, the thick fraction (15%) contains rounded gravels (1mm-1cm), sub-rounded limestones (1cm-5cm), some flint nodules (1cm-5cm) and pebbles (1cm-5cm).		
52002	Layer				Natural. Mid brown clayey clay with some patches of yellowish orange sandy sand geology. Compacted texture, the thick fraction (15%) contains rounded gravels (1mm-1cm), sub-rounded limestones (1cm-5cm), some flint nodules (1cm-5cm) and pebbles (1cm-5cm).		
52003	Cut			0.12	Ditch. Terminus of shallow linear. Same as [52103]		
52004	Fill	52003			Secondary Fill. Mid greyish brown with		

					orange mottling, silty clay, compact		
Trench 521							
General description					Orientation	N-S	
Trench consists of ploughsoil overlying natural geology of sandy clay.					Length (m)	30	
					Width (m)	2	
					Avg. depth (m)	0.3	
Context No.	Type	Fill Of	Width (m)	Depth (m)	Description	Finds	Date
52100	Layer			0.3	Ploughsoil. Dark brownish grey, silty clay.		
52101	Layer				Natural. Mid orangey brown, sandy clay.		
52102	Unexcavated feature		1.85		Ditch. It's a linear ditch with NE-SW direction (nearly E-W). It belongs to a late 19th and early 20th century boundary of a field, at it appears on a map with this dating, but, obviously, it must be earlier than this, therefore is giving us just a "terminus antequem" dating. It has been found also at the trenches 519, 523, 525 and 526 (there it has been dug).		
52103	Cut		0.52	0.21	Ditch. It's a ditch with linear plan running in NE-SW direction (nearly E-W). It appears also in the trench 520. We've some bits of Ancient Age pots in its fill (52104)		
52104	Fill	52103	0.5	0.21	Deliberate Backfill. It's the foundational fill (primary fill) of the ditch [52103]. We've found some bits of Ancient pots in this fill.	pottery	LBA/EIA?
52105	Cut		0.72	0.3	Ditch. Seems to be, in my opinion, a late Iron Age or pre-Roman ditch associated with some kind of field system. Regarding to the sherds of pots that we've found in the fill (52106), very rough		

					productions, we should consider this feature as a pre-Roman one (for further more information see (52106)).		
52106	Fill	52105	0.72	0.3	Secondary Fill. Mid greyish brown, silty clay with some reddish flecks of mineral iron. We've found some sherds of pot in it. It seems to be a quite rough production very likely pre-Roman stuff.		Late Preh
Trench 522							
General description						Orientation	E-W
Trench devoid of archaeology. Consists of ploughsoil and subsoil overlying natural geology of sandy clay.						Length (m)	30
						Width (m)	2
						Avg. depth (m)	0.4
Context No.	Type	Fill Of	Width (m)	Depth (m)	Description	Finds	Date
52200	Layer			0.25	Ploughsoil. Dark brownish grey, silty clay.		
52201	Layer			0.15	Subsoil. Mid greyish brown, silty clay.		
52202	Layer				Natural. Mid orangey brown, sandy clay.		
Trench 523							
General description						Orientation	NW-SE
Trench consists of ploughsoil and subsoil overlying the natural clay. One potential linear.						Length (m)	30
						Width (m)	1.8
						Avg. depth (m)	
Context No.	Type	Fill Of	Width (m)	Depth (m)	Description	Finds	Date
52300	Layer			0.4	Ploughsoil. Dark brownish black. Silty clay		
52301	Layer			0.1	Subsoil. Mid yellowish brown. Silty clay		
52302	Layer				Natural. Mid orange brown. Clayey clay		
52303	Unexcavated feature		1.95		Modern. It's a linear ditch in NE-SW direction that belongs to the late 19th or early 20th century boundary that we've also found at the		

					trenches 519, 521, 525 and 526.		
Trench 524							
General description					Orientation	NE-SW	
Trench devoid of archaeology. consists of ploughsoil and subsoil overlying the natural clay.					Length (m)	30	
					Width (m)	1.8	
					Avg. depth (m)	0.5	
Context No.	Type	Fill Of	Width (m)	Depth (m)	Description	Finds	Date
52400	Layer			0.2	Ploughsoil. Dark grey brown. Silty clay		
52401	Layer			0.2	Subsoil. Mid yellowish brown. Silty clay.		
52402	Layer				Natural. Mid orange brown. Clayey clay		
Trench 525							
General description					Orientation	NE-SW	
Trench consists of ploughsoil and subsoil overlying the natural clay. One potential linear.					Length (m)	30	
					Width (m)	1.8	
					Avg. depth (m)	0.4	
Context No.	Type	Fill Of	Width (m)	Depth (m)	Description	Finds	Date
52500	Layer			0.24	Ploughsoil. Dark greyish black. Silty clay		
52501	Layer			0.16	Subsoil. Mid yellowish brown. Silty clay		
52502	Layer				Natural. Mid orange brown. Clayey clay.		
52503	Unexcavated feature		1.75		Ditch. It's a linear ditch with NE-SW direction (nearly E-W). It belongs to a late 19th and early 20th century boundary of a field, at it appears on a map with this dating, but, obviously, it must be earlier than this, therefore is giving us just a "terminus antequem" dating. It has been found also at the trenches 521, 523, 519 and 526 (there it has been dug).		
Trench 526							
General description					Orientation	N-S	
					Length (m)	36	

Trench contains one large ditch in its centre and a late 19th and early 20th century boundary towards the southern end. Trench consists of ploughsoil overlying natural geology of sandy clay.						Width (m)	2
						Avg. depth (m)	0.3
Context No.	Type	Fill Of	Width (m)	Depth (m)	Description	Finds	Date
52600	Layer			0.3	Ploughsoil. Dark brownish grey, silty clay.		
52601	Layer				Natural. Mid orangey brown, sandy clay.		
52602	Cut		2.5	0.68	Ditch		
52603	Fill	52602	2.5	0.68	Deliberate Backfill	Pottery CBM	LBA/EIA? Post- med/mod

Trench 527

General description						Orientation	NW-SE
Trench revealed two tiny pits filled by charcoal that they need to be checked. Consisted of ploughsoil and subsoil overlying the natural geology clay.						Length (m)	30
						Width (m)	1.8
						Avg. depth (m)	0.45

Context No.	Type	Fill Of	Width (m)	Depth (m)	Description	Finds	Date
52700	Layer			0.12	Ploughsoil. Dark greyish brown, silty clay. The thick fraction of it (25%) has some gravels (1mm-1cm), some medium size sub-rounded limestones (1cm-5cm), some pebbles (1cm-6cm) and some large stones (bigger than 8cm).		
52701	Layer			0.22	Subsoil. Mid yellowish brown, silty clay. The thick fraction of the layer (25%) contains some sub-rounded gravels (1mm-1cm), some medium size limestones (1cm-5cm), some flint nodules (2cm-6cm) and a few chalk rocks (1cm-5cm).		
52702	Layer				Natural. Mid orangey brown, clayey clay. The thick fraction of the layer (15%) contains some gravels (1mm-1cm), some sub-rounded limestones (1cm-5cm), some flint nodules (2 cm-5cm)		

					and some chalk stones (1cm-5cm).		
52703	Cut		0.26	0.11	Natural Feature. Irregular shape in plan, undercutting edges. Most likely natural feature		
52704	Fill	52703	0.26	0.11	Other Fill. Dark blackish brown silty clay, friable. Charcoal 5-10%. Probable rooting filling natural feature		

Trench 528

General description						Orientation	E-W
Trench contains two ditches in its centre and an unidentified feature towards the western end. Consists of ploughsoil and subsoil overlying natural geology of clay.						Length (m)	30
						Width (m)	2
						Avg. depth (m)	0.45
Context No.	Type	Fill Of	Width (m)	Depth (m)	Description	Finds	Date
52800	Layer			0.3	Ploughsoil. Dark brownish grey, silty clay.		
52801	Layer			0.15	Subsoil. Mid-greyish brown, silty clay.		
52802	Layer				Natural. Mid orangey brown clay.		
52803	Cut		0.97	0.2	Ditch		
52804	Fill	52803	0.97	0.2	Secondary Fill. Mid greyish brown, silty clay with <1% sun angular stone inclusions		

Trench 529

General description						Orientation	N-S
Trench devoid of archaeology. Consists of ploughsoil overlying natural geology of clay.						Length (m)	30
						Width (m)	2
						Avg. depth (m)	0.3
Context No.	Type	Fill Of	Width (m)	Depth (m)	Description	Finds	Date
52900	Layer			0.3	Ploughsoil. Dark brownish grey, silty clay.		
52901	Layer				Natural. Dark greyish brown clay.		

Trench 530

General description						Orientation	E-W
Trench devoid of archaeology. Consists of ploughsoil overlying natural geology of clay.						Length (m)	30
						Width (m)	2
						Avg. depth (m)	0.6

Context No.	Type	Fill Of	Width (m)	Depth (m)	Description	Finds	Date
53000	Layer			0.25	Ploughsoil. Dark brownish grey, silty clay.		
53001	Layer				Natural. Dark reddish brown, silty clay.		
Trench 531							
General description						Orientation	E-W
Trench devoid of archaeology. Consists of ploughsoil overlying natural geology of clay.						Length (m)	30
						Width (m)	2
						Avg. depth (m)	0.25
Context No.	Type	Fill Of	Width (m)	Depth (m)	Description	Finds	Date
53100	Layer			0.32	Ploughsoil. Dark greyish brown clayey silt		
53101	Layer			0.1	Alluvial Layer. Mid to light yellowish brown silty clay		
53102	Layer			0.09	Buried soil. Very dark greyish brown to black humic clayey silt. Stabilisation horizon		
53103	Layer			0.21	Other Layer. Compact pale whiteish grey silt. Possible marl-like deposit		
53104	Layer			0.1	Natural. Compact, light yellowish brown clayey silt. Head deposit		
53105	Layer			0.16	Natural. Compact mid reddish to yellowish brown clayey silt with frequent blueish grey patches. Head deposit		
53106	Layer			0.4	Natural. Firm light yellowish brown silty clay. Weathered London Clay		
53107	Layer				Natural. Firm mid reddish to purpleish brown silty clay. London Clay		
Trench 532							
General description						Orientation	N-S
Trench devoid of archaeology. Consists of ploughsoil overlying natural geology of clay.						Length (m)	30
						Width (m)	2
						Avg. depth (m)	0.3

Context No.	Type	Fill Of	Width (m)	Depth (m)	Description	Finds	Date
53200	Layer			0.3	Ploughsoil. Dark brownish grey, silty clay.		
53201	Layer				Natural. Dark reddish brown clay.		

Trench 533

General description	Orientation	NE-SW
Trench devoid of archaeology. Consists of ploughsoil and subsoil overlying the natural clay.	Length (m)	30
	Width (m)	1.8
	Avg. depth (m)	0.45

Context No.	Type	Fill Of	Width (m)	Depth (m)	Description	Finds	Date
53300	Layer			0.15	Ploughsoil. Dark brown silty clay. Friable texture, the thick fraction (10%) contains gravels (1mm-1cm), sub-rounded limestones (1cm-5cm) and some flint nodules (1cm-5cm).		
53301	Layer			0.12	Subsoil. Light brown clayey silt. Compacted texture, the thick fraction (5%) contains gravels (1mm-1cm), sub-rounded limestones (1cm-5cm) and some flint nodules (1cm-5cm).		
53302	Layer				Natural. Mid brown clayey clay with some patches of yellowish orange sandy sand geology. Compacted texture, the thick fraction (15%) contains rounded gravels (1mm-1cm), sub-rounded limestones (1cm-5cm), some flint nodules (1cm-5cm) and pebbles (1cm-5cm).		

Trench 534

General description	Orientation	NE-SW
	Length (m)	30

Trench revealed two small pits or postholes that were very shallow, with no dateable evidence. Consists of ploughsoil and subsoil overlying the natural clay.					Width (m)	1.8	
					Avg. depth (m)	0.5	
Context No.	Type	Fill Of	Width (m)	Depth (m)	Description	Finds	Date
53400	Layer			0.12	Ploughsoil. Dark brown silty clay. Friable texture, the thick fraction (10%) contains gravels (1mm-1cm), sub-rounded limestones (1cm-5cm) and some flint nodules (1cm-5cm).		
53401	Layer			0.1	Subsoil. Light brown clayey silt. Compacted texture, the thick fraction (5%) contains gravels (1mm-1cm), sub-rounded limestones (1cm-5cm) and some flint nodules (1cm-5cm).		
53402	Layer				Natural. Mid brown clayey clay with some patches of yellowish orange sandy sand geology. Compacted texture, the thick fraction (15%) contains rounded gravels (1mm-1cm), sub-rounded limestones (1cm-5cm), some flint nodules (1cm-5cm) and pebbles (1cm-5cm).		
53403	Cut		0.24	0.04	Pit or posthole. Sub circular, very shallow, concave pit.		
53404	Fill	53403	0.24	0.04	Secondary Fill. Friable mid grey brown silty clay. <5% small gravel inclusions. No dateable evidence recovered.		
53405	Cut		0.26	0.06	Pit or posthole. Very shallow, gently sloping sides, concave base.		
53406	Fill	53405	0.26	0.06	Secondary Fill. Friable mid grey brown silty clay. <5% small gravel inclusions. No		

					dateable evidence recovered.		
Trench 535							
General description					Orientation	NE-SW	
Trench devoid of archaeology Consists of ploughsoil and subsoil overlying the natural clay.					Length (m)	30	
					Width (m)	1.8	
					Avg. depth (m)	0.5	
Context No.	Type	Fill Of	Width (m)	Depth (m)	Description	Finds	Date
53500	Layer			0.2	Ploughsoil. Mid greyish brown. Silty clay		
53501	Layer			0.3	Subsoil. Mid yellowish brown. Silty clay		
53502	Layer				Natural. Mid orange brown. Silty clay		
Trench 536							
General description					Orientation	NE-SW	
Trench devoid of archaeology. Consists of ploughsoil and subsoil overlying the natural clay					Length (m)	30	
					Width (m)	1.8	
					Avg. depth (m)	0.5	
Context No.	Type	Fill Of	Width (m)	Depth (m)	Description	Finds	Date
53600	Layer			0.1	Ploughsoil. Dark brown silty clay. Friable texture, the thick fraction (10%) contains gravels (1mm-1cm), sub-rounded limestones (1cm-5cm) and some flint nodules (1cm-5cm).		
53601	Layer			0.08	Subsoil. Light brown clayey silt. Compacted texture, the thick fraction (5%) contains gravels (1mm-1cm), sub-rounded limestones (1cm-5cm) and some flint nodules (1cm-5cm).		
53602	Layer				Natural. Mid brown clayey clay with some patches of white bits of chalk. Compacted texture, the thick fraction (15%) contains rounded gravels (1mm-1cm), sub-rounded limestones		

					(1cm-5cm), some flint nodules (1cm-5cm) and pebbles (1cm-5cm).		
Trench 537							
General description					Orientation	NW-SE	
Trench devoid of archaeology. Consists of ploughsoil and subsoil overlying the natural clay					Length (m)	30	
					Width (m)	1.8	
					Avg. depth (m)	0.48	
Context No.	Type	Fill Of	Width (m)	Depth (m)	Description	Finds	Date
53700	Layer			0.1	Ploughsoil. Dark brown silty clay. Friable texture, the thick fraction (10%) contains gravels (1mm-1cm), sub-rounded limestones (1cm-5cm) and some flint nodules (1cm-5cm).		
53701	Layer			0.12	Subsoil. Light brown clayey silt. Compacted texture, the thick fraction (5%) contains gravels (1mm-1cm), sub-rounded limestones (1cm-5cm) and some flint nodules (1cm-5cm).		
53702	Layer				Natural. Mid brown clayey clay with some patches of yellowish orange sandy sand geology. Compacted texture, the thick fraction (15%) contains rounded gravels (1mm-1cm), sub-rounded limestones (1cm-5cm), some flint nodules (1cm-5cm) and pebbles (1cm-5cm).		
Trench 538							
General description					Orientation	NE-SW	
Trench devoid of archaeology. Consists of ploughsoil and subsoil overlying the natural clay					Length (m)	30	
					Width (m)	1.8	
					Avg. depth (m)	0.48	
Context No.	Type	Fill Of	Width (m)	Depth (m)	Description	Finds	Date

53800	Layer			0.12	Ploughsoil. Dark brown silty clay. Friable texture, the thick fraction (10%) contains gravels (1mm-1cm), sub-rounded limestones (1cm-5cm) and some flint nodules (1cm-5cm).		
53801	Layer			0.1	Subsoil. Light brown clayey silt. Compacted texture, the thick fraction (5%) contains gravels (1mm-1cm), sub-rounded limestones (1cm-5cm) and some flint nodules (1cm-5cm).		
53802	Layer				Natural. Mid brown clayey clay with some patches of yellowish orange sandy sand geology. Compacted texture, the thick fraction (15%) contains rounded gravels (1mm-1cm), sub-rounded limestones (1cm-5cm), some flint nodules (1cm-5cm) and pebbles (1cm-5cm).		

Trench 539

General description		Orientation	NW-SE
Trench consists of ploughsoil and subsoil overlying the natural clay.		Length (m)	30
		Width (m)	1.8
		Avg. depth (m)	0.3

Context No.	Type	Fill Of	Width (m)	Depth (m)	Description	Finds	Date
53900	Layer			0.12	Ploughsoil. Dark brown silty clay. Friable texture, the thick fraction (10%) contains gravels (1mm-1cm), sub-rounded limestones (1cm-5cm) and some flint nodules (1cm-5cm).		
53901	Layer			0.14	Subsoil. Light brown clayey silt. Compacted texture, the thick fraction (5%) contains		

					gravels (1mm-1cm), sub-rounded limestones (1cm-5cm) and some flint nodules (1cm-5cm).		
53902	Layer				Natural. Mid brown clayey clay with some patches of white bits of chalk. Compacted texture, the thick fraction (15%) contains rounded gravels (1mm-1cm), sub-rounded limestones (1cm-5cm), some flint nodules (1cm-5cm) and pebbles (1cm-5cm).		
Trench 540							
General description						Orientation	NE-SW
Trench devoid of archaeology. Consists of ploughsoil and subsoil overlying the natural clay						Length (m)	30
						Width (m)	1.8
						Avg. depth (m)	0.45
Context No.	Type	Fill Of	Width (m)	Depth (m)	Description	Finds	Date
54000	Layer			0.15	Ploughsoil. Dark brown silty clay. Friable texture, the thick fraction (10%) contains gravels (1mm-1cm), sub-rounded limestones (1cm-5cm) and some flint nodules (1cm-5cm).		
54001	Layer			0.18	Subsoil. Light brown clayey silt. Compacted texture, the thick fraction (5%) contains gravels (1mm-1cm), sub-rounded limestones (1cm-5cm) and some flint nodules (1cm-5cm).		
54002	Layer				Natural. Mid brown clayey clay with some patches of yellowish orange sandy sand geology and bits of chalk. Compacted texture, the thick fraction (15%) contains rounded gravels (1mm-1cm), sub-		

					rounded limestones (1cm-5cm), some flint nodules (1cm-5cm) and pebbles (1cm-5cm).		
Trench 541							
General description					Orientation	NW-SE	
Trench devoid of archaeology. Consists of ploughsoil, a bleached horizon and head deposits overlying the bedrock from London Clay.					Length (m)	30	
					Width (m)	1.8	
					Avg. depth (m)	0.5	
Context No.	Type	Fill Of	Width (m)	Depth (m)	Description	Finds	Date
54100	Layer			0.15	Ploughsoil. Dark brown silty clay. Friable texture, the thick fraction (10%) contains gravels (1mm-1cm), sub-rounded limestones (1cm-5cm) and some flint nodules (1cm-5cm).		
54101	Layer			0.12	Subsoil. Light brown clayey silt. Compacted texture, the thick fraction (5%) contains gravels (1mm-1cm), sub-rounded limestones (1cm-5cm) and some flint nodules (1cm-5cm).		
54102	Layer				Natural. Mid brown clayey clay with some patches of yellowish orange sandy sand geology and bits of chalk. Compacted texture, the thick fraction (15%) contains rounded gravels (1mm-1cm), sub-rounded limestones (1cm-5cm), some flint nodules (1cm-5cm) and pebbles (1cm-5cm).		

Appendix B Finds Reports

B.1 Pottery

By Pete Banks

Introduction

B.1.1 A total of 274 sherds (3516g) of pottery were recovered from the evaluation. The pottery has been recorded direct to an Excel spreadsheet from which Appendix B (Table 1) is derived and which forms part of the project archive. The pottery was examined by context and quantified by sherd count and weight (grammes), using a x10 binocular microscope. The fabrics are described in accordance with the Historic England guidelines (Barclay *et al.* 2016) and the Prehistoric Ceramics Research Group guidelines (PCRG 2010). Late Iron Age and Roman pottery fabrics were assigned codes using OA's standard recording system for material of that date (Booth 2019). Forms identified by rim were given codes from OA's system. A concordance with the Essex fabric series classified by Chelmsford Archaeological Trust (Biddulph *et al.* 2015) and Going's (1987) type series of pottery from Chelmsford have been provided where possible.

B.1.2 The following prehistoric fabrics were noted:

- A2 Medium quartz sand fabric IA
- AF2 Medium quartz sand and flint-tempered fabric EIA?
- AG2 Medium quartz sand and grog-tempered fabric EIA?
- B2 Medium glauconitic sand fabric IA
- F2 Medium flint-tempered fabric LBA-EIA
- F4 Coarse flint-tempered fabric MBA
- FV2 Medium flint-tempered with organic inclusions fabric LBA-EIA
- G2 Medium grog-tempered fabric IA

B.1.3 The following late Iron Age and Roman fabrics were noted (NRFRC codes in brackets):

- C10 Shell-tempered ware
- E45 Late Iron Age/early Roman shelly grog-tempered ware
- E80 Late Iron Age/early Roman grog-tempered ware (SOB GT)
- E810 Late Iron Age/early Roman grog and sand tempered fabrics
- O20 Sandy oxidised ware
- O38 Oxidised Roman grog-tempered ware
- R10 Fine reduced ware
- R20 Sandy reduced coarseware
- R30 Medium sandy reduced ware
- S20 La Graufesenque South Gaulish samian ware (LGF SA)

B.1.4 The following form identified by rim was recorded (London type series in brackets):

- CA125 Bucket shaped jar with thickened square-ended rim (vertical)
- HC111 Tripartite bowl with round ended flaring rim

Context	Count	Weight (g)	MNV	EVEs	Fabric Code	Essex Fabric Series	Description	Spot-date
30611	9	109	1	0.03	F2		Flint-tempered fabric, Simple upright rim (100) x 1	LBA-EIA?
31107	3	3			F2		Flint-tempered fabric	LBA-EIA?
31108	2	9			F2		Flint-tempered fabric	LBA-EIA?
31114	3 1	7 1			R30 F2	GRS	Unsourced sandy grey ware Flint-tempered fabric	RB
32807	1	10			O38	GROG	Unsourced grog-tempered ware	RB
35104	1	27			R20	BSW	Unsourced black fired sandy ware	RB
35105	1	7			F2		Flint-tempered fabric	LBA-EIA?
37507	2	7			E80	GROG	Unsourced grog-tempered ware	LIA/ERB
37514	1	5			E45		Unsourced shelly grog-tempered ware	LIA/ERB
37608	3 1	12 5			E810 E80	GROG	Unsourced sandy grog-tempered ware Unsourced grog-tempered ware	LIA/ERB
38205	1	3			O20		Unsourced sandy oxidised ware	RB
40904	155	2958	1	0.14	F4		Coarse flint-tempered fabric. CA125 Deverel Rimbury bucket jar x 1 Exp rim with fingertip rim top dec and applied fingertip dec cordon	MBA
44505	4	107	1	0.06	FV2		Flint-tempered fabric with organic inclusions. HC Bowl with flaring rim?	EIA?
45204	3	7			A2		Sandy fabric	LATE PREH
45206	2 1	9 1			F2 B2		Flint-tempered fabric Glaucinitic sandy fabric	LATE PREH
45208	2 1 1 10	8 3 3 25			A2 AF2 G2 R10	GRF	Sandy fabric. Incised linear dec x 1 Flint and sand-tempered fabric Grog-tempered fabric Unsourced micaceous sandy grey ware	RB
45210	1 1	2 3			F2 C10	ESH/LSH	Flint-tempered fabric Unsourced shell-tempered ware	RB
45405	1 1	4 8			A2 FV2		Sandy fabric Flint-tempered fabric with organic inclusions	LATE PREH

Context	Count	Weight (g)	MNV	EVEs	Fabric Code	Essex Fabric Series	Description	Spot-date
45413	1	2			A2		Sandy fabric	RB
	1	5	1	0.05	R30	GRS	Un sourced sandy grey ware. Out-curved rim x 1	
45514	2	12			F2		Flint-tempered fabric	LBA-EIA?
45706	1	4			O20	RED	Un sourced sandy oxidised ware	RB
	1	8			C10	ESH/LSH	Un sourced shell-tempered ware	
46009	15	24			F2		Flint-tempered fabric	LBA-EIA?
46010	8	36			F2		Flint-tempered fabric	LBA-EIA?
46017	1	13			F2		Flint-tempered fabric	LBA-EIA?
46107	3	4			R30	GRS	Un sourced sandy grey ware	RB
	1	1			R20		Un sourced black fired sandy ware	
	1	2			AG2		Grog and sand-tempered fabric	
46204	1	2			O20	RED	Un sourced sandy oxidised ware	MC1-EC2
	1	3			E45		Un sourced shelly grog-tempered ware	
	1	1			C10	ESH/LSH	Un sourced shell-tempered ware	
	1	2			S20	SASG	La Graufesenque South Gaulish samian ware	
46603	1	2			O20	RED	Un sourced sandy oxidised ware	RB
48704	1	1			O20	RED	Un sourced sandy oxidised ware	RB
	1	1			E80	GROG	Un sourced grog-tempered ware	
49306	1	1			F2		Flint-tempered fabric	LATE PREH
	2	3			G2		Grog-tempered fabric	
49405	1	6			O20	RED	Un sourced sandy oxidised ware	RB
51905	3	10			F2		Flint-tempered fabric	LBA-EIA?
52104	2	12			F2		Flint-tempered fabric	LBA-EIA?
52106	3	385			F2		Flint-tempered fabric	LATE PREH
	2	3			A2		Sandy fabric	
52603	1	7			F2		Flint-tempered fabric	LBA-EIA?

Table 1: Summary and quantification of the pottery by context

Key: *EVE* estimated vessel equivalent; *MNV* minimum number of vessels; *LBA-EIA* late Bronze Age to early Iron Age; *IA* Iron Age; *LIA-ERB* late Iron Age to early Roman

Middle Bronze Age

- B.1.5 Pit 40903 produced 155 sherds (2958g) of handmade, coarse flint-tempered pottery (F4). The sherds were from a bucket shaped jar (CA) with an expanded, flat-topped rim. The vessel was decorated with applied cordons. Both the rim top and cordons were decorated with fingertip impressions. The style of vessel and decoration are consistent with the middle Bronze Age Deverel-Rimbury tradition. Similar vessel of middle Bronze Age date are recorded from Ardleigh, Essex (Brown 1999, 76), although this example was not as heavily decorated as some Ardleigh vessels defining the distinctive 'Ardleigh Urn' style.

Late Bronze Age to early Iron Age

- B.1.6 A total of 61 sherds (381g) of flint-tempered pottery (F2), some with quartz sand (AF2) or organic voids (FV2), caused by the carbonisation of organic material during firing, were recorded from the evaluation (Trenches 306, 311, 351, 445, 452, 454, 455, 460, 493, 519, 521 and 526). Four sherds (8g) of handmade, grog-tempered pottery (G2/AG2) were also recorded from Trenches 452, 461 and 493. Several flint-tempered sherds were overfired/'refired'. A rim sherd (FV2), from a possible tripartite bowl (HC) was recovered from Layer 44505. This style of vessel is known to date to the early Iron Age in the East Anglia region (Brudenell 2012, 199). The scarcity of diagnostic (rim or decorated) sherds makes dating uncertain. The use of flint-temper and grog-temper was common in East Anglia throughout parts of the Neolithic, Bronze Age and early Iron Age (*ibid.*). Some characteristics, such as the wall thickness, fabric coarseness/sorting and firing, are thought suggestive of later prehistoric dating in the late Bronze Age or early Iron Age range.

Iron Age

- B.1.7 Nine body sherds (24g) made in a sandy fabric (A2) were recovered from Trenches 452, 454 and 521. Although lacking in diagnostic features of form or decoration, these sherds probably date broadly to the Iron Age. A small body sherd (1g) made in glauconitic sandy fabric B2 is most likely of similar date.

Late Iron Age and Roman

- B.1.8 The late Iron Age and Roman pottery consisted largely of undiagnostic body sherds. A small group (9 sherds; 33g) of late Iron Age and early Roman transitional grog-tempered sherds (E45/E80/E810) were recorded from Trenches 375, 376, 462 and 487. The bulk of the Roman material comprised sandy oxidised (O20) and reduced (R10/R20/R30) coarsewares (Trenches 311, 351, 382, 452, 454, 457, 461, 462, 466, 487 and 494). Most were unfeatured body sherds and could only be assigned a broad Roman date. A small number of grog-tempered (O38) and shell-tempered sherds (C10) were also assigned a broad Roman date. One body sherd (2g) of La Graufesenque South Gaulish samian ware (S20) was recorded from ditch 46203. This can be dated to the mid-1st to early 2nd centuries AD (Webster 1996, 3).

Discussion

- B.1.9 The pottery was in moderately poor condition with surfaces and fractures exhibiting signs of heavy wear. The mean sherd weight (weight divided by sherd count) of 13g is skewed by the presence of the Deverel-Rimbury vessel, due to its thick walls. Without this, the mean sherd weight of just 4.9g illustrates the highly fragmented condition of the assemblage.

- B.1.10 The pottery provides evidence of activity in the vicinity of the site spanning the middle Bronze Age to Roman periods.
- B.1.11 The Deverel-Rimbury vessel provides some evidence for non-funerary activity during the middle Bronze Age. This material was limited to a single pit and the extent/survival of the activity of the period is unclear.
- B.1.12 Due to its poor condition and scarcity of diagnostic features, much of the remaining prehistoric assemblage could be dated only broadly, although late Bronze Age to early Iron Age and middle Iron Age elements appear to be present.
- B.1.13 The late Iron Age to Roman assemblage provided some evidence for activity dating to the 'transitional' period (1st centuries BC/AD). Most material, however, could only be broadly dated within the Roman period.
- B.1.14 Its small size and absence of diagnostic material prevent any further meaningful analysis of the group overall.

Conservation, discard and retention of material

- B.1.15 The pottery reported on here has the potential to inform future research through re-analysis and thus it is recommended that all the pottery is retained. This follows the advice set out in the 'Standard for Pottery Studies in Archaeology' (PCRG, SGRP, MPRG 2016).

B.2 Post-Roman Pottery

By Sue Anderson

Introduction

- B.2.1 Ninety-two sherds of pottery weighing 489g were collected from seven contexts. Quantification was carried out using sherd count, weight and estimated vessel equivalent (eve). A full quantification by fabric, context and feature is available in the archive. All fabric codes were assigned from the author's post-Roman fabric series, and fabrics and forms were identified based on the Essex and Colchester fabric series (Cotter 2000). Form terminology follows MPRG (1998).

Medieval

- B.2.2 Table 2 shows the quantification by fabric; a summary catalogue by context is included as Table 3 and the full catalogue is available as an Access database.

Description	Count	Weight (g)	MNV	EVEs	Fabric	Date range
Early medieval ware shelly	1	2	1		12A	11th-e13th C
Early medieval ware shelly/sandy	9	50	9	0.08	12B	11th-e13th C
Early medieval ware sandy/shelly	35	183	3		12C	11th-e13th C
Early medieval ware	6	37	4		13	11th-e13th C
Medieval coarseware	14	61	9		20	12th-14th C
Sandy orange wares	22	117	11		21	13th-15th C
Mill Green Ware	2	3	2		35	13th-e15th C
Sandy orange/redware	1	16	1		21/40	13th-17th C
Post-medieval redware	2	20	2		40	16th-17th C
Total	92	489	42	0.08		

Table 2. Pottery quantification by fabric

- B.2.3 Early medieval wares (Fabrics 12A-C and 13) were the most frequent types recovered. Most were body fragments in medium to coarse sandy/shelly fabrics with other local inclusions such as clay pellets and mica. The majority were oxidised with a reduced core. Two rims were found, both from jars, in ditch fill 37403 and natural feature fill 34104. The rim types were upright beaded (Colchester Type C1) and ?upright with tapered everted tip (Type B2 or B4?). These types both have a broad date range spanning the 11th to early 13th centuries, although Cotter suggests that Type B2 starts towards the end of the 11th century.
- B.2.4 High medieval wares comprised several body fragments of fine to coarse sandy coarsewares (Fabric 20), mostly grey but occasionally oxidised. Sandy orange wares (Fabric 21) included several sherds which can be classified as late medieval and transitional, including base fragments with internal green glaze. The group included a variety of very fine silty to quite coarse sandy fabrics, but few were glazed. Three joining body sherds in ditch fill 37507 were glazed brown externally and were in a hard red fabric with sparse to moderate coarse sand, perhaps from a coarse London-type ware. Two heavily abraded fragments of slip-decorated and combed Mill Green ware were also found. One base fragment with sparse clear glaze internally could be of late medieval or post-medieval date.

Post-medieval

- B.2.5 Post-medieval redwares comprised two base fragments, one a brown-glazed footstand type in ditch fill 32805, and the other a ?flat type with internal orange glaze from ditch fill 37403.

Context	Count	Weight (g)	Fabric	Type	MNV	Form	Rim	Date range
31113	1	1	12B	U	1			11th-e13th C
32805	1	13	40	B	1			16th-17th C
34104	2	3	13	R	1	jar	B2/B4?	11th-e13th C
37403	1	23	13	B	1			11th-e13th C
37403	21	150	12C	BU	1			11th-e13th C
37403	12	28	12C	U	1			11th-e13th C
37403	1	2	12B	U	1			11th-e13th C
37403	1	2	12A	U	1			11th-e13th C
37403	1	14	12B	R	1	jar	C1?	11th-e13th C
37403	2	11	20	U	1			12th-14th C
37403	3	9	20	U	1			12th-14th C
37403	2	4	20	U	1			12th-14th C
37403	2	27	20	U	1			12th-14th C
37403	2	5	12C	U	1			11th-e13th C
37403	1	7	13	U	1			11th-e13th C
37403	5	14	21	U	3			13th-15th C
37403	2	15	21	DU	1			13th-15th C
37403	2	4	13	U	1			11th-e13th C
37403	3	12	21	U	1			13th-15th C
37403	3	9	21	U	1			13th-15th C
37403	3	38	21	B	1			13th-15th C
37403	1	7	40	B	1			16th-17th C
37507	4	19	12B	U	4			11th-e13th C
37507	1	10	12B	D	1			11th-e13th C
37507	1	4	12B	U	1			11th-e13th C
37507	4	6	20	U	4			12th-14th C
37507	1	4	20	U	1			12th-14th C
37507	1	5	21	U	1			13th-15th C
37507	1	14	21	B	1			13th-15th C
37507	1	5	21	B	1			13th-15th C
37507	3	5	21	D	1			13th-15th C
37508	1	2	35	D	1			13th-e15th C
37508	1	16	21/40	B	1			13th-17th C
38207	1	1	35	D	1			13th-e15th C

Table 3: Pottery catalogue

Distribution

- B.2.6 Table 4 shows the distribution of fabrics by context, with suggested spot dates. Several contexts appear to date to the early medieval or high medieval periods, although the majority were later, but as most of the contexts were ditches it is likely that they were backfilled with material from surrounding ?ploughsoil, which explains the variety of fabrics and dates within the fills. A number of the early medieval sherds and some of the medieval ones were small and abraded and were probably redeposited. The largest single group was recovered from primary ditch fill 37403, but this group included a high proportion of residual material.

Context	Feature	Type	Fabrics	Spot date
31113	31112	ditch	12B	11th-e13th C
32805	32804	ditch	40	16th-17th C
34104	34103	natural feature	13	11th-e13th C
37403	37402	ditch	12A 12B 12C 13 20 21 40	16th C?
37507	37509	ditch	12B 20 21	15th C?
37508	37506	ditch	35 21/40	16th C?
38207	38206	ditch	35	13th-e15th C

Table 4. Pottery by context with suggested spot dates

Discussion

- B.2.7 Overall, the group is typical of assemblages of this broad date range in this part of Essex. The early medieval wares were in relatively coarse, largely oxidised fabrics comparable with those found across much of Essex. It is likely that there were several pottery production centres for this material in the county. Only two rims were present, and both were Essex forms. Although a number of the high medieval sherds contained relatively coarse quartz sand inclusions, the fabrics were not typical of Colchester ware and were probably made in south Essex or possibly Kent. Few glazed wares were present, and most were unsourced, although two were probably from the Mill Green production site at Ingatestone, which is a common find in London.

B.3 Ceramic Building Material

By Pete Banks

Introduction

- B.3.1 A total of 11 fragments of ceramic building material (CBM) weighing 153g were recovered from the evaluation; they are categorised in Table 5 below.
- B.3.2 The assemblage of CBM was highly fragmented and comprised pieces of indeterminate form (5 fragments) and flat tile (6 fragments). The CBM of indeterminate form from Trenches 354, 382, 442, and 526 was not closely dateable.

Context	Count	Weight (g)	Spot-date	Form	Fabric Code	Description
35406	1	7	Undated		Oxidised fine sandy fabric with clay pellets	Amorphous lumps
37205	1	8	Post-med/mod	Flat	Oxidised fine sandy fabric	Tile x 1
37507	1	12	Post-med/mod	Flat	Oxidised fine sandy fabric	Tile x 1
37608	1	20	Post-med/mod	Flat	Oxidised fine sandy fabric	Tile x 1
38205	1	3	Undated		Oxidised fine sandy fabric	Amorphous lumps
44204	1	2	Undated		Oxidised fine sandy fabric with clay pellets	Amorphous lumps
51404	1	33	Post-med/mod	Flat	Oxidised fine sandy fabric with mica and clay pellets	Tile x 1
52603	4	68	Post-med/mod	Flat	Oxidised fine sandy fabric with clay pellet, micaceous or calcareous inclusions	Tile x 2

Table 5: Summary of ceramic building material by context

- B.3.3 Six fragments of flat tile, from Trenches 354, 372, 375, 376, 382, 442, 514 and 526, were of post-medieval or modern form. The tile fragments were made in fine silty oxidised fabrics some with micaceous, calcareous or clay pellet inclusions.
- B.3.4 The ceramic building material assemblage was small and indicative of low levels of activity that required this type of material.

Retention and discard

- B.3.5 The CBM assemblage is undated or of post-medieval/modern date and retention of the material is not considered necessary.

B.4 Fired Clay

By Pete Banks

- B.4.1 A total of 167 fragments (1398g) of fired clay were recovered; the assemblage is listed in Table 6 below.
- B.4.2 The fired clay assemblage was largely made in soft fired oxidised coarse, medium and fine sandy fabrics, some with clay pellet, ferrous, flint or organic inclusions. The assemblage was poorly preserved, and the majority of fragments did not exhibit any diagnostic features.

Context	Count	Weight (g)	Date	Fabric	Form	Form notes
30603	1	4		fscp		Amorphous lumps
30611	1	21		cs		Amorphous lumps
30611	1	3		fscp		Amorphous lumps
32805	1	5		fscp		Amorphous lumps
44505	2	122	IA	cscpc	poss. loomweight	Perforated corner
45204	2	18		fscp		Amorphous lumps
45204	1	20	IA	cs	poss. loomweight	Corner fragment
45204	1	14		fsf		Amorphous lumps
45208	4	8		fs		Amorphous lumps
45210	2	3		fssh		Amorphous lumps
45210	1	7		fs		Amorphous lumps
45213	2	22		cs		Amorphous lumps
45213	2	6		fs		Amorphous lumps
45405	2	9		fscp		Amorphous lumps
45409	1	3		fscp		Amorphous lumps
45509	1	82	IA	cscpc	poss. loomweight	
45514	1	40		cscpc	poss. daub	Rod impression x 1
46004	24	64		fs		Amorphous lumps
46004	1	5		fscpc		Amorphous lumps
46004	15	102		fsfe		Amorphous lumps
46004	28	225		msv		Amorphous lumps
46009	46	427		fs	Poss. daub	Flat surfaces x 4, rod impressions x 1
46017	19	114		fs		Amorphous lumps
46017	4	55		fsf		Amorphous lumps
46020	4	19		fsfe		Amorphous lumps

Table 6: Catalogue of fired clay

- B.4.3 Three fragments of fired clay, recovered from layer 44505 and ditches 45202 and 45506, may represent fragments of triangular weights. Such objects are usually identified as loomweights for use with vertical, warp-weighted looms. This style of triangular loomweight was commonly used throughout the Iron Age. Comparable examples include those of middle/late Iron Age date from Little Waltham, Essex (Drury 1978, 112–113) and from Heybridge, Essex (Tyrell 2015, fig.539 no.17-19). Evidence for continued use into the Roman period is rare, however, examples thought to date into the 2nd century AD are known from Ardleigh, Essex (Major 1999, 157).
- B.4.4 Six fragments preserved flat surfaces or round sectioned, probable wattle, impressions. It is possible these represent fragments of burnt daub (Tree throw 45513 and ditch 46007). This material is most likely derived from domestic or industrial structures and has probably preserved as a result of accidental 'firing'.

B.5 Flint

By Jacky Sommerville

Introduction

- B.5.1 A small assemblage of 46 worked flints (207g) and 20 pieces of burnt, unworked flint (442g) was recovered via the hand-excavation and bulk soil sampling of 22 deposits from Trenches 306, 311, 328, 351, 375, 406, 409, 435, 454-5, 457, 460-2 and 482 (Table 7). Two natural flints (26g, from fill 31114 of posthole 31110 and fill 35105 of ditch 35103) have been discarded.

Methodology

- B.5.2 The artefacts were recorded according to broad debitage/artefact type as defined by Butler (2005) and catalogued into an MS Excel spreadsheet. Dating was attempted, where possible. Additional information on condition (edge damage/microflaking), and state of the artefact (burnt or broken) was also recorded.

Category Type	Number
Blade	2
Flake	21
Chip	20
Shatter	1
Blade index	8.3% (2/24)
Core, discoidal (flakes)	1
Core, made on a flake (flakes)	1
Total	46

Burnt unworked	20/442g
No. burnt (% excluding chips)	3/26 (11.5%)
No. broken (% excluding chips)	9/26 (34.6%)
No. cores/related debitage (% excluding chips)	2/26 (7.7%)

Table 7: Breakdown of flint assemblage by type

Raw material and condition

- B.5.3 All of the lithics were made using flint. Cortex is present on 12 items – it is chalky on ten and abraded on two. This indicates a reliance mainly on chalk or clay-with-flints sources. The nearest chalk bedrock, of the White Chalk Subgroup, lies 2km to the south (BGS 2021) so chalk flint would have been available locally.
- B.5.4 Slight or no edge damage was recorded on 15 items and moderate edge damage on five. Three flints are burnt and nine are broken (Table 7).

Provenance

- B.5.5 The 13 chips recovered from fill 40904 of pit 40903 were associated with pottery of middle Bronze Age date. A further eight flints were recorded with flint-tempered pottery of probable late Bronze Age/early Iron Age date – three flakes from fill 30611 of ditch 30609, two flakes and two blades from fill 46009 of ditch 46007, and one flake from fill 46017 of ditch 46015. Most of the other lithics were retrieved as residual finds from subsoil or deposits which produced pottery of late Iron Age, Roman or medieval date.

Discussion

- B.5.6 The two blades, from fill 46009 of ditch 46007, are probably of Mesolithic or early Neolithic date. However, one of these is in a moderately edge-damaged condition and seems likely to be redeposited. None of the other flints are chronologically diagnostic and only broad prehistoric dating can be applied to them.

B.6 Metalwork

By Pete Banks

Introduction

- B.6.1 Six fragments of metalwork (239g) were recovered from the evaluation and are summarised in Table 8 below.

Results

- B.6.2 Two fragments of iron nails were recovered from ditch 37402 and sample 95, taken from ditch 34304. The latter is square shafted and probably handmade. A fragment of iron horseshoe, recovered from ditch 37509, is most likely of late medieval date. Its form is consistent with a late medieval Type 4 horseshoe (Clark 1995, 88). A curved fragment of iron was recorded from the subsoil of Trench 450. The fragment is square sectioned, hook-shaped and approximately 100mm in length. Its function could not be determined. A triangular fragment of iron, recorded from ditch 45506, is most likely the tip of a knife blade, although its full profile was not preserved.
- B.6.3 Ditch 44303 produced a flat strip of copper alloy approximately 25mm x 10mm. The fragment is scored with two deep lines on one surface. It was not possible to determine the function of the object.

Context	Material	Count	Weight (g)	Description	Date
34305	Iron	1	1	Nail	
37403	Iron	1	15	Nail	
37507	Iron	1	87	Horseshoe	Late medieval
44304	Copper Alloy	1	10	Object	
45001	Iron	1	114	Hook	
45509	Iron	1	12	Blade	

Table 8: Summary of metalwork by context

C.1 Environmental Samples

By Emma Aitken

Introduction

C.1.1 A total of 22 samples were assessed primarily for charred plant remains.

Method

C.1.1 The samples were processed in their entirety at Cotswold Archaeology using a water flotation machine. The flots were collected in a 250µm mesh and heavy residues in a 500µm mesh and dried. The residue fractions were sorted by eye and with the aid of a magnet while the flot material was sorted using a low power (x10) binocular microscope to extract cereal grains and chaff, smaller seeds and other quantifiable remains.

Results

C.1.2 Sample and CPR flot data is summarised in Table 9. Any dates discussed within this report have been obtained through the spot dating of finds.

C.1.3 **Trench 343.** Sample 95 from fill 34305 of undated ditch 34304 contained a moderately small quantity of charcoal fragments larger than 2mm in size. A single charred vetch/wild pea (*Vicia/Lathyrus* sp.) seed was also noted alongside a single lesser celandine (*Ranunculus ficaria*) tuber fragment.

C.1.4 **Trench 390.** Fill 39006 (sample 94) from undated ditch 39003 contained charcoal fragments larger than 2mm in size in a moderate quantity alongside a small number of wheat (*Triticum* sp.) grains, free-threshing wheat (*Triticum turgidum/aestivum* type) grains, oat (*Avena* sp.) seeds and a single stinking chamomile (*Anthemis cotula*) seed.

C.1.5 **Trench 409.** Two samples were collected from middle Bronze Age pit 40903, sample 111 from fill 40904 and sample 112 from fill 40906. Both assemblages produced charcoal in a moderately large quantity with only a small number of cereal grains being noted, including those of barley (*Hordeum vulgare*).

C.1.6 **Trench 454.** Sample 125 from fill 45409 of undated posthole 45408 contained a large quantity of charcoal fragments larger than 2mm in size.

C.1.7 Sample 137 from fill 45413 of Roman pit 45412 contained a small number of charcoal fragments larger than 2mm.

C.1.8 **Trench 457.** Sample 116 from fill 45704 of prehistoric ditch 45703 contained a small number of charcoal and cereal grain fragments.

C.1.9 Sample 118 from fill 45706 of Roman ditch 45705 also contained a small number of charcoal and cereal grain fragments.

C.1.10 **Trench 460.** Sample 142 from fill 46004 of hearth 46003 contained less than five fragments of charcoal that are larger than 2mm in size.

- C.1.11 Fill 46009 (sample 150) of prehistoric ditch 46007 contained a large number of charcoal fragments greater than 2mm in size.
- C.1.12 Sample 151 from fill 46012 of undated pit 46005 contained a small amount of charcoal fragments greater than 2mm in size.
- C.1.13 **Trench 461.** Fill 46104 (sample 117) from undated ditch 46103 contained a small number of charcoal fragments greater than 2mm in size.
- C.1.14 Fill 46107 (sample 138) from late Iron Age to early Roman ditch 46106 contained a small number of charcoal fragments greater than 2mm in size.
- C.1.15 **Trench 464.** Sample 140 from fill 46403 of undated ditch 46402 contained a small number of charcoal fragments larger than 2mm in size.
- C.1.16 **Trench 482.** Sample 141 from fill 48211 of undated ditch 48210 contained a very small number of charcoal fragments that are larger than 2mm in size.
- C.1.17 **Trench. 505.** Fill 50504 (sample 115) from undated ditch 50503 contained a large quantity of charcoal fragments larger than 2mm. A very small number of charred cereal grains were observed in the assemblage but were too poorly preserved for further identification.
- C.1.18 **Trench 516.** Sample 89 from fill 51604 and sample 90 from fill 51605 of undated hearth or tree throw 51603 both contained small amounts of charcoal fragments.
- C.1.19 **Trench 519.** Fill 51905 (sample 88) of prehistoric ditch 51904 contained a moderately low quantity of charcoal fragments that are larger than 2mm. A single charred stinking chamomile seed was noted in the assemblage.
- C.1.20 **Trench 520.** Sample 87 from fill 52004 of undated ditch 52003 contained a moderately small quantity of charcoal fragments alongside a single charred oat/brome grass (*Avena/Bromus* sp.) seed.
- C.1.21 **Trench 521.** Samples 91 and 92 from fills 52106 and 52104 (respectively) of Prehistoric ditches 52105 and 52103 contained moderately high to high numbers of charcoal fragments larger than 2mm in size. Sample 92 of prehistoric ditch 52103 also contained a small number of hulled wheat (emmer or spelt (*Triticum dicoccum/spelta*)) grains and glume fragments.

Discussion

- C.1.22 The only mode of preservation evident in the sampled contexts and features is charring, with the quantity and quality of the charred remains being relatively low. Samples 91, 111, 115, 125, and 150 from ditch 52105, pit 40903, ditch 50503, pit 45408, and ditch 46007 (respectively) produced the greatest quantities of charcoal, and further identification of the charcoal would be possible if considered informative within the wider context of the site. Sample 94 from ditch 39003 contained the largest number of cereal grains and weed seeds, and further identification would be possible on the grains and weed species present if deemed worthwhile and if this ditch becomes dated.
- C.1.23 The features that show the best potential are the pits and some of the ditches. The remaining ditches produced smaller numbers of charcoal fragments, which possibly suggests that these features lay further away from the areas of occupation.

Sample	Context	Feature/Deposit	Date	Sample vol. (L)	Flot vol. (ml)	Charcoal >2mm	Grain	Chaff	Weeds
95	34305	Ditch 34304	-	22	27	++	-	-	+
94	39006	Ditch 39003	-	20	35	+++	++	-	+
111	40904	Pit 40903	MBA	15	40	++++	+	-	-
112	40906	Pit 40903	-	16	17	+++	+	-	-
125	45409	Pit 45408	-	2	12	++++	-	-	-
137	45413	Pit 45412	RB	13	2	++	-	-	-
116	45704	Ditch 45703	PrH	33	110	++	+	-	-
118	45706	Ditch 45705	RB	32	100	++	+	-	-
142	46004	Other cut 46003	-	32	40	+	-	-	-
150	46009	Ditch 46007	PrH	40	70	++++	-	-	-
151	46012	Pit 46005	-	24	55	++	-	-	-
117	46104	Ditch 46103	-	32	55	++	-	-	-
138	46107	Ditch 46106	LIA- ERB	34	25	++	-	-	-
140	46403	Ditch 46402	-	36	25	++	-	-	-
141	48211	Ditch 48210	-	40	25	+	-	-	-
115	50504	Ditch 50503	-	38	55	++++	+	-	-
89	51604	Hearth/Tree Throw 51603	-	18	15	+	-	-	-
90	51605	Hearth/Tree Throw 51603	-	18	20	+	-	-	-
88	51905	Ditch 51904	PrH	32	20	++	-	-	+
87	52004	Ditch 52003	-	30	32	++	-	-	+
91	52106	Ditch 52105	PrH	32	23	++++	-	-	-
92	52104	Ditch 52103	PrH	38	20	+++	+	+	-

Table 9: Assessment of CPR flots

Key: +=present (up to 5 items), +=frequent (5-25), +++=common (25-100), ++++=abundant (100+). (PrH = Prehistoric)

Recommendations

- C.1.24 The flots warrant retention until all works on site are complete, with only one flot having the potential to warrant further analysis (sample 94), with the assumption that the feature can be dated.
- C.1.25 The charcoal from samples 91, 111, 115, 125, and 150 could potentially be considered for further identification as part of a large material assemblage in the event of further excavation and assessment at the site. This would only be warranted if the features proved to be of archaeological significance and could be dated.

C.2 Human Remains

By Sharon Clough

Introduction and provenance

- C.2.1 Burnt bone from one context (46009) in Trench 460 was received for analysis. Deposit 46009 was sampled (150) and recovered from the fill of ring ditch 46007 which contained late Bronze age/late Iron Age pottery. This was the secondary fill of the ditch, which was a dark grey, brown compact silty clay with frequent charcoal inclusions. The burnt bone was not identified as human in the field, and as such how much of the deposit has been collected for analysis is undetermined.

Methodology

- C.2.2 The deposit was processed by wet sieving and then sorted into fractions of >10mm, 10-5mm, 5-2mm and 2–0.5mm. These were further sorted to separate the bone from extraneous material such as stones.
- C.2.3 All bone was analysed to confirm species (e.g., human or animal), record colour, weight and maximum fragment size. Each fraction was examined for identifiable bone elements. The minimum number of individuals (MNI) present was estimated based on the identification of repeated elements and/or the presence of juvenile and adult bones in the same deposit. It was not possible to estimate age or sex.

Results

- C.2.4 A summary of the findings is given in Table 10. Information on fragmentation and skeletal elements represented is provided in Tables 11 and 12 respectively.

Context	Type	Date	Sample no.	weight (g)	Colour	Identification	Age	Sex	Inclusions/ staining	Non-metrics/ pathology/ burnt and unburnt animal bone
46009	Fill of ring ditch 46007	LBA-LIA	150	79.2	White: 95% black: 5%	Human multiple identified fragments	adult	?	0	MNI = 1

Table 10: Burnt bone - Osteological summary

Context	Weight (g)	>10mm (g)	10-5mm (g)	5-2mm (g)	Max. frag. size
46009 Cut 46007	79.2g	54.3 (68.6%)	18.3g (23.1%)	6.6 (8.3%)	58mm

Table 11: Burnt bone - Summary of fragmentation

Context 46009

- C.2.5 Identified fragments included femur shaft, tibia shaft, ulna proximal third and radial shaft as well as the easily identified cranial vault fragments (Table 12). The total weight of the bone from 46009 was 79.2g and the largest bone fragment was a piece of femur shaft which measured 50mm.
- C.2.6 Due to the way the burnt remains were collected it is possible that there was a bias towards larger fragments (Table 11), so any inference from the fragmentation levels may not be a true representation. Suffice to say the larger fragments enabled identification of elements.
- C.2.7 Approximately 95% of the deposit comprised fragments which were white, the remainder comprising two fragments, which had black sandwiched in the middle of outer white.
- C.2.8 There were no repeated elements, nor landmarks indicating conflicting age or sex estimations. Therefore, it represents a minimum of one individual. It was not possible to estimate the sex of any of the bones, because there were no diagnostic features present. The overall size and morphology of the bones are consistent with an adult. No pathology or non-metric traits were observed.

Skeletal Element							
Context	Skull	Axial	Upper Limb	Lower Limb	Unid. Long Bone	Unid. Other	TOTAL
46009	fragments vault 10.9g (13.8%)	None	Ulna prox. 1/3 shaft Radial shaft 10.3g (13%)	Femur shaft Tibia shaft 27.5g (34.7%)	None	30.5g (38.5%)	79.2g

Table 12: Burnt human bone - Summary of identified elements

Discussion

- C.2.9 The deposit comprised a low quantity of bone from fill 46009 of a possible ring ditch which contained late Bronze Age to late Iron Age pottery. The total weight of the deposit is well below the expected range for an entire individual from modern and archaeological deposits (1000-3600g McKinley 2000, 404 and 600-900g, McKinley 2013, 154). The nature of the recovery of the deposit along with modern disturbance will have had a significant impact on the recovered total weight of bone. It is though well known that the entire cremated individual was rarely deposited in the ground and a token amount is frequently recovered (McKinley 2013, 154).
- C.2.10 The bones primarily comprised cranial, lower limb or upper limbs. The material represents at least one adult. No pathology was observed.
- C.2.11 Overall, the bones were well burnt, or predominantly white (fully oxidised), indicating pyre temperatures in excess of 600°C (McKinley 2004, 11). This suggests that the corpse had been placed on the pyre in such a way as to maintain a consistent high temperature and oxygen supply (McKinley 2013, 158). A high proportion of fully oxidised bone is a common observation in archaeological cremation burials (McKinley 2006, 84). The black bone sandwiched between the outer white table

indicates that not all the areas were exposed for long enough to fully calcine the bone. It may be that they were further away from the heat source or insulated from oxygen and heat because of thicker areas of soft tissue and/or objects/clothing on the corpse (McKinley 1989, 65; McKinley 2013, 158).

- C.2.12 The loss of bone from not being identified in the field and a likely level of truncation as it was the upper most fill means that it is impossible to say how representative these observations are of the original deposit. However, the general observations are typical for the prehistoric period in Britain. Further investigation of the ring ditch and associated features may aid in the interpretation of the deposit.

Licence status and retention

- C.2.13 The assemblage is currently held at Oxford Archaeology under Ministry of Justice burial licence 20-0166. This licence is valid until 17th August 2025. Considering the potential that further works will be undertaken in the area, it is recommended that the assemblage is retained for future research. The licence should therefore be deferred by application to the Ministry of Justice, stating retention in the local receiving museum.

C.3 Animal Bone

By Andy Clarke

Introduction

- C.3.1 Animal bone amounting to 88 fragments (813g) were recovered via hand excavation and the processing of bulk soil samples from the fill of 24 ditch features. There was very limited direct association with datable material, but those artefacts recovered dated broadly to the late Bronze Age to the early Iron Age.
- C.3.2 The assemblage was identified using the Cotswold Archaeology reference collection. The condition of the material was assessed according to weathering stage where 0 indicates excellent preservation and 5 very poor preservation (Behrensmeyer, 1978). Where damage was present and re-fitting was possible, fragments were counted as a single bone.

Context	Cut	Count	Weight	Feature Type	Condition	Species	Element	Side	Phase
34108	34107	1	49	Ditch	3	Horse	Molar		
34108	34107	1	41	Ditch	3	Horse	Molar		
34108	34107	1	59	Ditch	3	Horse	Molar		
34108	34107	1	43	Ditch	3	Horse	Molar		
36207	36206	1	48	Ditch	4	Horse	Molar		
37508	37506	3	9	Ditch	3	MM	LB		
37508	37506	14	12	Ditch	4	Indent.			
44505		18	41	Alluvium	5	Indent.			EIA
45204	45203	1	17	Ditch	3	Cattle	Skull		LP
45204	45203	1	16	Ditch	3	Cattle	Vertebrae		LP
45213	45212	1	6	Ditch	4	Cattle	Molar		
45509	45506	1	11	Ditch	3	Cattle	Molar		
45509	45506	1	3	Ditch	3	Cattle	Molar		
45509	45506	1	17	Ditch	3	Cattle	Astragalus		
45509	45506	1	4	Ditch	3	Cattle	1st phalanx		
45509	45506	1	4	Ditch	3	Cattle	1st phalanx		
45509	45506	1	20	Ditch	4	Cattle	Pelvis		
45509	45506	1	18	Ditch	4	Cattle	Pelvis		
45509	45506	1	3	Ditch	3	S/G	Molar		
45509	45506	1	3	Ditch	3	S/G	Molar		
45509	45506	1	38	Ditch	3	Horse	Astragalus		
45509	45506	1	123	Ditch	4	Horse	Tibia	Left	
45509	45506	2	26	Ditch	3	LM	LB		
45509	45506	32	202	Ditch	4	Indent.			

Table 13: Summary of animal bones by context

S/G = sheep/goat; LM = large size mammal; MM = medium size mammal; Indent. = indeterminate; LB = long bone shaft fragment

Description

- C.3.3 The material was highly fragmented and only moderately well preserved, a combination of factors resulting in 78% of the assemblage being unidentifiable to species level. However, it was possible to confirm the presence on site of cattle (*Bos taurus*), sheep/goat (*Ovis aries/Capra hircus*) and horse (*Equus caballus*) with each of these species identified almost exclusively from meat-poor skeletal elements such as the skull or the bones of the lower limbs and feet. Although no osteological remains were recovered, much of the assemblage showed evidence of canid gnawing, indicating that dogs (*Canis familiaris*) were a common presence on site.

	Late Prehistoric	Undated
Cattle	2	8
Sheep/goat		2
Horse		7
Medium mammal		3
Large mammal		2
Total Mammal	2	22
Total NISP	2	22

Table 14: Number of identifiable species (NISP) by period

- C.3.4 The remains of cattle were most common with 10 fragments (116g) recovered. As stated, the majority were bones low in meat yield. However, occasional meat-rich bones were also identified such as a vertebra from deposit 45204 and a partial pelvis from 45509, both of which displayed clear chop marks, suggesting a possible origin in butchery waste.
- C.3.5 A limited amount of sheep/goat and horse bone was also recovered. However, with only two and seven fragments respectively, most of which were loose molar teeth, there is little useful interpretive information to be gained other than species identification.

Appendix D Geoarchaeology Assessment

By Thomas Bruce and edited by Elizabeth Stafford

Introduction

- D.1.1 The geoarchaeological component of the evaluation works undertaken within Land Parcels (Land Parcels) 43, 45A-E and 46, situated within the western middle reaches of the Mar Dyke valley, comprised the targeted recording of sedimentary sequences exposed in trenches to supplement standard archaeological recording. In addition, the opportunity was taken to drill a transect of purposive boreholes (Transect 1) to investigate and sample the more deeply buried sequences present within the Mar Dyke floodplain. The deposits anticipated, based on a review of previous geotechnical data, included alluvium and potentially waterlogged organic deposits associated with palaeochannel sequences, as well as Pleistocene Head (and perhaps fluvial) deposits overlying London Clay bedrock.
- D.1.2 The focus of the evaluation was primarily to assess the geoarchaeological potential of the Holocene sedimentary sequences. The Pleistocene deposits are to be investigated in detail as part of a separate phase of purposive test pits and any information in this report is provisional, intended to provide additional information beyond that provided by geotechnical data.
- D.1.3 As stated in the WSI (which also covers the low-lying ground of the Mar Dyke Basin across Land Parcels 47, 48A-H, detailed in a separate report) the main aims of the evaluation were to:
- determine the degree of complexity of any surviving horizontal or vertical stratigraphy;
 - investigate areas where topography indicates the likelihood of deep deposit sequences for evidence of buried archaeological horizons and palaeoenvironmental sequences;
 - investigate and record the extent, character and chronology of sedimentary sequences occurring within and adjacent to floodplains, as well as those contained within palaeochannels;
 - use the data obtained to refine existing geoarchaeological deposit models.
- D.1.4 More specific objectives include:
- establish the extent, depth and complexity of alluvial, colluvial and slope deposits;
 - determine whether buried archaeological activity is preserved beneath or within any of these deposits;
 - clarify whether the wider Mar Dyke valley is of largely late Pleistocene date, or if earlier Palaeolithic channel deposits and sediments associated with the 'Ockendon meander' survive within it;
 - establish the former course(s) and complexity of the late Glacial and Holocene channel system of the river, and date its development;
 - clarify whether there are successive sequences of channel deposits preserved within the river valley and examine evidence for activity along channel edges and across the wider alluvial floodplain;

- identify areas along the edge of the former palaeochannels and within the wider Mar Dyke floodplain, including any floodplain islands or areas which would have only received shallow seasonal inundation, that may have been used for human activity in the past.
- D.1.5 The area under investigation is situated on the western side of the middle reaches of the Mar Dyke River valley, located to the west of the modern, canalised, course of the river. Land Parcels 45A, 45B and 45C are immediately adjacent to the current river channel, extending from its western banks, across the floodplain, to the foot of the valley slopes in the west. Land Parcel 45A is the most southerly, with 45B and 45C further north. Land Parcel 45D is located to the north-west of Land Parcel 45C on slightly higher ground on the lower slopes of a shallow valley promontory, which occur along the edges of the Mar Dyke valley. Land Parcel 46 is also on this higher ground, to the north-west of Land Parcel 45D and traverses along a NE-SW aligned dry valley. Land Parcel 45E is situated north and north-west of Land Parcel 46 on the northern side of the dry valley and Land Parcel 43 is further west of Land Parcel 45E on higher ground at the head of the dry valley.
- D.1.6 The BGS maps the underlying bedrock geology as London Clay throughout all the land parcels. The mapped superficial geology varies from Head deposits within the dry valley and Mar Dyke river valley slopes to alluvium throughout the Mar Dyke floodplain.
- D.1.7 The study area has been previously reviewed as part of the scheme-wide Palaeolithic and Quaternary Deposit Model (PQDM) where areas were split into Palaeolithic–Quaternary (PQ) Zones (Wenban-Smith and Bates 2020). Land Parcels 45 a- d, Land Parcel 46 and the south-eastern corner of Land Parcel 45E fall within PQ-22a, which encompasses the main Mar Dyke Basin and is characterised by alluvium or Head clays, sands, and gravels on the valley floor, potentially a mixture of both with London Clay throughout. No known Palaeolithic remains have been discovered within this zone. Land Parcel 43 and the majority of Land Parcel 45E fall within PQ-24, which sit within the western side of the Mar Dyke basin, east of South Ockendon Hall. These land parcels consist of a spread of clay, sand and gravel Head deposits with occasional bedrock highs protruding through. Extensive clay quarrying has occurred to the south of Land Parcels 45E and 46 and has provided no indication of any unmapped Pleistocene terrace deposits or produced any Palaeolithic finds. The Palaeolithic potential has therefore been considered low to moderate for PQ-24, while the potential for PQ-22a is uncertain and requires further investigation, although the palaeoenvironmental potential is considered low for both PQ zones.

Holocene geoarchaeological background

General

- D.1.8 The route of the LTC crosses a tract of alluvium associated with the middle reaches of the Mar Dyke river immediately north-west of Orsett, Essex. Here the floodplain topography forms a large flat basin underlain by London Clay, previously occupied by Orsett and Bulphan Fens, mostly drained during the medieval period. The lower reaches in the vicinity of Stifford and Purfleet have been the subject of considerable geoarchaeological study, particularly the fossiliferous Pleistocene gravels associated with the ‘Ockendon meander’, a former course of the River Thames. There are areas of the scheme where Pleistocene deposits are likely to be exposed, for instance alongside the M25, and LTC has appointed a Palaeolithic specialist, Francis Wenban-Smith and geoarchaeologist Martin Bates, to provide a strategy for the investigation

and recording of these deposits where the scheme impacts upon them. This is discussed in the Palaeolithic and Quaternary Deposit Model (PQDM), and Preliminary Assessment of Archaeological Potential (Wenban-Smith and Bates 2020).

- D.1.9 The Mar Dyke valley floor alluvium (Holocene) was investigated during improvements to the A13 further downstream in the vicinity of North Stifford, where it reached over 5m in thickness (Wilkinson 1988). The sedimentary sequences at this location were complex, comprising intercalated freshwater peat and estuarine silt clay units dating back to the middle Holocene. Diatoms from the basal silts indicated estuarine conditions prevailed at this location, and a radiocarbon date of 4780-4380 cal BC (HAR 4522, 5740 ± 80 BP) from the top of this unit correlated it with Devoy's Thames II marine transgression (Devoy 1979). The lower wood peat, formed in freshwater alder carr, was correlated with Devoy's Tilbury III regression (ibid.) and provided pollen evidence for the early Neolithic elm decline. Evidence of human activity associated with the peat consisted of wood charcoal and a late Neolithic to early Bronze Age flint knife from the top of the unit. Later prehistoric burnt flint, pottery and charcoal was also recovered from the overlying sediments. Upper peat units were radiocarbon dated to the late Roman to Saxon periods, although altitudes diverged from the Devoy model, possibly due to local micro-topography of the valley floor (Wilkinson 1988, 106).
- D.1.10 In contrast, the sedimentary sequences associated with the middle reaches of the Mar Dyke have been subject to little geoarchaeological study. The current course of the Mar Dyke has been realigned and straightened and prior to the current project, the only borehole data available from the BGS online dates from the 1970s (the Mar Dyke Improvement Scheme) and consists of hand-written logs without overall interpretation. The descriptions in the boreholes vary with alluvial type deposits (silt and clay) noted at c 1.5 to >4.0m in thickness. In several locations the alluvium was described as peaty with laminations and waterlogged wood. Gravel was noted in the base of some of the sequences; where absent the presence of selenite or gypsum crystals may indicate tertiary bedrock, although the transition with the overlying alluvium is not always clear.
- D.1.11 The Mar Dyke was still tidal up to Stifford bridge in the eighteenth century and navigable to Orsett Hall and into the fens (Allison 1966, 11). While it is possible that it was tidal even further upstream earlier than this, it is more probable that the sequence of deposits in the middle reaches will be shallower and formed in differing depositional environments than the deep estuarine sequences recorded downstream towards the Thames confluence (Bates and Stafford 2013; Wilkinson 1988).
- D.1.12 The Holocene sedimentary sequences associated with the floodplain of the Mar Dyke where it is crossed by the Lower Thames Crossing scheme have the potential to preserve buried archaeological and palaeoenvironmental remains of significance. The current course of the Mar Dyke has been realigned and straightened, but clear evidence for former channels is visible on LiDAR data and further palaeochannels along with floodplain islands may lie buried at depth.

LTC Geotechnical and LiDAR data

- D.1.13 Examination of a tranche of recent LTC geotechnical and LiDAR data for the wider Mar Dyke valley was undertaken prior to the evaluation commencing which provided some additional information on the buried topography and the depth and character of

sedimentary sequences. The results have been outlined in detail in the WSI (OA 2021, fig. 4b).

D.1.14 In summary for Land Parcels 45A-E and 46, the majority of the geotechnical interventions across the area recorded "Head" deposits. Although some of these deposits in the upper part maybe associated with Holocene colluvium (ploughwash) and/or alluvium, the latter particularly in the lower lying eastern area adjacent to the current Mar Dyke in Land Parcels 45A, 45B and 45C. Overall, this indicated the Holocene sequences were likely to be relatively shallow, with the full depth likely to be exposed during trenching over much of this area. London Clay bedrock generally averaged 1-2m BGL. No organic deposits were noted in the geotechnical logs, however the LiDAR data faintly indicated a possible palaeochannel (former course of the Mar Dyke) meandering broadly north-south across Land Parcels 45B and 45C.

Method

Boreholes

D.1.15 The programme of purposive boreholes comprised the drilling of twelve boreholes in a transect (Transect 1, Figure 52) running west to east across Land Parcel 46 and NW-SE through Land Parcels 45D and 45C, to the west of the current Mar Dyke channel. The locations, elevations and total depths of the boreholes recorded are shown in Table 15.

D.1.16 The primary aim of the borehole survey was to investigate deposits at depth and to recover intact core samples. The boreholes were intended as contingency in the event difficult wet ground conditions precluded sampling from trench faces, or if deposits of interest extended below 2m BGL. Due to H&S, landowner and ecological restrictions, all borehole locations were preselected and could not be relocated between land parcels once fieldwork commenced.

Borehole	Easting	Northing	Elevation (m OD)	Total Depth (m)
OCA-WS101A	560904.753000	184065.819000	6.71	3.00
OCA-WS103	561003.479000	184067.616000	6.24	3.00
OCA-WS104A	561094.187000	184076.329000	5.80	3.00
OCA- WS106	561202.548000	184087.523000	5.24	3.00
OCA-WS107A	561305.102000	184097.389000	4.98	3.00
OCA-WS109	561527.247000	183957.662000	4.95	3.00
OCA-WS110A	561595.026000	183882.708000	5.03	3.00
OCA-WS112	561663.022000	183809.043000	4.62	4.00
OCA-WS113A	561730.513000	183734.519000	4.36	4.00
OCA-WS115	561798.444000	183660.999000	3.87	3.00
OCA-WS116A	561865.240000	183587.210000	3.59	3.00
OCA-WS118	561925.539000	183522.011000	3.67	3.00

Table 15: Summary of borehole locations

D.1.17 The borehole array was reviewed by the LTC geoarchaeologist with reference to opportunistic sampling of potential Pleistocene deposits. Taking this into account, secondary boreholes were drilled immediately adjacent to boreholes OCA-WS101, OCA-WS104, OCA-WS107, OCA-WS110, OCA-WS113 and OCA-WS116, the cores

to be retained unopened for potential OSL dating of minerogenic sequences should this be required. These cores were immediately wrapped in thick black plastic.

- D.1.18 The boreholes were drilled by Wheeler Site Investigation and Dynamic Sampling, under the supervision of an OA Geoarchaeologist, using a terrier type rig (windowless sampler). The rig can extract intact 1m long sleeved cores approximately 100mm wide. The boreholes were drilled until the upper levels of the London Clay bedrock had been reached, in order to enable the recovery of a complete sequence of deposits.
- D.1.19 Drilling locations were set out by an OCA Surveyor, and each location was CAT scanned prior to intrusive work commencing. Each borehole was cased to prevent collapse and to minimize contamination from deposits already drilled. On completion of the drilling, the boreholes were backfilled with bentonite pellets.

Trenches

- D.1.20 The trenches were excavated to a maximum 1m depth BGL in Land Parcels 43, 45E, 45D, as were most of the trenches in Land Parcel 46. The majority of trenches in Land Parcels 45C and 45B were investigated to a maximum of 2m depth BGL, or less where it was clear that Pleistocene deposits or the underlying bedrock geology had been reached. Machine excavation ceased at the first archaeological horizon if present within the trench.
- D.1.21 Sedimentary sequences from 44 trenches considered to be broadly representative were selected for geoarchaeological recording (46 section logs). These sequences are arranged into five transects (Transects 6-11, Figures 53-58, NB. Transects 2-5 form the borehole arrays in Land Parcels 47, 48A-H situated to the east of the current Mar Dyke channel and are reported on separately), illustrating the extent, depth, and complexity of the mapped Head and alluvial deposits, potential palaeochannel locations, recovered samples and associated archaeological finds/features.
- D.1.22 The recording of the sediments comprised the detailed geoarchaeological logging of one or more 1m wide sections in each of the selected trenches. Each section was allocated a section number and located relative to the National Grid and Ordnance Datum. Table 16 summarises the location, elevation and total depth of the sections recorded. The sediment sequences were recorded from ground surface on a geoarchaeological log proforma with each layer allocated a unique context number. Preliminary interpretations of associated depositional processes were also recorded on the logs.

Sediment recording and sampling

- D.1.23 Sediment recording followed Historic England guidelines (2015b) and Jones et al (1999), which typically included a description of texture, compaction, colour, clast size and abundance, bedding structures and other inclusions (e.g., charcoal), post-depositional features (e.g., rooting, mottling, mineralisation), and the nature of sediment contacts (e.g., abrupt, diffuse, irregular).

Trench	Section	Easting	Northing	Elevation (m OD)	Total Depth (m)
329	32900	560627.039000	184065.147000	8.80	0.46
335	33500	560855.424000	184129.431000	7.00	0.46
338	33800	560964.742000	184158.900000	6.20	0.70
341	34104	561511.182428	183952.281941	4.81	2.15
346	34600	561701.774144	183948.268402	4.42	0.52
353	35300	561668.101346	183913.646667	4.60	0.86
361	36100	561657.426098	183881.462548	4.64	1.51
362	36200	561701.253031	183867.260374	4.47	1.00
362	36300	561441.622397	183843.303742	5.64	0.44
366	36600	561557.288998	183839.613971	5.23	0.34
368	36800	561630.784000	183839.418000	4.80	0.39
370	37000	561712.692000	183840.186000	4.50	0.96
378	37800	561695.745855	183809.336269	4.26	0.92
381	38100	561665.472344	183779.573961	4.39	0.93
394	39400	562034.250367	183879.932629	4.17	1.73
397	39700	562005.316092	183790.330280	3.84	1.72
400	40000	561926.911094	183797.343827	3.55	1.68
403	40300	561987.868651	183726.574665	3.64	1.84
405	40500	561968.211915	183632.084830	3.69	1.79
406	40600	561840.082821	183806.376337	3.79	1.52
408	40800	561811.733607	183744.923431	4.18	1.38
411	41100	561691.079481	183710.396334	4.28	0.96
421	42100	561863.690640	183657.879187	3.83	1.72
423	42300	561817.141194	183643.428784	3.76	0.95
427	42701	561869.152511	183575.033805	3.56	1.72
430	43000	561834.998116	183549.740268	3.42	1.72
431	43100	561735.817214	183506.122431	3.37	1.78
433	43300	561838.264184	183493.261051	3.36	1.73
434	43400	561864.170118	183520.762525	3.33	1.94
435	43500	561894.027000	183530.893000	3.50	1.19
	43501	561907.850492	183531.213236	3.56	1.60
438	43800	561875.974648	183430.204448	3.64	1.60
440	44000	561786.926814	183369.035566	3.59	1.60
443	44301	561867.120146	183341.966217	3.47	0.82
445	44500	561919.240624	183368.405742	3.42	1.86
449	44900	561920.606228	183254.393848	4.19	1.52
450	45003	561978.612051	183272.341595	3.87	0.42
452	45205	562000.169821	183166.763711	4.71	0.54
454	45406	561986.992371	183053.205313	4.28	1.70
455	45504	562005.888029	183093.000039	4.51	1.90
456	45600	562004.706693	183022.917330	4.07	2.00
477	47700	561131.022000	184072.986000	5.11	1.05
	47701	561138.755957	184071.696333	5.24	1.75

Trench	Section	Easting	Northing	Elevation (m OD)	Total Depth (m)
495	49501	561179.413606	183874.877004	6.05	2.00
534	53401	560094.729000	183934.149000	20.86	0.23
541	54100	560282.691000	183934.485000	13.05	0.28

Table 16: Summary of geoarchaeology section locations

D.1.24 In addition to the recovered borehole cores, sampling of the sediment sequences was carried out in Trench 435 in accordance with Historic England guidelines (2011) and was targeted on a deeper and more complex alluvial sequence. Monoliths and OSL samples were taken from this sequence. Where sampling was carried out in a trench, the log proforma was accompanied by a measured section drawing marking the position of the samples. Sample details are presented in Table 17 below. The monoliths and OSL samples, along with the cores from the boreholes, have been retained should further work be required.

D.1.25 Following the completion of fieldwork, the lithological information from the logs (trench and boreholes) was inputted into geological modelling software (Rockworks 17) to allow the identification and broad correlation of a series of sediment facies. This enabled the creation of digital transects illustrating the key trench profiles across the site and the location of corresponding samples. A series of plates have been selected to illustrate the character of the sediment sequences described below (Plates 66-77) and the borehole core photos will be available in the site archive.

Trench	Sample	Sample type	Section	Context(s)
435	144	OSL	43501	43505
435	145	OSL	43501	43506
435	146	OSL	43501	43507
435	147	Monolith	43501	43500, 43501, 43502, 43503, 43504, 43505
435	148	Monolith	43501	43503, 43504, 43505, 43506, 43507
435	149	Monolith	43501	43507, 43508, 43509

Table 17: Summary of sampled sedimentary sequences

Results

D.1.26 Overall, several broad sediment facies were recorded across the site. The results are presented below and are discussed in relation a series of composite transects incorporating key trench/borehole sequences.

- **Topsoil** – modern ploughsoils
- **Subsoil** – modern clayey subsoils derived from underlying alluvium and Head deposits.
- **Alluvium** – Holocene overbank flooding deposits likely to have been deposited prior to the canalisation of the Mar Dyke River. Mid yellowish and greyish brown silty clays to clayey silts, often oxidised with rare clast content.
- **Stabilisation Horizons (organic)** – thin, wavy, dark yellowish brown clayey silt horizons with variable organic and humic content that are clear in places and ephemeral/diffuse in others. Poorly sorted and bioturbated containing limited clast content. Charcoal flecks present but rare, along with pale silty patches. Holocene in date, formed through pedogenic processes during stable dry periods with little or no flooding events occurring.

- **Leached Horizons** – firm but friable pale blueish grey to white fine silty deposits. Largely stoneless with frequent post-depositional weathering features (leaching, iron mineralisation, and rhizome calcretes) and evidence of bioturbation (rooting) from overlying deposits. Charcoal flecks were present albeit infrequent and worked flint artefacts recovered from these deposit. Possible leached subsoil horizon or alluvial deposit.
- **Channel Deposits** – laminated and cross-bedded silty clays with gravelly lenses. Mid yellowish, reddish and greyish brown Holocene deposits, fluvial in origin present in trenches corresponding to palaeochannel locations seen in LiDAR imagery.
- **Head Deposits** – heterogenous cold climate (Pleistocene) solifluction deposits comprising mottled light yellowish to mid reddish and greyish brown fine-grained silty clays with pale silty patches. Generally stone free, or with limited clast content. Frequent post-depositional weathering features including leaching and Fe mineralisation present
- **Weathered London Clay** - well sorted, fine-grained silty clay deposits. Dark yellowish to reddish brown in colour and lighter in colour than underlying London Clay bedrock. Generally stoneless with frequent post-depositional weathering features, such as iron mineralisation and calcite precipitation.
- **London Clay Bedrock**

Transect 1 – Borehole Transect

- D.1.27 Transect 1 (Figure 52) comprises the twelve primary boreholes and traverses Land Parcels 46, 45D and 45C. From OCA-WS101A, at the western extent of Land Parcel 46, it runs eastwards to OCA-WS107A where it then turns and runs south-east to OCA-WS109, through Land Parcel 45D, to OCA-WS118 in the south-eastern corner of Land Parcel 45C. Ground levels decrease from west of east over Land Parcel 46, from 6.71m OD at OCA-WS101A to 4.98m OD at OCA-WS107A. They also decrease from NW-SE over Land Parcels 45D and 45D, from 4.96m OD at OCA-WS109 to 3.59m OD at OCA-WS116A. Borehole OCA-WS110A is marginally higher (5.03m OD) than OCA-WS109, however the latter is located over a possible pond or quarry pit feature. Borehole OCA-WS-118 is also slightly higher (at 3.67m OD) than OCA-WS116A, which could be due to floodplain accretion, from the deposition of overbank alluvium, or related to palaeochannel action.
- D.1.28 Deposits identified within the majority of boreholes show a sequence of London Clay bedrock overlain by weathered units of London Clay, which are in turn overlain by light yellowish to mid reddish brown clayey Head deposits of varying thicknesses. The top of the London Clay bedrock was observed at 5.24m OD in OCA-WS103 and generally decreases in elevation to the east and south-east, to 1.47m OD at its lowest point in OCA-WS118. The top of the weathered London Clay deposits similarly decreases in elevation from west to east and south-east, from 5.81m OD (OCA-WS101A) to 2.01m OD (OCA-WS118), as do the overlying cold-climate (Pleistocene) Head deposits (6.33m OD at OCA-WS101A to 2.47m OD at OCA-WS118). This follows the slope of the dry valley in Land Parcel 46 and the eastward-facing lower slopes of the Mar Dyke basin.
- D.1.29 The predominance of Head deposits, and the notable absence of alluvium up to borehole OCA-WS116A, confirms the pattern indicated from the LiDAR and previous geotechnical data, i.e. the bedrock and Head extend as a lobe or promontory into the Mar Dyke basin. Away from palaeochannels, alluvial type deposits only appear

present immediately adjacent to the current Mar Dyke channel. A 0.23m thick pale greyish white fine silt deposit overlies the Head in borehole OCA-WS118, occurring at 2.7m OD. It is stoneless with iron mottling and appears to be a weathered deposit, possibly alluvial in origin or the remnants of a leached subsoil horizon. This is overlain by alluvial deposits, which are intercalated with two thin and ephemeral mid to dark greyish brown stabilisation horizons. The alluvium is described as mid grey to greyish brown, oxidised silty clay and occurs in two layers, at (2.97m OD and 3.25m OD and 0.27m and 0.18m thick respectively). The stabilisation horizons are not particularly organic/humic, occur at 3.07m OD and 3.29m OD and are 0.1m and 0.04m thick respectively. They indicate periods of a long enough hiatus in floodplain accretion for soil formation to begin and may have been partially eroded once alluviation recommenced. LiDAR imaging suggests a possible palaeochannel, a former meander of the Mar Dyke River, flowed south-west through the south-eastern corner of Land Parcel 45C. Both boreholes OCA-WS116A and OCA-WS118 are located on either side of this meander and no channel deposits were observed but were investigated in the trenches described below (eg. Trenches 400, 431, 434, 435, 440, 443, 445, Transects 3, 4, 5, 6 and 7).

Transect 6 – Trenches 534, 541, 329, 335 and 338

D.1.30 Transect 6 (Figure 53) is located at the head of the dry valley in Land Parcel 43 and extends longitudinally down the valley through Land Parcel 46, from west to east. Ground elevation is 20.86m OD at the highest point, Trench 534, and sharply slopes down to 6.2m OD in Trench 338 to the east. Deposits are shallow, with London Clay present at 20.64m OD and 12.78m OD in Trenches 534 and 541. A thin layer of weathered London Clay overlies the bedrock at this location and lies directly beneath the topsoil. Further down the valley, in Trenches 329, 335 and 338, Head deposits are present. These decrease in elevation eastwards, from 8.54m OD in Trench 529 to 5.74m OD in Trench 338. They occur directly beneath the topsoil in Trenches 529 and 335, and under a thin subsoil in Trench 338 (Plate 66). Head deposits are variable light yellowish brown to mid reddish brown clayey deposits that are largely stone free, although patches of gravelly pebbles were noted to occur within them. Archaeological activity was present on the upper slopes at the head of the dry valley. Two, undated, pits were identified within Trench 534 and occurred directly beneath the modern ploughsoil.

Transect 7 – Trenches 495, 363, 366, 368, 370, 406, 400 and 397

D.1.31 Transect 7 (Figure 54) is situated between the lower western slopes of the Mar Dyke basin, along a shallow valley promontory, and the current course of the Mar Dyke River. It is aligned NW-SE from the southern part of Land Parcel 46, crossing through the centre of Land Parcel 45D and extending into the floodplain over the northern part of Land Parcel 45C. Ground level decreases west to east, from 6.05m OD at Trench 495 (Section 49501) to 3.55m OD in Trench 400, though it rises slightly eastwards from Trench 400 to Trench 397 (to 3.84m OD). This could be due to floodplain accretion; however, LiDAR imagery shows possible palaeochannels in the north-eastern corner of Land Parcel 45C, suggesting the lower elevation in Trench 400 could be caused by a former channel of the Mar Dyke River.

D.1.32 London Clay bedrock was observed in Trenches 370, 400 and 406, decreasing in elevation eastwards between 3.72m OD in Trench 370 and 2.23m OD in Trench 400. Bedrock was not observed on the western slopes, although weathered London Clay was present in Trench 495 at 5.34m OD again decreasing in elevation eastwards to

2.44m OD in Trench 397 and seen to overlie London Clay in Trenches 370, 406 and 400.

- D.1.33 Variable yellowish brown clayey Head deposits overlie weathered London Clay and are particularly prevalent on the promontory slopes. Elevations vary from 5.73m OD in Trench 495, where they are 0.39m thick, to 4.28m OD towards the base of the slope (Trench 370) where they are 0.24m thick. Archaeological activity truncates the Head deposits on higher ground. An undated ditch ([37006]) is present beneath the modern ploughsoil in Trench 370.
- D.1.34 Head was also observed at 2.68m OD in Trench 397 where it is overlain by a 0.16m thick pale blueish grey leached horizon, the surface of which occurs at 2.84m OD (Plate 67). This horizon was also observed in Trenches 400 (at 2.8m OD, 0.07m thick, (Plate 68) and 406 (at 3.39m OD, 0.1m thick) and is noticeably silty, containing infrequent pebbles and charcoal as well as worked flint artefacts (e.g., context 40603). The pale colour of these deposits may be indicative of weathering and leaching typical of clay rich poorly draining geologies susceptible to shrink-swell behaviour (Smith 1989).
- D.1.35 The leached horizons are overlain by a sequence of intercalated thin, dark greyish brown stabilisation horizons and alluvial deposits. There are two stabilisation horizons in Trench 397 (Plate 67), one occurring at 2.9m OD (0.06m thick), which overlies the leached horizon and the other occurring at 3.06m OD (0.04m thick). They are humic in patches and more pronounced than those in Transect 6. A mid brownish grey silty clay alluvium separates these stabilisation horizons, which contains frequent iron mottling and thin planar laminations present to the upper 0.1m of the deposit. The laminations could indicate seasonal flooding events and the gradual stabilisation of the floodplain environment.
- D.1.36 In Trench 400, a mid brownish grey alluvium overlies the leached horizon (Plate 68). It exhibits less iron mottling than the alluvium in Trench 397, and the brownish colour is likely caused by staining from the organic material present within the overlying, humic-rich, stabilisation horizon. This horizon occurs at 3.03m OD, is 0.06m thick and forms a wavy, undulating layer within the sequence. In both Trenches 397 and 400, the upper stabilisation horizon is overlain by an oxidised, stone-free, silty clay alluvium. This occurs at 3.29m OD in Trench 400, where it is 0.26m thick, and 3.28m OD in Trench 397 (0.22m thick). The former is overlain by topsoil while the latter is overlain by a 0.24m deposit of mid brownish grey silty clay, present at 3.52m OD (context 39703). This deposit appears very similar in colour and composition to modern topsoil deposits and occurs at a similar elevation to the current land surface in Trench 400 (3.55m OD). It is overlain by a thin (0.1m thick) layer of oxidised alluvium that is directly overlain by modern topsoil, indicating overbank flooding has buried an older topsoil (context 39703). This may have occurred from the Mar Dyke River breaching its banks on its current, canalised, course or may be from a flooding event prior to the straightening of the Mar Dyke.

Transect 8 – Trenches 346, 353, 361, 362, 370, 378, 381, 411, 431 and 440

- D.1.37 Transect 8 (Figure 55) is located on the western fringes of the Mar Dyke floodplain, orientated north to south across the lower reaches of a low-lying promontory along the western Mar Dyke basin slopes on Land Parcel 45D and into the floodplain margins within Land Parcel 45C. Ground level is 4.42m OD at Trench 346, rising slightly to the south to 4.64m OD in Trench 361, and then gradually falling to 4.28m

OD at Trench 411 located further south. There is then a marked decline to the south of the promontory; 3.37m OD at Trench 431, rising slightly again to 3.59m OD at Trench 440 - both are located on the Mar Dyke floodplain. LiDAR images show a faint palaeochannel meander occurring in the vicinity of Trenches 431 and 440. The slightly higher elevation of Trench 438 (3.64m OD) shows higher ground between both loops of the meander, on the inside bank.

- D.1.38 Deposits on the shallow promontory invariably consist of London Clay bedrock overlain by weathered London Clay, which is then overlain by heterogeneous yellowish brown clayey Head deposits (Plate 69). London Clay occurs between 3.73m OD in Trench 361 and 3.53m OD in Trench 381, with Head deposits present at 4.39m OD in Trench 361 and 4.00m OD in Trench 411. Head deposits vary in thickness from 0.13m to 0.55m and were observed to be extensive throughout Land Parcel 45D. Archaeological activity was present in the form of undated pits and ditches that truncated the Head deposits. These occurred in Trenches 346, 362 and 378 and features were overlain by the modern ploughsoil.
- D.1.39 On the floodplain, London Clay bedrock was identified at 1.99m OD in Trench 431 and 2.11m OD in Trench 440 and was overlain by weathered London Clay deposits. These were covered by 0.26m of mottled, light yellowish brown clayey Head deposits in Trench 431 that exhibit post-depositional iron mineralisation and occurred at 2.65m OD. A silty, pale whiteish grey leached horizon overlies these Head deposits in Trench 431, occurring at 2.86m OD. This 0.21m thick deposit was generally stone free with occasional iron mottling and is likely to be either weathered alluvium or a leached subsoil horizon. A thin (0.09m thick) dark greyish brown stabilisation horizon, containing frequent organic material, was observed at 2.95m OD in Trench 431 and overlies the leached horizon (Plate 70). A thin (0.04m thick) possible stabilisation horizon is also present at 3.11m OD in Trench 440, although in contrast this is intercalated within alluvial deposits, very ephemeral, diffuse and discontinuous. The alluvium present in both Trenches 431 and 440 is oxidised, generally stone free, well sorted and comprised silty clay, with slightly greyer deposits in Trench 440. The top of the alluvium occurs at 3.05m OD in Trench 431 and 3.29m OD in Trench 440 and is overlain by modern ploughsoil.

Transect 9 – Trenches 406, 408, 421, 423, 427, 430, 433, 434, 438, 443 and 449

- D.1.40 Transect 9 (Figure 56) is aligned north to south through the Mar Dyke floodplain in Land Parcels 45C and 45B and crosses two palaeochannels indicated on the LiDAR. Ground elevations gently undulate from 3.79m OD in Trench 406 to 4.18m OD in Trench 408, and then fall to 3.33m OD in Trench 434. From here elevations rise slightly to 3.64m OD at Trench 438, fall briefly to 3.47m OD in Trench 443, before rising to 4.19m OD in Trench 449. The lower ground levels in Trenches 406, 427, 430, 433, 434 and 443 correspond with depressions identified in LiDAR imagery that indicate a former course of the Mar Dyke River, particularly a large meander that traverses south-west across the south-eastern corner of Land Parcel 45C which then turns south-east across the north-eastern part of Land Parcel 45B.
- D.1.41 Deposits consist of London Clay bedrock, observed in Trenches 406, 408, 421, 427, 340 and 449, the top of which undulates from 2.69m OD (Trench 406) to 3.07m OD (Trench 408), falling to 1.99m OD (Trench 430) and rising to 2.95m OD (Trench 449) further south. Weathered London Clay deposits overlie the bedrock, with similarly undulating elevations from 3.67m OD in Trench 449 to 1.71m OD in Trench 434.

- D.1.42 Variable, light yellowish brown Head deposits overlie the weathered London Clay in the trenches located on slightly higher ground (Trenches 408, 421, 423, 427 and 438), from 3.88m OD (Trench 408) to 2.78m OD.
- D.1.43 Possible channel deposits were identified at depth in Trenches 433 (Plate 71 and 434 (Plate 72), at 2.14m OD and 2.37m OD respectively, overlying weathered London Clay. These are mid yellowish, reddish and greyish brown clayey deposits that are laminated and exhibit bedding structures. In Trench 433, silty clay laminations are angled and appear to be dipping to the west. This 0.39m thick deposit is largely stone free, containing occasional patches of calcitic precipitations towards the top of the unit, with a 50mm thick band of calcareous material to the base. Contrastingly, the laminations present in Trench 434 are irregular and discontinuous sandy clays that appear to be cross-bedded with lenses of poorly sorted sub-rounded small gravelly pebbles (20-40mm). This possible channel deposit is 0.44m thick and overlain by a thin horizon of post-depositional iron mineralisation. Deposits in both 433 and 434 appear similar in colour to London Clay and weathered London Clay deposits, however the latter deposits were observed to be unstratified and relatively homogenous throughout the whole site. The laminations and cross-bedding present in the possible channel deposits in Trenches 433 and 434 are indicative of deposition within a fluvial environment.
- D.1.44 Firm, clayey heavily oxidised alluvial deposits overlie these channel deposits. These homogenous and unstratified deposits contain rare charcoal flecks and infrequent fibrous inclusions, with evidence of bioturbation. The top of these deposits occur at 2.56m OD (Trench 433) and 2.37m OD (Trench 434) and are 0.42m to 0.24m thick respectively. In Trench 433 (Plate 71) this alluvium is overlain by a 0.08m thick potential stabilisation horizon, comprising dark yellowish brown stoneless clayey silt with patches of bright white silt occurring towards the base from probably bioturbation. This horizon is not humic and no fibrous organic material was observed, although infrequent charcoal flecks were present. It may be post-depositional in origin and formed through illuviation / bioturbation.
- D.1.45 Silty, leached deposits are present in all trenches except Trenches 408 and 443, again showing topographical undulation ranging from 3.39m OD in Trench 406, 2.71m OD in Trench 434, to 3.75m OD in Trench 449. They overlie weathered London Clay and Head deposits in most trenches, and alluvium and possible stabilisation horizons in Trenches 434 and 433, varying in thickness from 0.08m in Trench 449 to 0.34m thick in Trench 434. Like the leached horizons seen in Transects 1, 7 and 8, they are generally stone free with infrequent charcoal flecks and iron mottling. The worked flint artefacts present in Trench 406 indicate a Holocene date for these deposits. They are likely to be either weathered alluvial deposits or leached remnant subsoils. The Head deposits present in Trench 408 contain pale silty patches similar to the sediments observed in leached horizons, however these appear as patches mixed within the light yellowish brown clayey silt. This could be a result of bioturbation or due to the leached deposits being less well developed. Trenches 406 (Plate 73) and 421 showed clearer versions of this sequence.
- D.1.46 Intercalated alluvium and stabilisation horizons overlie these leached horizons in trenches situated in the lowest parts of the transect and possible palaeochannel locations (Trenches 430, 434, 433 and 443). Stabilisation horizons occur at 3.07m OD in Trench 430, 2.89m OD and 3.07m OD in Trench 433 (Plate 71), 2.99m OD in Trench 434 (Plate 72), and 3.03m OD and 3.19m OD in Trench 443. They range

between 0.03m thick in Trench 433 to 0.06m thick in Trench 430 and consist of dark greyish and dark yellowish brown clayey silts often with frequent fibrous organic material. The uppermost horizons are clear and generally continuous, if wavy, and have been bioturbated through worm burrows and rooting. The lower horizons present in Trenches 433 and 443 are more ephemeral, discontinuous and diffuse with much lower organic content. Alluvium intercalated between and beneath the stabilisation horizons is largely stone free, homogenous and greyish brown, indicative of post-depositional staining from the movement of organic material down the sediment profile. Iron oxidation is common throughout these deposits and particularly prevalent in Trench 433 (context 43303). Alluvial deposits overlying stabilisation horizons are heavily oxidised and relatively thin, ranging from 0.04m thick in Trench 433 to 0.1m thick in 434, and occurred directly beneath the ploughsoil. Alluvium was also observed overlying leached deposits in Trenches 427 and 438, located beneath the ploughsoil at 3.16m OD and 3.93m OD respectively. These alluvial deposits are oxidised, although post-depositional staining from the movement of organic material was evident in their greyish brown appearance.

- D.1.47 Archaeological activity occurred on the floodplain margins and into the floodplain, though much less frequent than on the valley promontories. An undated pit in Trench 427 was identified at the base of the alluvial deposits, possibly truncating them, and a boundary ditch visible in OS maps was recorded in Trench 443. Middle Bronze Age pottery was recovered from a pit in Trench 409, located on the floodplain margins, that truncated Head deposits and was overlain by subsoil. The archaeological evidence suggests that the alluvium and stabilisation horizons are Holocene in date, with alluviation potentially occurring from the later prehistoric period onwards.

Transect 10 – Trenches 394, 397, 403, 405, 435, 445, 450, 452, 455, 454 and 456

- D.1.48 Transect 10 (Figure 57) is situated on the eastern boundary of Land Parcels 45C and 45B. It runs approximately north to south and is adjacent to the modern course of the Mar Dyke River. Ground levels are relatively flat in the northern half of the transect, falling gently from 4.17m OD in Trench 394 to 3.42m OD in Trench 445. From here they rise to 4.71m OD in Trench 452 before decreasing to 4.51m OD at Trench 456. Higher elevations to the southern part of the transect form the lower slopes of a shallow, narrow, east to west oriented promontory on the western slopes of the Mar Dyke basin as indicated on the LiDAR data.
- D.1.49 London Clay bedrock was identified at 1.96m OD in the northern part of the transect, in Trench 445, and is overlain by weathered London Clay deposits, the top of which occurs between 2.61m OD (Trench 394) and 2.2m OD (Trench 405). Bedrock was encountered much higher up in the southern part of the transect, between 3.51m OD (Trench 455) and 2.51m OD (Trench 456) and was also overlain by weathered London Clay deposits that were present between 4.43m OD (Trench 452) and 3.46m OD (Trench 356).
- D.1.50 Heterogenous light yellowish brown, mid reddish and greyish brown clayey Head deposits overlie weathered London Clay. The top of these deposits is seen between 2.94m OD (Trench 394) and 2.38m OD (Trench 445) in the northern part of the transect and between 4.49m OD (Trench 452) and 3.94m OD (Trench 454, Plate 75) on the higher ground to the south. These deposits are generally stone free and display post-depositional weathering features such as iron mineralisation that are particularly prevalent within trenches on the lower-lying floodplain areas. Archaeological activity was present on the higher ground and truncates the Head

deposits present in Trenches 452 and 454 (Plate 75). The activity comprised a concentration of ditches, pits and post-holes of later prehistoric date, potentially early Iron Age, and occurred directly beneath the ploughsoil. Possible prehistoric ditches were also identified in Trenches 450 and 455, truncating weathered London Clay deposits. These features are overlain by a thin, pale, alluvial deposit in Trench 450 and a thin, brownish grey subsoil in Trench 455. Both deposits are overlain by the modern ploughsoil.

- D.1.51 In the lower-lying areas in the north, the Head deposits were overlain by pale grey silty leached horizons. These occur between 3.25m OD (Trench 394) and 2.38m OD (Trench 445, Plate 76) and vary from 0.05m thick in Trench 403 to 0.31m thick in Trenches 394 and 435. A thin leached horizon is also present in the lower lying ground to the very south of Land Parcel 45B. Here it occurs at 3.57m OD and is 0.11m thick. As seen in previous transects, the deposits are generally stone free, bioturbated with infrequent iron mottling, fibrous organic material and charcoal flecks. They are likely to be either weathered alluvial deposits or leached remnant subsoils. These deposits are overlain by a sequence of intercalated alluvium and stabilisation horizons in the lowest-lying trenches (Trenches 397, 403, 405, 435 and 445) and a sequence of alluvial deposits in Trench 394. The lower alluvial deposits are homogenous, stoneless, oxidised greyish brown silty clays, between 0.06m thick (Trench 435) and 0.2m thick (Trenches 403 and 445). They occur between 3.47m OD (Trench 394) and 2.69m OD (Trench 405). The greyish brown colour is likely due to staining from post-depositional movement of organic material present in overlying deposits. Early Iron Age pottery was present in this lower alluvium in Trench 445 (Plate 76), giving these deposits a possible *terminus post quem* in the later prehistoric period. Stabilisation horizons occur at 2.9m OD and 3.06m OD in Trench 397, 2.09m OD in Trench 403, 2.76m OD in Trench 405, 2.96m OD and 3.28m OD in Trench 435 and 2.76m OD and 2.96m OD in Trench 445. They vary in thickness from 0.02m (Trench 445, Plate 76) to 0.07m (Trench 405) and are generally stoneless dark greyish brown clayey silts with a variable humic / fibrous organic content. The uppermost horizons are clearer, contain more organic material and are more continuous than the more ephemeral and diffuse lower horizons.
- D.1.52 Alluvium that overlies these stabilisation horizons consists of heavily oxidised, light yellowish brown silty clay deposits that are relatively stone free and homogenous. In Trenches 435 and 445 they occur directly below the modern ploughsoil at 3.4m OD and 3.14m OD respectively, whereas they appear deeper in the sedimentary sequence in Trenches 397 (3.00m OD), 403 (3.15m OD) and 405 (2.97m OD). The oxidised alluvium in these trenches is overlain by greyish brown silty clay deposits, humic in places with occasional fibrous organic material, stones, and chalk pebbles. These deposits are between 0.2m (Trench 403) and 0.3m thick (Trenches 394 and 405), occurring at 3.77m OD and 3.36m OD respectively. They are similar in appearance to the modern ploughsoils, which suggests they are remnant topsoils / ploughsoils that have been buried by alluvial deposits. The alluvium that overlies these deposits is between 0.1m (Trench 397) to 0.21m (Trenches 394 and 403) thick, oxidised silty clay that occurs directly below the modern ploughsoil. Alluvium also occurs beneath the topsoil in Trench 456, at the southern limit of Land Parcel 45B.

Transect 11 – Trenches 431, 433, 434, and 435

- D.1.53 Transect 11 (Figure 58) is located on the southern edge of Land Parcel 45C, running west to east traversing the potential palaeochannel meander observed from the

LiDAR imagery. Ground levels are relatively flat, ranging from 3.37m OD at Trench 431, falling slightly to 3.33m OD at Trench 434 before rising to 3.56m OD at Trench 435 (section 45301). From the LiDAR imagery, the course of the potential palaeochannel appears to run through Trenches 433 and 434, with Trenches 431 and 435 located on either bank. Lower elevations in these trenches support this observation.

- D.1.54 Deposits consist of London Clay bedrock, observed in Trench 431 at 1.99m OD overlain by weathered London Clay deposits present in all four trenches. The surface of this varies from 2.39m OD in Trench 431 to 1.72m OD in Trench 434, before rising to 2.4m OD in Trench 435 (section 43500).
- D.1.55 Variable light yellowish brown clayey Head deposits overlie the weathered London Clay in Trenches 431 and 435, occurring at 2.65m OD in the former and 2.48 - 2.6m OD in the latter and show signs of cryoturbation. Possible channel deposits, discussed in Transect 9, overlie the weathered London Clay in Trenches 433 and 434 (Plates 71 and 72) with the surface of these deposits at 2.14m OD and 2.13m OD respectively. These are overlain by alluvial deposits that are not dissimilar in appearance to the Head deposits identified in Trenches 431 and 435. These deposits occur at 2.56m OD in Trench 433 and 2.37m OD in Trench 434.
- D.1.56 Pale, silty leached horizons overlie the Head deposits in Trenches 431 and 435 and the alluvium in Trenches 433 and 434. The surface of these deposits occurs between 2.71m OD (Trench 434) and 2.91m (Trench 435, section 43500) and they vary in thickness between 0.13m and 0.34m. These deposits are bioturbated, relatively stone free, with infrequent charcoal flecks and iron mottling present and likely to be a weathered alluvium or a leached remnant subsoil. These leached horizons are then overlain by an intercalated sequence of alluvium and stabilisation horizons. The lower alluvium, occurring beneath stabilisation horizons, is present between 2.85m OD (Trenches 433 and 434) and 2.94m OD (Trench 435, section 43500). The stabilisation horizons were observed at 2.95m OD in Trench 431; 2.64m OD, 2.89m OD and 3.07m OD in Trench 433; 2.99m OD in Trench 434; 3.00m OD and 3.16m OD in Trench 435 (section 43500); and 2.96m OD and 3.28m OD in Trench 435 (Plate 77; section 43501, sampled). As discussed in previous transects, these horizons are thin, with the upper horizons forming clearer and more humic / organic horizons than the more ephemeral and diffuse lower horizons. Overlying the upper stabilisation horizons are oxidised alluvial deposits that are directly overlain by the modern ploughsoil.

Discussion and potential

- D.1.57 Geoarchaeological investigations undertaken throughout Land Parcels 43, 45A-E and 46 focussed on the sedimentary sequences of several key areas; the Mar Dyke floodplain, its floodplain margins, the lower slopes of shallow basin promontories and dry valley environments present on the western Mar Dyke valley slopes. The sequences are illustrated with seven composite transects (Figs 52-58), considered to be broadly representative of the correlated facies, but also latterly placed to coincide with those trenches containing intercalated archaeological remains. One of the main reasons for this was to illustrate the depth below ground level (BGL) and in metres Ordnance Datum (m OD) of key archaeological horizons that may be impacted by construction. Information from the finds assemblages and the position of recovered samples have also been added to the transects.

- D.1.58 The focus of the evaluation was mainly to determine the archaeological potential of the Holocene sequences. A further phase of purposive geoarchaeological field evaluation is planned to specifically to investigate the Palaeolithic/Pleistocene potential of the site. Where a depth of Pleistocene sediments was exposed, due to the undulating nature of the topography and/or to clarify the base of the Holocene sequence, the opportunity was taken to record and, in some cases sample, with monoliths and for OSL dating. This was done with the view to providing additional information prior to the later phase of planned purposive work. The basal geology of London Clay bedrock, mapped by the BGS, was identified in all land parcels and overlain by weathered London Clay deposits.
- D.1.59 Sediments within the dry valley (Transects 1, and 6 Figures 52-53) form shallow sequences where weathered London Clay and clayey Head deposits are directly overlain by modern ploughsoils. The Head deposits are likely to have formed through solifluction in cold-climate (Pleistocene) environments and are found only within the dry valley base and on the lower slopes, while the weathered London Clay occurs on the upper slopes. Little Holocene sedimentation appears to have taken place within the dry valley in the areas currently under investigation - deposits extend no deeper than 0.48m BGL and comprise modern ploughsoils and subsoils. Archaeological activity recorded throughout Land Parcels 43 and 46 identified features and artefacts ranging from late Bronze Age to early Iron Age (LBA/EIA) to Roman (R) in date, indicating multiple periods of activity have occurred throughout the Holocene with little sedimentation.
- D.1.60 Deposits on the valley promontories that extend into the Mar Dyke floodplain are similarly shallow, consisting of weathered London Clay overlain by soliflucted Head deposits (Transects 1, 7, 8, and 10 Figures 52, 54-55 and 57). This sequence is consistent throughout both the northern promontory, occurring over Land Parcels 45D and 46, and the southern promontory, located at the southern end of Land Parcel 45B. Edge alluvium was identified on the lower slopes of the southern promontory in Trenches 450 and 456 (Transect 10, Figure 57), although these deposits are relatively thin (< c 0.15m). The Holocene sequence here predominantly consists of modern ploughsoils, subsoils and thin alluvial deposits, showing a similar lack of sedimentation on the promontories as in the dry valley sequence. Archaeological activity also reflects this, with features and artefacts again ranging in date from LBA/EIA to RB occurring beneath modern ploughsoils, subsoils and thin alluvial deposits, truncating the underlying weathered London Clay and Head deposits. The range of dates likewise indicates that multiple periods of activity have occurred with little sedimentation or change in land surface. Archaeological activity appears to be concentrated on these promontories and areas of higher ground that sit slightly above the Mar Dyke floodplain, as little archaeology was observed within the floodplain itself.
- D.1.61 The sedimentary sequences moving onto the floodplain are more substantial and alluvial in nature than those on the promontories and in the dry valley, but still relatively peripheral to the main Mar Dyke basin ie. west of the current Mar Dyke channel in Land Parcel 48F-H; the potential channels identified on the LiDAR much less clearly defined.
- D.1.62 Transects 7, 8 and 10 (Figures 54-55 and 57) show the transition from the higher ground promontories into the floodplain and Transects 8 to 11 (Figures 55-58) show the variation within the floodplain itself. Basal deposits of London Clay and the

overlying weathered London Clay are still present, albeit at lower elevations, and cold-climate (Pleistocene) Head deposits overlie these deposits. Faint possible palaeochannels (former courses of the Mar Dyke River) can be seen meandering broadly north to south over the floodplain in LiDAR imagery. A large meander seen in LiDAR imagery traverses the southern part of Land Parcel 45C from NE-SW, through Trenches 433 and 434, before turning to head towards the south-east in the northern part of Land Parcel 45B. The course of the meander coincides with a dip in ground levels, with elevations in these trenches the lowest throughout site, at 3.36m OD and 3.33m OD respectively. Ground elevations remain low throughout the course of the meander in Land Parcel 45B (3.59m OD in Trench 440 and 3.42m OD in Trench 445). Possible palaeochannel deposits were identified overlying weathered London Clay deposits in Trenches 433 and 434 (Transects 9 and 11, Figures 56 and 58), although none were seen over the northern part of Land Parcel 45B (Trenches 440 and 445). The deposits in Trenches 433 and 434 are minerogenic and laminated, with cross-bedding occurring in Trench 434 containing gravelly. Head deposits are absent from Trenches 433 and 434, which suggests that these deposits have been eroded away by the potential palaeochannel. Although this will need further investigation, this evidence suggests that these could form palaeochannel deposits associated with a former course of the Mar Dyke River. The age of these deposits has not yet been determined; however, it is probable that this palaeochannel is of late Devensian - Holocene date as it is visible on LiDAR images and appears to truncate Pleistocene Head deposits. Unfortunately, no OSL samples were recovered from these very localised deposits due to an episode of excessive rain and deteriorating ground conditions limiting trench access and they did not appear in the borehole profiles.

- D.1.63 Other areas where possible palaeochannels were identified in LiDAR imagery include the northern part of Land Parcel 45C, corresponding with Trenches 397, 400 and 403 (Transects 7 and 10, Figures 54 and 57). Ground elevations are lower in these trenches, noticeably in Trench 400 (3.55m OD), but no laminated or cross-bedded sediments were present.
- D.1.64 The deposits overlying the channel deposits in Trenches 433 and 434 consist of mottled, oxidised silty clays that have been interpreted as alluvium formed through natural silting. Similar deposits, in Trenches 400, 440, 445 have been interpreted as weathered London Clay, while analogous deposits in Trench 435 are interpreted as Head. This highlights the difficulties in interpreting these clayey sediments on alluvial floodplains underlain by London Clay in various weathered forms.
- D.1.65 Pale, silty, leached horizons are encountered from the floodplain margins (Trenches 431 and 406) and extensively throughout the floodplain. These deposits are believed to be either weathered alluvium or remnant leached subsoil horizons. They largely occur at the base of the alluvial sequence and above Head deposits, perhaps indicating they may be late Glacial to early Holocene in date. If they are remnant leached subsoil horizons then it is possible they have been formed through podzolisation. Deposits underlying these horizons are orange in colour and exhibit the post-depositional iron mineralisation that occurs during the formation of podzols (Gerrard, 2000). There is a lack of redeposited organic material beneath the leached horizons which occurs in podzols, although this may indicate a relatively inorganic parent topsoil. The formation of podzols usually requires an acidic parent topsoil and contemporary podzols occur beneath coniferous forests (Gerrard, 2000). If these leached deposits are indeed remnant podzols it is possible that they were formed

under acid-rich topsoils, perhaps beneath coniferous forests, under relatively stable climatic conditions prior to the commencement of alluviation in the Mar Dyke floodplain. The absence of any further leached horizons further up the sediment profiles suggests that once alluviation began, conditions were no longer suitable for the formation of podzols.

- D.1.66 A sequence of intercalated oxidised alluvium and stabilisation horizons overlies the leached horizons on the floodplain and floodplain margins. These Holocene sequences are predictably thinner on the floodplain margins and thicker further into the floodplain. The stabilisation horizons are thin and discontinuous, with some trenches containing two or three horizons. The uppermost horizon is the most clear and distinct, with higher organic content, whereas the lower horizons are thinner, more diffuse and ephemeral with much lower organic content. These could represent periods of relative stability where flood events with alluviation were less widespread and/or less frequent (management?), reduced river flow or reduced sediment supply. Archaeological activity was less frequent within the floodplain and floodplain margins than on the areas of higher ground, consisting of pits ditches. The middle Bronze Age pottery recovered from a pit in Trench 409, on the floodplain margins, indicates the floodplain deposits are of Holocene age. The pit in Trench 427, although undated, is potentially prehistoric in date. It is located at the base of the alluvium and either truncates or is overlain by the leached horizon, suggesting that the alluviation of the Mar Dyke floodplain commenced from the prehistoric period onwards.
- D.1.67 In summary, the Holocene sequence throughout Land Parcels 43, 45A-E and 46 varies over three main zones. On the higher ground in the dry valley and on the shallow valley promontories the sequence is shallow and comprises modern topsoils, subsoils and thin alluvial layers with archaeological activity occurring beneath these. The sequence becomes thicker on the floodplain margins, consisting of leached horizons and alluvial deposits that overlie weathered London Clay and Pleistocene Head deposits. Further into the floodplain the sequence become deeper and more complex, comprising potential channel deposits, leached horizons overlain by intercalated alluvium and stabilisation horizons.
- D.1.68 One of the main purposes of this evaluation was to determine the geoarchaeological potential of the Holocene sequence present in the middle reaches of the Mar Dyke valley. Archaeological activity is concentrated on areas of higher ground, such as valley promontories that extend into the floodplain, and dry valleys which are present further up the valley slopes. However, activity has also been recorded further into the floodplain, occurring beneath and within alluvial sequences. The presence cut features at the base of the alluvium dates the onset of alluviation in the Mar Dyke valley at this particular location to at least the mid-later prehistoric Holocene period. The leached horizons that underlie the alluvial sequence form a key marker horizon and could denote the Pleistocene / Holocene boundary. Worked flints found within these deposits and the presence of charcoal indicate they are Holocene in date, and they appear to be truncated by prehistoric archaeological activity. This would place them as potentially late Glacial to early-Holocene sediments. Further work is recommended to date these deposits, as well as the overlying alluvium.
- D.1.69 No extensive organic waterlogged deposits were recorded, although thin, stabilisation horizons were intercalated within the upper part of the alluvial sequence. No archaeological activity was encountered in direct association with these, but it is possible they are related to historical drainage/management, latterly manifested by

the diversion of the river channel. More work will be required to establish a date for these deposits and to assess the preservation of a range of paleoenvironmental proxies (eg. pollen, WPR, diatoms, ostracods and OSL/radiocarbon dating), although better preserved and sampled sequences were recorded in Land Parcel 48.

Appendix E References

- Allison, R, 1966 *The changing landscape of south-west Essex from 1600 to 1850*, London, unpublished PhD thesis
- Atkinson, M and Preston, S J, (eds), 2015 'Heybridge: A Late Iron Age and Roman Settlement, Excavations at Elms Farm 1993-5' *Internet Archaeol.* **40** [REDACTED] (accessed 19th October 2021)
- Barclay, A, Booth, P, Knight, D, Evans, J, Brown, D H and Wood, I, 2016 *A Standard for Pottery Studies in Archaeology*, Historic England
- Bates, M and Stafford, E, 2013 *Thames Holocene: A Geoarchaeological Approach to the Investigation of the River Floodplain for High Speed 1, 1994-2003*, Oxford Wessex Archaeology Monograph
- Behrensmeyer, A K, 1978 Taphonomic and ecologic information from bone weathering, *Paleobiology* **4**, 150-162
- BGS 2021 *Geology of Britain Viewer*. Retrieved from [REDACTED] Viewed 18 November 2021
- Biddulph, E, Compton, J and Martin, T S, 2015 'The Late Iron Age and Roman Pottery' in M Atkinson and S J Preston (eds)
- Booth, P, 2019 Oxford Archaeology Roman pottery recording system: an introduction, unpublished
- Brown, N, 1999 The Archaeology of Ardleigh, Essex: Excavations 1955-1980, *East Anglian Archaeol.* **90**
- Brudenell, M, 2012 *Pots, practice and society: An investigation of patterns and variability in Post-Deverel Rimbury ceramic traditions of East Anglia* Unpublished, University of York PhD thesis
- Butler, C, 2005 *Prehistoric Flintwork*, Stroud, Tempus
- Chartered Institute for Archaeologists (CIfA), 2014a (Revised 2019) *Code of conduct: professional ethics in archaeology*
- Chartered Institute for Archaeologists (CIfA), 2014b (Revised 2019) *Standard and Guidance for Archaeological Evaluation*. Retrieved from [REDACTED]
- Chartered Institute for Archaeologists (CIFA), 2014c (Revised 2020) *Standard and Guidance for the Creation, Compilation, Transfer and Deposition of Archaeological Archives*.
- Clark, J, 1995 *The medieval horse and its equipment c1150-1450: medieval finds from excavations in London* Museum of London, London

- Cotter, J, 2000 *Post-Roman Pottery from Excavations in Colchester, 1971-85*, Colchester Archaeol. Rep. **7**. Colchester Archaeol. Trust
- Devoy, R J N, 1979 Flandrian sea level changes and vegetational history of the lower Thames estuary, *Philosophical Transactions of the Royal Society of London. B, Biological Sciences*, **285**, 355-407
- Drury, P J, 1978 *Excavations at Little Waltham 1970–71*, York, CBA Research Report No **26**, Chelmsford Excavation Committee Report **1**
- Gerrard, J, 2000 *Fundamentals of Soils*, Routledge, London
- Going, C J, 1987 *The Mansio and other sites in the south-eastern sector of Caesaromagus: the Roman pottery* Counc. Brit Archaeol. Res. Rep **62**
- Highways England, 2018 *Lower Thames Crossing: A Scheme Wide Specification for Archaeological Trial Trenching: unpublished document HE540039-CJV-GEN-GEN-SPE-HER-00001draft, Revision 1.05*
- Historic England, 2011 *Environmental Archaeology: A Guide to the Theory and Practice of Methods, from Sampling and Recovery to Post-excavation*
- Historic England, 2015a *Management of Research Projects in the Historic Environment: The MoRPHE Project Managers' Guide*, Swindon: Centre for Archaeology Guidelines
- Historic England, 2015b *Geoarchaeology: Using an earth sciences approach to understand the archaeological record*
- Jones, A P, Tucker, M E, and Hart, J K, 1999 Guidelines and Recommendations, in *The description and analysis of Quaternary stratigraphic field sections, Technical Guide No. 7* (eds A P Jones, M E Tucker and J K Hart), Quaternary Research Association: London, 27-76
- Magnitude Surveys, 2020 *Geophysical Survey Report of Lower Thames Crossing Essex*
- Major, H J, 1999 'Fired Clay' in Brown 1999, 157-8
- McKinley, J I, 1989 Cremations: expectations, methodologies and realities, in C Roberts, F Lee and J Bintliff (eds) *Burial Archaeology – Current Research, Methods and Developments*, BAR Report **211**, Oxford
- McKinley, J, 2000 'The analysis of cremated bone', in Cox, M. and Mays, S. (eds) 2000 *Human Osteology in Archaeology and Forensic Science*, London, Greenwich Medical Media
- McKinley, J I, 2004 Compiling a skeletal inventory: cremated human bone, in: M Brickley and J I McKinley (eds.), *Guidelines to the Standards for Recording Human Remains*, IFA Paper No. **7**, BABAO and IFA: Southampton and Reading: 9-13
- McKinley, J I, 2006 Cremation...the cheap option? In C Knusel and R Gowland (eds) *The Social Archaeology of Funerary Remains*, Oxbow Books, Oxford: 81-8.

- McKinley, J I, 2013 Cremation: excavation and analysis. In S Tarlow and L Nilsson Stutz (eds) *The Oxford Handbook of the Archaeology of Death and Burial*, 147-72, Oxford, Oxford University Press
- Medlycott, M (ed.), 2011 *Research and Archaeology Revisited: A Revised Framework for the East of England*, East Anglian Archaeology Occasional Paper **24**: Association of Local Government Archaeological Officers
- MPRG, 1998, *A Guide to the Classification of Medieval Ceramic Forms*, Medieval Pottery Research Group Occasional Paper 1
- Oxford Archaeology, 2019a Lower Thames Crossing Scheme-wide Written Scheme of Investigation for Trial Trenching south of the River Thames, unpublished document HE540039-BAL-GEN-GEN-REP-HER-00001
- Oxford Archaeology, 2019b *Lower Thames Crossing Scheme-wide Written Scheme of Investigation for Trial Trenching north of the River Thames*, unpublished document HE540039-BAL-GEN-GEN-REP-HER-00002
- Oxford Archaeology, 2021 Lower Thames Crossing: Detailed Written Scheme of Investigation P for Trial Trenching of Land Parcels 43, 45-48, 120-12, unpublished document HE540039-BAL-GEN-GEN-REP-HER-00051
- Oxford Cotswold Archaeology, 2020a Lower Thames Crossing: Archaeological Evaluation report for Trial Trenching of Land Parcel 22, Whitfield South Scheduled Monument Complex, South of Stifford Clays Road, Baker Street, Essex, unpublished document HE540039-CJV-GEN-GEN-REP-GEO-00026
- Oxford Cotswold Archaeology, 2020b Lower Thames Crossing: Archaeological Evaluation report for Trial Trenching of Land Parcel 21, Whitfield, North of Stifford Clays Road, Baker Street, Essex, unpublished document HE540039-BAL-GEN-GEN-REP-HER-00027
- Oxford Cotswold Archaeology, 2021a Lower Thames Crossing: Archaeological Evaluation report for Trial Trenching of Land Parcels 48B and 48C, Mar Dyke Valley, between South Ockendon and Orsett, unpublished document HE540039 BAL-GEN-GEN-REP-HER-00041
- Oxford Cotswold Archaeology 2021b Lower Thames Crossing: Archaeological Evaluation report for Trial Trenching of Land Parcels 54 and 126 Land North of North Ockendon, Havering, unpublished document HE540039-BAL-GEN-GEN-REP-HER-00040
- Oxford Cotswold Archaeology forthcoming, 2022 Lower Thames Crossing: Archaeological Evaluation report for Trial Trenching of Land Parcels 48F, 48G and 48H, Mar Dyke Valley, between South Ockendon and Orsett, unpublished document HE540039 BAL-GEN-GEN-REP-HER-00063
- Place Services, 2019 *Lower Thames Crossing Aerial Investigation and Mapping Report*, Essex County Council.

- PCRG, 2010 *Prehistoric Ceramics Research Group guidelines Occasional Papers 1 and 2*
- Smith, A, 1989 Geology of the Stanford-le-Hope district (1:10,000 sheet TQ68SE; parts of 1:50,000 sheets 257, Romford & 258/259, Southend & Foulness), British Geological Survey, Technical Report No. WA/89/40
- Tyrell, R, 2015 'Ceramic loomweights' in Atkinson and Preston (eds) 2015
- Webster, P, 1996 *Roman Samian pottery in Britain*, Practical Handbook in Archaeology **13**, Council for British Archaeology, York
- Wenban-Smith, F, and Bates, M, 2020, Lower Thames Crossing, Palaeolithic and Quaternary Deposit Model (PQDM), and Preliminary Assessment of Archaeological Potential, unpublished report prepared for LTC (Lower Thames Crossing)
- Wilkinson, T, 1988, *Archaeology and environment in South Essex: Rescue archaeology along the Grays by-pass 1979-80*, East Anglian Archaeol Rep 42

Appendix F Abbreviations and Glossary

ADS Archaeology Data Service. Digital archaeological archive

CDM Construction Design Manual. Health and safety guidance for the construction industry

CPD Continuing Professional Development

CIfA Chartered Institute for Archaeologists

DBA Desk Based Assessment. Detailed assessment of archaeology and other aspects of the historic environment

DCO Development Consent Order

EIA Environmental Impact Assessment. Detailed study of environmental impacts as directed under The Town and Country Planning (Environmental Impact Assessment) Regulations 2017 following on from EU Directive EIA Directive (85/337/EEC)

ES Environmental Statement. The principal environmental report detailing environmental impacts within an EIA

GPS Global Positioning System

HER Historic Environment Record

LTC Lower Thames Crossing

MCIfA Member of the Chartered Institute for Archaeologists

MoRPHE Management of Research Projects in the Historic Environment

NMP National Mapping Programme. A study of aerial photographs and digitisation of resulting data into GIS. Originally funded by Historic England

OASIS Online Access to the Index of archaeological investigations.
The OASIS project brings together a number of strategic partners: the Archaeology Data Service, Historic England, Historic Environment Scotland, and the Royal Commission on the Ancient and Historical Monuments of Wales under the umbrella of the University of York

OCN Old County Number. Historic England's reference for material that is not readily-available online and may represent historic archaeological work that consists of paper archives or has yet to be formally reported on

PINS Planning Inspectorate

RAMS Risk Assessment Method Statement

SMC Scheduled monument consent

TDR Trusted Digital Repository

UKIC United Kingdom Institute for Conservation

WSI Written Project of Investigation. A detailed method statement for archaeological work

WSL – Western Southern Link
The Western Southern Link (WSL) is an alternative for Short List Routes 2, 3 and 4 to the south of the River Thames.

Appendix G Site Summary

Site name:	Lower Thames Crossing, Land Parcels 43, 45A-E and 46 Mar Dyke Valley, between South Ockendon and Orsett
Site code:	LTC43M21
Grid Reference	Centred on NGR 561994 183659
Type:	Evaluation
Date and duration:	Seven weeks, from 9th September – 29th October 2021
Area of Site	c. 104.5ha

Location of archive:

The archive from Land Parcels 43, 45A-E and 46 will form part of the overall trial trenching scheme archive. This will be deposited in a repository consistent with the standards required by the Museums and Galleries Commission following completion of the archaeological phase of this project. This may either be with the local receiving museum in Thurrock or, if no such repositories are available, with a repository for the whole project designated by LTC. LTC retain the overall responsibility for the successful deposition of the project archive.

Currently, the archive is held at Oxford Archaeology's head office, Janus House, Osney Mead, Oxford, Oxfordshire, OX2 0ES. Oxford Archaeology will store the archive for LTC for a maximum period of 2 years following the completion of the project. If arrangements for the deposition of the archive have not been completed by this time, an extension to the storage period and final deposition timetable will be reviewed by OA and LTC and agreed with the Key Archaeological Stakeholders.

Summary of Results:

Oxford Cotswold Archaeology was commissioned by Balfour Beatty to undertake a trial trench evaluation of Land Parcels 43, 45A-E and 46 of the Lower Thames Crossing Pre-Enabling Works. Land Parcels 43, 45A-E and 46 are located c 1km to the south-east of the village of North Ockendon and c 2.5km north-east of South Ockendon in the historic parish of South Ockendon in Thurrock unitary authority, within the county of Essex (broadly centred on NGR 561994 183659). The evaluation comprised the excavation of 240 trenches and was completed between 9th September to 29th October 2021.

Archaeological features were reasonably well defined against the underlying London Clay and Head deposits, especially since the majority cut through the Head deposits rather than directly through the London Clay. Several natural features were also excavated to clarify whether they were of geological or archaeological origin. Wet weather was increasingly a problem towards the end of the evaluation, but had a limited impact since archaeological remains were identified during initial stripping and were predominantly evaluated prior to flooding. A total of 67 trenches revealed archaeological features.

Alluvial deposits were widespread across the floodplain and floodplain margins in Land Parcels 45B and 45C, and in one trench on the edge of 45D. Archaeological remains were found beneath alluvium in Land Parcels 45B and in 45D. In Land Parcel 45C Iron Age finds came from an alluvial layer, possibly indicating surface activity.

With the exception of a very small residual flint assemblage no activity of earlier prehistoric date was recorded within the site. A pit containing much of a single middle Bronze Age vessel, struck flints, charcoal and charred grain was found in Land Parcel 45C. This was the only feature of this date identified.

A focus of late Bronze Age or early Iron Age activity was found in Land Parcel 46, centred on a ditch containing pottery, a flint core and flakes, part of a cremated human burial, fired clay and charcoal, with a possible hearth pit adjacent, both cut into a possible occupation layer. Similar finds were also recovered from adjacent trenches.

Several small areas of Iron Age activity were identified across the site, all at the edges of the evaluated area, so possibly adjacent to more substantial activity areas. Two areas, one in Land Parcel 45B, the other in 45E, contained groups of postholes and other features associated with Iron Age pottery and fired clay objects suggesting either domestic or agricultural structures. Others in Land Parcels 43, 45B and 45D had finds predominantly in parallel ditches, possibly indicating paddocks or cultivation trenches.

In the late Iron Age and Roman periods finds came predominantly from U-profiled cultivation trenches that occurred in patchy concentrations across the valley sides, though not all contained pottery. These are similar to others found on the southern slope of the Mar Dyke valley and in a tributary valley to the north-west, and represent a widespread local type in the Roman cultivation of the slopes of the Mar Dyke valley

A small but substantial cropmark rectangular enclosure in Land Parcel 45D was confirmed as medieval, the pottery assemblage indicating use from at least the 13th century to the 15th century. Post-medieval field boundaries corresponding with those depicted on historic maps and evident as cropmarks were recorded were identified in Land Parcels 43 and 45B.

\\10.0.10.86\Projects\Lower_Thames_Crossing\010\Geomatics\03 GIS Projects - LTC43M21\Figures\LTC43M21_NORTH_1_Report_Fig1.mxd\caroline.souday\21/12/2021

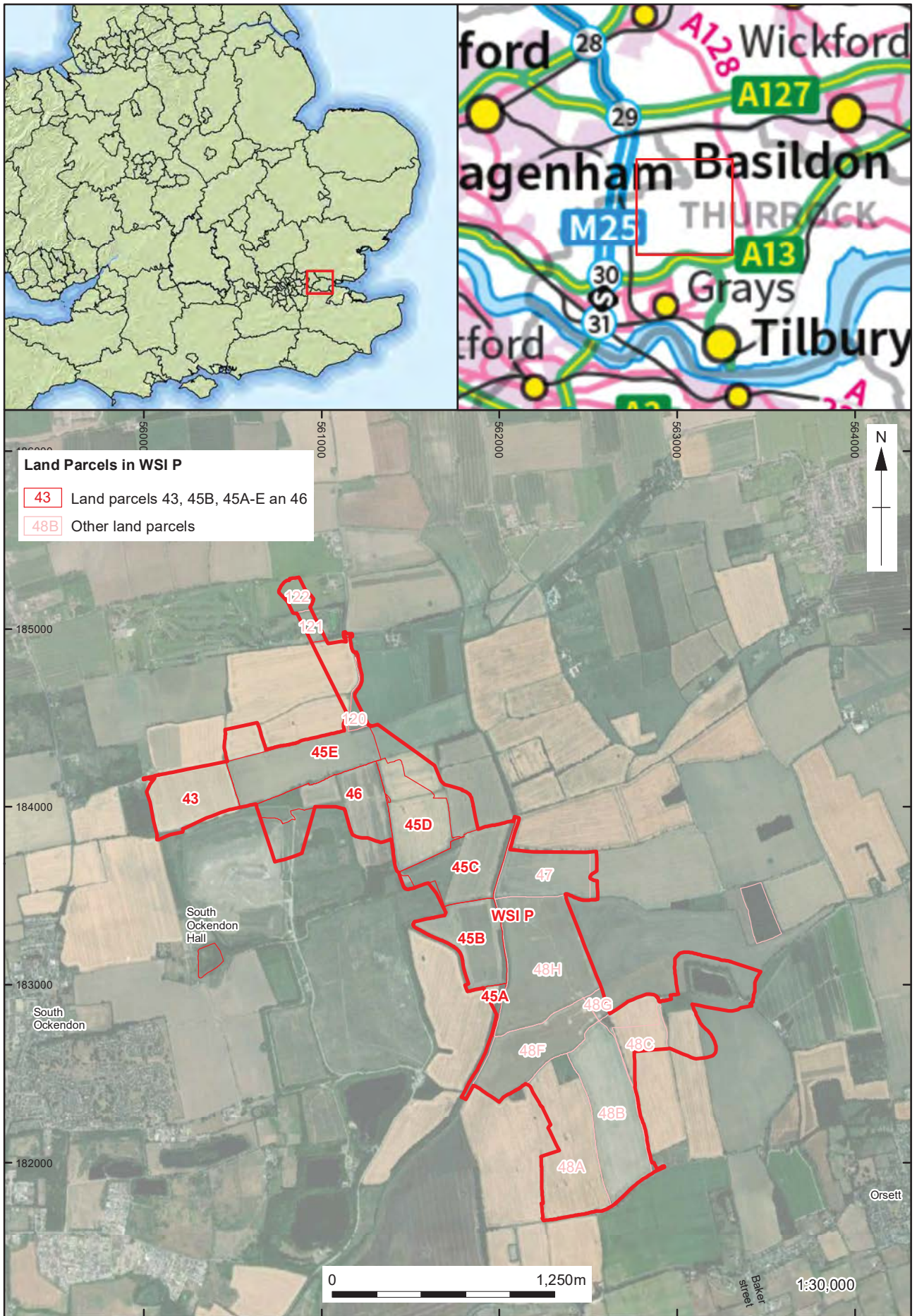

Source: Esri, Maxar, GeoEye, Earthstar Geographics, CNES/Airbus DS, USDA, USGS, AeroGRID, IGN, and the GIS User Community
Contains Ordnance Survey data © Crown copyright and database right 2016

Figure 1: Map showing the location of Land Parcels 43, 45A-E and 46

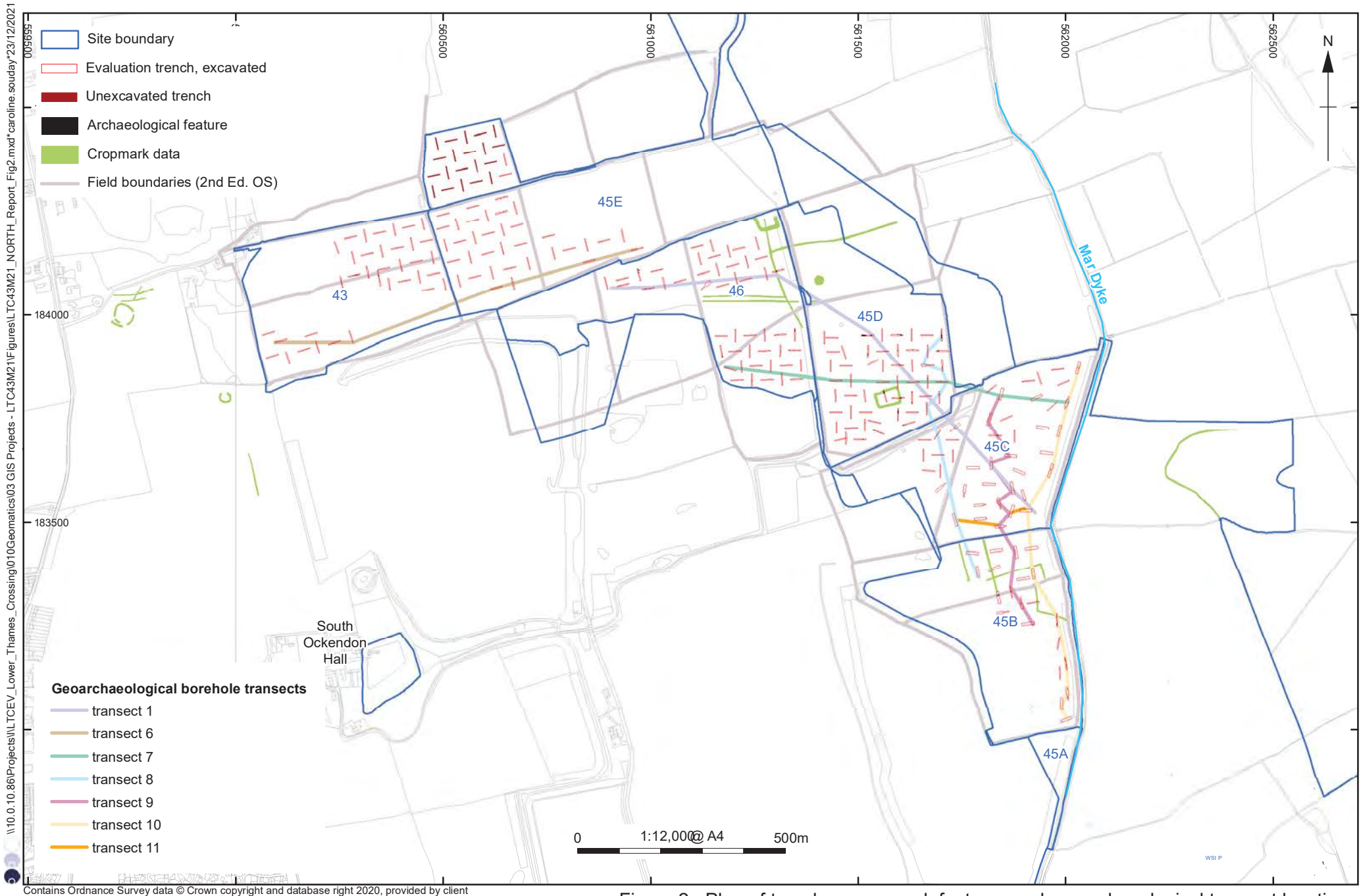
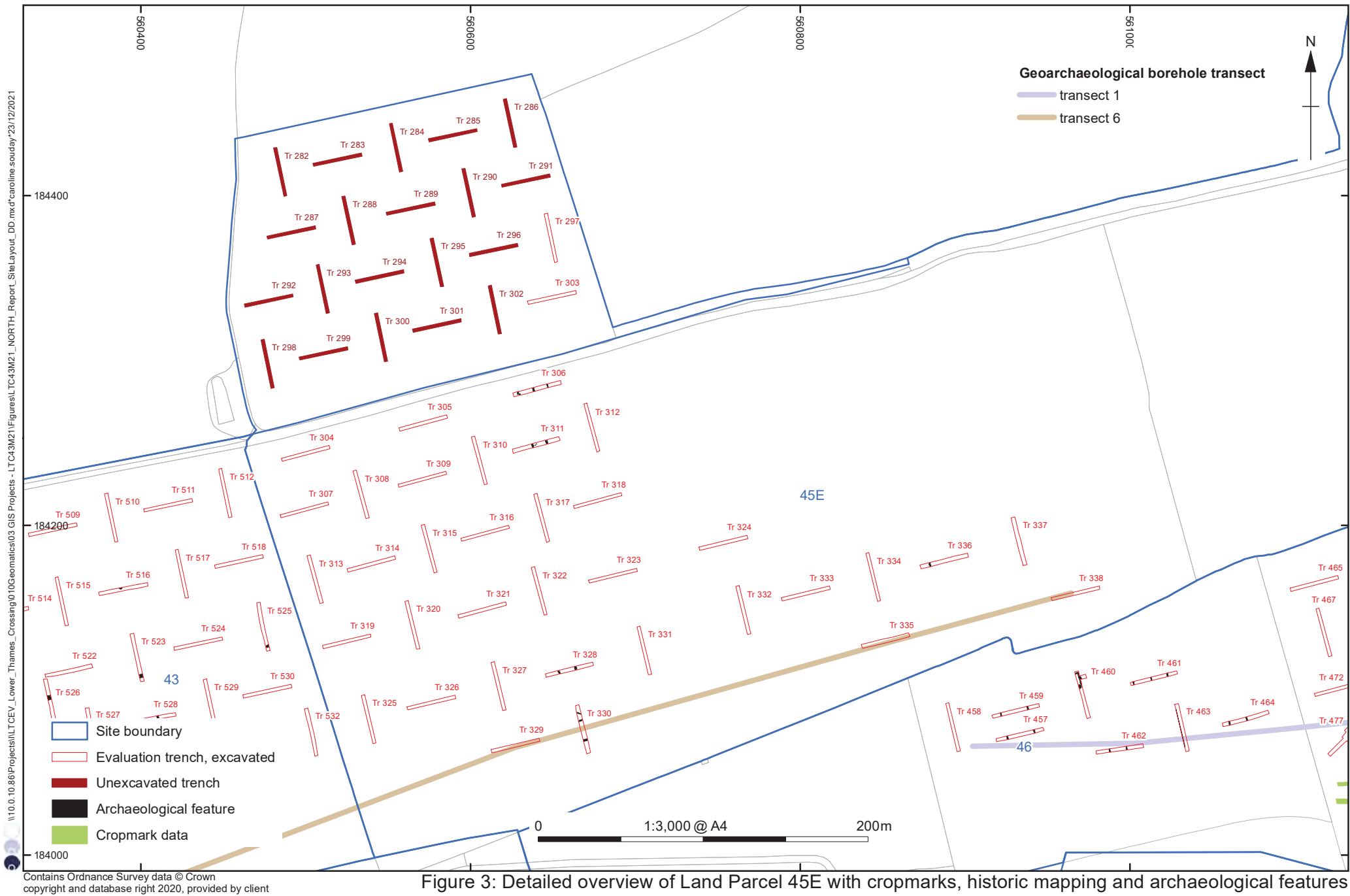
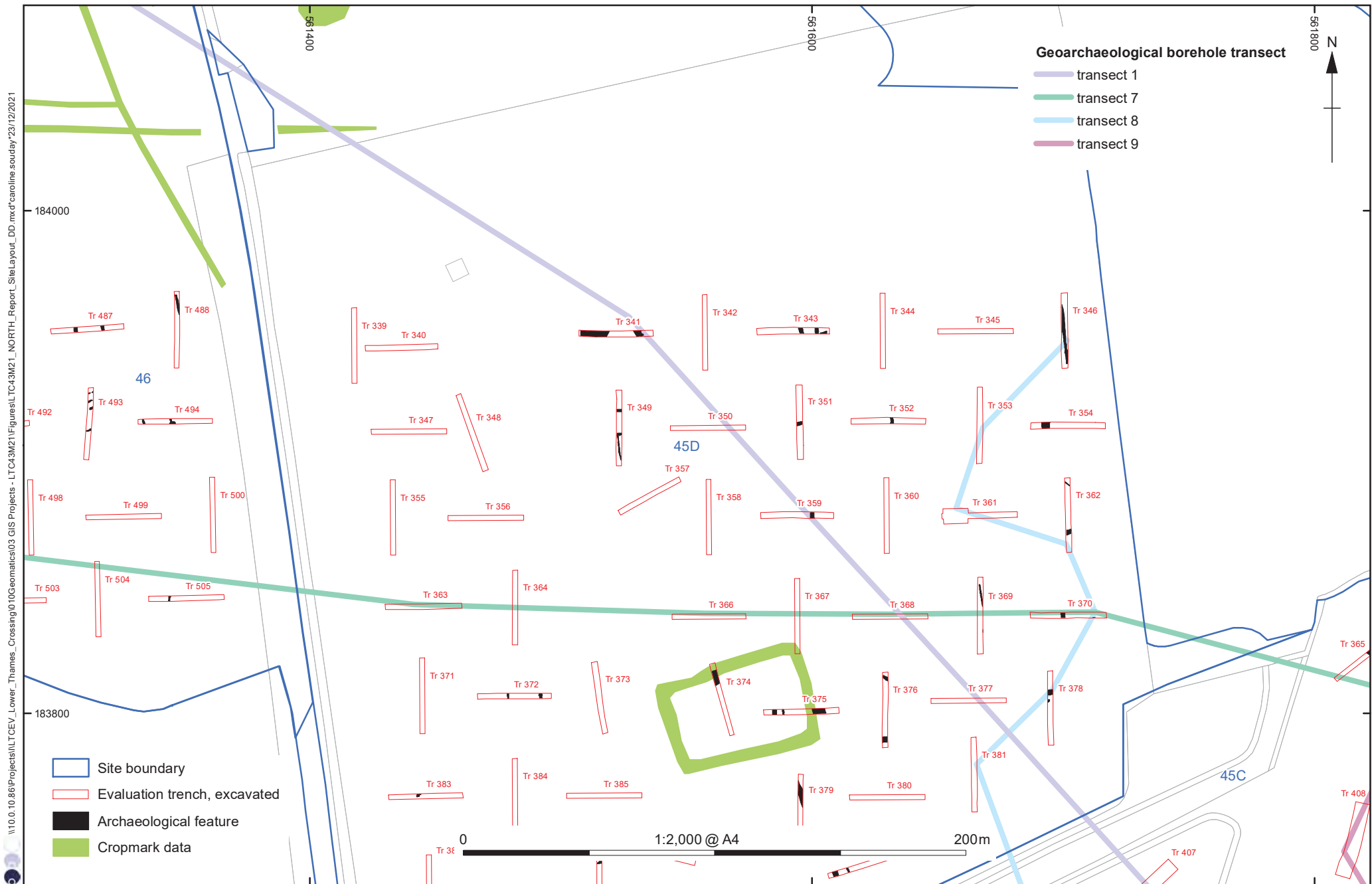

Figure 2 : Plan of trenches, cropmark features and georarchaeological transect locations



\\10.0.10.86\Projects\ITCEV_Lower_Thames_Crossing\010\Geoemetrics\03 GIS Projects - LTC43M21\Figures\LTC43M21_NORTH_ReportL_SiteLayout_DD.mxd\caroline.souday\23/12/2021

Contains Ordnance Survey data © Crown copyright and database right 2020, provided by client



\\10.0.10.86\Projects\LTCEV_Lower_Thames_Crossing\010\Geomatics\03 GIS Projects - LTC43M21\Figures\TLC43M21_NORTH_Report_L_SiteLayout_DD.mxd\caroline.soudry\23/12/2021

Contains Ordnance Survey data © Crown copyright and database right 2020, provided by client

Figure 4: Detailed overview of north half of Land Parcel 45D with cropmarks, historic mapping and archaeological features

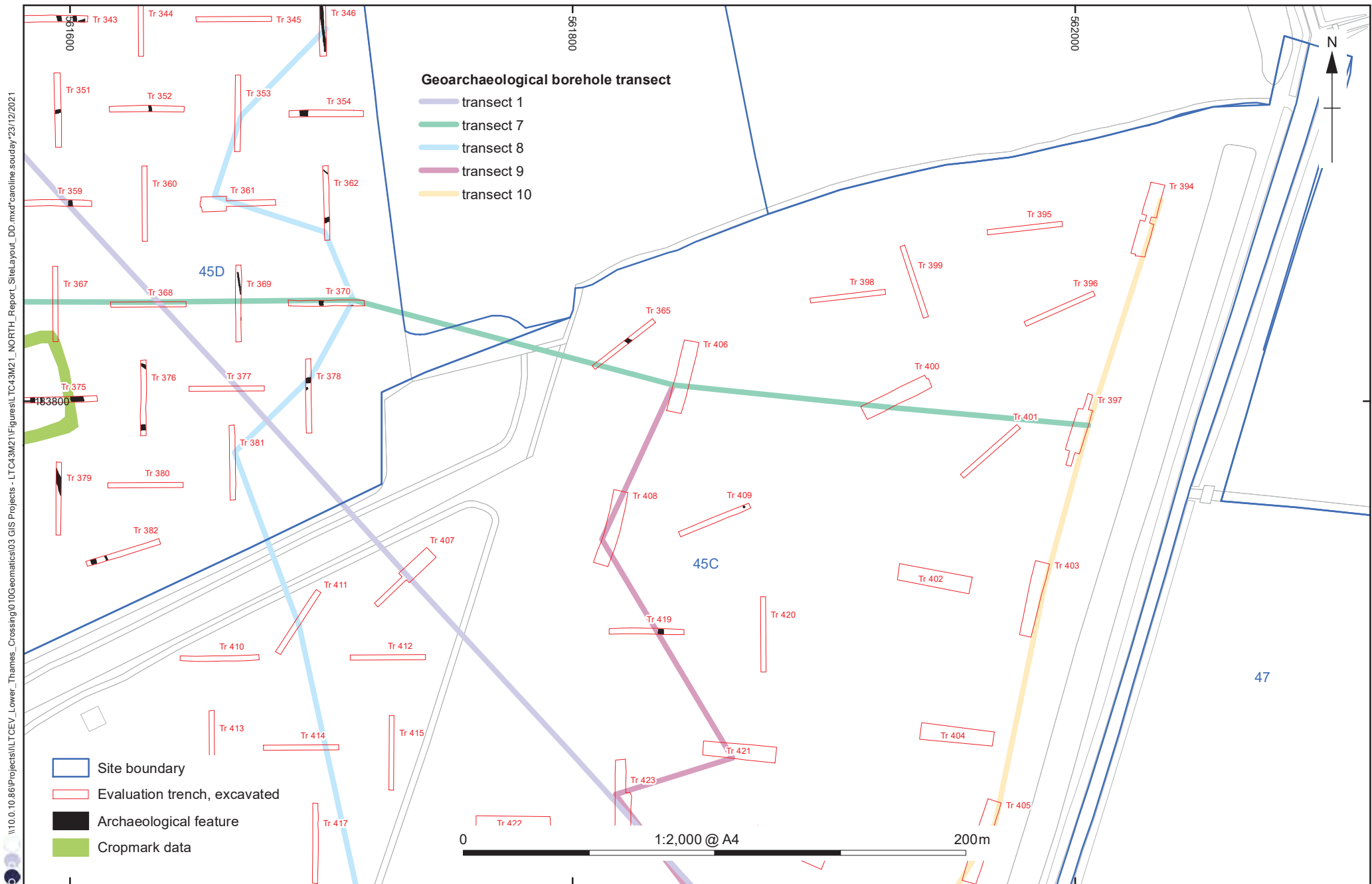

Contains Ordnance Survey data © Crown copyright and database right 2020, provided by client

Figure 6: Detailed overview of north half of Land Parcel 45C with cropmarks, historic mapping and archaeological features

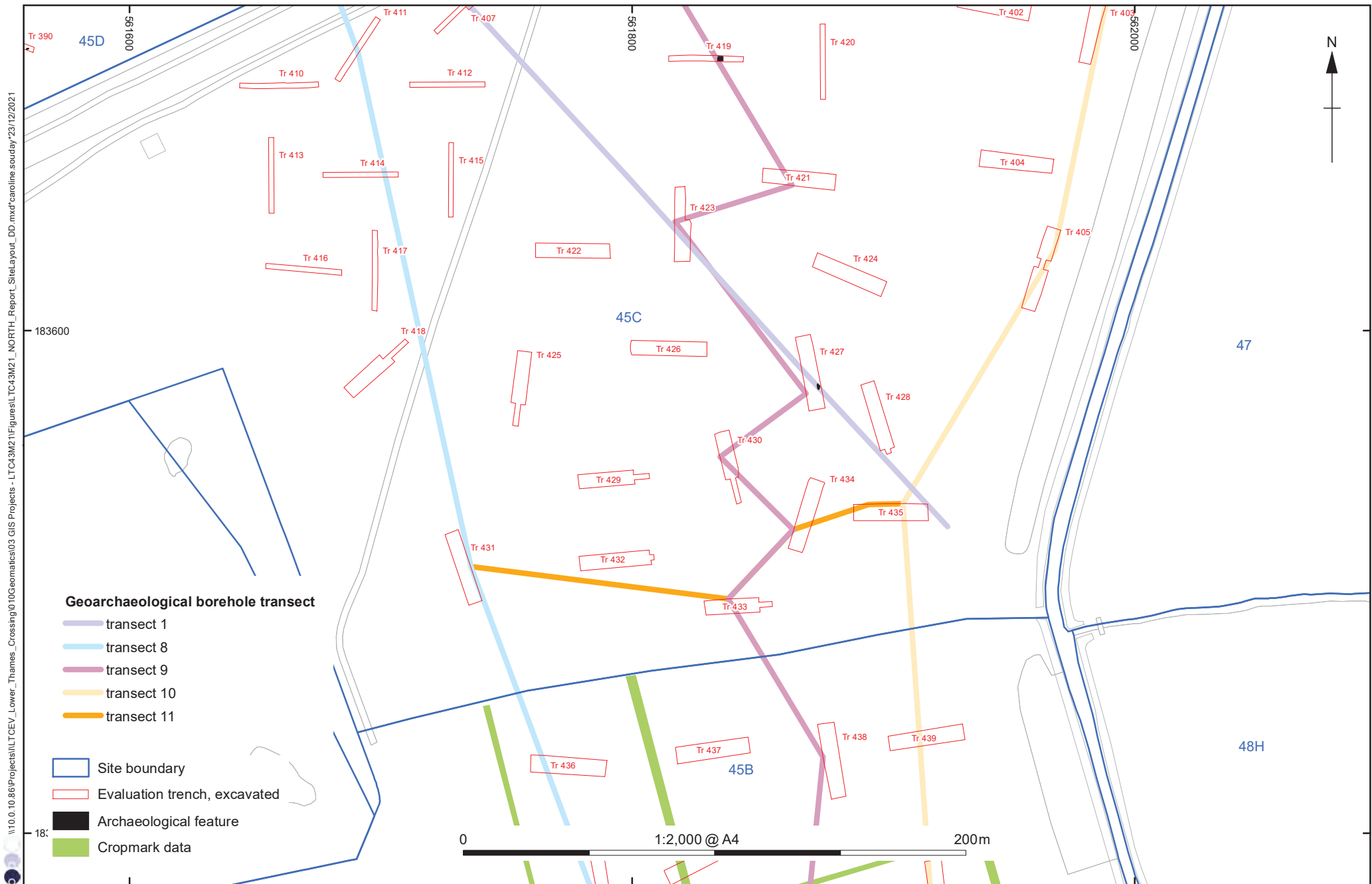

\\10.0.10.86\Projects\ILTCEV_Lower_Thames_Crossing\10\Geoemates\03 GIS Projects - LTC43M2\1\Figures\LTC43M2_1_NORTH_Report_L_SiteLayout_DD.mxd\caroline.soudey\23/12/2021

Contains Ordnance Survey data © Crown copyright and database right 2020, provided by client

Figure 7: Detailed overview of south half of Land Parcel 45C with cropmarks, historic mapping and archaeological features

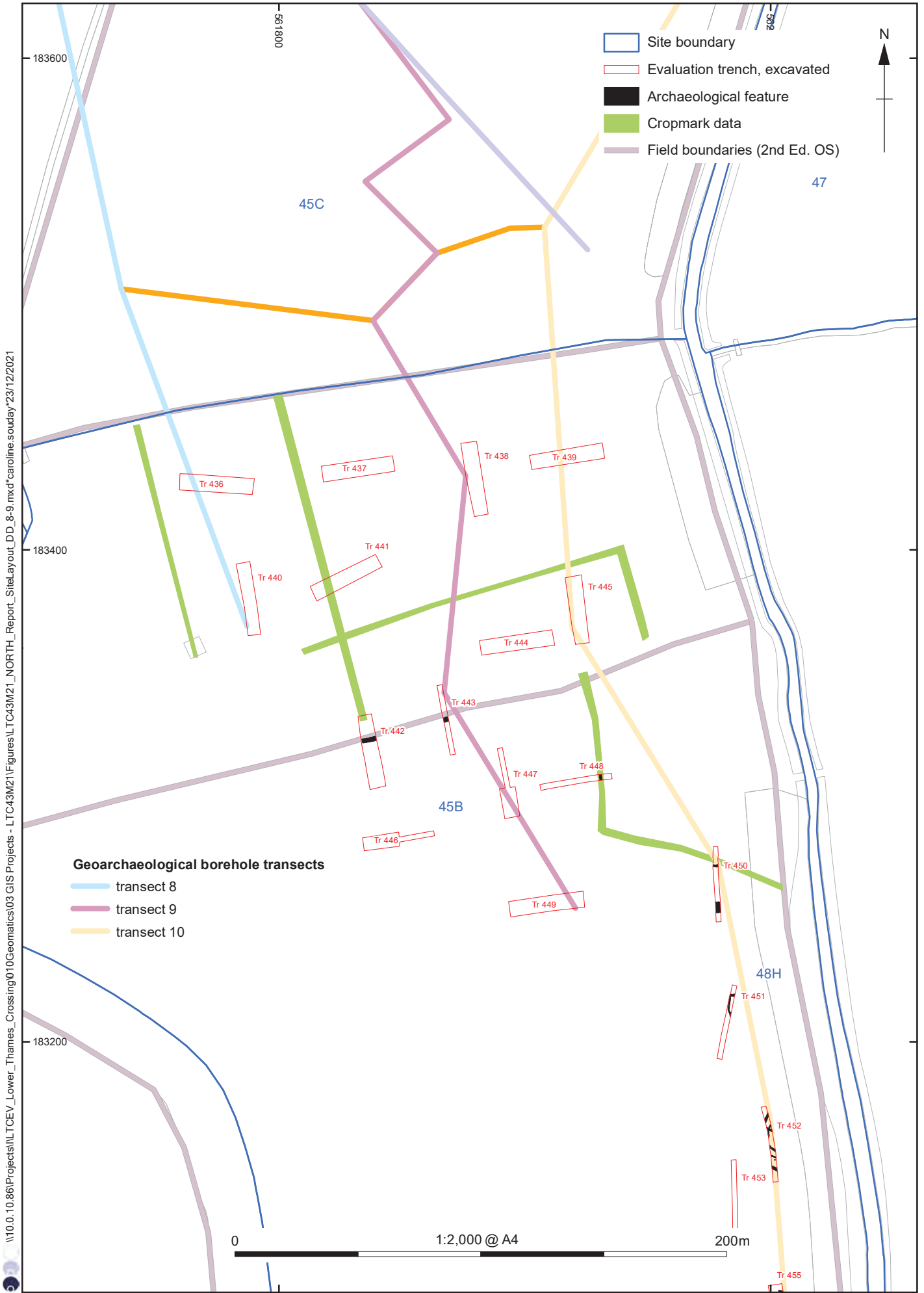

Contains Ordnance Survey data © Crown copyright and database right 2020, provided by client

Figure 8: Detailed overview of north half of Land Parcel 45B with cropmarks, historic mapping and archaeological features

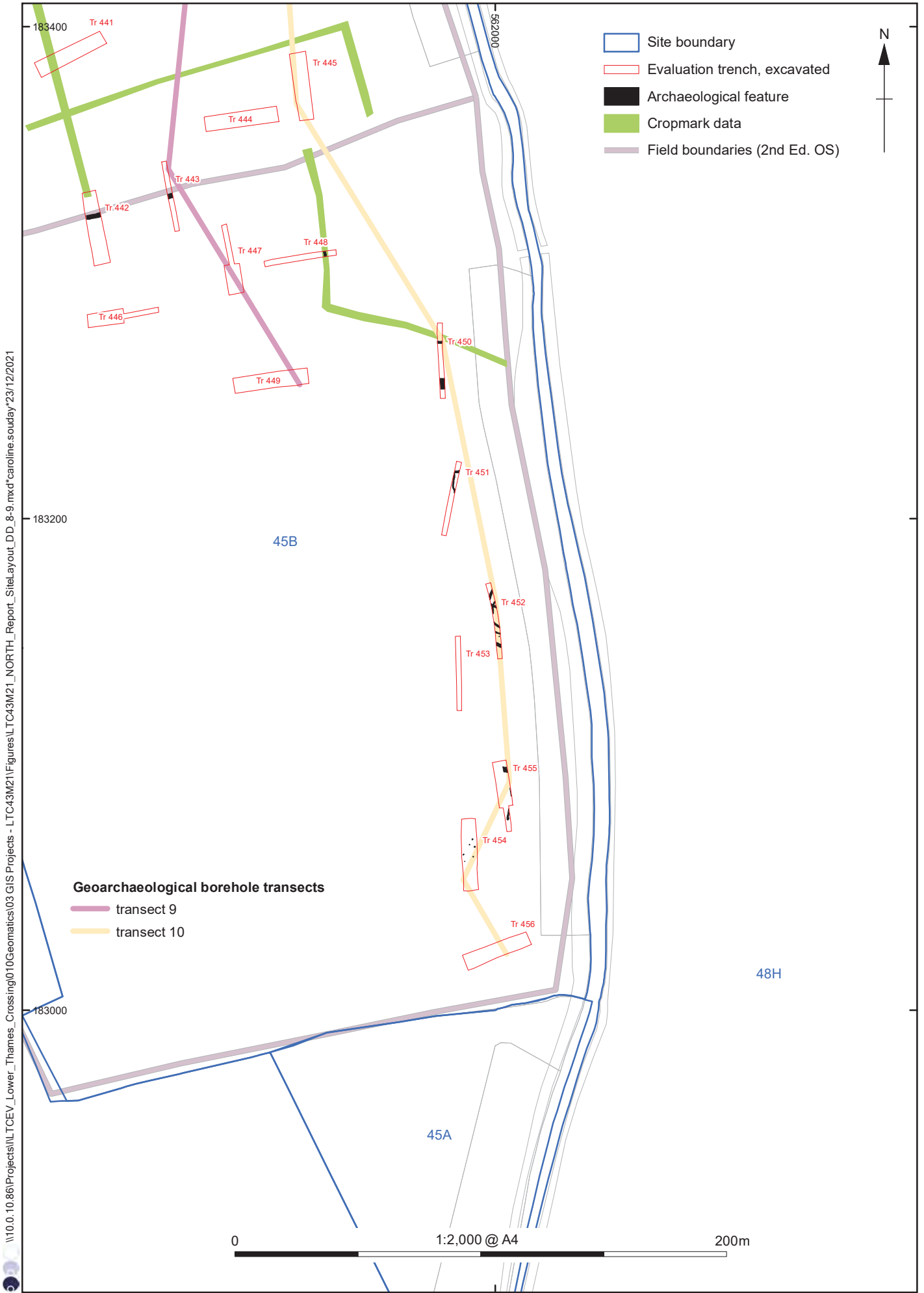

\\10.0.10.86\Projects\Lower_Thames_Crossing\010Geomatics\03 GIS Projects - LTC43M21\Figures\LTC43M21_NORTH_Report_SiteLayout_DD_8-9.mxd\caroline.souday\23/12/2021

Contains Ordnance Survey data © Crown copyright and database right 2020, provided by client

Figure 9: Detailed overview of south half of Land Parcel 45B with cropmarks, historic mapping and archaeological features



Figure 10: Detailed overview of north half of Land Parcel 46 with cropmarks, historic mapping and archaeological features

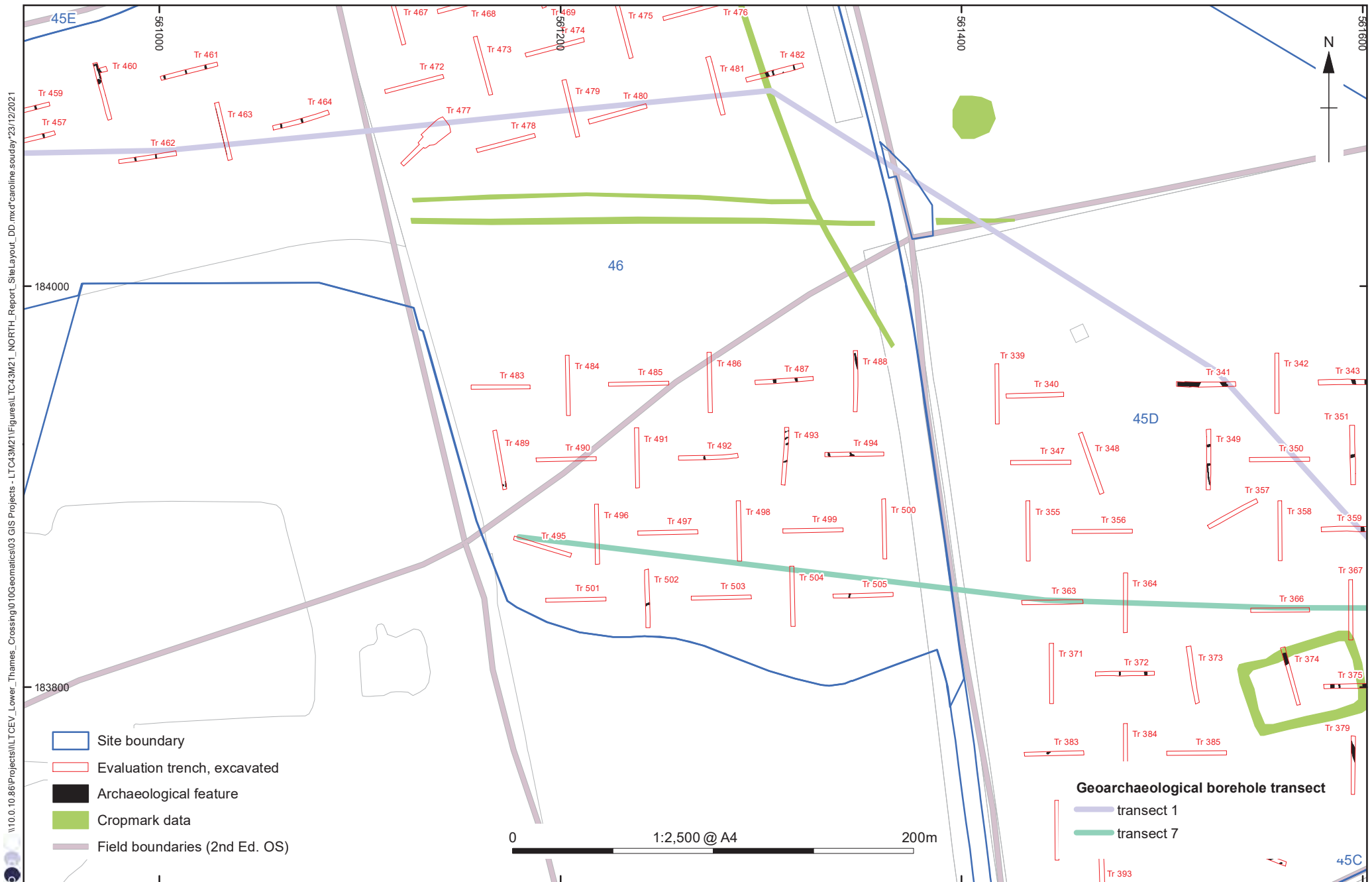

Contains Ordnance Survey data © Crown copyright and database right 2020, provided by client

Figure 11: Detailed overview of south half of Land Parcel 46 with cropmarks, historic mapping and archaeological features

\\10.0.10.86\Projects\ILTCEV_Lower_Thames_Crossing\010\DC\Geomatics\03 GIS Projects - LTC43M21\Figures\LTC43M21_NORTH_Report_L_SiteLayout_DD.mxd\caroline.souday\23/12/2021

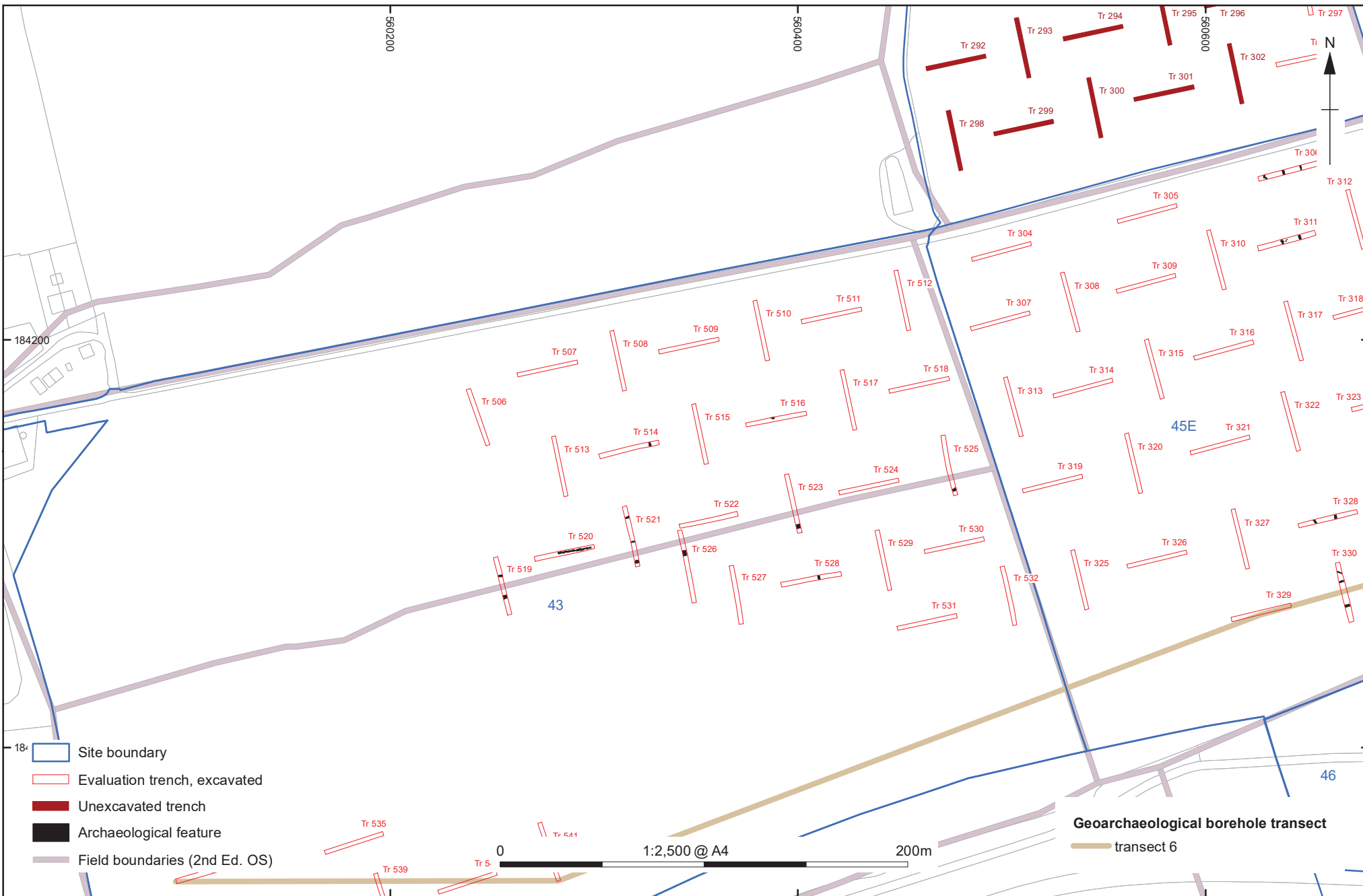

Contains Ordnance Survey data © Crown copyright and database right 2020, provided by client

Figure 12: Detailed overview of east half of Land Parcel 43 with cropmarks, historic mapping and archaeological features

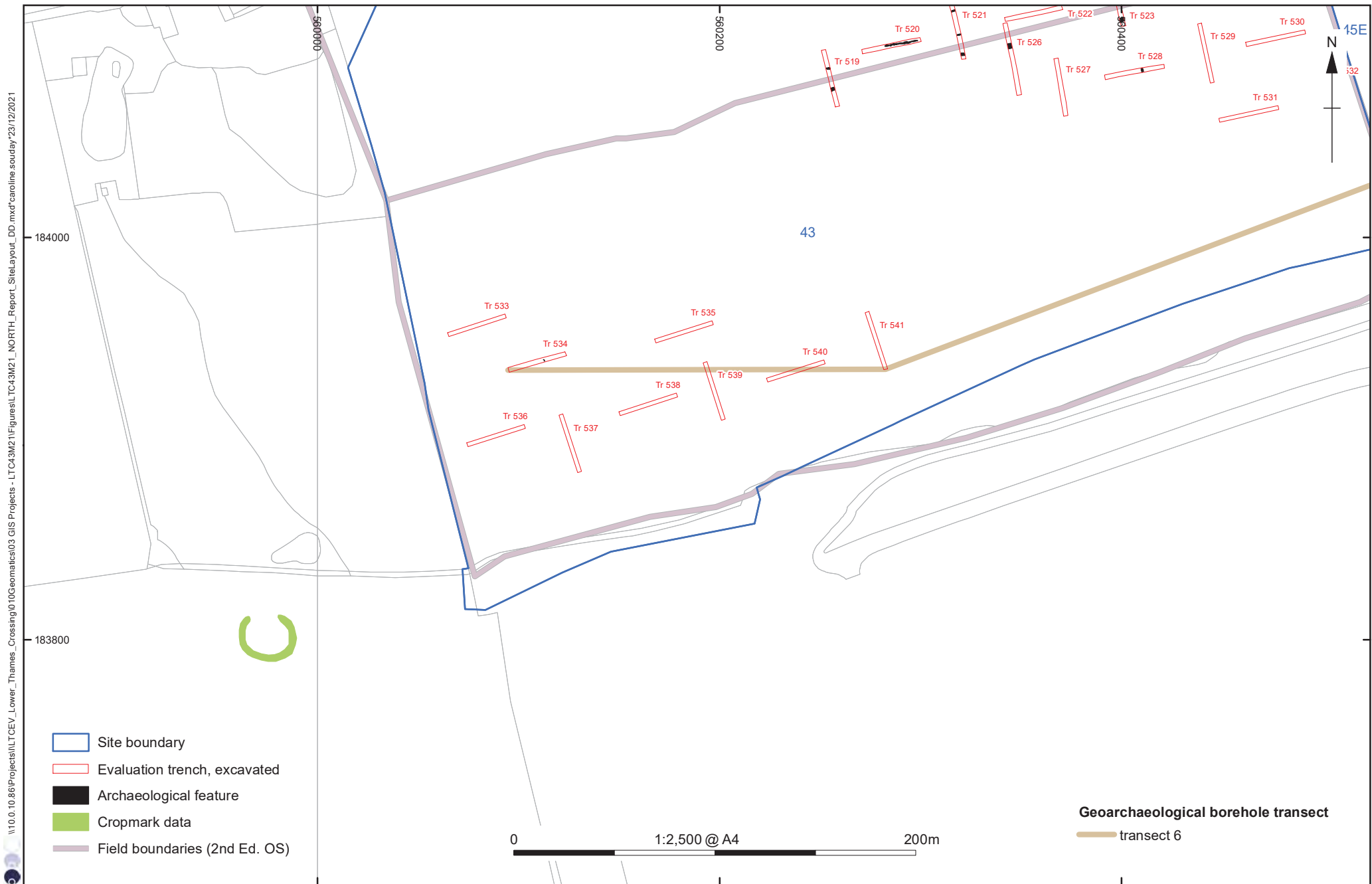

\\10.0.10.86\Projects\LTCEV_Lower_Thames_Crossing\010\Geoematics\03 GIS Projects - LTC43M2\1\Figures\LTC43M2_1_NORTH_Report_L_SiteLayout_DD.mxd\caroline.soudey\23/12/2021

Contains Ordnance Survey data © Crown copyright and database right 2020, provided by client

Figure 13: Detailed overview of west half of Land Parcel 43 with cropmarks, historic mapping and archaeological features

\\10.0.10.86\Projects\TCEV_Lower_Thames_Crossing\10\Geomatics\03 GIS Projects - LTC43M21\Figures\LTC43M21_NORTH_Report_TrenchPlans_DD_A3P.mxd*caroline.souday*23/12/2021

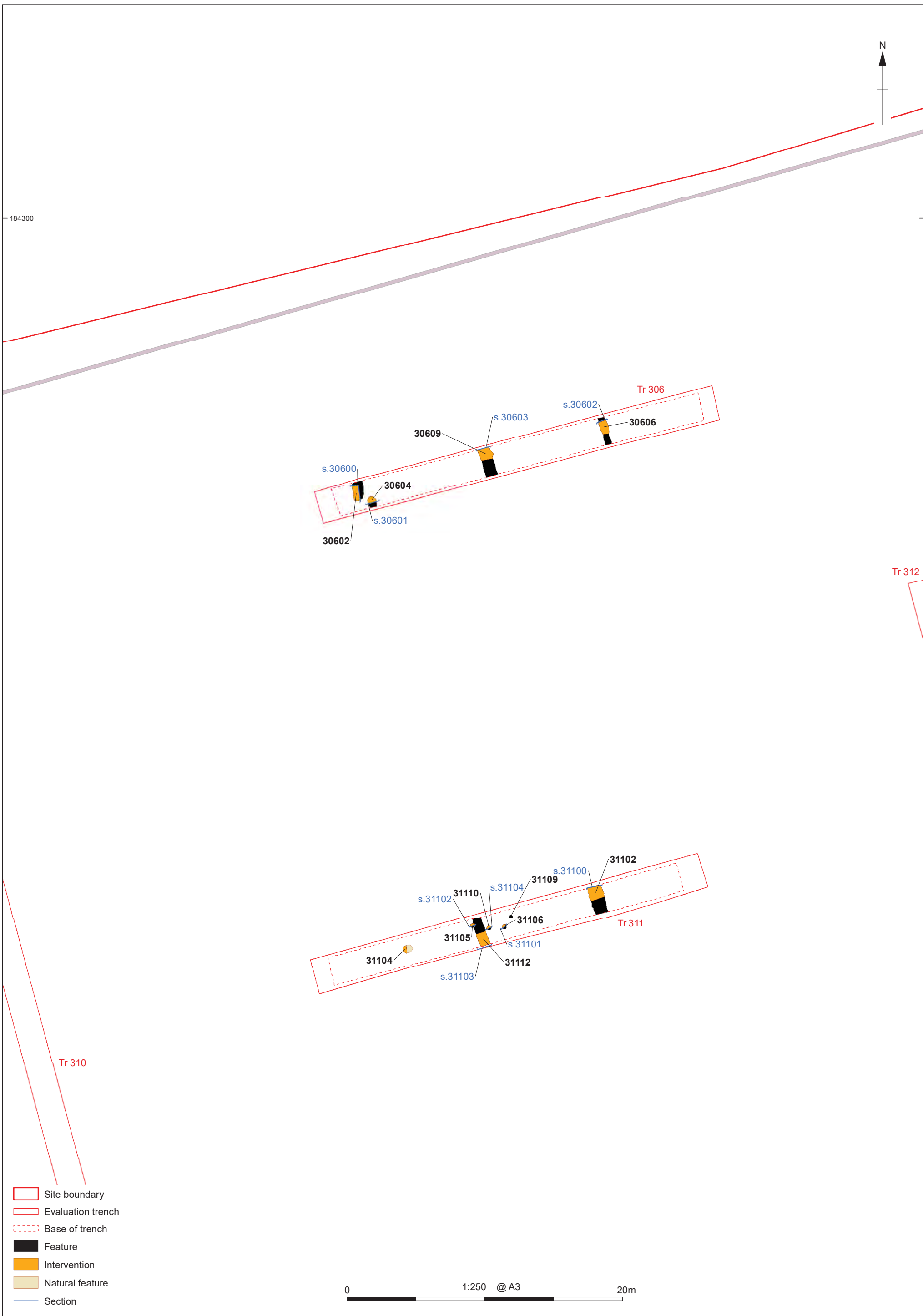
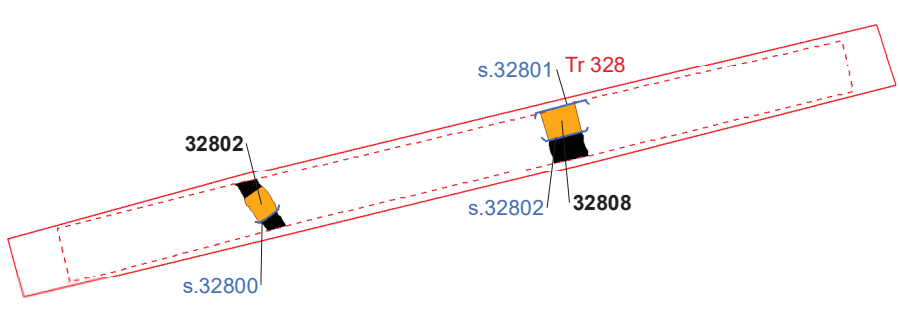
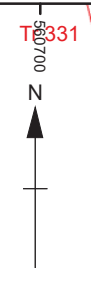
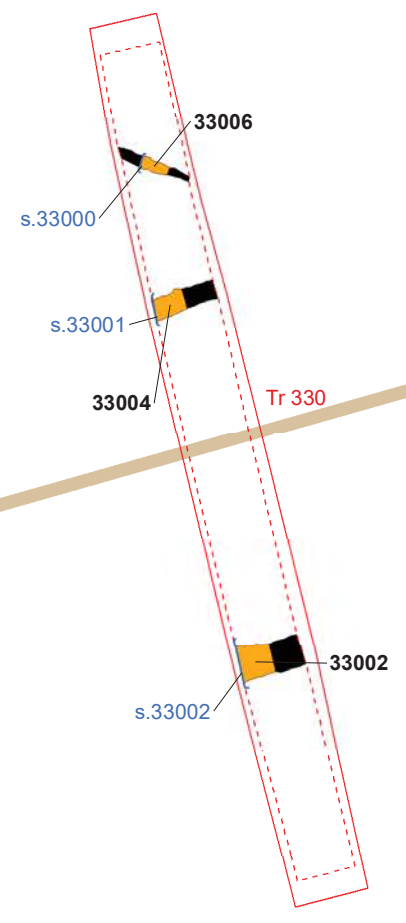

Figure 14: Plan of Trenches 306 and 311



184100



Tr 329

- Site boundary
- Evaluation trench
- Base of trench
- Feature
- Intervention
- Section

Geoarchaeological borehole transects
Transect 6





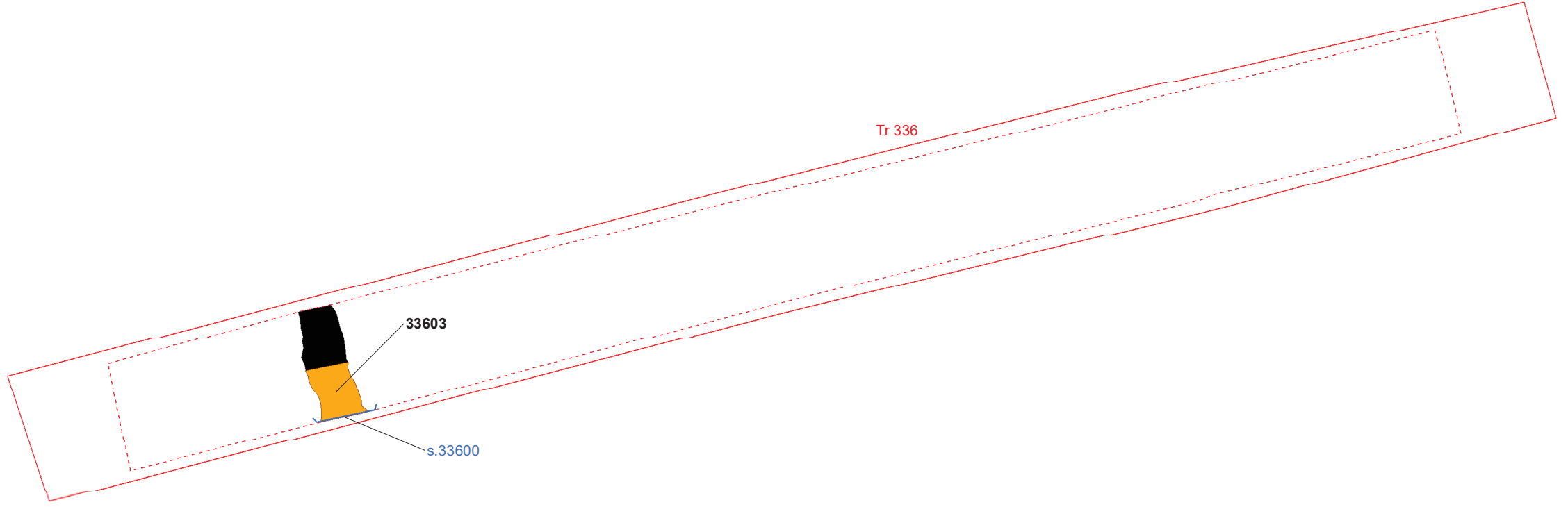

0 1:250 @ A3 20m

\\10.0.10.86\Projects\TCEV_Lower_Themes_Crossing\010\Geomatics\03 GIS Projects - LTC43M21\Figures\LTC43M21\North_Report_TrenchPlans_DD_A3P.mxd*caroline.souday*23/12/2021

1st Edition OS. Data provided by client

Figure 15: Plan of Trenches 328 and 330



-  Site boundary
-  Evaluation trench
-  Base of trench
-  Feature
-  Intervention
-  Section

0 1:100 @ A3 5m

Figure 16: Plan of Trench 336

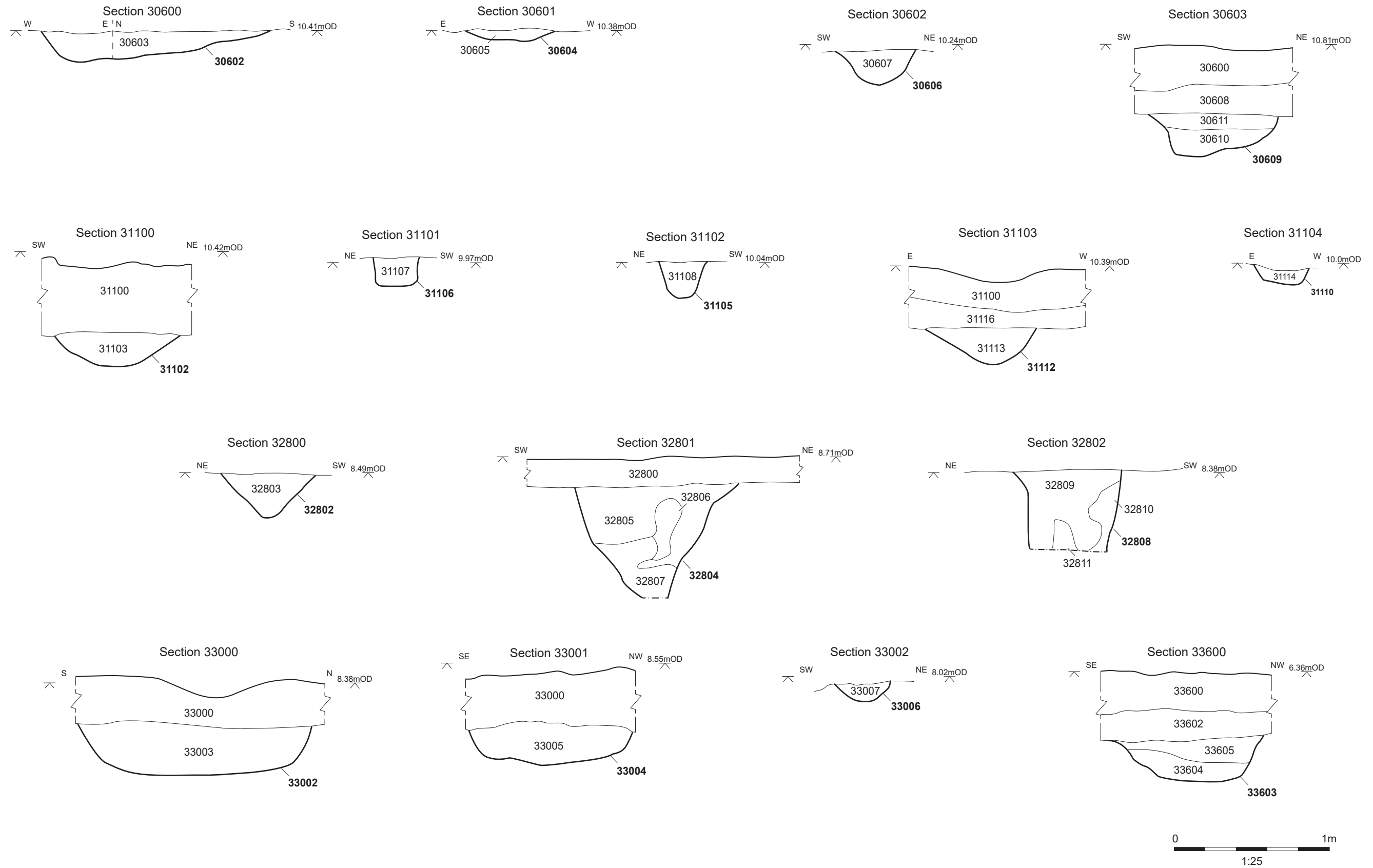
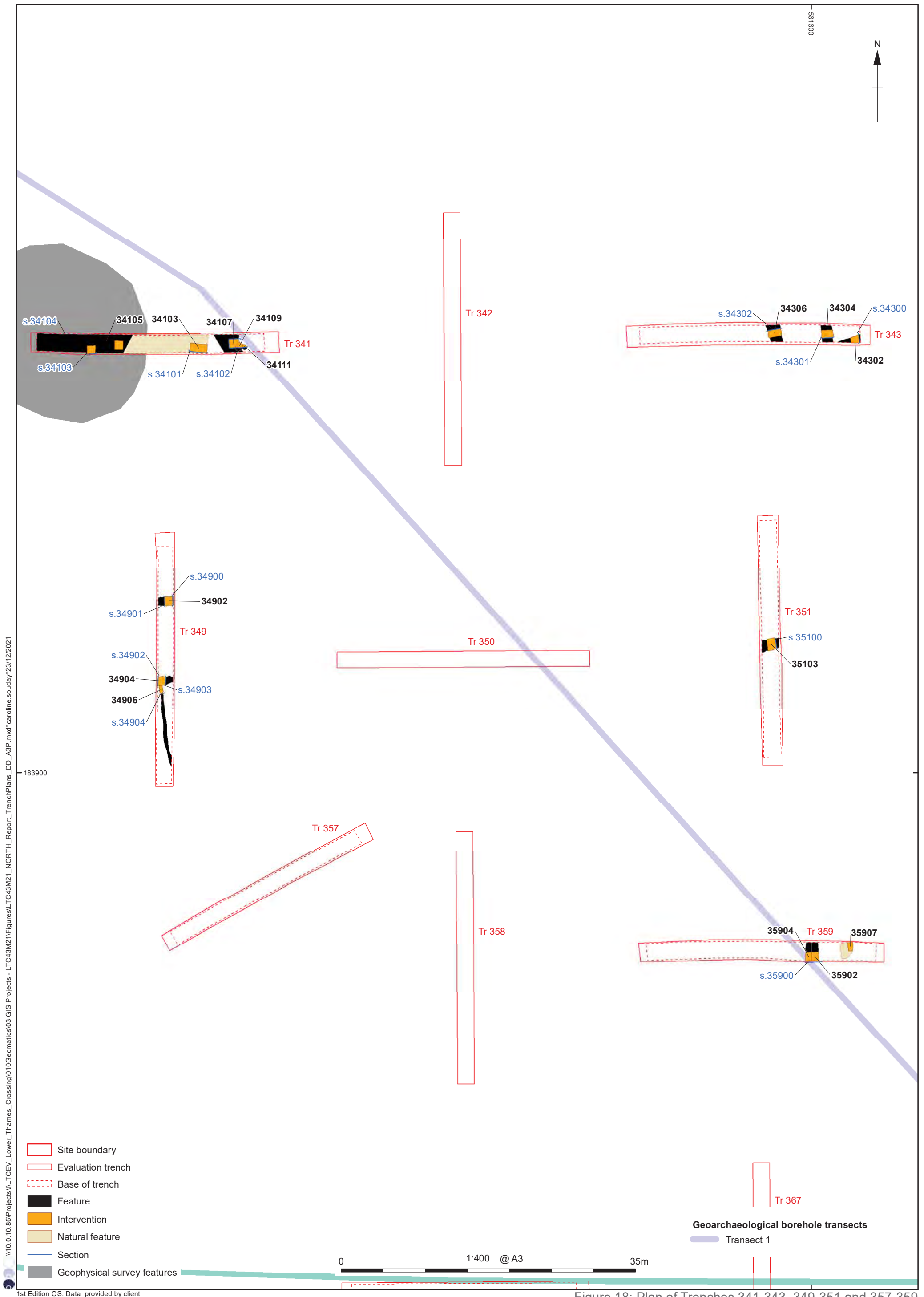

Figure 17: Sections (Trenches 306, 311, 328, 330 and 336)



\\10.0.10.86\Projects\Lower_Themes_Crossing\010\Geomatics\03 GIS Projects - LTC43M21\Figures\LTC43M21_NORTH_Report_TrenchPlans_DD_A3P.mxd*caroline.souday*23/12/2021

1st Edition OS. Data provided by client

Figure 18: Plan of Trenches 341-343, 349-351 and 357-359

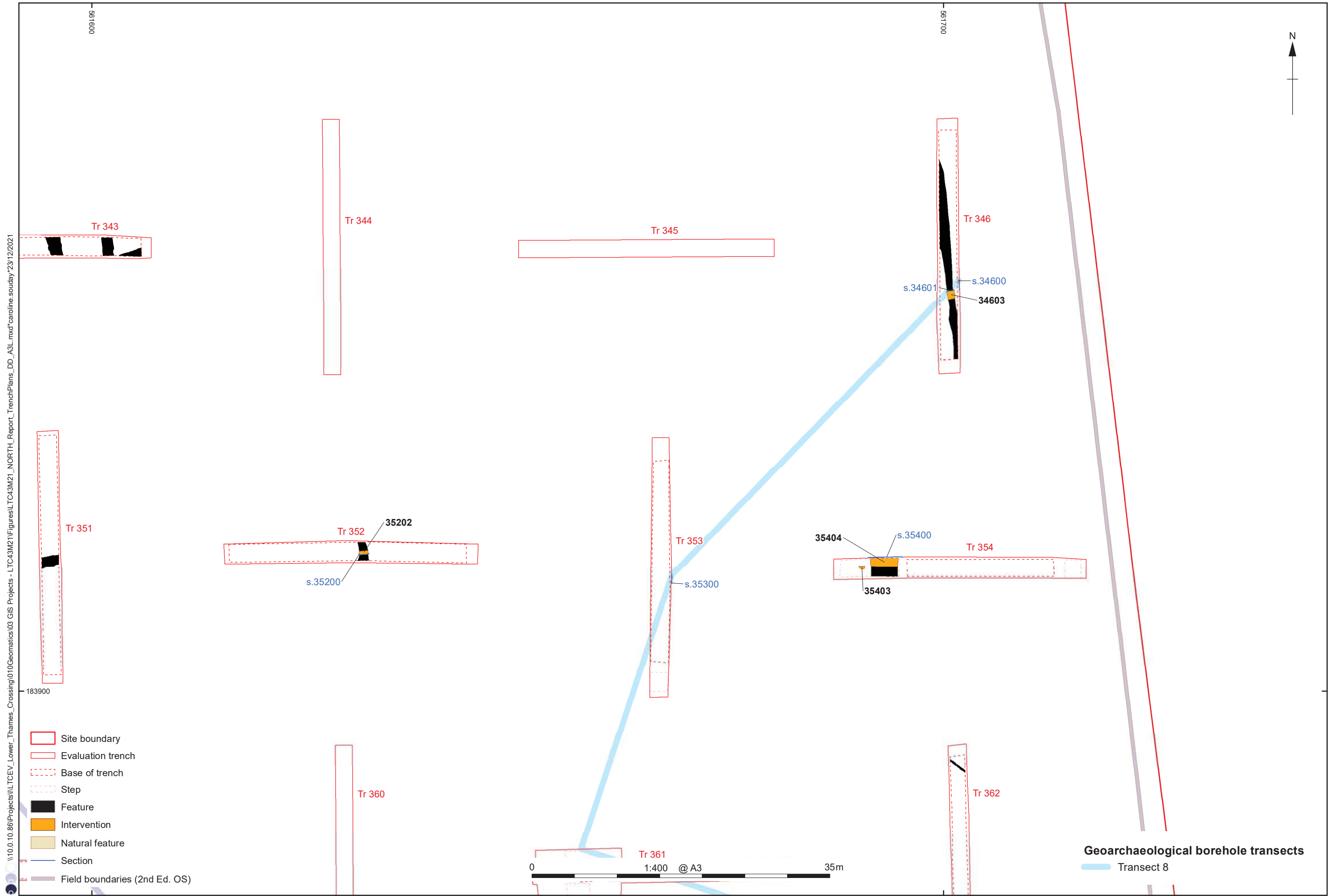

\\10.0.10.86\Projects\Lower_Thames_Crossing\010\Geomatics\03 GIS Projects - LTC43M21\Figures\LTC43M21_NORTH_Report_TrenchPlans_DD_A3L.mxd*caroline.souday*23/12/2021

Figure 19: Plan of Trenches 344-346 and 352-354

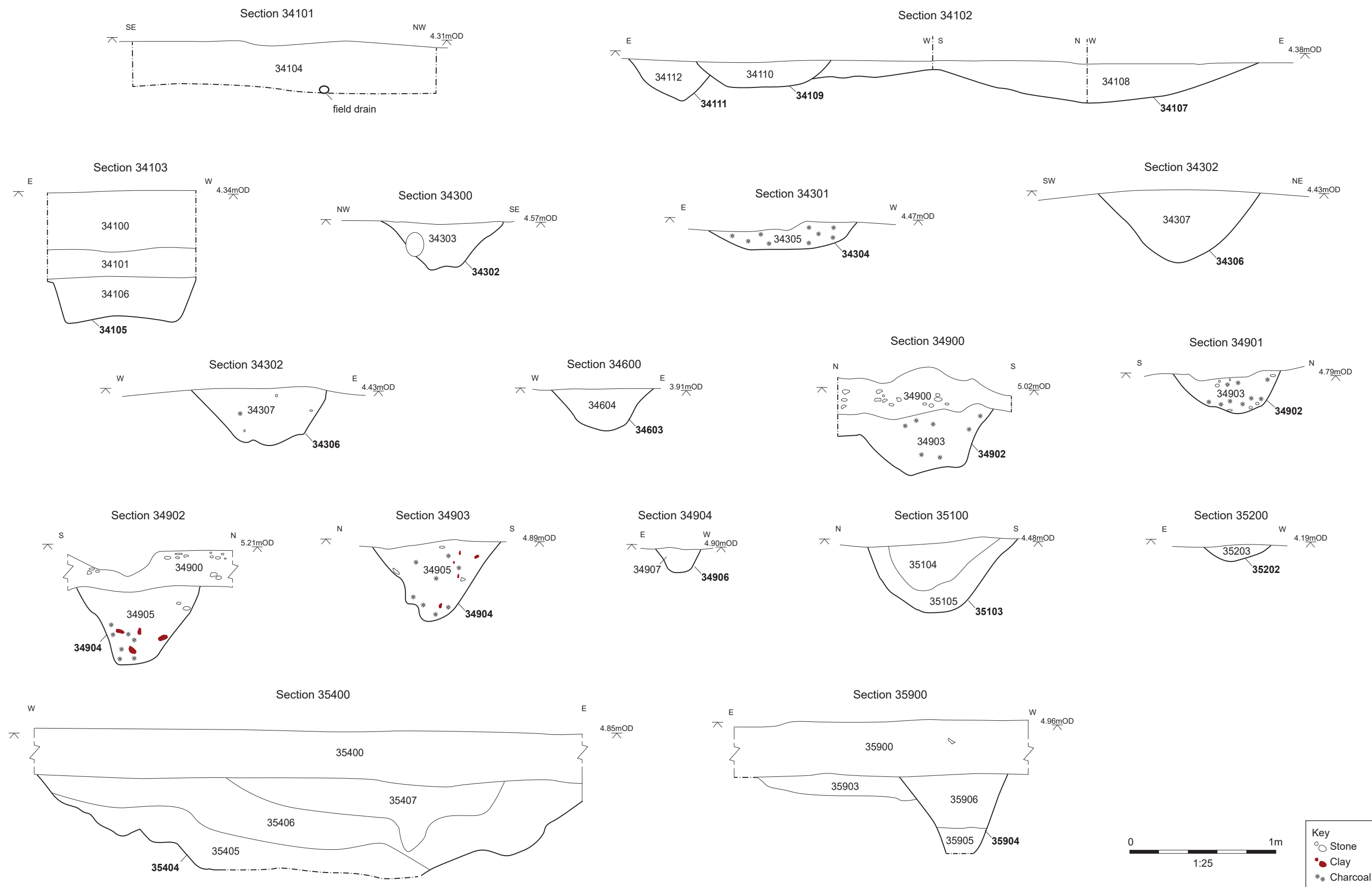

Figure 20: Sections (Trenches 341, 343, 346, 349, 351, 352, 354 and 359)

\\10.0.10.86\Projects\Lower_Thames_Crossing\010\Geomatics\GIS\Projects - LTC43M21\Figures\LTC43M21_NORTH_Report_TrenchPlans_DD_A3L.mxd*caroline.souday*23/12/2021

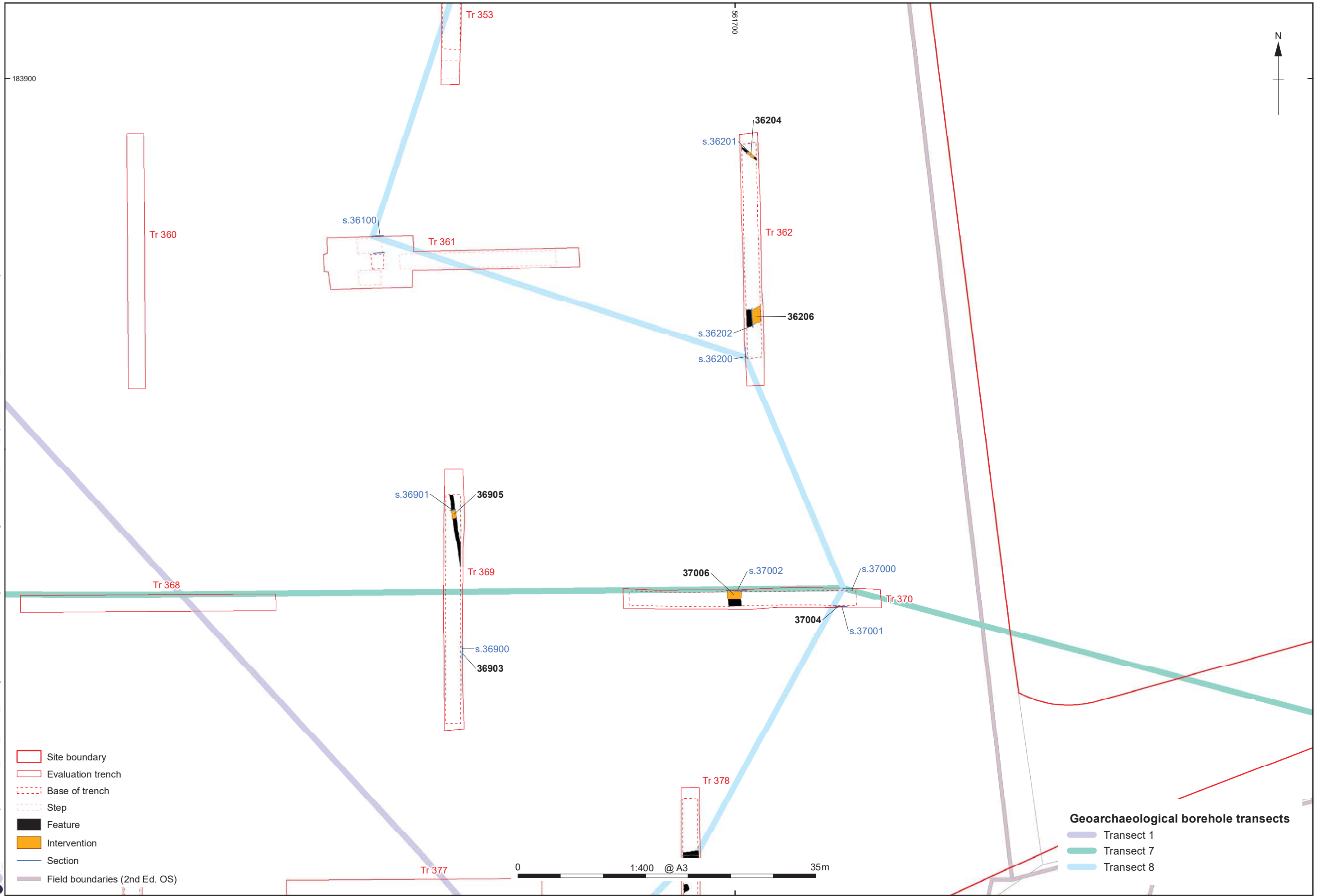
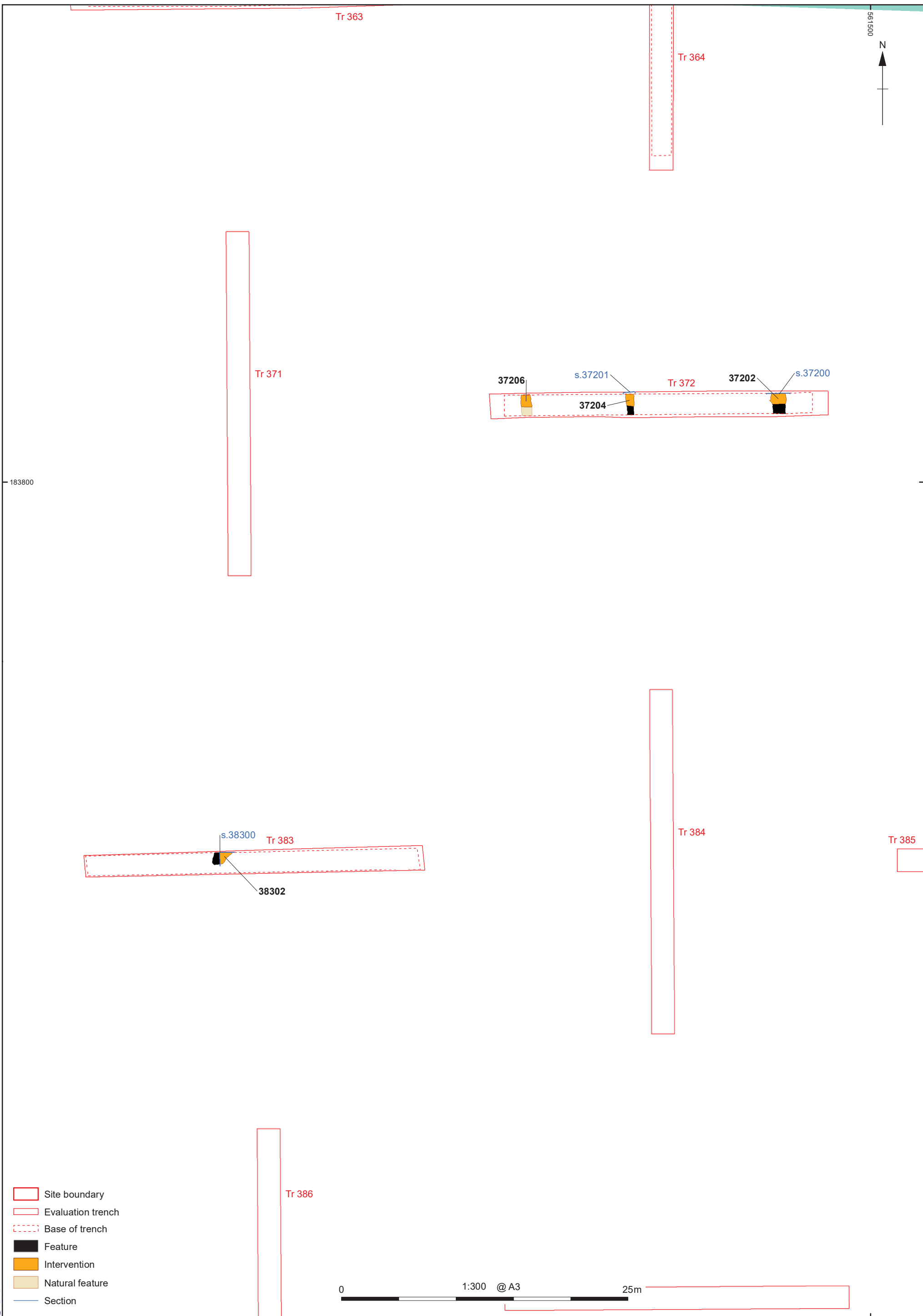

Figure 21: Plan of Trenches 361-362 and 369-370

\\10.0.10.86\Projects\Lower_Themes_Crossing\10\Geomatics\03 GIS Projects - LTC43M21\Figures\LTC43M21_NORTH_Report_TrenchPlans_DD_A3P.mxd*caroline.souday*23/12/2021



1st Edition OS. Data provided by client

Figure 22: Plan of Trenches 371-372 and 383-384

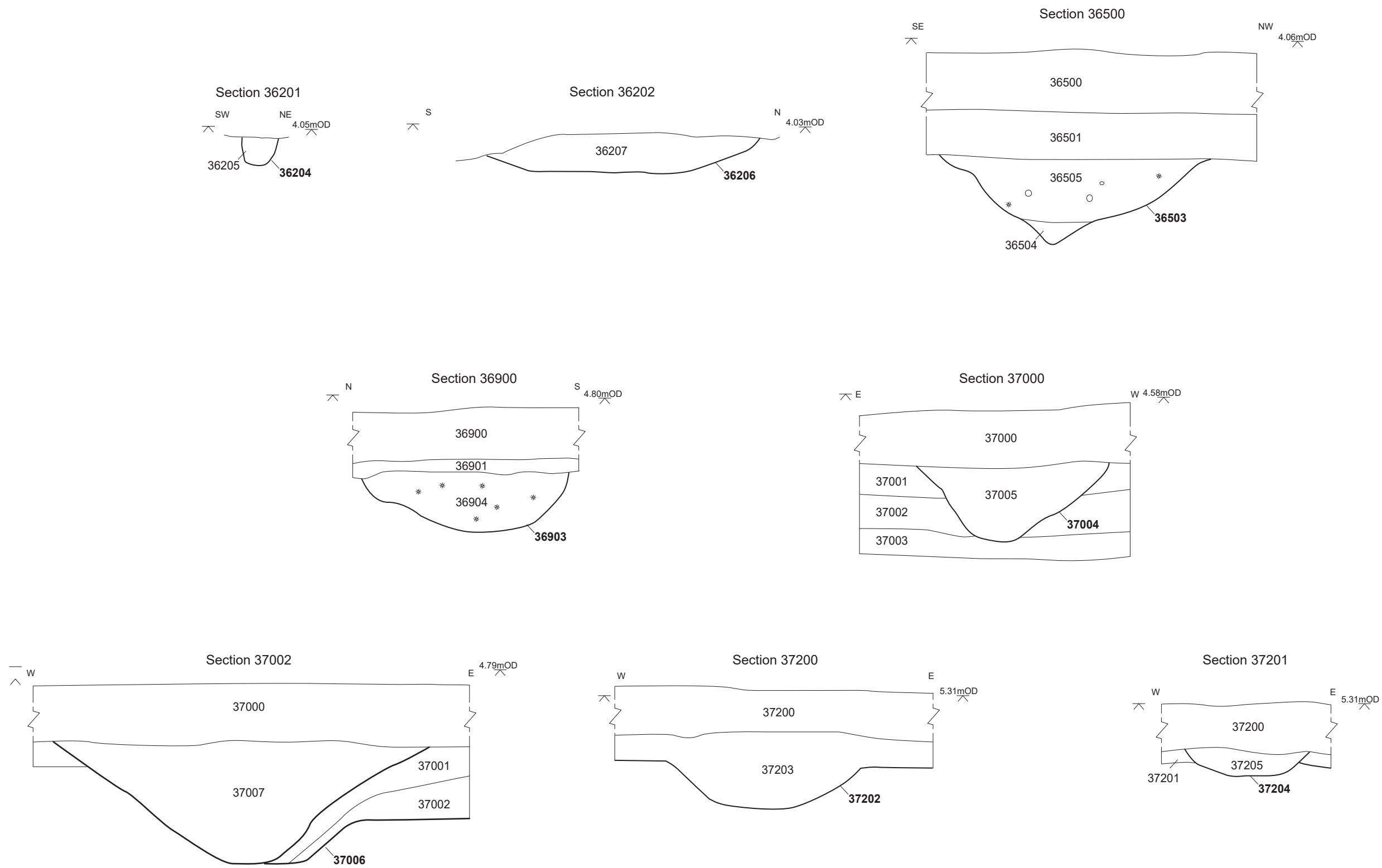

Key
○ Stone
Charcoal

Figure 23: Sections (Trenches 362, 365, 369, 370 and 372)

\\10.10.86\Projects\Lower_Thames_Crossing\010\Geomatics\03 GIS Projects - LTC43M2\Figures\LTC43M21_NORTH_Report_TrenchPlans_DD_A3L.mxd*caroline.souday*23/12/2021

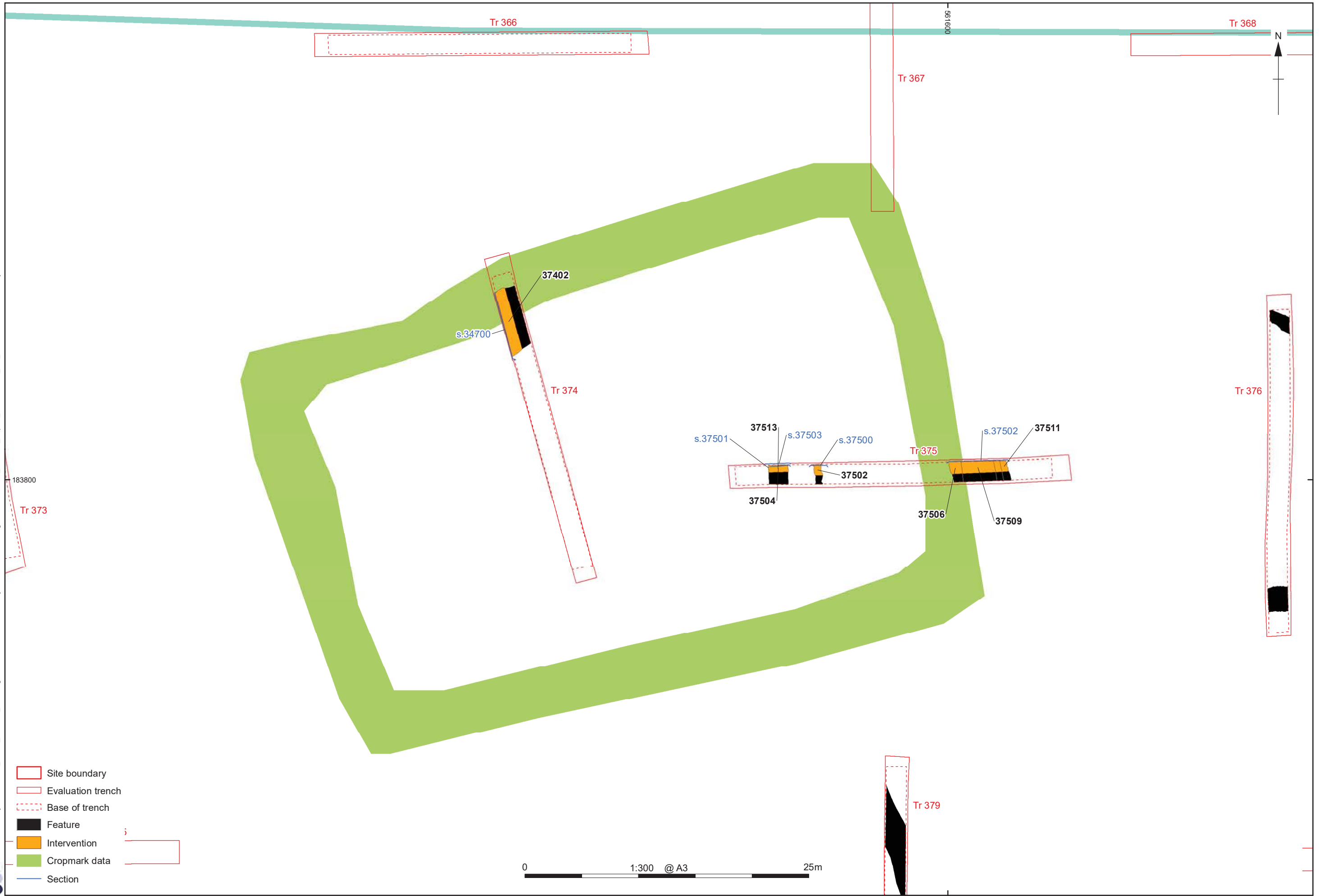

- Site boundary
- Evaluation trench
- Base of trench
- Feature
- Intervention
- Cropmark data
- Section

0 1:300 @ A3 25m

Figure 24: Plan of Trenches 374-375

\\10.0.10.86\Projects\ILTC\Lower_Thames_Crossing\010\Geomatics\03 GIS Projects - LTC43M21\Figures\LTC43M21_NORTH_Report_TrenchPlans_DD_A3L.mxd*caroline.souday*23/12/2021

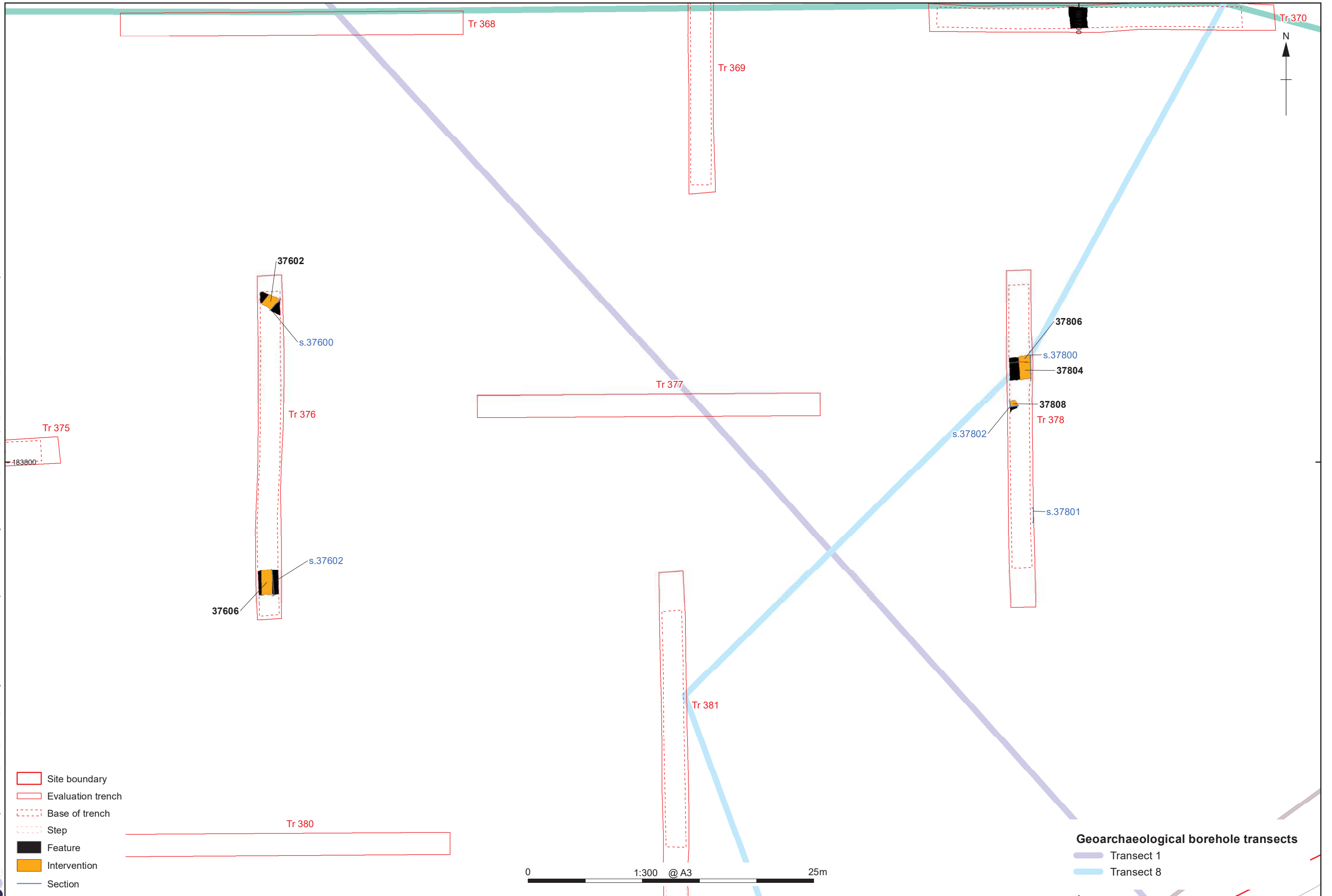

Geoarchaeological borehole transects
 - Transect 1
 - Transect 8

Figure 25: Plan of Trenches 376 and 378

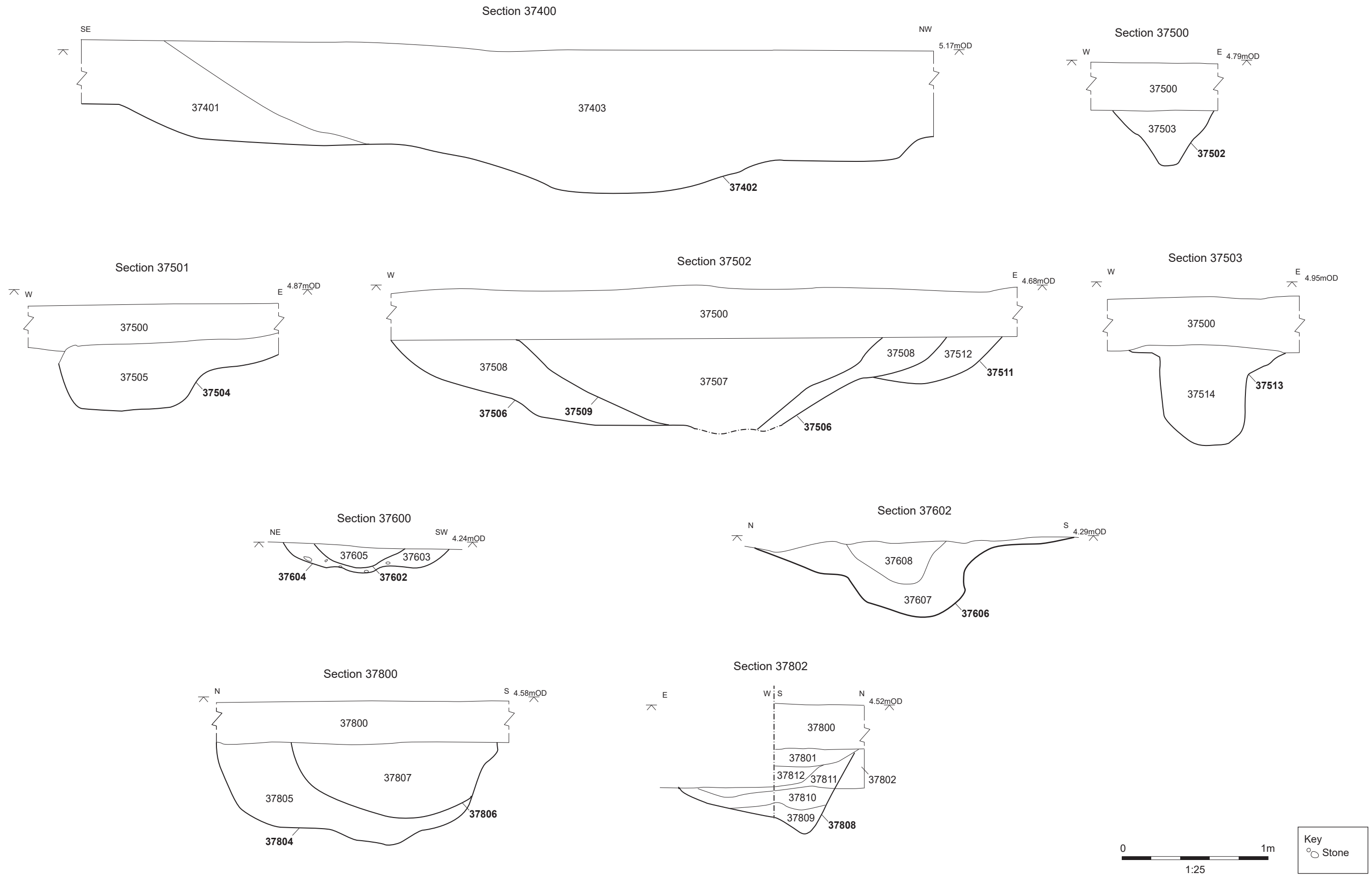

Figure 26: Sections (Trenches 374, 375, 376 and 378)

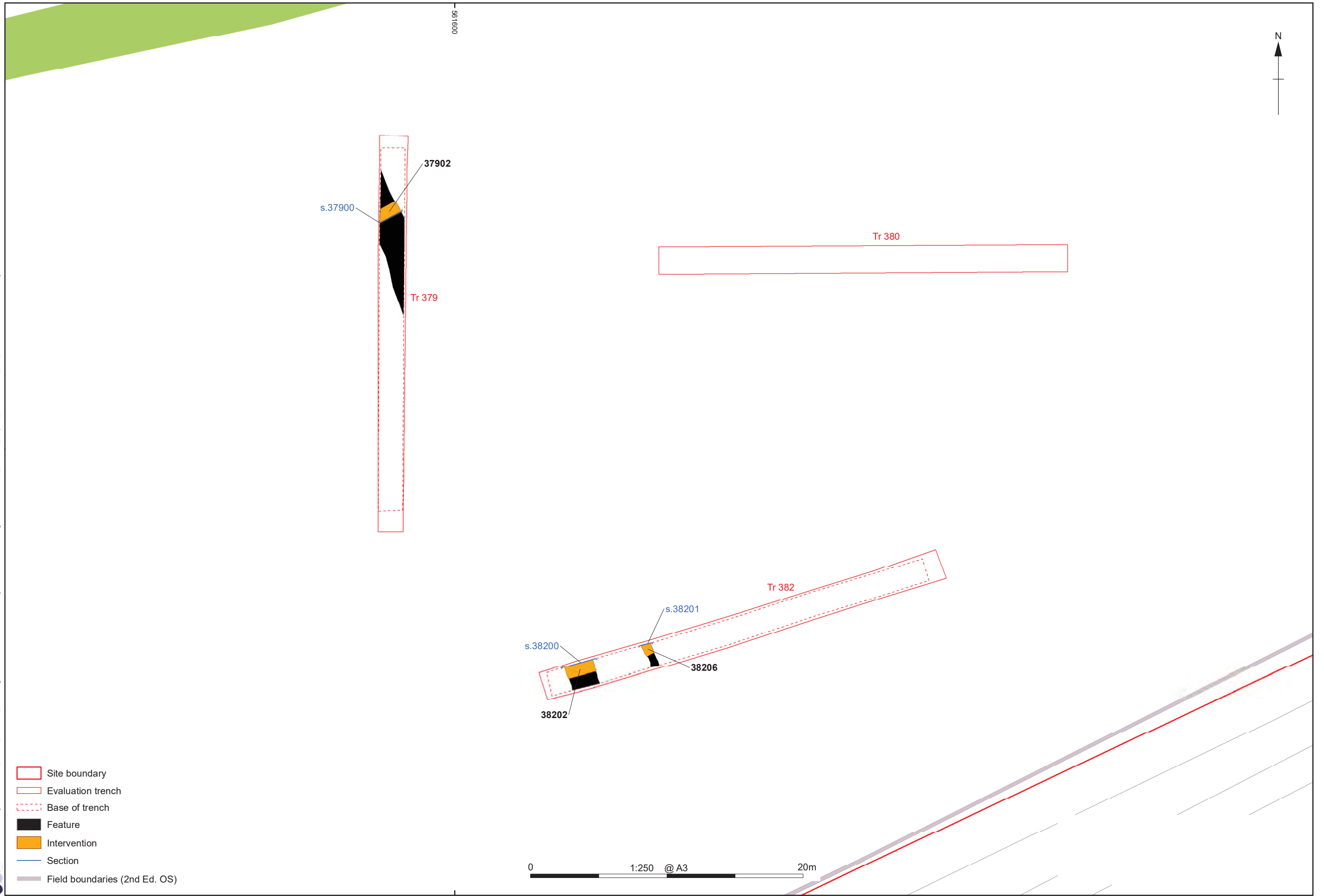

Figure 27: Plan of Trenches 379-380 and 382

\\10.0.10.86\Projects\ILTCEV_Lower_Thames_Crossing\010\Geomatics\03 GIS Projects - LTC43M21\Figures\LTC43M21_NORTH_Report_TrenchPlans_DD_A3L.mxd*caroline.souday*23/12/2021

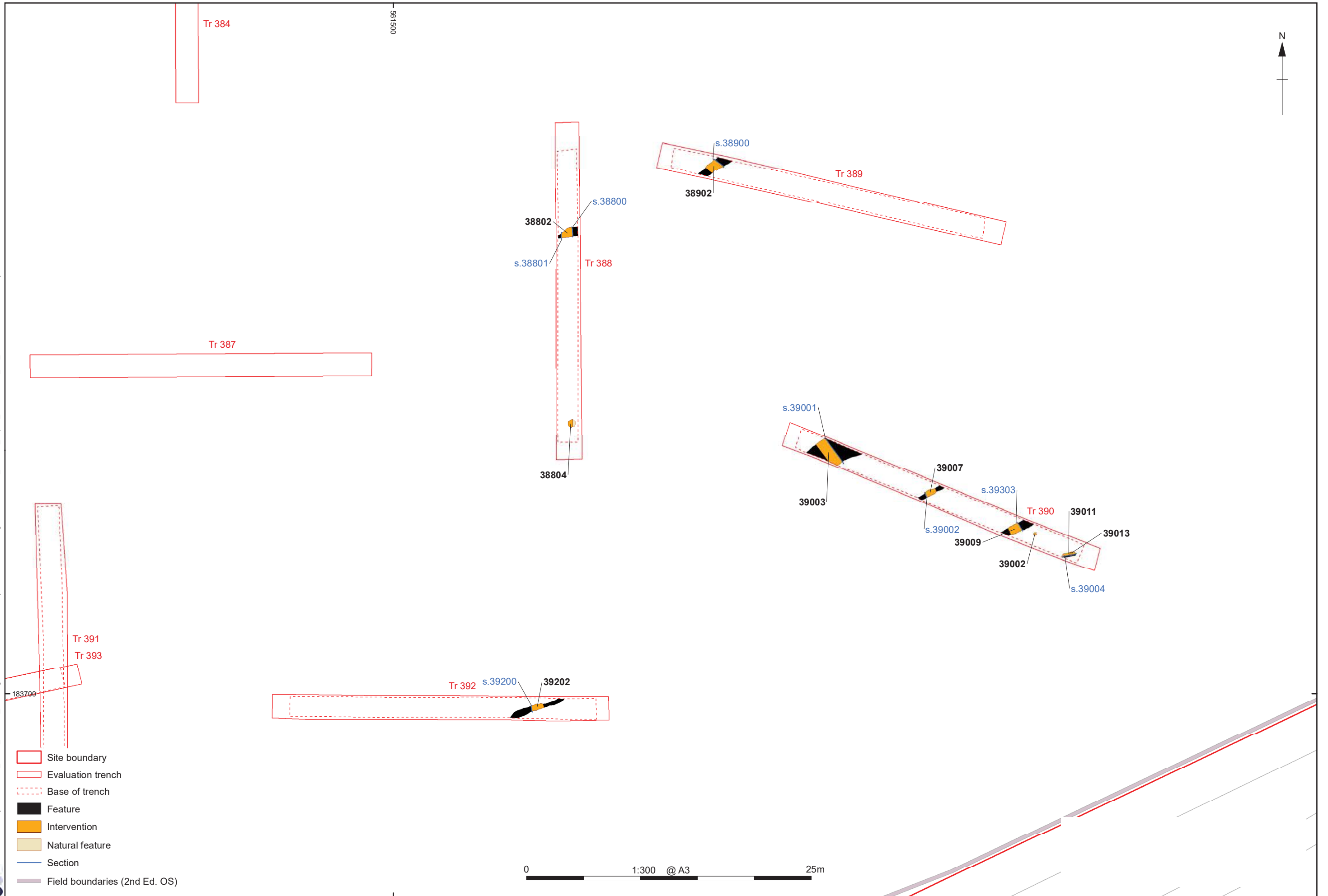

Figure 28: Plan of Trenches 388-390 and 392

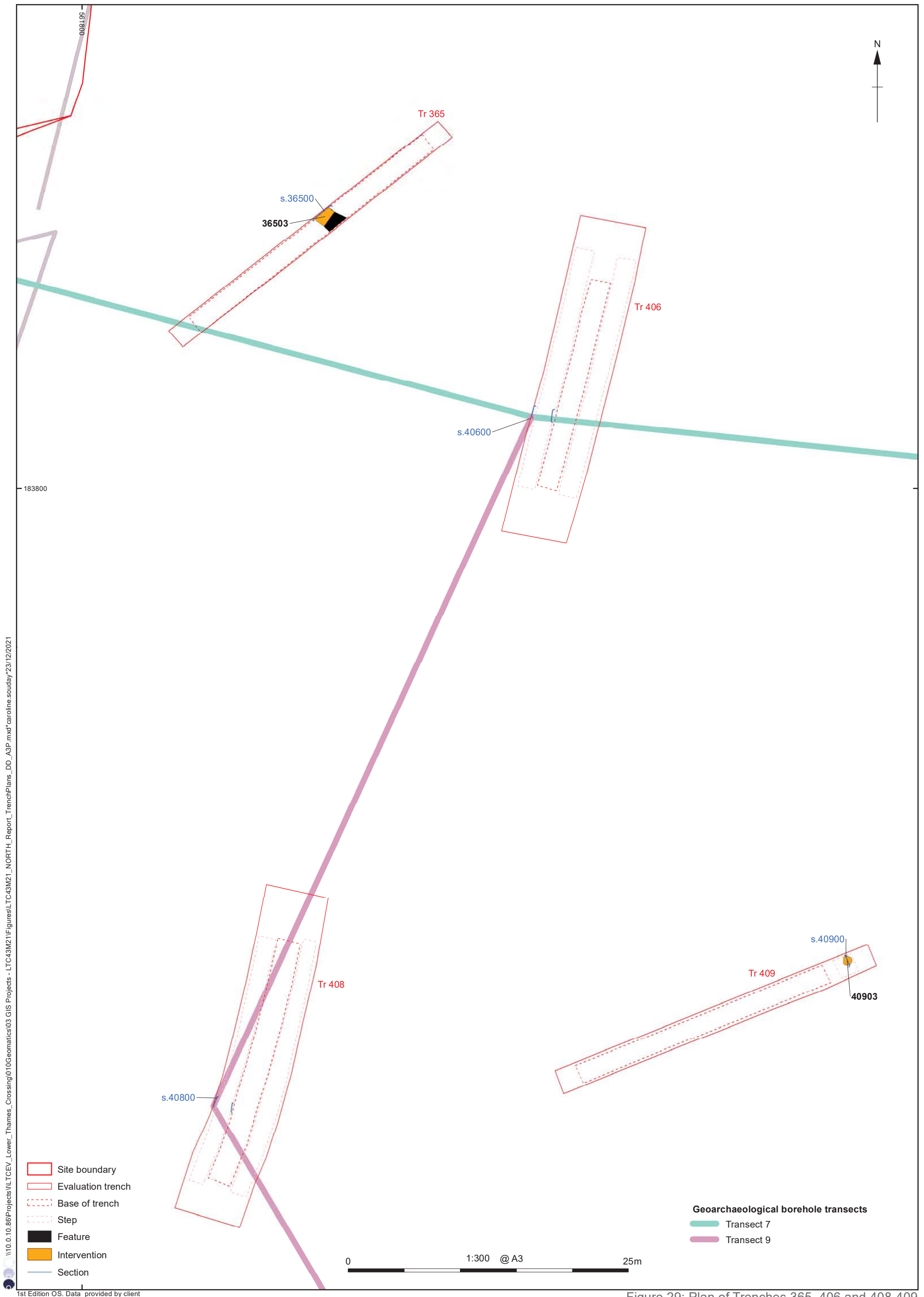
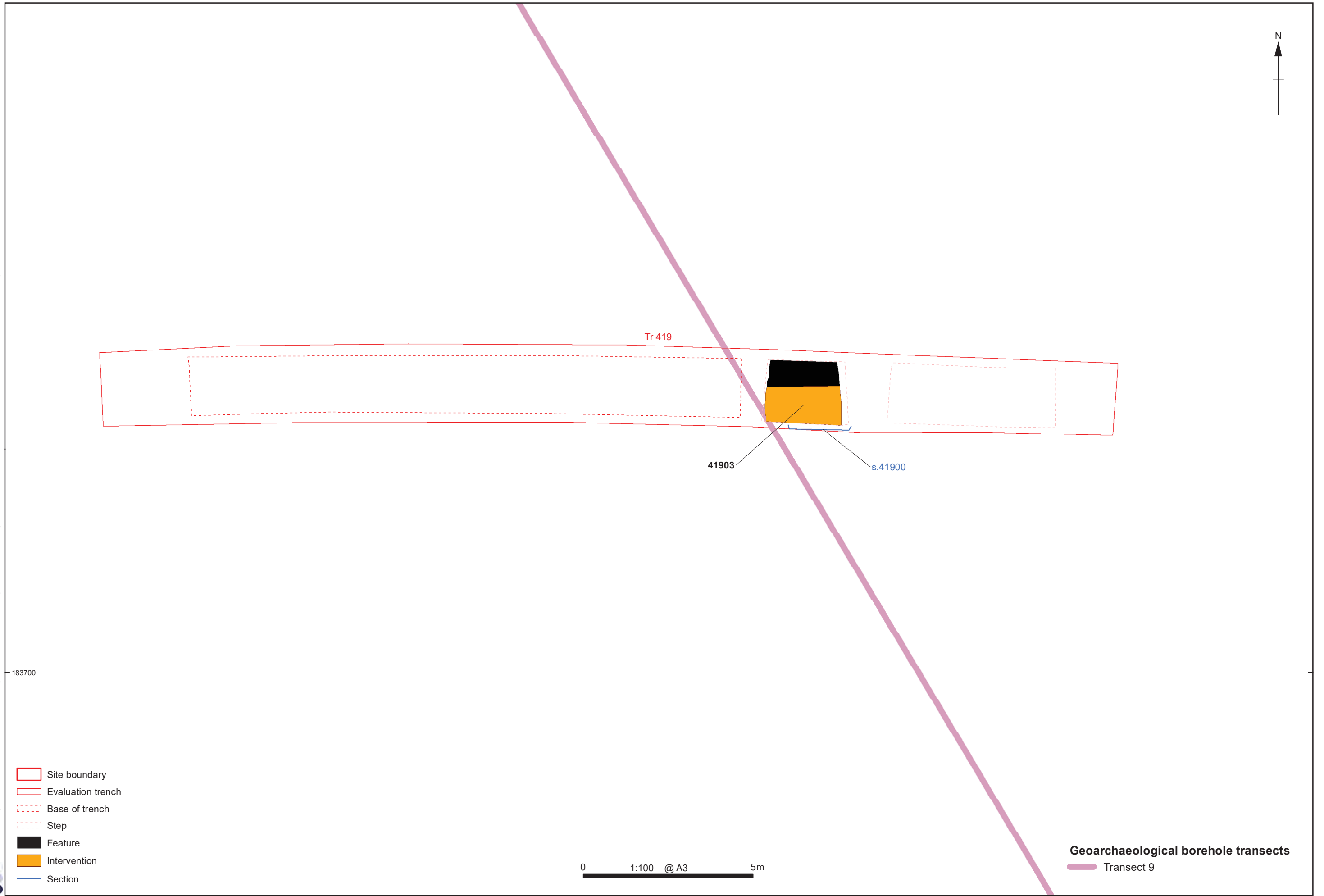

Figure 29: Plan of Trenches 365, 406 and 408-409

\\10.0.10.86\Projects\ILTCEV_Lower_Thames_Crossing\010\Geomatics\03 GIS Projects - LTC43M21\Figures\LTC43M21_NORTH_Report_TrenchPlans_DD_A3L.mxd*caroline.souday*23/12/2021



Geoarchaeological borehole transects
 — Transect 9

Figure 30: Plan of Trench 419

\\10.0.10.86\Projects\Lower_Thames_Crossing\010\Geomatics\03 GIS Projects - LTC43M21\Figures\LTC43M21_NORTH_Report_TrenchPlans_DD_A3P.mxd*caroline.souday*23/12/2021

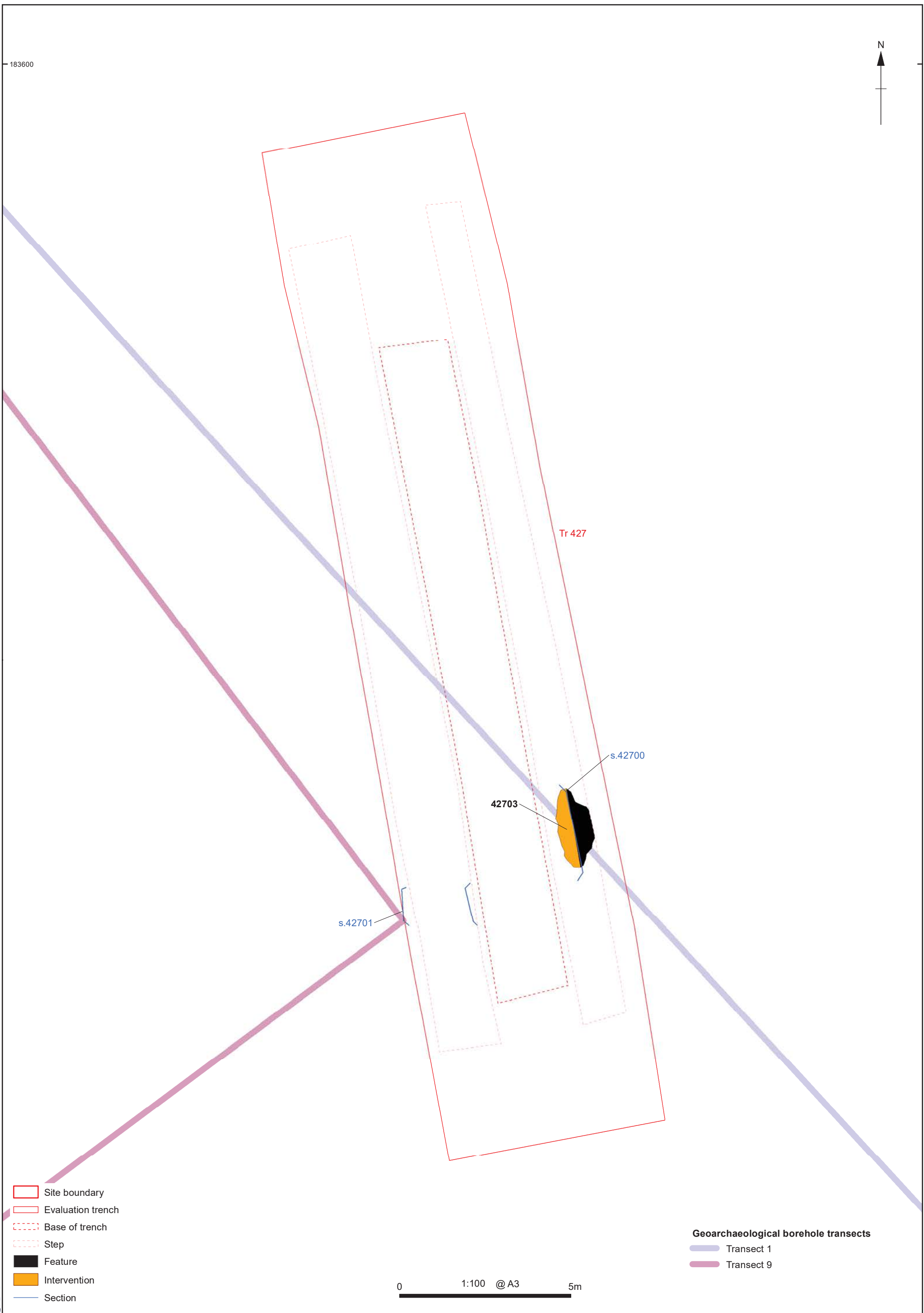

1st Edition OS. Data provided by client

Figure 31: Plan of Trench 427

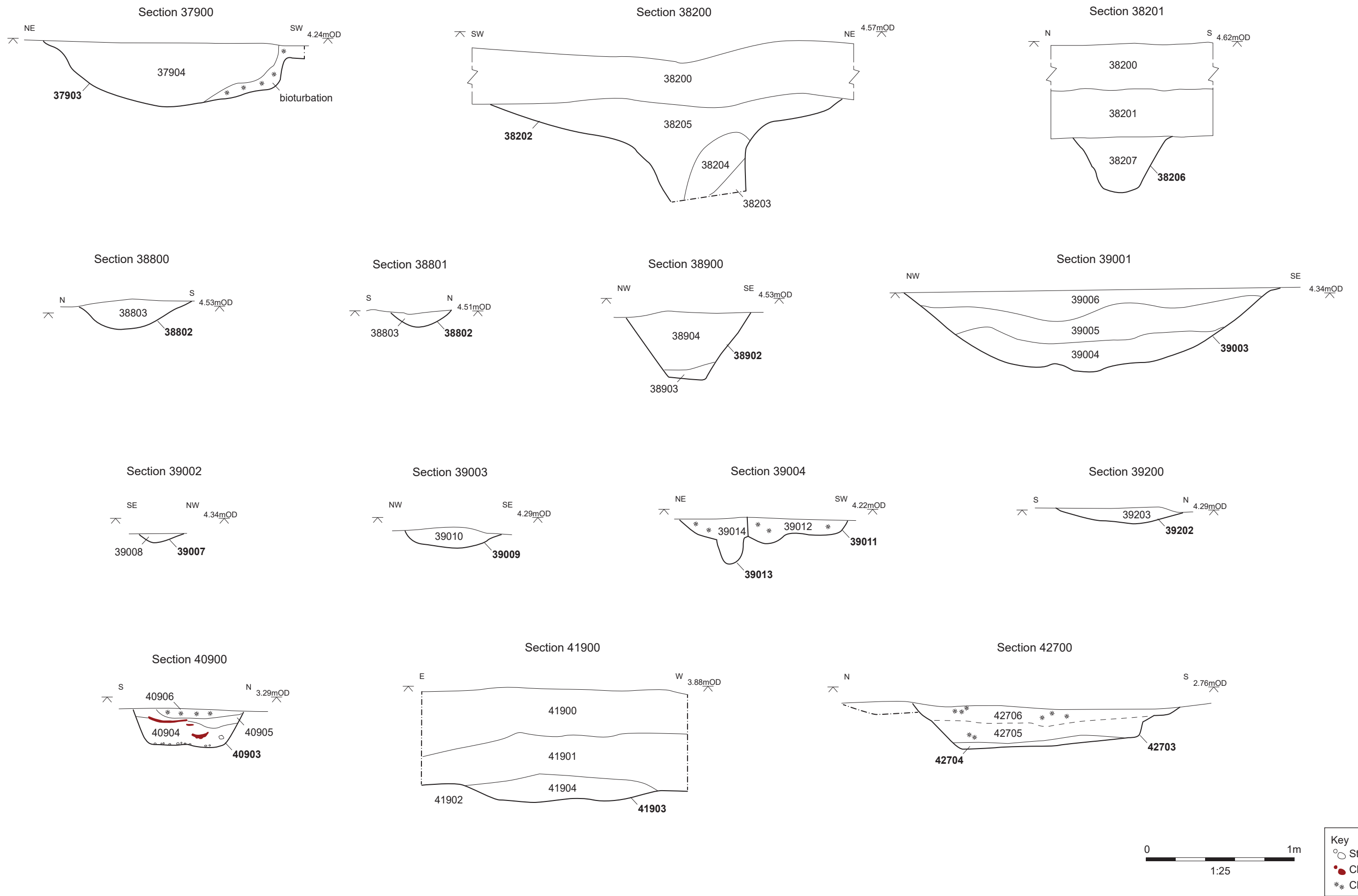

Figure 32: Sections (Trenches 379, 382, 388, 389, 390, 392, 409, 419 and 427)

\\10.0.10.86\Projects\ILTCEV_Lower_Themes_Crossing\010Geomatics\03 GIS Projects - LTC43M2\Figures\LTC43M21_NORTH_Report_TrenchPlans_DD_A3L.mxd*caroline.souday*23/12/2021

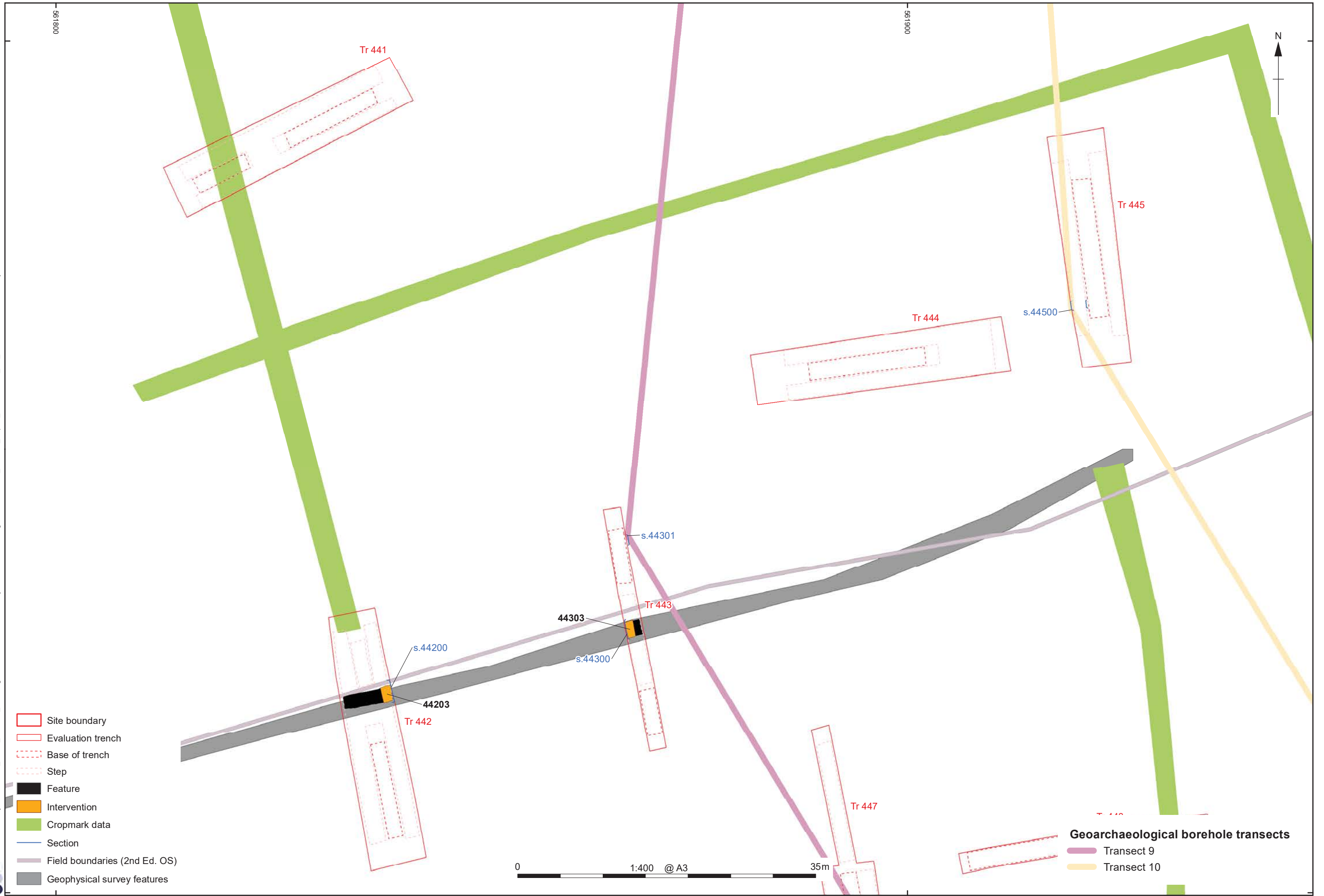

Figure 33: Plan of Trenches 441-445

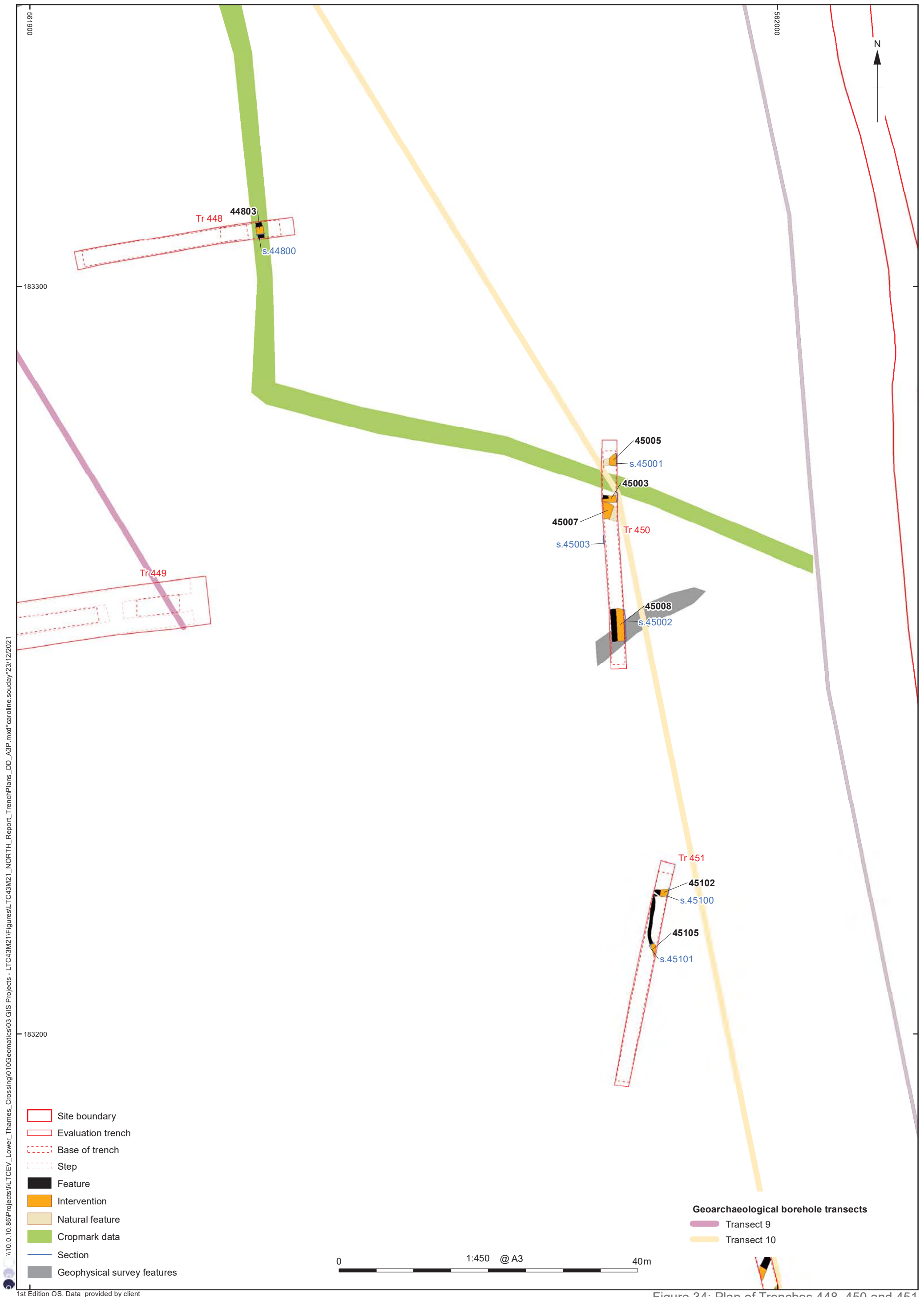

Figure 34: Plan of Trenches 448, 450 and 451

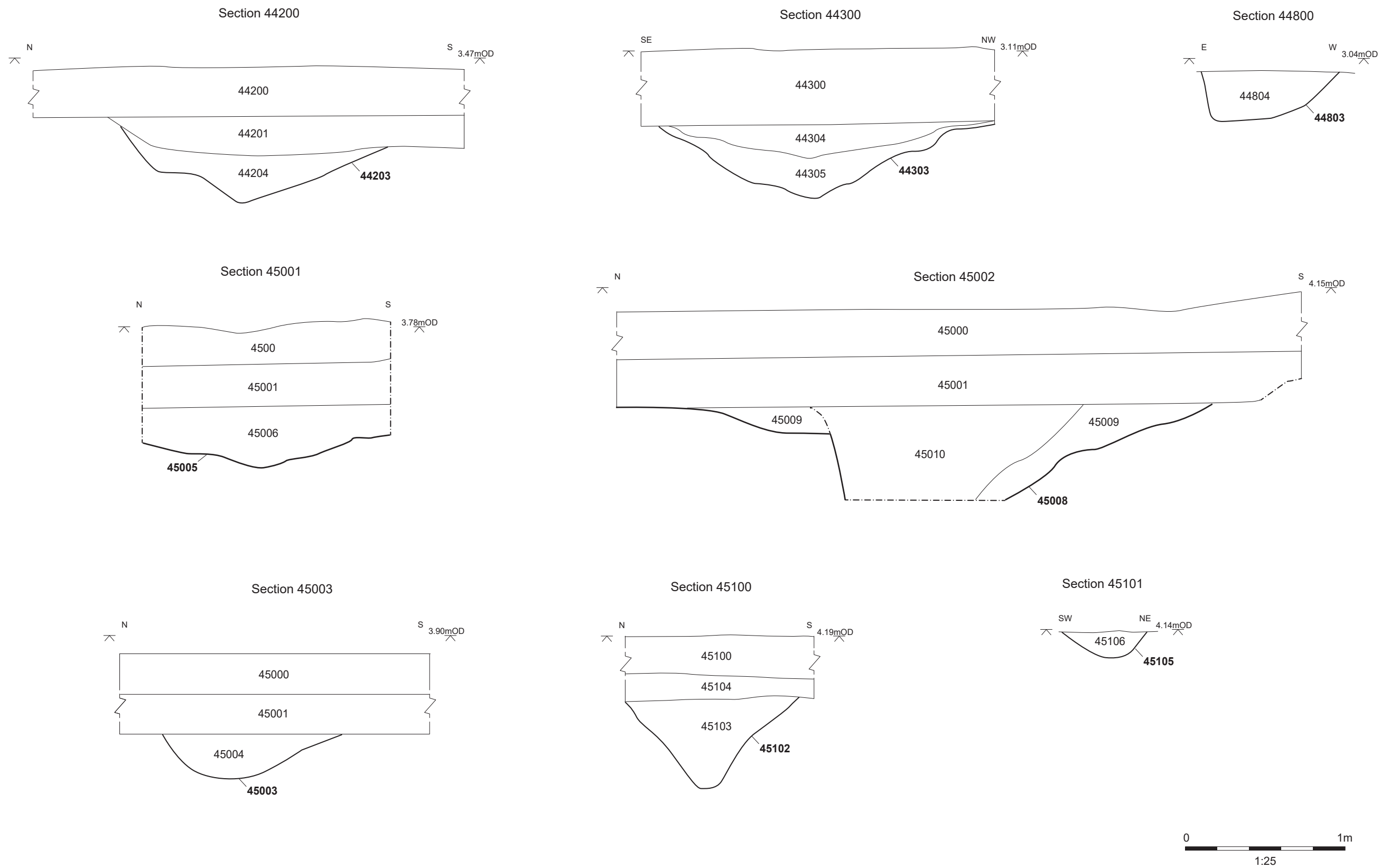
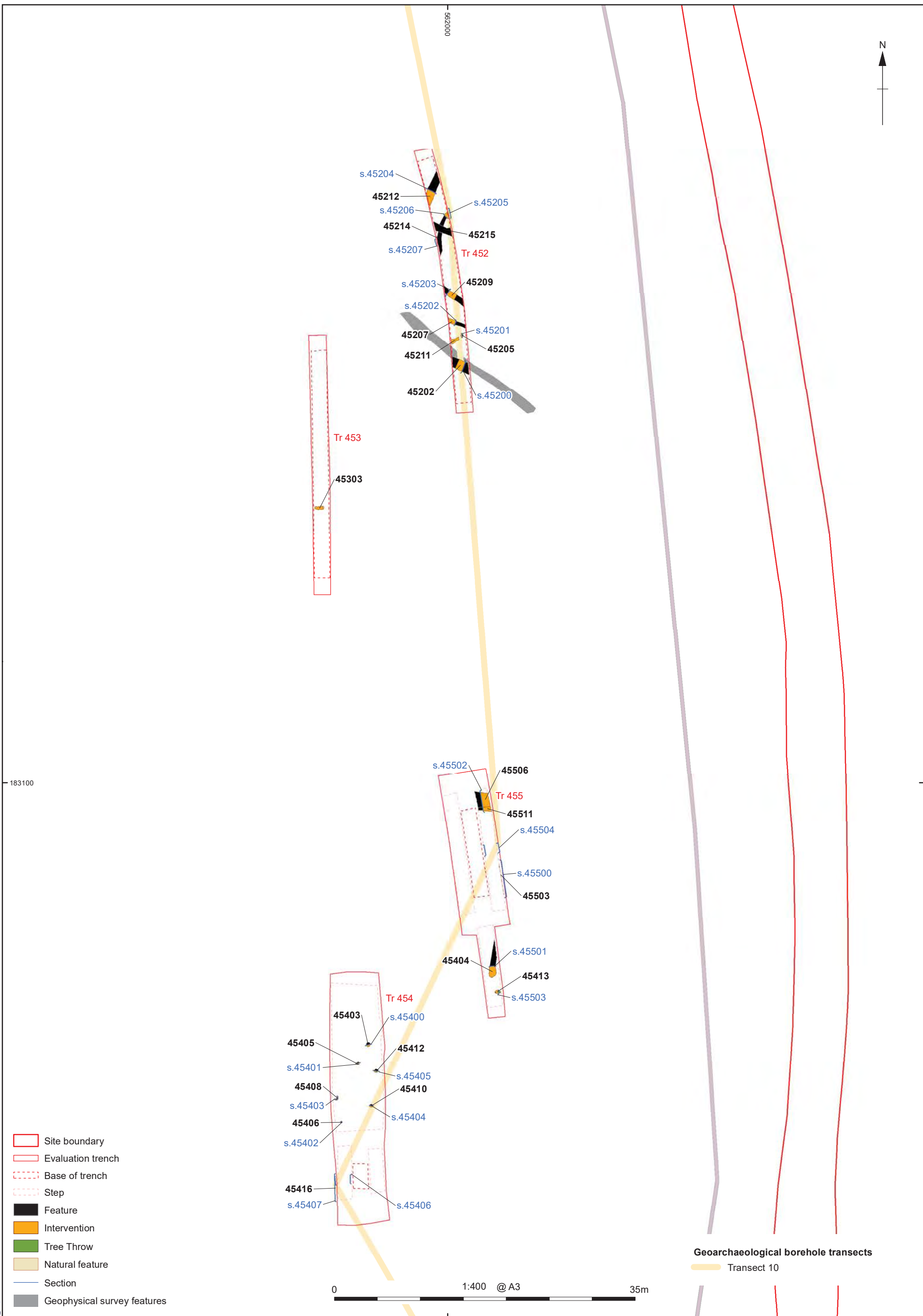

Figure 35: Sections (Trenches 442, 443, 448, 450 and 451)



Geoarchaeological borehole transects
Transect 10

Figure 36: Plan of Trenches 452-455

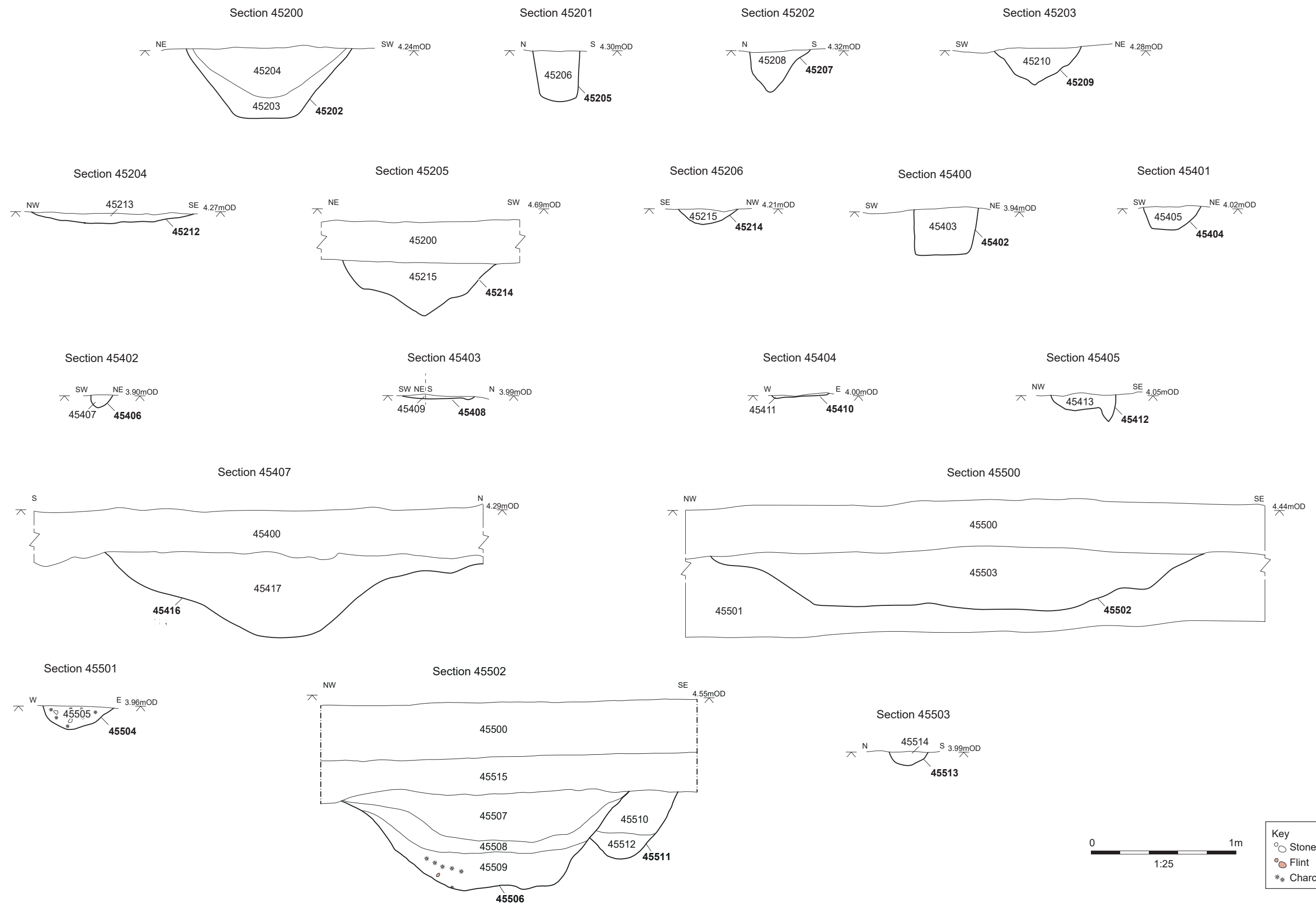

Figure 37: Sections (Trenches 452, 454 and 455)

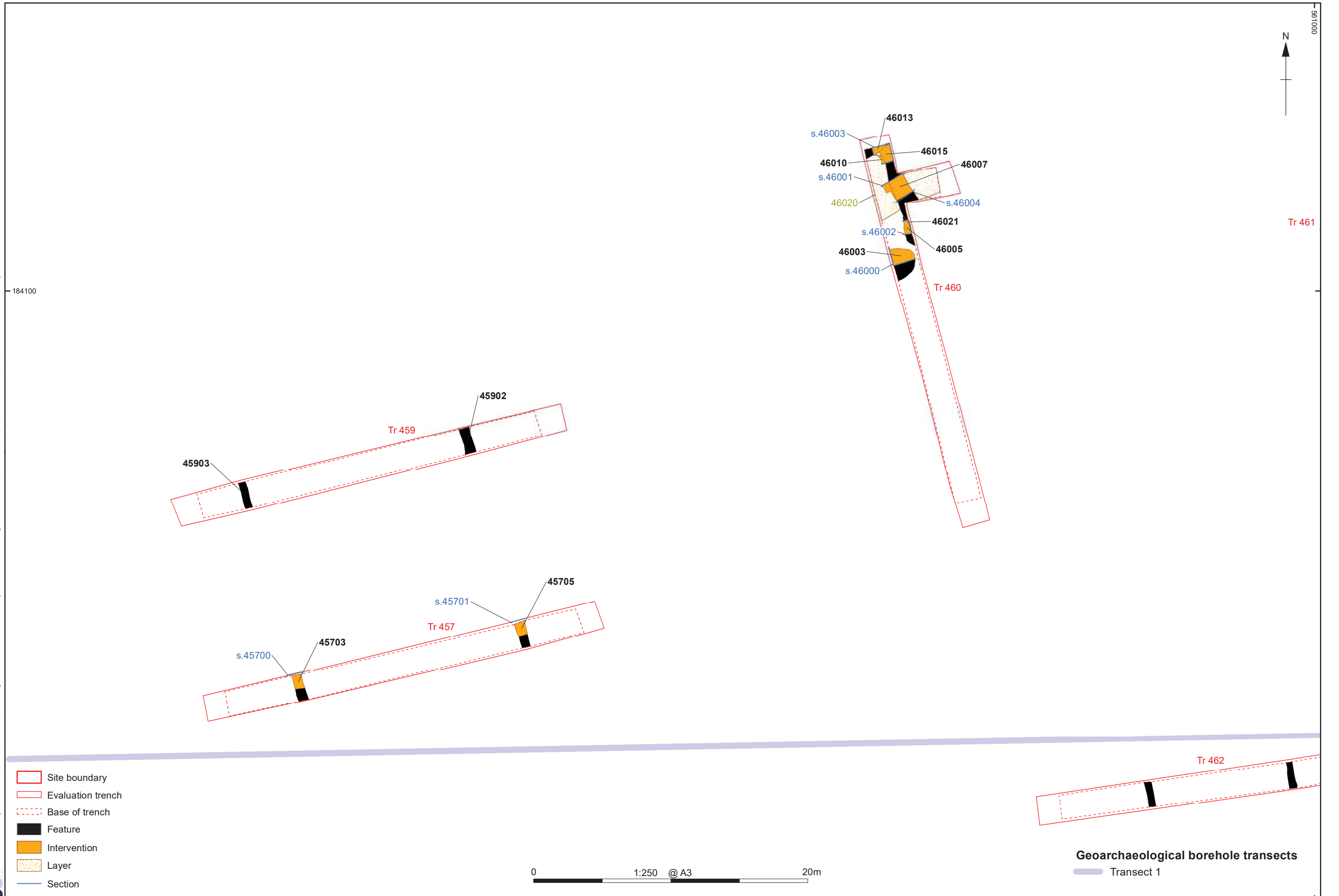
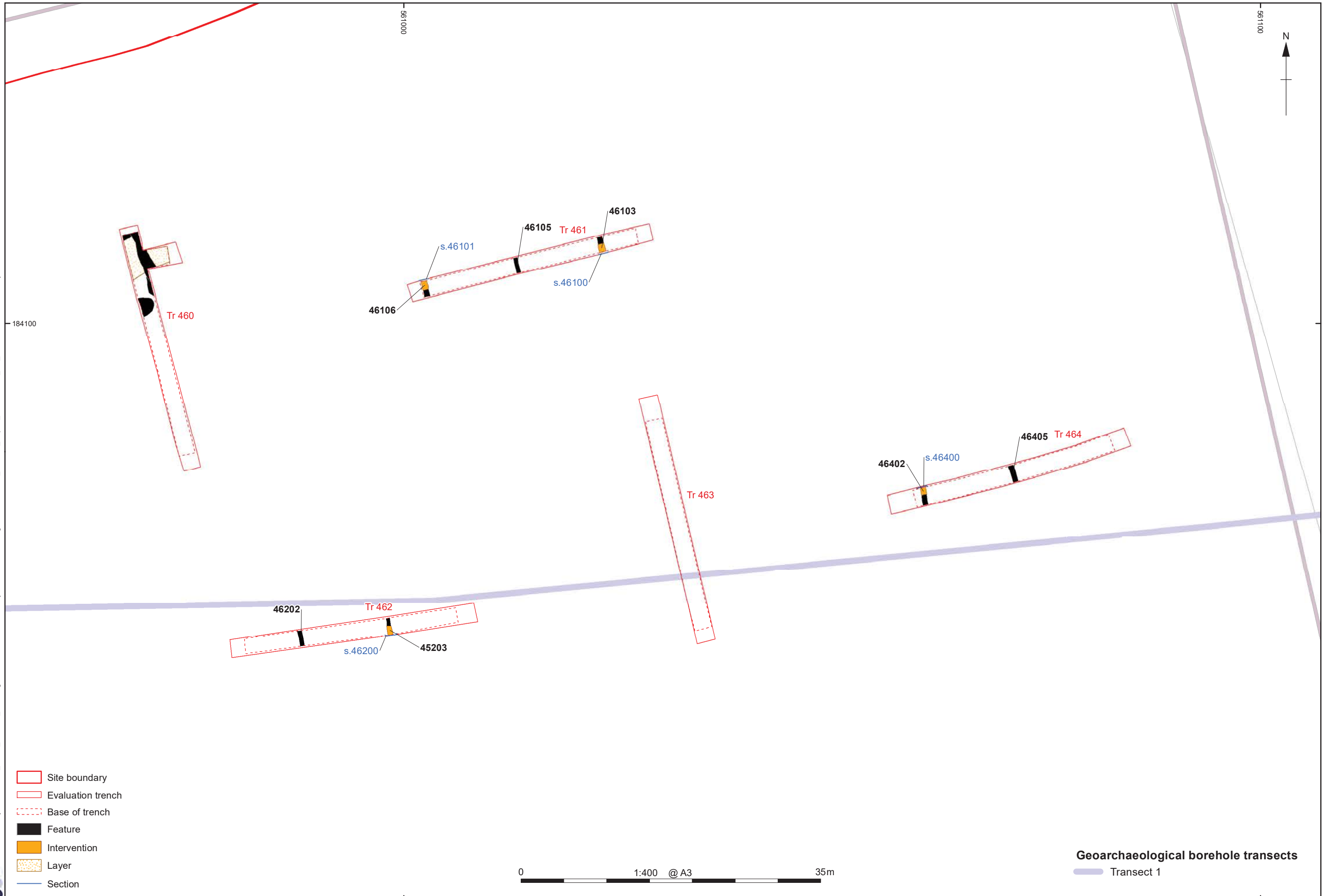

Figure 38: Plan of Trenches 457 and 459-460







\\10.0.10.86\Projects\Lower_Thames_Crossing\010\Geomatics\03 GIS Projects - LTC43M21\Figures\LTC43M21_NORTH_Report_TrenchPlans_DD_A3L.mxd*caroline.souday*23/12/2021

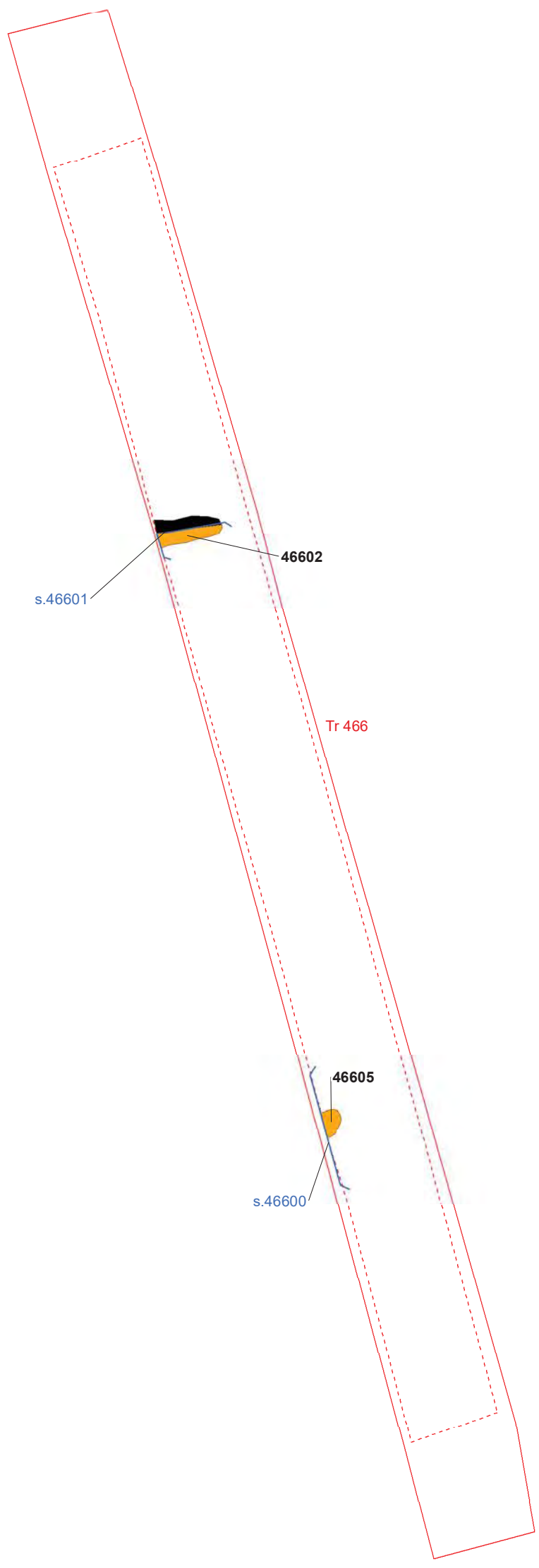

Geoarchaeological borehole transects
Transect 1

Figure 39: Plan of Trenches 461-464



-  Site boundary
-  Evaluation trench
-  Base of trench
-  Feature
-  Intervention
-  Section



\\10.0.10.86\Projects\TCEV_Lower_Themes_Crossing\010\Geomatics\03 GIS Projects - LTC43M21\Figures\LTC43M21_NORTH_Report_TrenchPlans_DD_A3P.mxd*caroline.souday*23/12/2021

1st Edition OS. Data provided by client

Figure 40: Plan of Trench 466

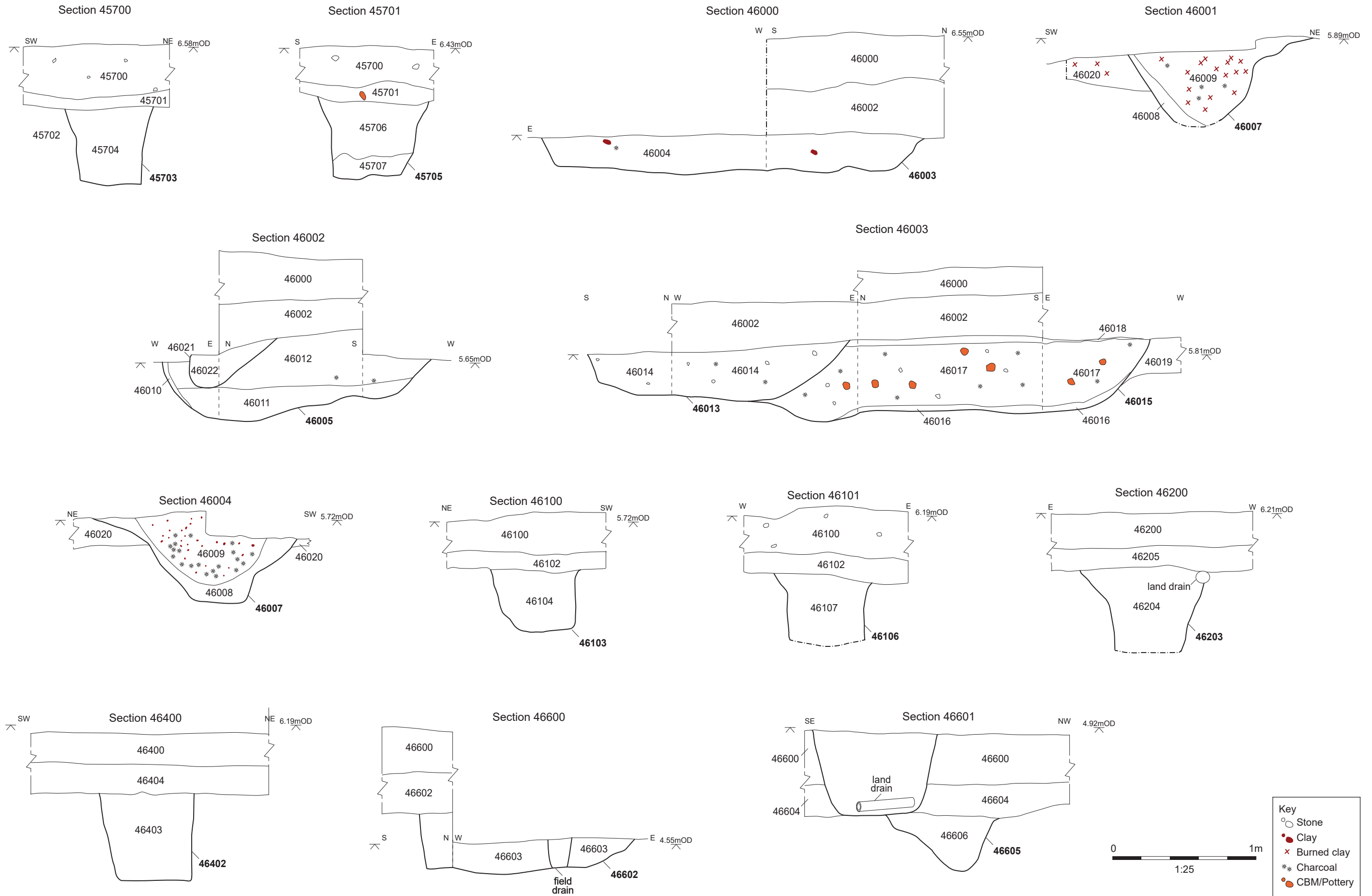

Figure 41: Sections (Trenches 457, 460, 461, 462, 464 and 466)

\\10.0.10.86\Projects\Lower_Thames_Crossing\010Geomatics\03 GIS Projects - LTC43M2\Figures\LTC43M21_NORTH_Report_TrenchPlans_DD_A3L.mxd*caroline.souday*23/12/2021

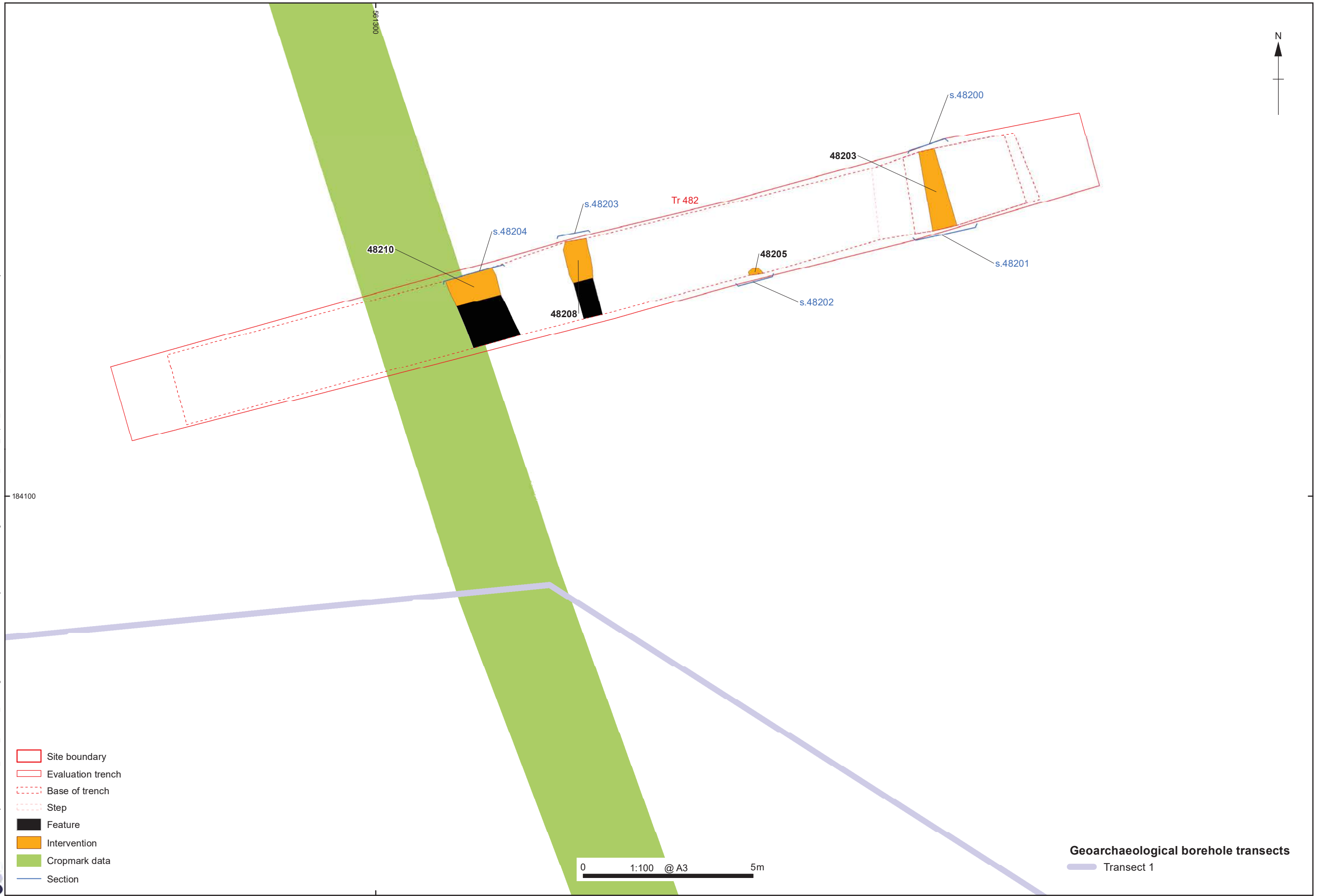

Figure 42: Plan of Trenches 482

\\10.0.10.86\Projects\TCEV_Lower_Thames_Crossing\010\Geomatics\03 GIS Projects - LTC43M21\Figures\LTC43M21_NORTH_Report_TrenchPlans_DD_A3L.mxd*caroline.souday*23/12/2021

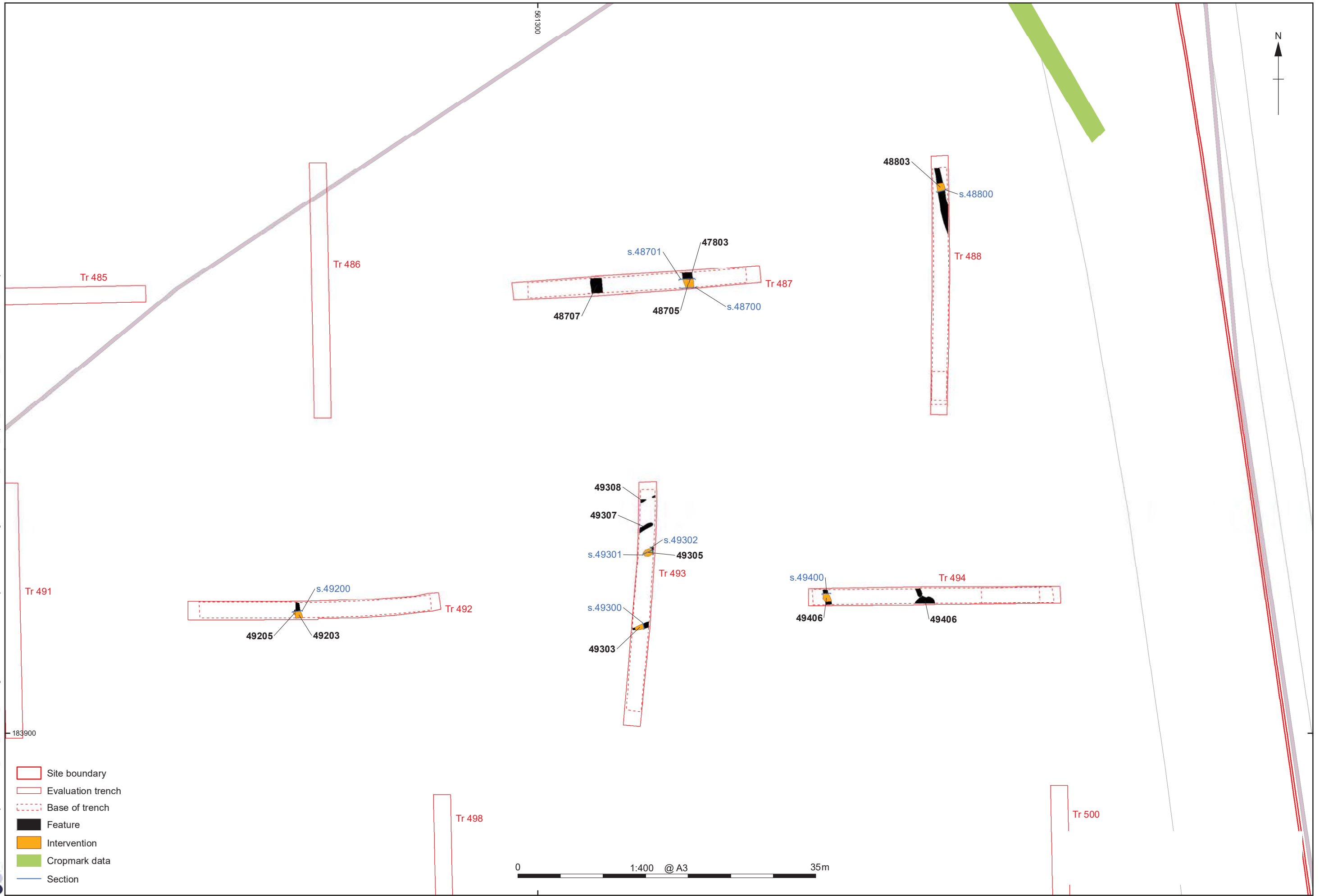
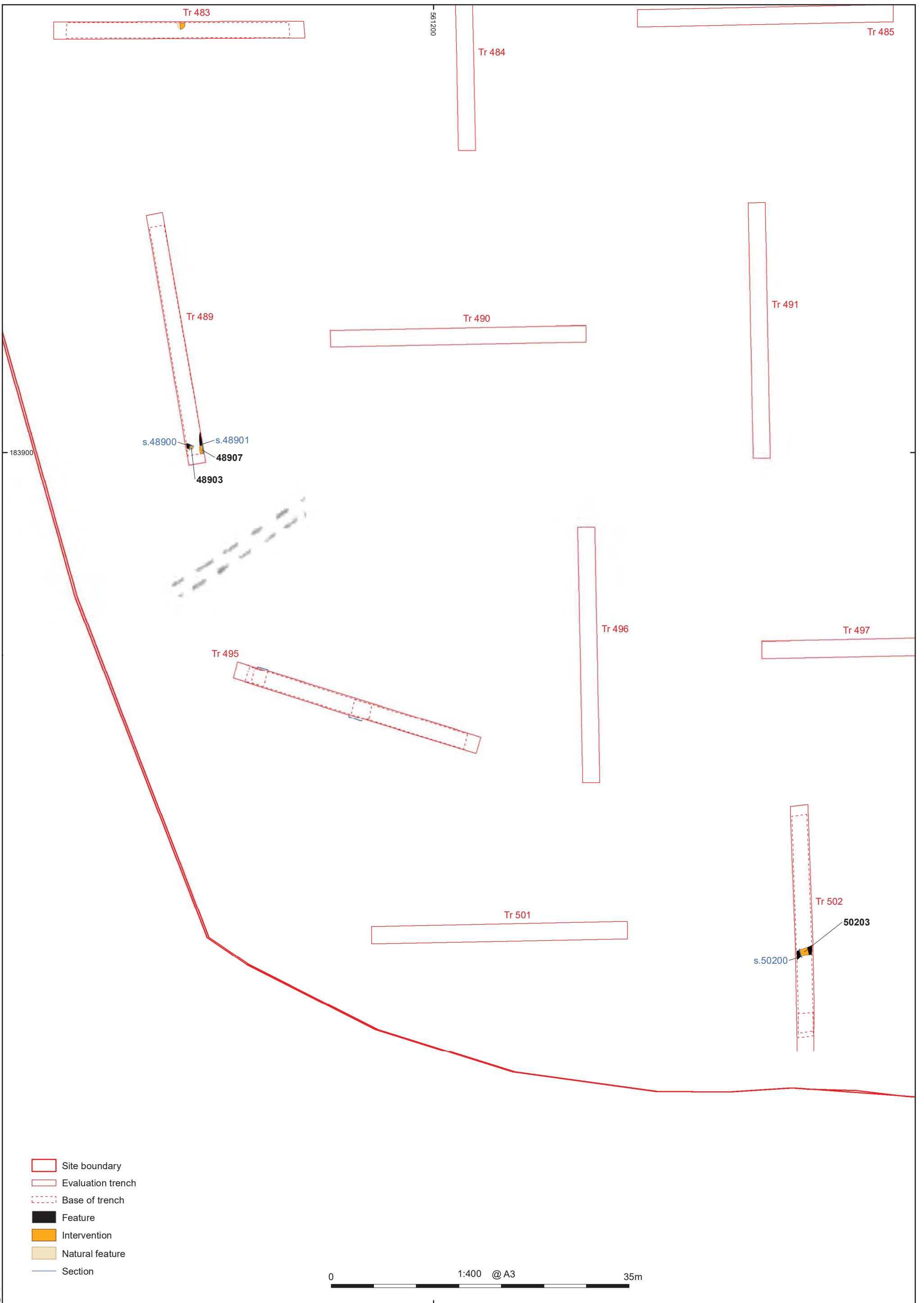

Figure 43: Plan of Trenches 487-488 and 492-494



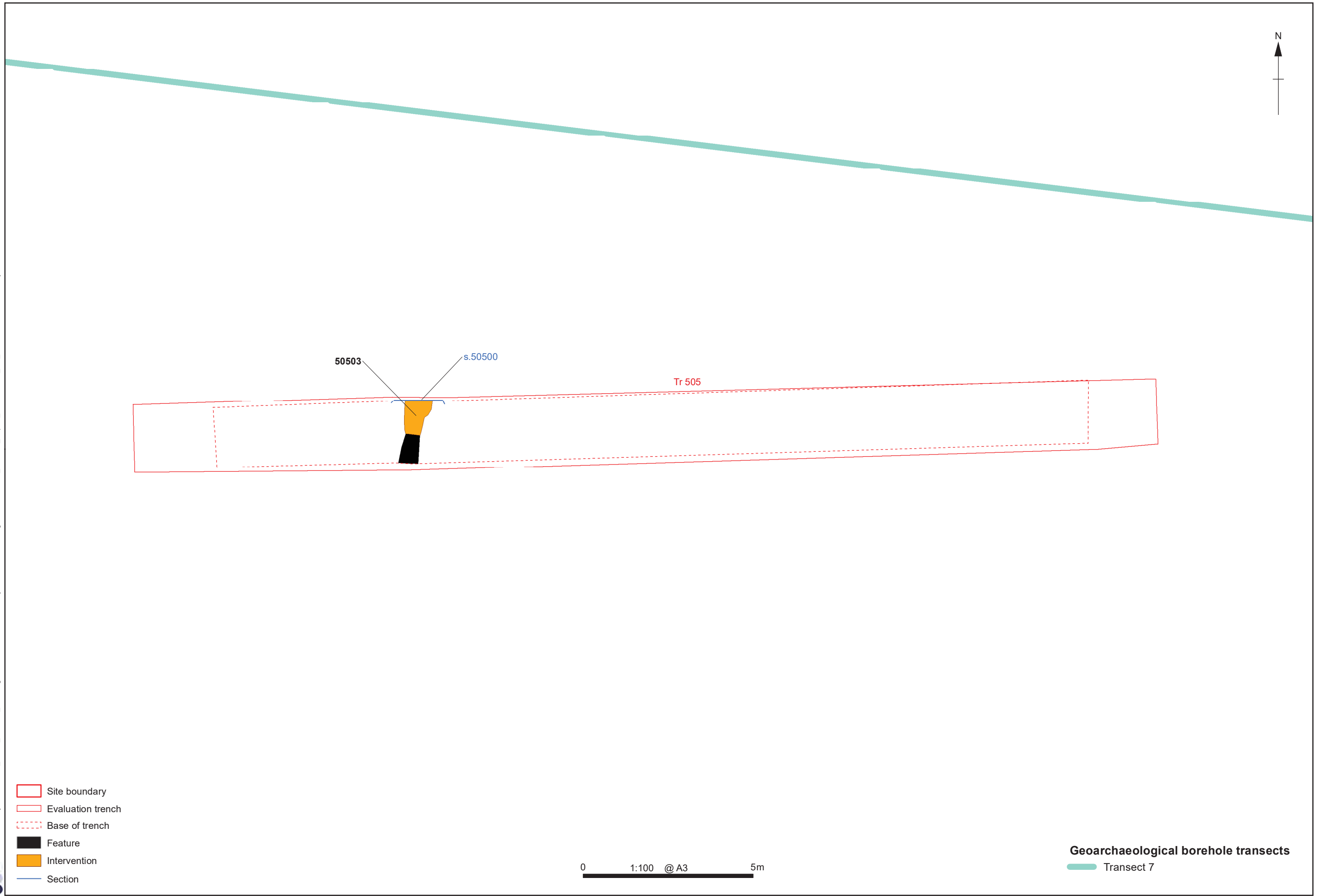

Figure 45: Plan of Trench 505

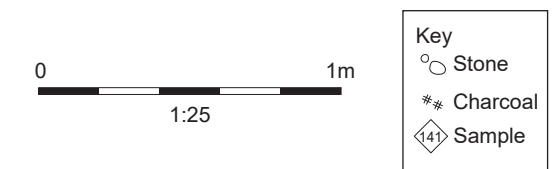
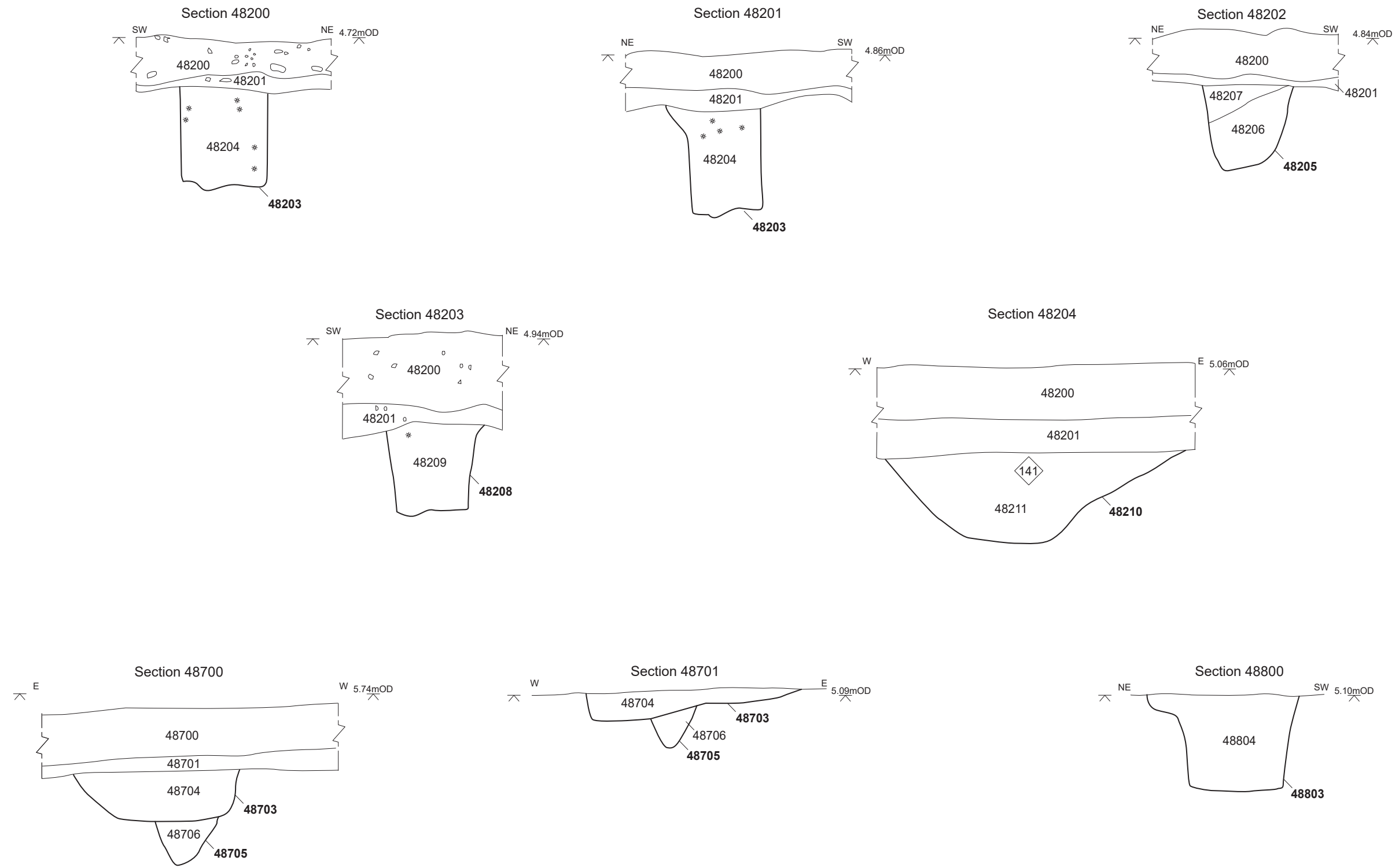

Figure 46: Sections (Trenches 482, 487 and 488)

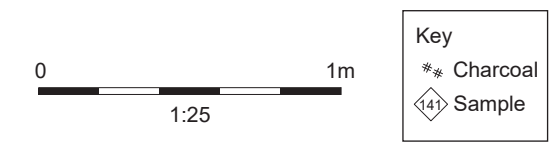
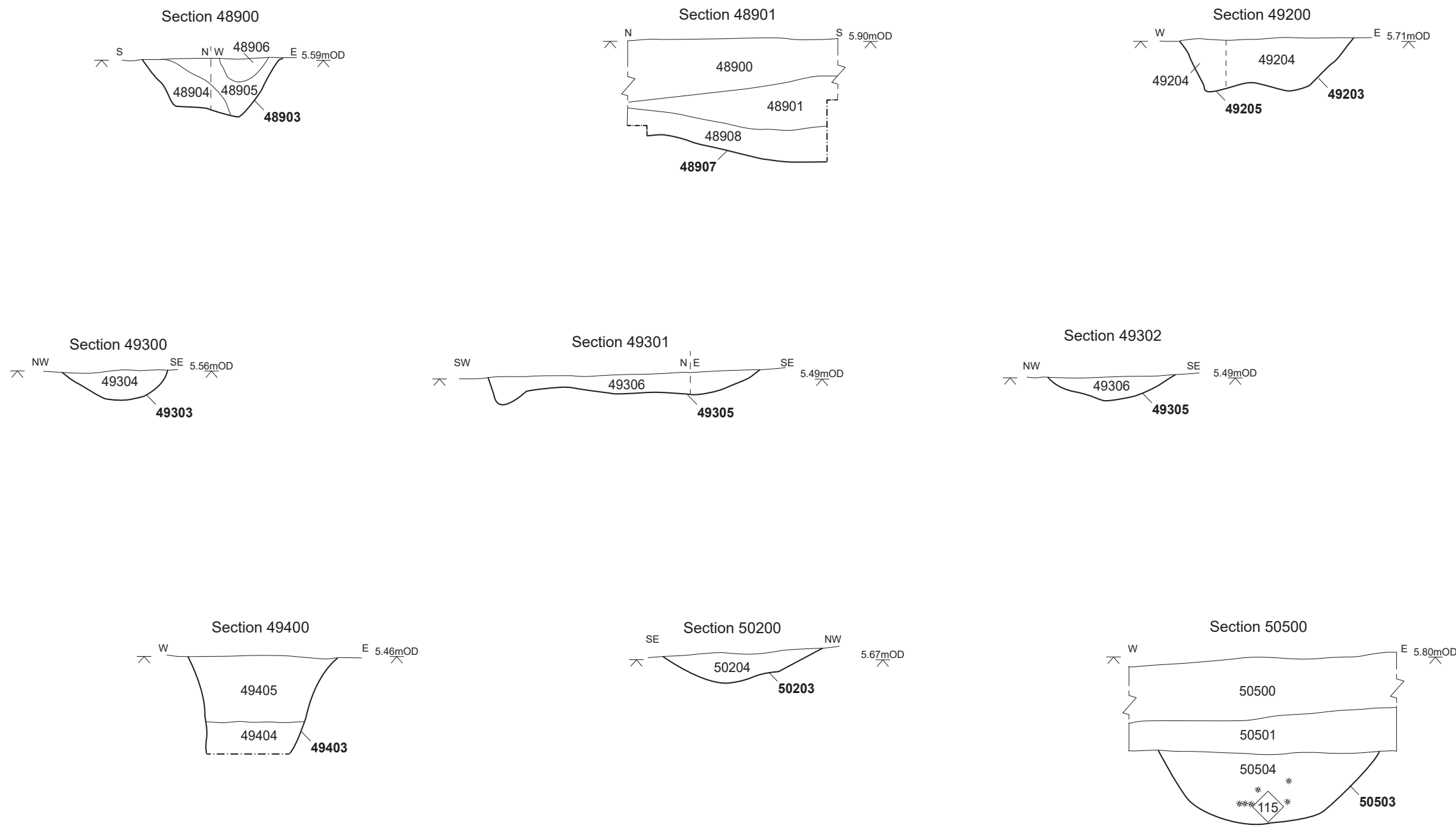

Figure 47: Sections (Trenches 489, 492, 493, 494, 502 and 505)

\\10.0.10.86\Projects\ILTCEV_Lower_Thames_Crossing\010\Geomatics\03 GIS Projects - LTC43M2\Figures\LTC43M21_NORTH_Report_TrenchPlans_DD_A3L.mxd*caroline.souday*23/12/2021

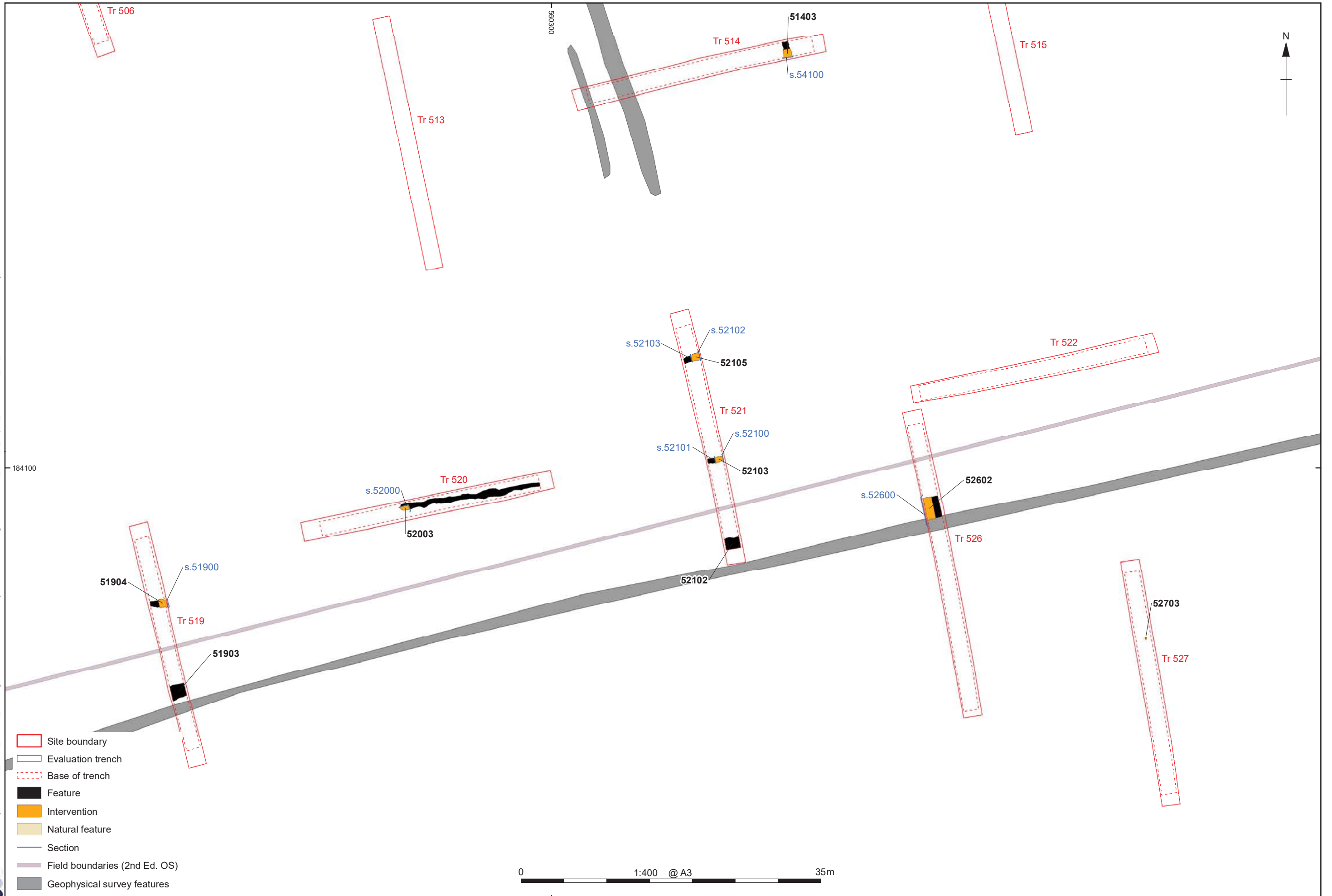

Figure 48: Plan of Trenches 513-514, 519-521 and 526-527

\\10.0.10.86\Projects\Lower_Thames_Crossing\010\Geomatics\GIS\Projects - LTC43M21\Figures\LTC43M21_NORTH_Report_TrenchPlans_DD_A3L.mxd*caroline.souday*23/12/2021

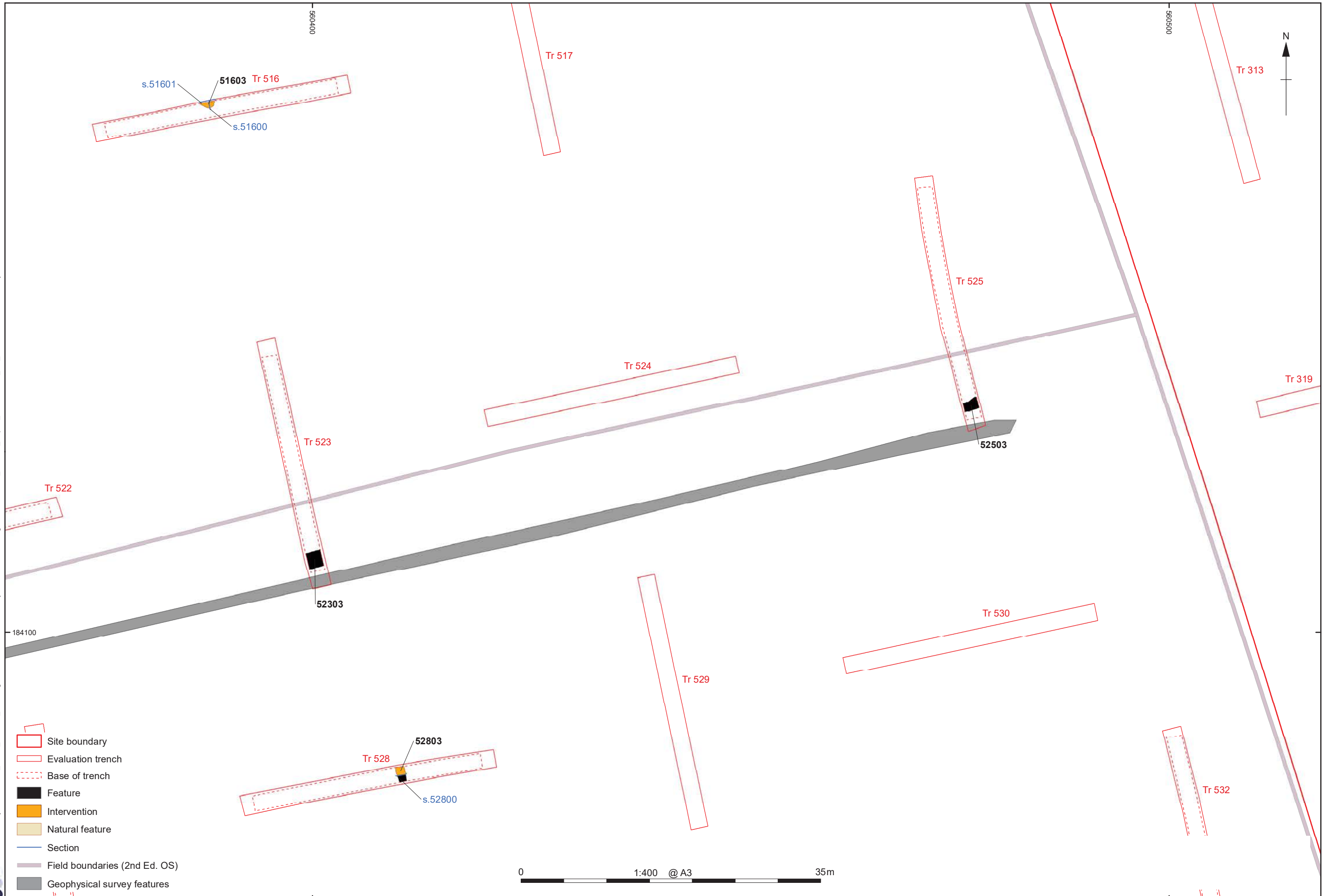
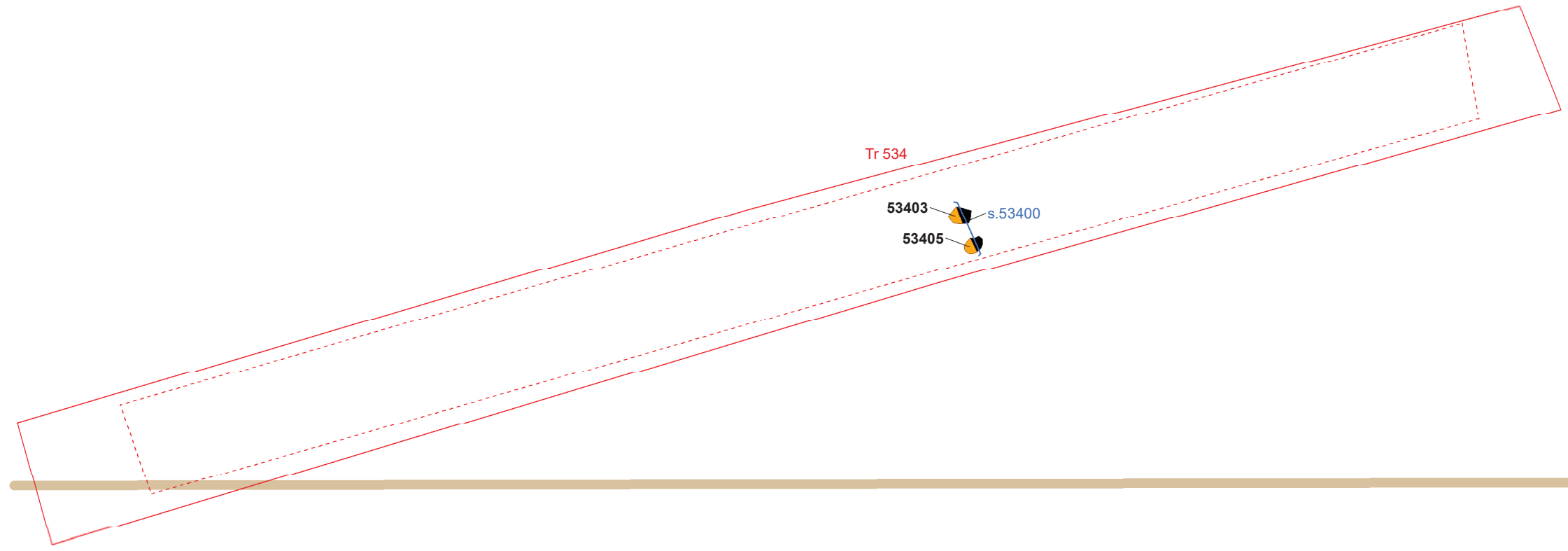







Figure 49: Plan of Trenches 516, 523-525 and 528-530

\\10.0.10.86\Projects\ILTCEV_Lower_Thames_Crossing\010Geomatics\03 GIS Projects - LTC43M2\Figures\LTC43M21_NORTH_Report_Trench\Plans_DD_A3L.mxd*caroline.souday*23/12/2021

001.096



-  Site boundary
-  Evaluation trench
-  Base of trench
-  Feature
-  Intervention
-  Section

0 1:100 @ A3 5m

Geoarchaeological borehole transects
 Transect 6

Figure 50: Plan of Trench 534

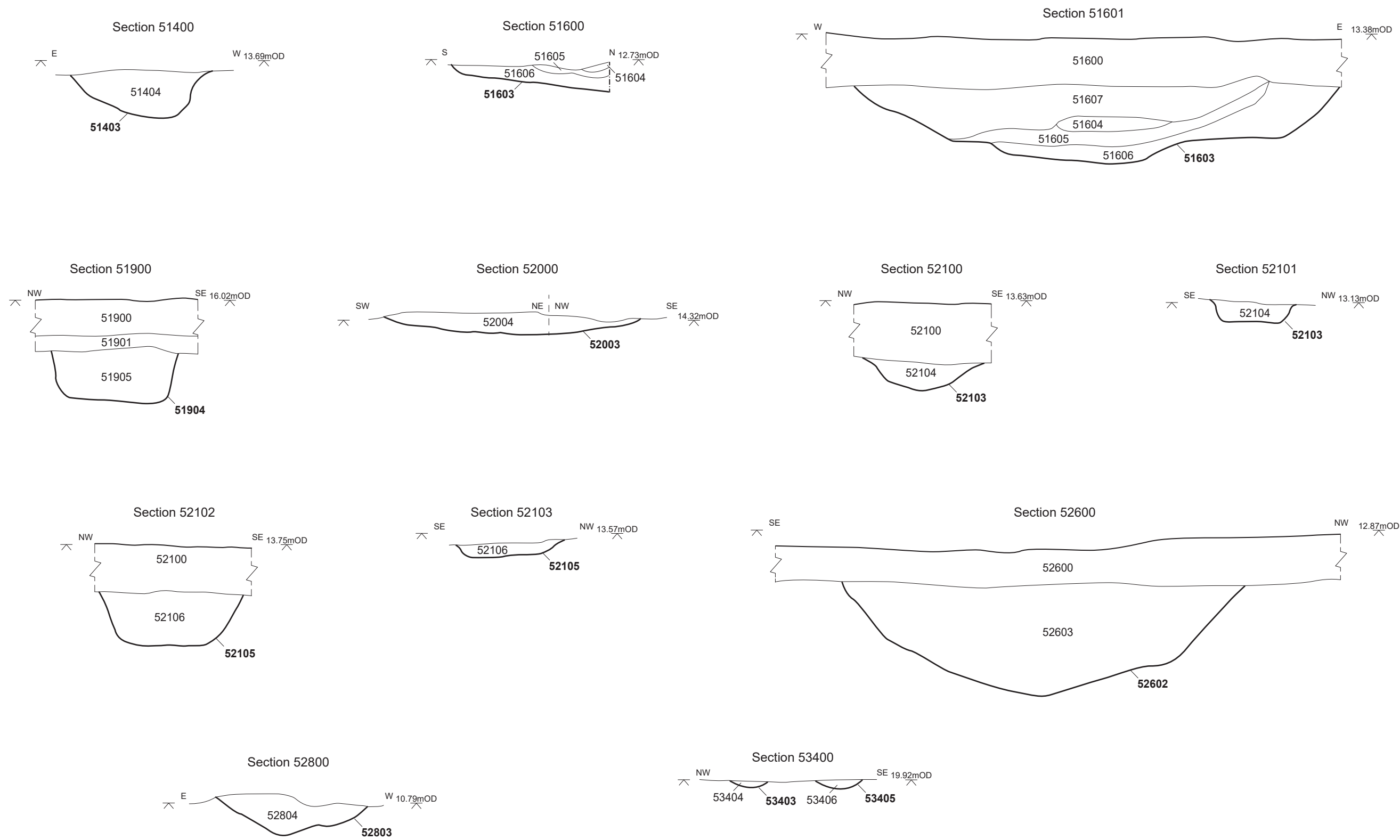

Figure 51: Sections (Trenches 514, 516, 519, 520, 521, 526, 528 and 534)

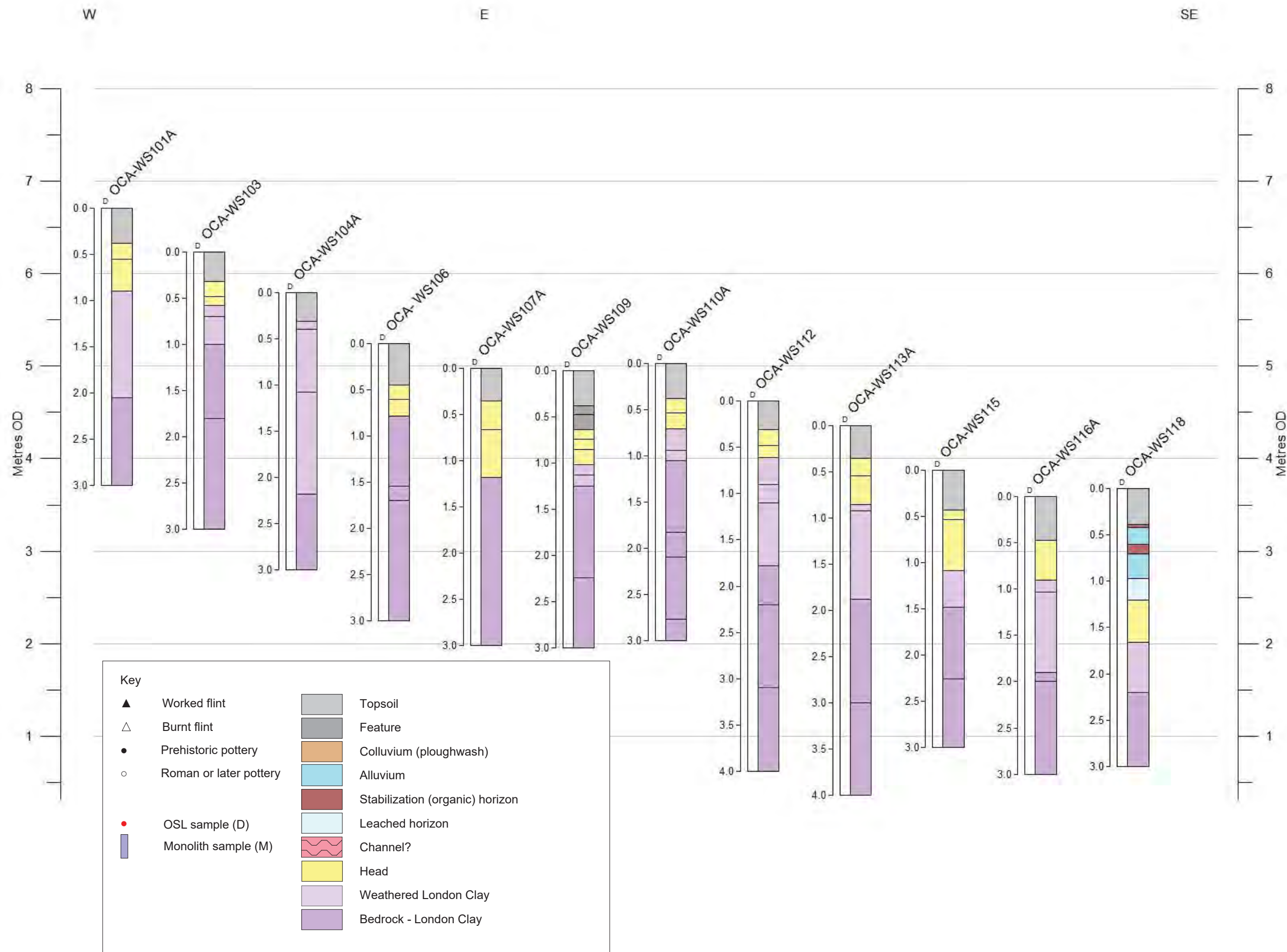

Figure 52: Geoarchaeological transect 1: Boreholes WS101-WS118

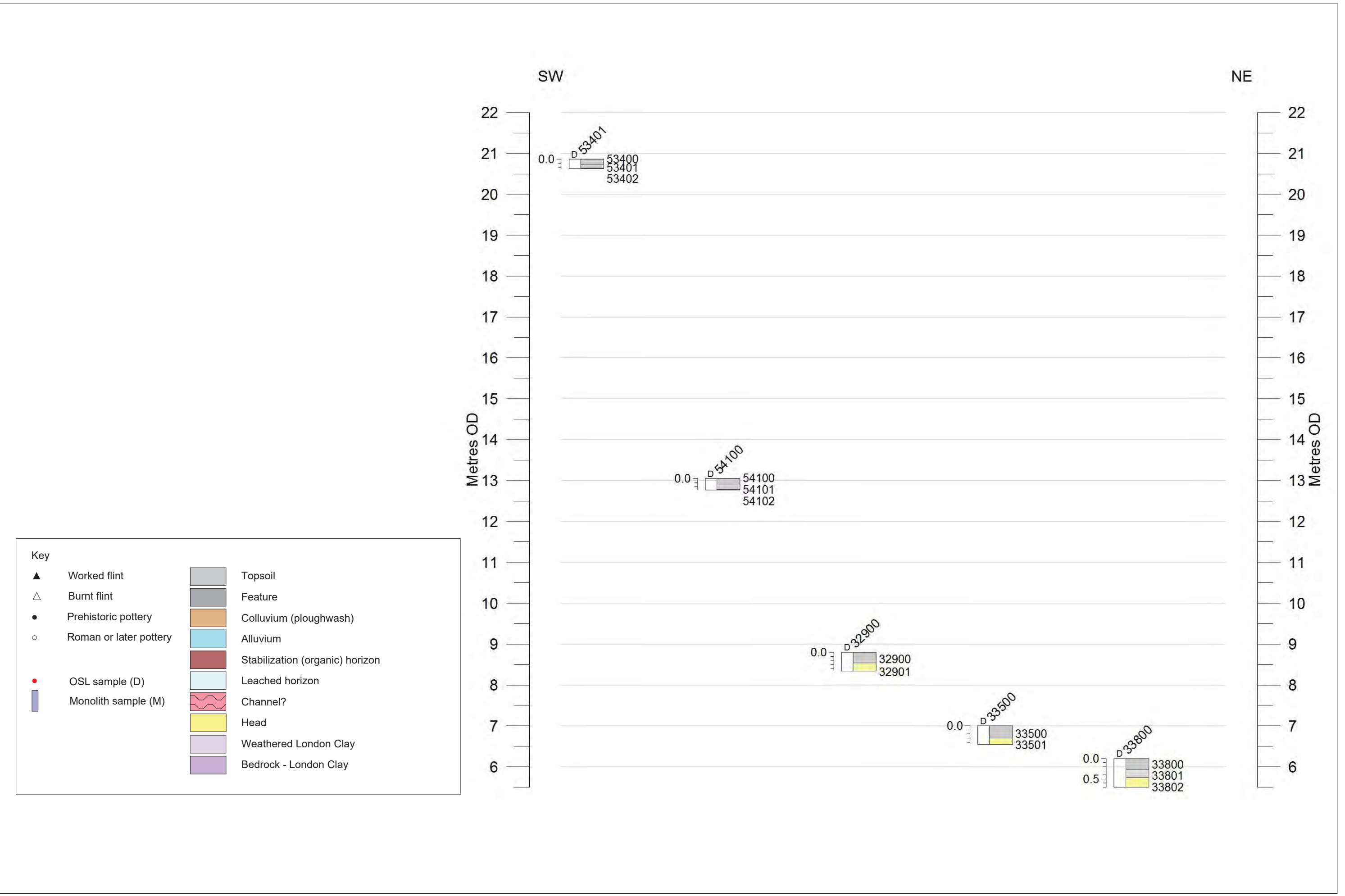

Figure 53: Geoarchaeological transect 6: Trenches 534, 541, 392, 335 and 338

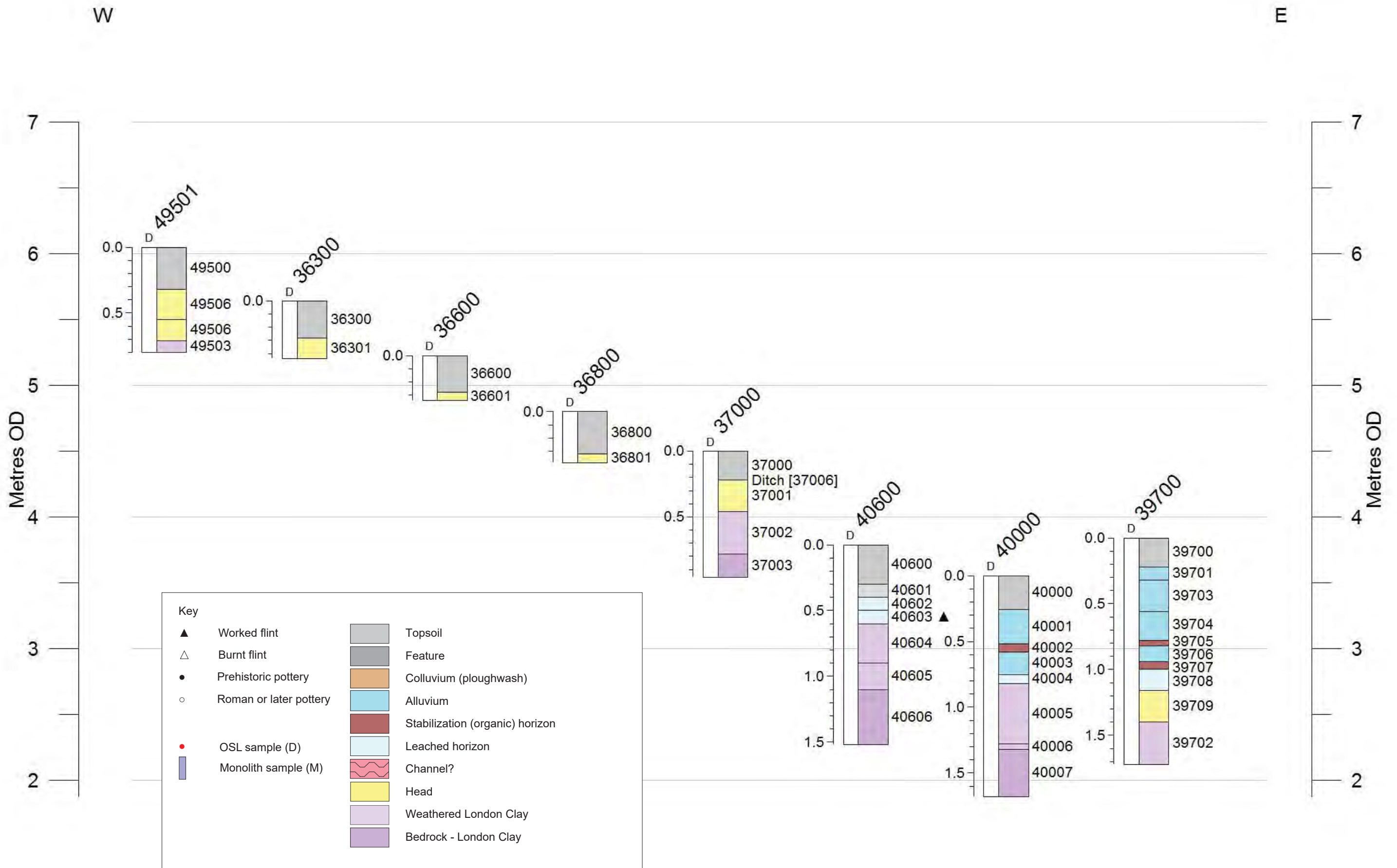
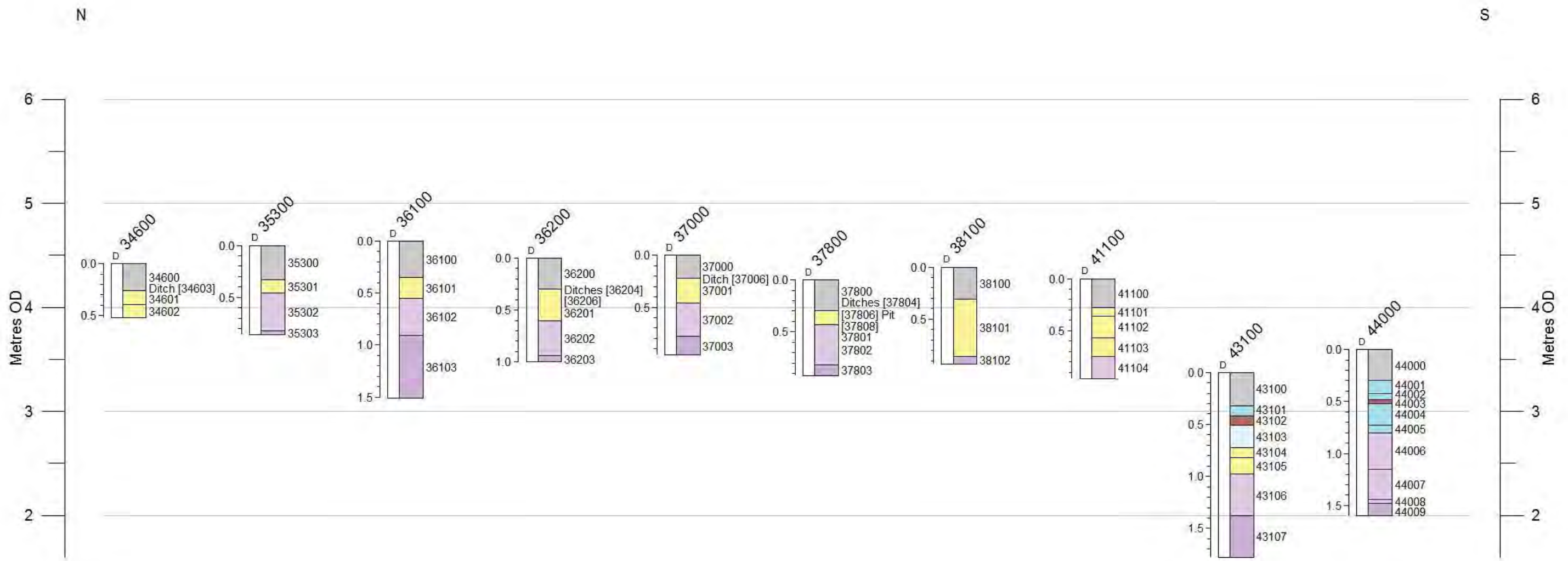
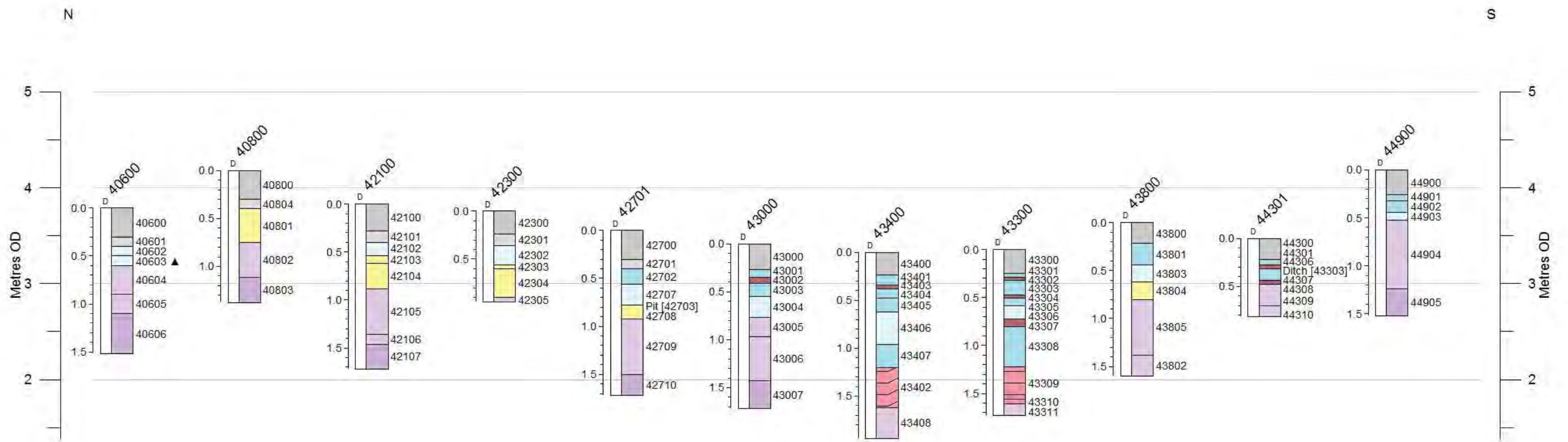

Figure 54: Geoaerchaeological transect 7: Trenches 495, 363, 366, 368, 370, 406, 400 and 397



Key			
▲	Worked flint	■	Topsoil
△	Burnt flint	■	Feature
●	Prehistoric pottery	■	Colluvium (ploughwash)
○	Roman or later pottery	■	Alluvium
●	OSL sample (D)	■	Stabilization (organic) horizon
■	Monolith sample (M)	■	Leached horizon
		■	Channel?
		■	Head
		■	Weathered London Clay
		■	Bedrock - London Clay

Figure 55: Geoaerchaeological transect 8: Trenches 346, 353, 361, 362, 370, 378, 381, 411, 431, 440



Key

- | | | | |
|---|------------------------|---|---------------------------------|
| ▲ | Worked flint | ■ | Topsoil |
| △ | Burnt flint | ■ | Feature |
| ● | Prehistoric pottery | ■ | Colluvium (ploughwash) |
| ○ | Roman or later pottery | ■ | Alluvium |
| ● | OSL sample (D) | ■ | Stabilization (organic) horizon |
| ■ | Monolith sample (M) | ■ | Leached horizon |
| | | ■ | Channel? |
| | | ■ | Head |
| | | ■ | Weathered London Clay |
| | | ■ | Bedrock - London Clay |

Figure 56: Geoaerchaeological transect 9: Trenches 406, 408, 421, 423, 427, 430, 434, 433, 438, 443, and 449

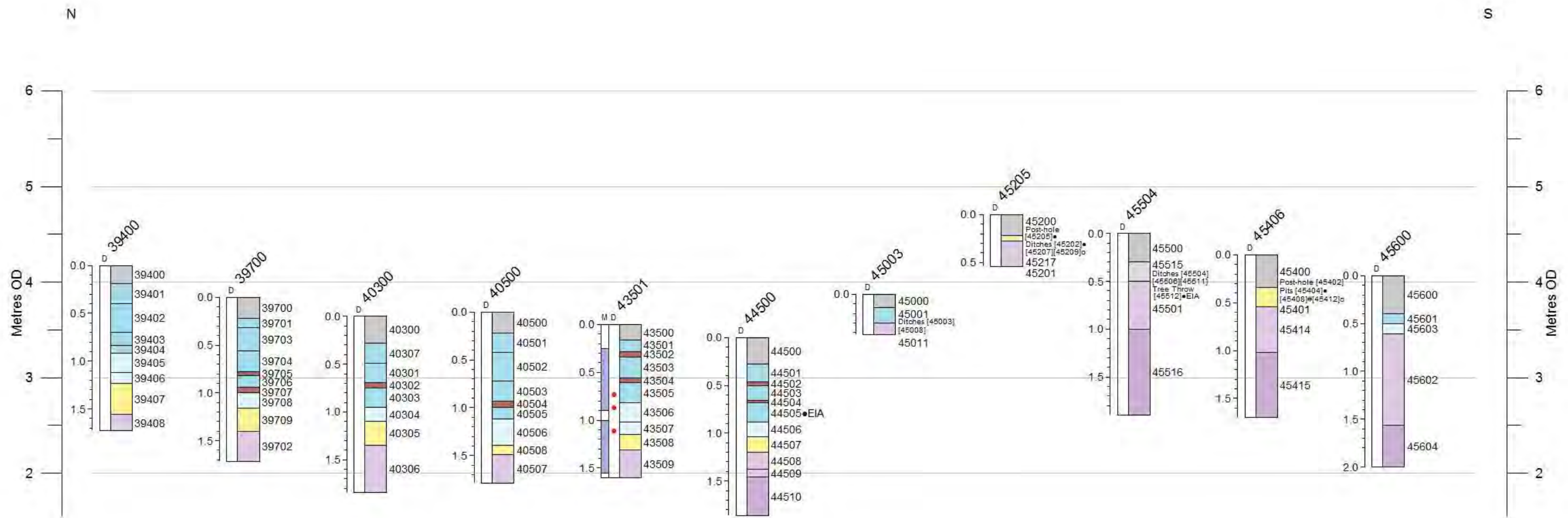

Key			
▲	Worked flint	■	Topsoil
△	Burnt flint	■	Feature
●	Prehistoric pottery	■	Colluvium (ploughwash)
○	Roman or later pottery	■	Alluvium
●	OSL sample (D)	■	Stabilization (organic) horizon
■	Monolith sample (M)	■	Leached horizon
		■	Channel?
		■	Head
		■	Weathered London Clay
		■	Bedrock - London Clay

Figure 57: Geoarchaeological transect 10: Trenches 394, 397, 403, 405, 435, 445, 450, 452, 455, 454 and 456



Key		
▲	Worked flint	Topsoil
△	Burnt flint	Feature
●	Prehistoric pottery	Colluvium (ploughwash)
○	Roman or later pottery	Alluvium
●	OSL sample (D)	Stabilization (organic) horizon
■	Monolith sample (M)	Leached horizon
		Channel?
		Head
		Weathered London Clay
		Bedrock - London Clay

Figure 58: Geoarchaeological transect 11: Trenches 431, 433, 434 and 435



Plate 1: Ditch 3069 looking north-west



Plate 2: Ditch 31112 looking south



Plate 3: Ditch 32804/32808 looking north-west



Plate 4: Ditch 32802 looking east



Plate 5: Ditch 33002 looking west



Plate 6: Gully 33006 looking north-west



Plate 7: Postholes 31109, 31110, 31105 and 31106 looking east



Plate 8: Postholes 31109 and 31106 looking north



Plate 9: Postholes 31110 and 31105 looking north



Plate 10: Postholes 31109, 31110, 31105 and 31106 looking west



Plate 11: Ditch 34107 looking north



Plate 12: Ditch 34306 looking north



Plate 13: Ditch 34603 looking north



Plate 14: Gully 35202 looking west



Plate 15: Gully 36204 looking north-west



Plate 16: Ditch 35404 looking north



Plate 17: Ditches 35902 and 35904 looking north



Plate 18: Ditch 34302 looking north-east

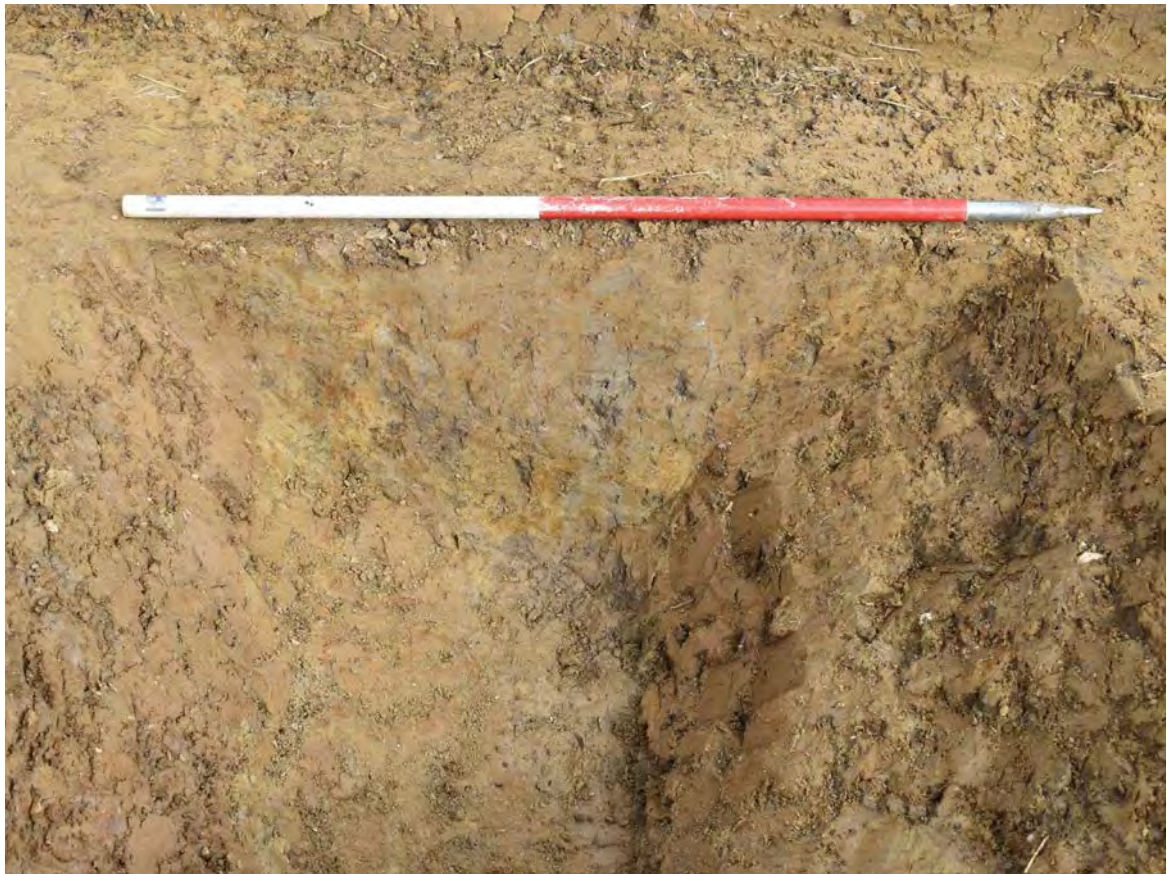

Plate 19: Ditch 35103 looking east



Plate 20: Quarry/pond 34105 looking south



Plate 21: Ditch 37402 looking west



Plate 22: Ditches 37511, 37509 and 37506



Plate 23: Ditch 37502 looking north



Plate 24: Ditch 37606 looking east



Plate 25: Pit 37808 looking north



Plate 26: Ditch 37903 looking east



Plate 27: Ditch 38202 looking north-west



Plate 28: Ditch 38206 looking north-west



Plate 29: Ditch 39003 looking north



Plate 30: Pit 39011 and posthole 39013 looking south



Plate 31: Pit 40903 looking west



Plate 32: Pit 40903 overhead

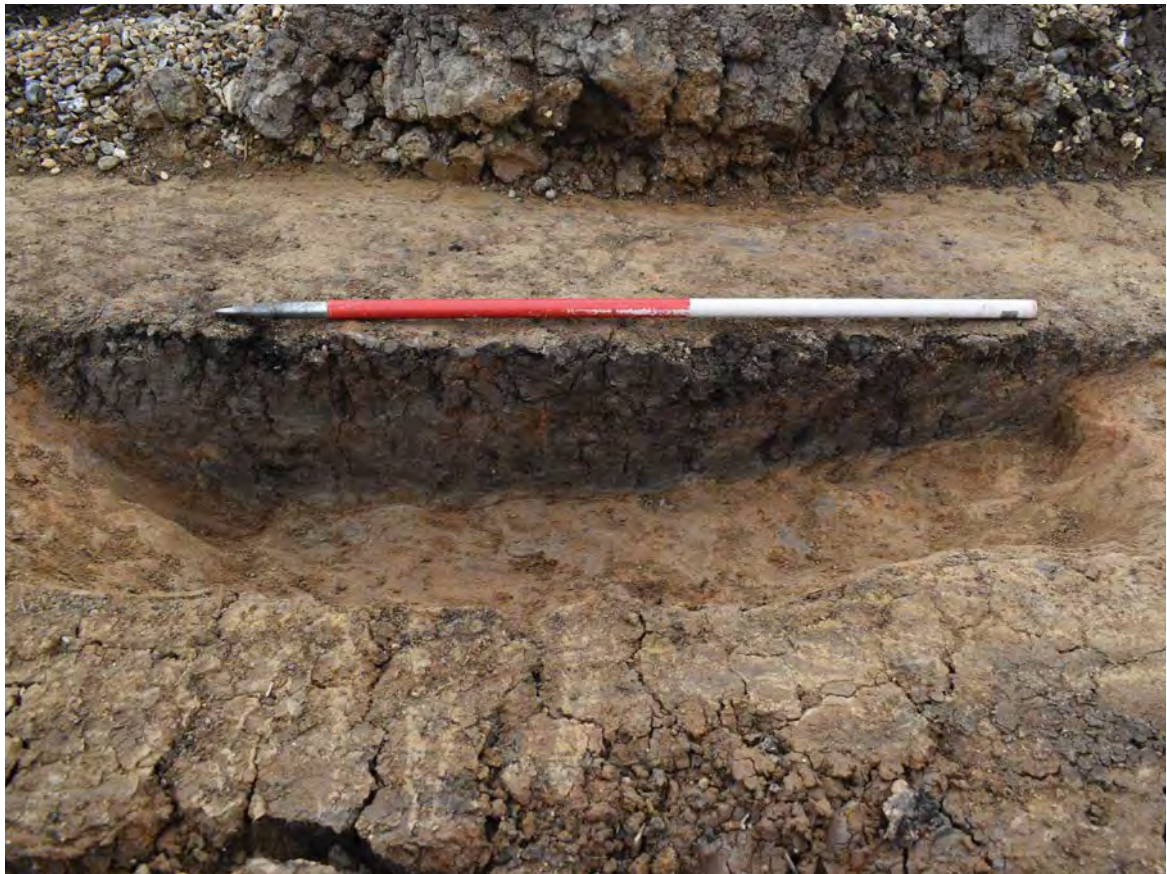

Plate 33: Pit 42703 looking east



Plate 34: Ditch 44203 looking east



Plate 35: Ditch 44803 looking south



Plate 36: Ditch 45003 looking east



Plate 37: Ditch 45008 looking east



Plate 38: Ditch 45202 looking south-east



Plate 39: Ditch 45207 looking south-east



Plate 40: Ditch 45209 looking north-west



Plate 41: Posthole 45205 looking east



Plate 42: Posthole 45402 looking north-west



Plate 43: Posthole 45404 looking north-west



Plate 44: Posthole 45412 looking north-west



Plate 45: Posthole 45406 looking north-east



Plate 46: Ditches 45511 and 45506 looking north-east



Plate 47: Tree throw 45513 looking north-east



Plate 48: Ditch 45703 looking north-west



Plate 49: Ditch 45705 looking north-west



Plate 50: Ditch 46106 looking north



Plate 51: Ditch 46203 looking south



Plate 52: Hearth 46003 looking south-west



Plate 53: Pit 46005 looking south



Plate 54: Ditch 46007 looking north-west



Plate 55: Ditches 46007/46015 and 46013 looking south



Plate 56: Ditches 46013 and 46015 looking east



Plate 57: Occupation deposit 46019/46020 looking NNE



Plate 58: Ditch terminus 46602 looking east



Plate 59: Ditch 48210 looking north



Plate 60: Ditches 48703 and 48705 looking south



Plate 61: Ditch terminus 49305 looking north-east



Plate 62: Possible hearth or tree throw 51603 looking west



Plate 63: Ditch 52602 looking west



Plate 64: Ditch 51904 looking north-east



Plate 65: Ditch 52103 looking north-east



Plate 66: Transect 6, Trench 338, Section 33800 – Sedimentary sequence within dry valley base on western slopes of Mar Dyke valley



Plate 67: Transect 7, Trench 397, Section 39700 – Intercalated alluvium and stabilisation horizons overlying leached horizon on Mar Dyke floodplain to the eastern side of LP 45C

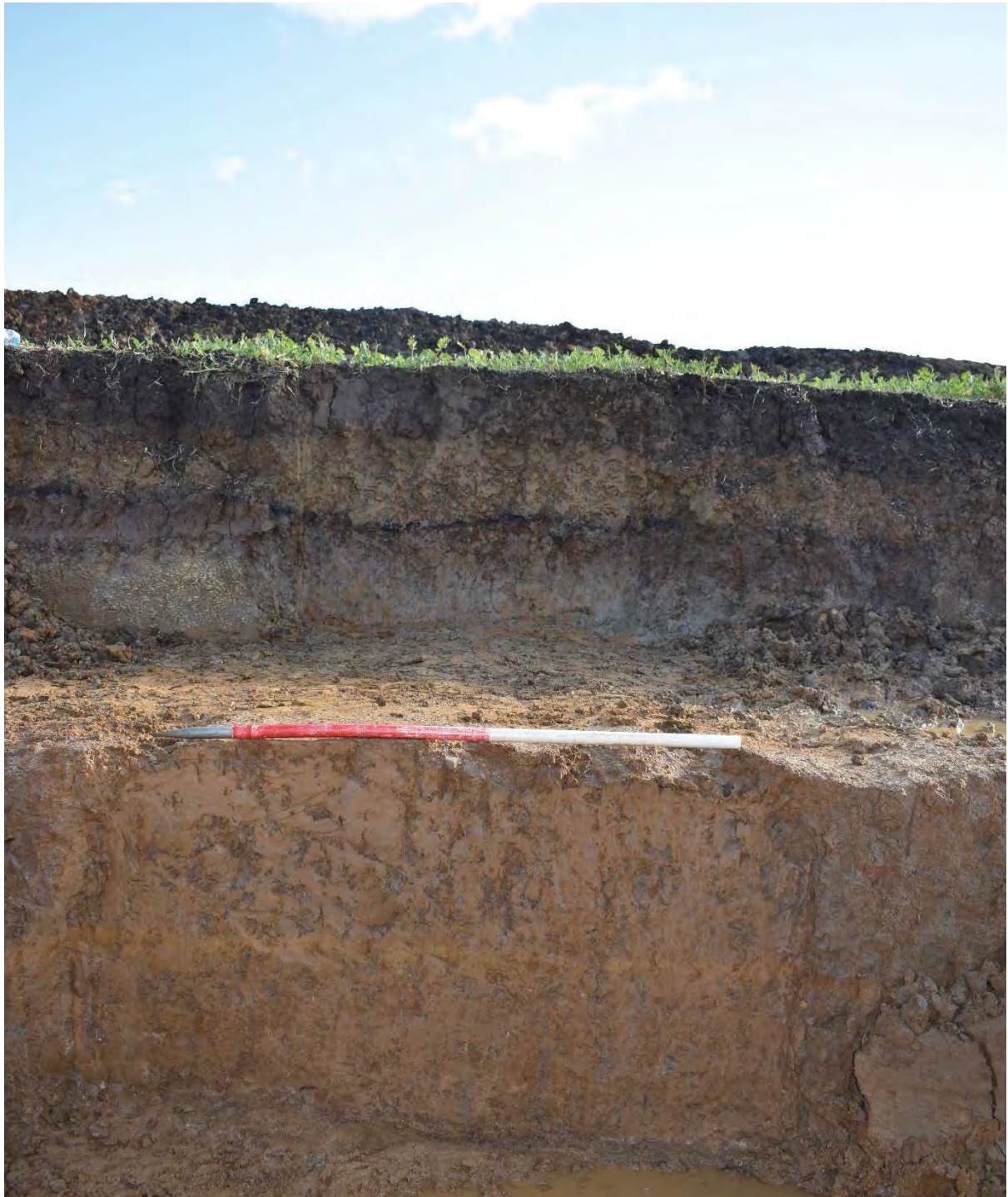

Plate 68: Transect 7, Trench 400, Section 40000 - Intercalated alluvium and stabilisation horizons overlying leached horizon on Mar Dyke floodplain. Section location is within faint palaeochannel identified on LiDAR imagery



Plate 69: Transect 8, Trench 362, Section 36200 – Head and London Clay deposits occurring throughout northern Mar Dyke valley promontory

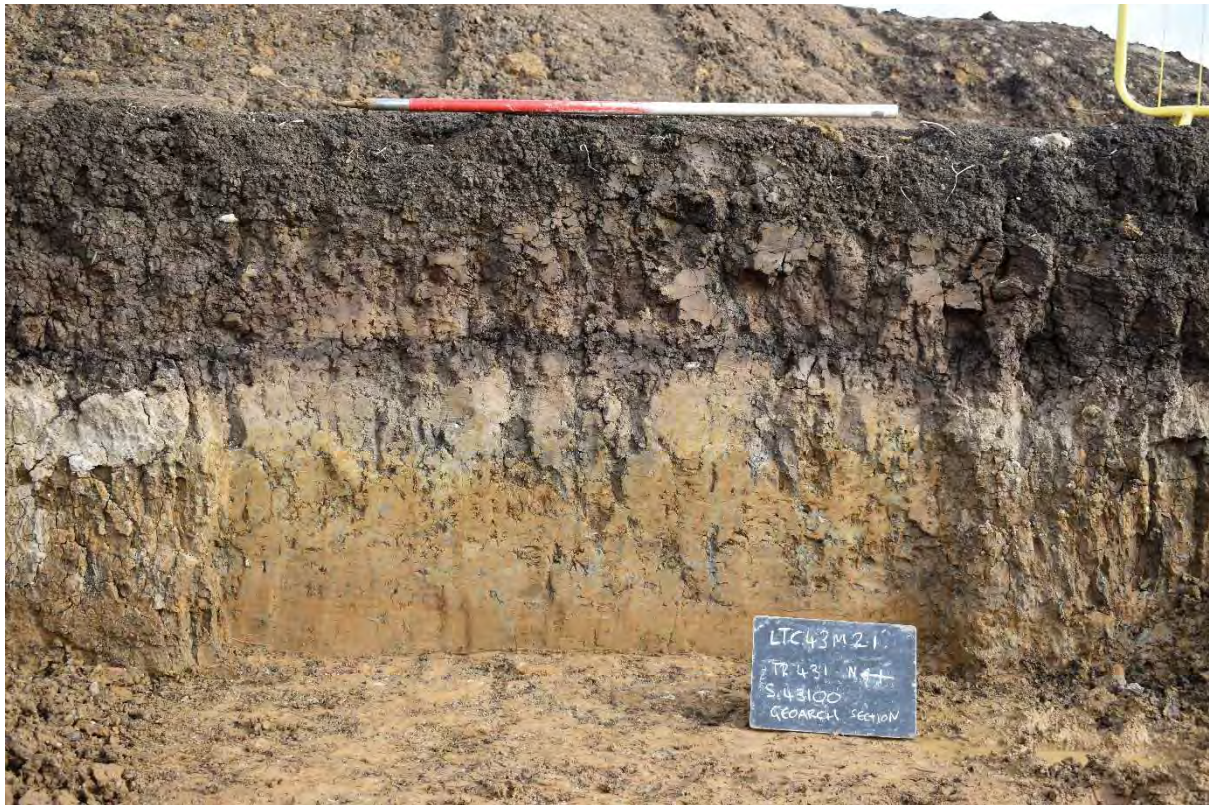

Plate 70: Transect 8, Trench 431, Section 43100 – Intercalated alluvium and stabilisation horizons overlying leached horizon on Mar Dyke floodplain. Section location is within faint palaeochannel identified on LiDAR imagery



Plate 71: Transects 9 and 11, Trench 433, Section 43300 – Mar Dyke alluvial deposits overlying potential channel deposits



Plate 72: Transects 9 and 11, Trench 434, Section 43400 - Mar Dyke alluvial deposits overlying potential channel deposits



Plate 73: Transect 9, Trench 406, Section 40600 – Sedimentary sequence occurring on floodplain margins, containing leached horizons



Plate 74: Transects 10 and 11, Trench 435, Section 43501 – Intercalated alluvium and stabilisation horizons overlying leached horizon on Mar Dyke floodplain



Plate 75: Transect 10, Trench 454, Section 45406 – Head and London Clay deposits on southern Mar Dyke valley promontory, truncated by ditch 45416



Plate 76: Transect 10, Trench 445, Section 44500 - Intercalated alluvium and stabilisation horizons overlying leached horizon on Mar Dyke floodplain on LP 45B. Lower alluvium contained EIA pottery



Plate 77: Transect 11, Trench 435, Section 43501 – Monoliths and OSL samples from the upper 1m of alluvium and ephemeral stabilisation horizons overlying leached horizon on Mar Dyke floodplain on LP 45B. Lower alluvium contained EIA pottery

COVER SHEET

Title:	Archaeological Evaluation Report for Trial Trenching of Land Parcels 47 and 48f-h, Mar Dyke Valley between South Ockendon and Orsett, Essex
Project Name:	Lower Thames Crossing Enabling Works
Ref No:	HE540039-BAL-GEN-GEN-REP-HER-00063
Revision No:	P01
Review Date:	14/03/2022
Status:	S2 – For Information
No. of Pages	250

Rev	Date of Issue	Revision Status	Originator	Checker	Approver
P01	14/03/2022	S2	Conal Mundy	Jack Fletcher	Emily Erswell



Lower Thames Crossing

Archaeological Evaluation Report for Trial Trenching of
Land Parcels 47 and 48f-h, Mar Dyke Valley between South
Ockendon and Orsett, Essex

Document Number: HE540039-BAL-GEN-GEN-REP-HER-00063

March 2022



Revision	Production Date	Prepared by	Checked by	Approved for release by	Sections revised
1.1	March 2022	Mark Dodd Project Officer Tim Allen Senior Project Manager Oxford Archaeology	Steve Lawrence Senior Project Manager Oxford Archaeology		

This Evaluation Report has been prepared for Highways England in accordance with the terms and conditions of appointment stated in the Lower Thames Crossing (LTC) Technical Partner Contract. LTC cannot accept any responsibility for any use of or reliance on the contents of this document by any third party.

Contents

Section	Page
Summary	8
Acknowledgements	10
1 Introduction	11
1.1 Project details and scope of work	11
1.2 Location, topography and geology	12
1.3 Archaeological and historical background.....	12
2 Project Aims	21
2.1 General aims	21
2.2 Specific objectives	22
3 Methodology	24
3.1 Constraints.....	24
3.2 Methodology for the evaluation.....	24
4 Results	25
4.1 Introduction and presentation of results	25
4.2 General soils and ground conditions.....	25
4.3 General distribution of archaeological deposits	25
4.4 Trenches 6, 13 and 14 (Figs 5 and 11).....	26
4.5 Trenches 69, 86, 90 and 94 (Figs 6 and 10)	27
4.6 Trenches 20, 22, 24, 25, 26, 30, 37, 44 and 46 (Figs 3 and 4)	29
4.7 Trenches 44, 55 and 61 (Fig. 4).....	31
4.8 Trenches 60, 72 and 96 (Fig. 7).....	31
4.9 Trenches 19, 81 and 106 (Figs 8-10 and 12).....	32
4.10 Trenches 107, 109 and 110 (Fig. 4).....	32
4.11 Finds summary	33
4.12 Environmental summary	33
5 Discussion	35
5.1 Reliability of field investigation	35
5.2 Interpretation.....	35
5.3 Evaluation objectives and results.....	40
Appendix A Trench Tables	45
Appendix B Finds Reports	107
Appendix C Environmental Reports	128
Appendix D References	206
Appendix E Abbreviations and Glossary	213
Appendix F Site Summary	214

Figures

Figure 1: Map showing the location of the Mar Dyke evaluation area

Figure 2: Trench and borehole layout of Land Parcels 47 and 48f-h

Figure 3: Overview of trenches and archaeological features in the northern area

Figure 4: Overview of trenches and archaeological features in southern area

Figure 5: Detailed plan of Trenches 6, 13 and 14

Figure 6: Detailed plan of Trenches 69, 86 and 90

Figure 7: Detailed plan of Trenches 60, 71 and 72

Figure 8: Detailed plan of Trench 19

Figure 9: Detailed plan of Trench 81

Figure 10: Detailed plan of Trench 106

Figure 11: Sections 1302, 1400 and 6900

Figure 12: Sections 8602, 1902, 8100 and 10600

Figure 13: Detail of wooden stakes 1410 and 1422 from the structure in Trench 14

Figure 14: Geoarchaeological Transect 2, Boreholes OCA-WS201 to 203A and Trenches 1, 8, 16, 18, 32, 48, 74 and 75

Figure 15: Geoarchaeological Transect 3, Boreholes OCA-WS301 to 323A and Trenches 1, 10, 11, 17 and 20

Figure 16: Geoarchaeological Transect 4, Boreholes OCA-WS402 to 416 and Trenches 86, 94 and 107-9

Figure 17: Geoarchaeological Transect 5, Boreholes OCA-WS501 to 505 and Trenches 6 and 14

Figure 18: Geoarchaeological Transect 12, Boreholes OCA-WS39 and 310A and Trenches 1-4, 6 and 7

Figure 19: Geoarchaeological Transect 13, Trenches 32, 27-9, 35, 44-5 and 37-8

Figure 20: Geoarchaeological Transect 14, Borehole OCA-WS402 and Trenches 73, 75-77, 80, 79, 91, 93, 90, 86, 95-96 and 72

Figure 21: Location of palaeo-environmental subsamples and radiocarbon dates processed from key sediment profiles

Plates

Plate 1: Cremation pit 605, looking south

Plate 2: Pit 1311, looking north-west

Plate 3: General view of Trench 14 with flags marking the locations of postholes 1403, 1405 and 1407, looking SSE

Plate 4: Timbers 1410 and 1422, looking east

Plate 5: Timber 1422, looking east

Plate 6: NNW facing section of Test Pit AAA (S.8602), Trench 86

Plate 7: Flint scatter 8603 in Test Pit AAA following excavation of Spit 2, looking WSW

Plate 8: Cremation pit 9007, looking north-west

Plate 9: Ditch 8104 looking south-east

Plate 10: Possible pit 10603, looking south

Plate 11: Weathered bedrock overlain by brickearth and a thin alluvium, Borehole OCA-WS201A, 0-3m, Transect 2 (ground surface, top left)

Plate 12: Alluvial and peat sequence, Section 1601, Trench 16, Transect 2

Plate 13: Weathered bedrock overlain by gravelly Head, sealed by brickearth and intercalated Holocene alluvial and peat deposits, Borehole OCA-WS304, 0-5m, Transect 3 (ground surface, top left)

Plate 14: Peaty deposit at 2.29-2.44m BGL within brickearth, radiocarbon dated to the late Glacial or early Holocene, Borehole OCA-WS307, 0-4m, Transect 3 (ground surface, top left)

Plate 15: Organic, gleyed and gravelly detrital palaeochannel deposits (later prehistoric) overlying weathered bedrock, OCA-WS316, 0-5m, Transect 3 (ground surface, top left)

Plate 16: Basal low-level fluvial gravel beneath brickearth exposed at c 2m BGL in Section 9701, Trench 97

Plate 17: Organic and gleyed palaeochannel deposits (later prehistoric) overlying weathered bedrock, OCA-WS414A, 0-5m, Transect 4 (ground surface, top left)

Plate 18: Organic and gleyed palaeochannel deposits (later prehistoric) overlying weathered bedrock, OCA-WS405A, 0-5m, Transect 4 (ground surface, top left)

Plate 19: Organic and gleyed palaeochannel deposits (later prehistoric) overlying weathered bedrock, Section 10700, Trench 107

- Plate 20: Eroded and disturbed peat deposits within the main palaeochannel, Section 10704, Trench 107
- Plate 21: Eroded peat clasts and fine sandy laminations within the main palaeochannel, Section 9701, Trench 97
- Plate 22: Organic and gleyed palaeochannel deposits (later prehistoric) overlying weathered bedrock, OCA-WS503A, 0-5m, Transect 5 (ground surface, top left)
- Plate 23: The sediment sequence associated with stake 1410 of the timber structure in Section 1400, Trench 14, Transect 5. Stake 1422 adjacent was radiocarbon dated to the early Iron Age at 760-410 cal BC
- Plate 24: Organic and gleyed palaeochannel deposits (later prehistoric) Section 3801, Trench 38, Transect 13
- Plate 25: Higher level gravel deposits in Section 7601, Trench 76, Transect 14
- Plate 26: Basal sand and gravel overlain by brickearth and capped by alluvium, Section 9100, Trench 91, Transect 14. Note the leached horizon at the top of the brickearth

Tables

- Table 1: Pottery from context 8603
- Table 2: Summary of remaining pottery assemblage by context
- Table 3: Basic quantification of the flint assemblage
- Table 4: Worked flint from Test Pit AAA, scatter 8603
- Table 5: Microliths from Test Pit AAA, scatter 8603
- Table 6: Basic quantification of flint from trenches other than Trench 86, by context type
- Table 7: Summary catalogue of flint by context
- Table 8: Summary of fired clay assemblage
- Table 9: Assessment of bulk samples
- Table 10: Summary of waterlogged samples
- Table 11: The waterlogged flots
- Table 12: The waterlogged plant assemblages from borehole samples
- Table 13: Summary of the cremation deposits
- Table 14: Summary of osteological findings: Cremation deposits

- Table 15: Bone weight calculations for the unsorted 2-4mm fractions
- Table 16: Summary of the unsorted <2mm fractions
- Table 17: Radiocarbon determinations
- Table 18: Results of paired χ^2 test on sediment from monolith 58 (1412) at 0.08-0.09m (end points of the combined calibrated date are rounded out by 10 years)
- Table 19: Results of paired χ^2 tests on sediment sample from monolith 59 (1414) at 0.12-0.13m (end points of the combined calibrated date are rounded out by 10 years)
- Table 20: Results of paired χ^2 tests on sediment sample from monolith <10> (10706) at 0.32-0.33m (end points of the combined calibrated date are rounded out by 10 years)
- Table 21: Results of paired χ^2 tests on peat samples from WS414A at 2.63-2.64m (end points of the combined calibrated date are rounded out by 10 years)
- Table 22: Results of paired χ^2 tests on humic sediment from OCA-WS-307 at 2.38-2.39m (end points of the combined calibrated date are rounded out by 10 years)
- Table 23: Results of paired χ^2 tests on organic sediment from <10> (10702) 0.11-0.12m (end points of the combined calibrated date are rounded out by 10 years)
- Table 24: Details of the ostracod samples
- Table 25: Presence/absence of environmental remains by depth with ecological synopsis
- Table 26: Summary of samples for diatom assessment
- Table 27: Summary of diatoms encountered within assessed samples
- Table 28: Details of pollen subsampling
- Table 29: Pollen grain counts per sample by species
- Table 30: Summary of borehole locations
- Table 31: Summary of selected geoarchaeological section locations
- Table 32: Summary of trench samples recovered from sediment sequences
- Table 33: Summary of subsample numbers from monoliths and cores, and bulk samples (WPR) from key sediment sequences

Summary

Oxford Cotswold Archaeology was commissioned by Balfour Beatty to undertake a trial trench evaluation of land parcels 47 and 48f-h covered by WSI P of the Lower Thames Crossing Pre-Enabling Works. These land parcels are located in the Mar Dyke valley between South Ockendon and Orsett within the county of Essex and Thurrock unitary authority (NGR TQ 62012 83241). A total of 123 trenches were dug and recorded between 13th August and 5th November 2021.

The investigations revealed a series of palaeochannels meandering on an E-W alignment across the northern section of the investigation area, then looping around the eastern edge and returning along the southern edge of the site. These palaeochannels contained alluvial sequences in excess of 3m deep providing good conditions for the preservation of waterlogged plant and insect remains and pollen. The centre of the site, around which the palaeochannels had formed was a slightly raised promontory of head deposits, at a height of 4-4.5m aOD. To the west of this elevated area the topography sloped down to a height of approximately 3.1m aOD but no palaeochannels and only a thin layer of alluvium were seen on this side of the site.

On the southern edge of the raised promontory a dense scatter of 1254 worked flints, with diagnostic material of late Mesolithic date, was found, concentrated in Trench 86 and extending south into Trench 90. The assemblage included microburins, microliths and a tranchet axe/adze sharpening flake. A small quantity of early Neolithic pottery, representing at least six different vessels were also recovered from the top of the flint scatter in Trench 86, and some of the upper flints may also be of this date.

The remains of other flint scatters were recorded on the north and east edges of the promontory and floodplain in Trenches 20 and 72 respectively, and smaller groups of flint in most of the trenches along the north edge. Whilst these included a high proportion of blades suggesting later Mesolithic or early Neolithic technologies, some were also mixed with later prehistoric material.

Assessment of the borehole and trench transects identified two palaeochannel cuts on both the north and south sides of the promontory. The channel crossing Trench 14 on the north was radiocarbon-dated to the middle Bronze Age, while those on the south were dated to the early and middle Bronze Age. The character of the sediments filling both sets of channels and the wider floodplain thereafter, and the environmental evidence from the organic sediments and peats, was similar, and indicated a gradual silting of the channel system, becoming slow-flowing by the early Iron Age. Environmental evidence demonstrate increased clearance through to the middle Iron Age, with grazing throughout and possibly some arable agriculture in the late Bronze Age and Iron Age. No evidence of marine transgression this far up the Mar Dyke river was found.

Few archaeological cut features were encountered. Two unurned cremations were found, in Trenches 6 and 90, and although without accompanying artefacts, charcoal from the cremation in Trench 6 was radiocarbon dated to the late Bronze Age. A scatter of pits, some containing charcoal, was also found, but no dating evidence. Later prehistoric sherds of pottery were recovered in small quantities from alluvial deposits or the surface of the natural in Trenches 22, 60, 69, 90 and 97 and part of a late Bronze Age, fired clay perforated plate from Trench 44.

In Trench 14 in the north-east part of the site a row of six waterlogged timber piles was found set within alluvial silt and traversing an east-west aligned palaeochannel. One of the timbers has been radiocarbon dated to the early Iron Age. The full extent of the structure is unknown at this stage but may have formed a footbridge across the channel.

Roman, Saxon/early medieval and medieval evidence is absent, although a widespread deposit of peat overlying the channels and thought to represent a phase of the Mar Dyke fen was dated to the mid-late Saxon period. No early post-medieval activity nor any drainage ditches were evident either, and historic maps provide the first evidence for partial drainage of the fen after the canalisation of the Mar Dyke, probably in the 18th century, but as the maps make clear, the majority of the site remains fen throughout the 19th century.

Acknowledgements

Oxford Cotswold Archaeology would like to thank the client, Balfour Beatty, for commissioning this project and managing the site safety and attendances. Thanks are also extended to the Historic Environment Consultant, Richard Havis of Place Services at Essex County Council, who advises the Borough of Thurrock, for monitoring and providing advice throughout the project.

The project was managed for Oxford Cotswold Archaeology by Steve Lawrence and the fieldwork was directed by Mark Dodd. The site was supervised by Jack Easen and Christof Heistermann, and they were supported by Agata Kowalska, Alessandra Rossi, Alex Capon, Anna Lound, Ashley Joynes, Benjamin Massey, Benjamin Slader, Bevan Cope, Charlotte Brown, Chris Griffiths, Christopher Smallwood, Ciar Boyle Gifford, Dan Firth, Eilidh Barr, Gemma Deaney, Georgina Matthews, Graeme Botham, Greg Owen, Harlie Mason, Heather Beckett, Holly Owen, Holly Wright, Jessica Domiczew, Joan Roig, Joseph Smith, Kamil Prus, Kat Whitehouse, Kerree Foster, Lily Andrews, Mar Roig Oliver, Marionna Sandin Catacora, Mia Long, Molly Vowles, Nat Pacholek, Rose Britton, Stephen Foster, Tanja Peter, Tara Schug, Tiger-Lily Mileto, Tom Bruce, Tom Hayes and Tomasso Rossi. Site survey was undertaken by Caroline Souday, James MacCallum and Elodie Powell and digitising was carried out by Caroline Souday and Lucy Gane. Thanks are also extended to the teams of OA staff that cleaned and packaged the finds and processed the environmental remains under the management of Natash Dodwell, and prepared the archive under the management of Nicola Scott.

1 Introduction

1.1 Project details and scope of work

- 1.1.1 The Lower Thames Crossing Project is located between the A2 in Kent and the M25 in the London Borough of Havering. It will run underneath the River Thames through a tunnel and emerge on the northern side of the river at East Tilbury. From the North Portal the road will run to the M25 at Junction 29 via the A13 and pass between North and South Ockendon. The development of the project is managed by LTC, a partnership between Highways England and a consultancy joint venture set up to oversee the scheme.
- 1.1.2 A programme of archaeological trial trenching commenced in the Essex part of the scheme in November 2019. A scheme-wide specification for trial trenching was written by LTC (Highways England 2018), and in July 2019, LTC commissioned Balfour Beatty to deliver the pre-Enabling Works. Balfour Beatty appointed Oxford Archaeology (OA) to prepare a project-wide written scheme of investigation (WSI) for the scheme, which (at the request of the key archaeological stakeholders) is divided into two parts, one for the Kent section, and another for Essex and Havering (Oxford Archaeology 2020a; 2020b).
- 1.1.3 Following completion of the project-wide WSIs, OA was instructed to prepare a series of site-specific or group-site specific WSIs for approval by the key archaeological stakeholders in advance of trial trenching to inform the Development Consent Order (DCO). A detailed WSI was created for Land Parcels 43, 45-48 and 120-125 prior to the trial trenching (WSI P, Oxford Archaeology 2021), which details the archaeological background and potential within the site. It also sets out the archaeological aims and objectives appropriate to the investigation of this land parcel by trenching and describes the methodology to be applied. The WSI was approved by Richard Havis, Principal Historic Environment Consultant for Place Services at Essex County Council, prior to the start of the fieldwork. Oxford Cotswold Archaeology was commissioned as Balfour Beatty's archaeological contractor to undertake the evaluation in accordance with the approved WSI and local and national planning policies.
- 1.1.4 Although Land Parcels 120-122 were excluded from the evaluation, the swathe across the Mar Dyke valley that was evaluated for the scheme covered a very large area that involved the excavation of nearly 550 trenches. For this reason, the area evaluated was divided into three for reporting purposes: Mar Dyke south covering Land Parcels 48b and c, Mar Dyke north covering Land Parcels 43, 45a-e and 46, and Mar Dyke centre covering Land Parcels 47 and 48f-h. The southern and northern parts have already been reported upon, and this document summarises the results of the trial trenching undertaken in Land Parcels 47 and 48f-h.
- 1.1.5 The fieldwork in Land Parcel 47 and 48f-h was completed between 13th August and 5th November 2021. All work followed the MoRPHE Project Manager's guide (Historic England 2015a), and the Code of Conduct of the Chartered Institute for Archaeologists (CIfA). The archaeological works

adhered to the standards and guidance for archaeological evaluation, excavation and archiving (ClfA 2014a; CIFA 2014b).

- 1.1.6 The work was monitored by Richard Havis of Place Services on behalf of the Borough of Thurrock.

1.2 Location, topography and geology

- 1.2.1 Land Parcels 43, 45-48 and 120-122 within the boundary of the scheme cross the Mar Dyke valley from north-west to south. Parcels 121 and 122, which were not included in the evaluation, lie within the historic parish of North Ockendon in the London Borough of Havering. Parcels 43, 45-48 and 120 (the last also excluded from the evaluation) are located in the historic parish of South Ockendon in Thurrock unitary authority within the county of Essex (Fig. 1) (NGR TQ 62012 83241). The town of South Ockendon is located 0.4km south-west of the site and the village of Orsett is located 1km south-east of the site. To the west, north and east the site is bounded by agricultural fields and to the south the site is bounded by Green Lane which continues eastwards to Orsett.
- 1.2.2 The bedrock geology of this site is London Clay Formation (clay, silt and sand). The superficial geology of the land parcel is mixed, the majority of the site is situated in an area of alluvial deposits formed by the Mar Dyke river. There are also deposits of Head Clay located on the slopes of the valley within the north-western and southern parts of the site, and on the two small areas projecting east in the central part of the site. The colluvial layer of Head was formed by fine-grained materials collecting on slopes and at the base of a slope (BGS 2019). Within the western part of the site there is an area where there are no recorded superficial deposits due to modern quarrying.
- 1.2.3 The majority of the site is currently in use as arable fields located east and west of the Mar Dyke river. Land Parcel 121 at the northern end of the site is part of the Top Meadow Golf Course and a pond is located at the eastern end of this land parcel. The majority of Land Parcel 46 is a quarry, with areas of backfilled rough ground, but the south-western corner is a scheduled medieval moated site (**1002155**). Within the 1km study area the land use is mostly agricultural with urban development associated with the town of South Ockendon located 0.4km south-west of the site.
- 1.2.4 A central swathe of the site is located within the Mar Dyke river valley floodplain (the eastern part of Land Parcel 45, Land Parcel 120, the western part of Land Parcel 47 and the northern part of Land Parcel 48). This area of the site is located at 0-2m aOD. The southern part of Land Parcel 48 is on the valley slope, and rises up to 16m aOD at the southern edge. The eastern part of the site (Land Parcel 47) is located on the edge of a low promontory which rises up to c 10m aOD at the eastern edge. The north-western part of the site is located on the slopes of the western side of the Mar Dyke valley and rises up to c 29m aOD at the western edge of the site.

1.3 Archaeological and historical background

- 1.3.1 The chronological summary of known archaeology given below is taken from WSI P for the Mar Dyke valley (Oxford Archaeology 2021).

- 1.3.2 Land Parcels 47 and 48f-h, are situated mostly in the floodplain of the Mar Dyke valley, with the exception of a promontory of higher and drier ground that extends eastwards from the west side of the valley into Land Parcel 48h. No cropmarks have been identified within this area, and finds have been very few, as part of this area was the Mar Dyke fen, and this was unsuitable for development or for agriculture. Cropmarks have been recorded around these land parcels, and these are those mapped by the Aerial Investigation and Mapping report (Place Services 2019).
- 1.3.3 In order to provide context for the discoveries, the archaeological background that follows deals with the whole of that part of the Mar Dyke valley crossed by the scheme, rather than simply that part covered by the land parcels reported upon in detail here.
- 1.3.4 **Palaeolithic.** No known finds of Palaeolithic date are known from the site. A Palaeolithic handaxe was found on the surface of the ground along the south-western boundary of land parcel 46 at South Ockendon Hall. The find was discovered in 1978 when a windmill on the south side of the moat was demolished. This object may have been disturbed during the excavation of the nearby moat.
- 1.3.5 **Mesolithic.** No known Mesolithic flints have been recorded within the site. During an excavation at the William Edwards School 1km south of the site residual flints of Mesolithic and Neolithic date were recorded.
- 1.3.6 **Neolithic and early Bronze Age.** No certain Neolithic or early Bronze Age features or finds have been recorded within the site or the 1km study area.
- 1.3.7 A cropmark possibly representing a large sub-circular enclosure 45m across and with opposing entrances is located 0.3km west of the site, and if archaeological, this might well represent a late Neolithic henge monument. A smaller cropmark penannular enclosure was also recorded 150m west of the site, and this could conceivably also be of earlier prehistoric date. During the Horndon to Barking Gas Pipeline Watching brief (Site 7) a shallow pit, 0.37m in diameter and 0.16m deep was recorded just north of enclosure, which contained cremated bones of a mature/older adult female. There were no finds, but this could date from the later Neolithic or Bronze Age.
- 1.3.8 The cropmarks of two parallel lines with a rounded terminal were identified 0.8km south-west of the site. This feature may have been a long-barrow or long mortuary enclosure of early or middle Neolithic date.
- 1.3.9 A ring ditch was recorded 0.3km south of the site on the slopes of the Mar Dyke valley. This feature is 32m diameter and may represent the site of a ploughed out Bronze Age barrow.
- 1.3.10 A flint arrowhead was found 250m east of the site in the 19th century. The arrowhead was only dated as prehistoric but was probably of early Bronze Age date.
- 1.3.11 **Later Bronze Age and Iron Age.** Within the western part of the site a ditch containing late Bronze Age finds was found during the Horndon to Barking gas pipeline. This ditch was on a SW-NE alignment and was parallel to, and 40m north of, the existing field boundary. The ditch contained a relatively large quantity of burnt flint and three sherds of flint-gritted pottery, probably of late Bronze Age date. A second ditch on a parallel alignment produced a single

sherd of late Bronze Age pottery along with 19th-20th century pottery. These ditches, which follow the downward slope of the topography, may conceivably indicate survival of ancient field systems, or may have cut through late Bronze Age features on the slopes of the Mar Dyke Valley.

- 1.3.12 Two rectilinear cropmark enclosures, one only partially visible, and a system of linear boundaries probably representing a field system have been identified in the northern part of the site. Although currently undated, these may be of later prehistoric date, or alternatively may be Roman (see below).
- 1.3.13 The cropmark of a long curving ditch following an irregular course was recorded as part of the aerial mapping survey within the eastern part of the site. This defines the western edge of a promontory and follows the topography of an area of higher ground. This feature can also be seen as an earthwork on LiDAR imagery, and it is therefore possible that there is a bank and a ditch at this location. Late Iron Age pottery was found nearby on the edge of this promontory during the Horndon to Barking gas pipeline located 100m north-east of the site. It is possible that the bank and ditch are of later prehistoric date and the siting of it may suggest a defensive site. Alternatively, these features may represent a medieval or post-medieval field boundary, although it differs in character to the regular north-south post-medieval field boundaries just to the east.
- 1.3.14 Some 1.5-2km north of the scheme at Bulphan Fen a series of small cropmark enclosures have recently been evaluated, and have proved to represent a settlement of late Bronze Age to early Iron Age date (Cotswold Archaeology 2022). The site also produced late Iron to early Roman features including a trackway, enclosure ditches shallow linear gullies, pits and postholes.
- 1.3.15 On the southern edge of the Mar Dyke valley the scheduled Orsett cropmark complex is located on the gravel terrace 0.4km south of the site. The main concentration of enclosures, ring ditches (probable prehistoric round house gullies), trackways and field systems are located in the northern part of the monument. Recent evaluation of these and the land immediately to the north has confirmed that the complex is a mixture of late Bronze Age, early, middle and late Iron Age and Roman features (OCA 2020a and 2020b). A small probable ring ditch on the west edge of Land Parcel 22 some 600m south of the site produced struck flints of later Bronze Age character, and much of a late Bronze Age vessel was recovered from a pit elsewhere within the complex.
- 1.3.16 In 1979 the southern part of the Orsett (Grey Goose Farm) Cropmark Complex was excavated during alterations to the A13, and several late Bronze Age to early Iron Age features, comprising one large and three small pits, postholes and a gully. These features were mostly located in the A1089 loop junction just north of the A13 (Wilkinson 1988, 13-16). The A13 investigations also found that some of the 'pits' were of geological origin (Wilkinson 1988), and the recent evaluations have confirmed that most of the discrete cropmarks are geological, although one pit alignment that continues as a ditch appears to be archaeological (OCA 2020b).
- 1.3.17 Two possible prehistoric cropmark enclosures have been identified east of the Orsett scheduled complex, and the site of a scheduled probable late Bronze Age enclosure lies some 950m south-east of the site. To the west of the Orsett

Cropmark complex and 0.8km south-west of the site, an excavation at William Edwards school revealed late Bronze Age and early Iron Age settlement (Lavender 1998).

- 1.3.18 Bronze Age and Iron Age pottery were recovered from a mound 200m south of land parcel 46 of the site. This mound may have been one of three Roman barrows once present around South Ockendon Old Hall. Two sherds of Iron Age pottery were also found during the excavation of the Roman scheduled barrow located immediately west of the site. The Roman barrows may have truncated Bronze Age or Iron Age features during their construction.
- 1.3.19 In 1966, 13 Bronze Age weights were found in a clay pit 0.6km west of the site. The exact purpose of these weights is unknown but they may have been roof weights or loom weights. These finds were recorded in the vicinity of the cropmarks of a circular feature. The feature was recorded by the HER as a ploughed out mound but it is possible this may have been a domestic Bronze Age enclosure.
- 1.3.20 A number of cropmarks have been recorded on the area of higher ground to the west of the site. This includes a trackway and linear features north-west of South Ockendon Hall, a ring ditch and a number of pits 0.5km south of the site, ring ditches and a possible mound located 0.6km from the site and further ring ditches and rectilinear features 1km south of the site. It is likely that some of these features are later prehistoric or Roman in date.
- 1.3.21 The cropmark of a possible enclosure was recorded by the GLHER 0.7km north-west of the site. This enclosure is located on the higher gravel terrace above the Mar Dyke valley and may date from the later prehistoric period.
- 1.3.22 **Roman period.** A scheduled burial mound lies adjacent to, and just west of, the site on the high ground of the terrace edge on the western side of the Mar Dyke river valley. In 1957 a trench through this barrow found 17 sherds of Roman pottery, although the central burial was not disturbed. This barrow may have been one of three spaced a similar distance apart. A second barrow was located c 400m south of the scheduled barrow, and was excavated prior to removal, the finds being dated to the late second century AD. A third barrow is also documented, though it was the first to be destroyed and its exact location is now unknown. An east-west trackway and other linear features that may be Roman in date were identified north of South Ockendon Hall by the aerial mapping survey.
- 1.3.23 A possible Roman cemetery was excavated in the vicinity of the northern part of the site in the 19th century but the exact location of this discovery is unknown. The Essex HER places this just east of the site whilst PastScape places this event within the northern part of the site. The details of both entries are the same, namely that in 1858 farm laborers found Roman pottery, animal bones and charcoal within shallow pits of black earth 3-12m diameter wide in a field within the Mar Dyke valley. This site extended for 2.4 hectares. A number of these pits contained parts of vessels, and were located equidistant from one another. The absence of human bones may simply be due to effective cremation of the remains, but the large size of the features described makes it unlikely that these represent cremation burials, though they might indicate pyre sites. On balance, the 'urn sherds' reported may simply represent domestic pottery.

- 1.3.24 One of the fields in which the remains were found in was called 'Ruin Field' and so it is possible that these features may have been part of a settlement that contained one or more buildings. The tithe maps for North Ockendon, South Ockendon, Bulphan and Orsett were checked for references to 'Ruin Field' but none was found.
- 1.3.25 Two rectilinear enclosures have been identified as cropmarks within the northern part of the site. The more northerly had an uncertain relationship with part of a field system to the south, but was possibly cut by it. The two parallel ditches running WSW-ESE run between two existing field boundaries, so may be post-medieval field boundaries. These enclosures are located on slightly higher ground just above the floodplain. Given their morphology, and their proximity to the possible Roman settlement and/or cemetery, these enclosures may be of Roman (or later prehistoric) date.
- 1.3.26 The Orsett cropmark complex, located 0.4km south of the site, may include evidence for Roman activity as Roman activity has been recorded nearby. A cropmark site to the west at Stifford Clays-Primrose Island and 0.9km south-west of the site was excavated in the 1960s and 1970s, and revealed a farmstead that was in use from the late Iron Age to the late Roman period with enclosures, ditches, pits, cremations and a corn drying oven. Another Roman enclosure site was identified close to the Orsett cropmark complex, on the edge of the terrace, and 0.8km south-east of the site. Roman finds have also been recorded on the terrace. These sites are strung along the north edge of the gravel terrace, and may well have been linked by tracks or a road to Roman settlements around Orsett Cock further east, close to a Roman road.
- 1.3.27 Roman finds have been recorded in the western part of the study area. This includes a coin of Marcus Aurelius (AD 161-180). Sherds of Roman pottery of mid-1st to mid-2nd century AD date were found whilst stripping the topsoil during an excavation at South Ockendon Hospital.
- 1.3.28 During construction of the Epping-Horndon Gas Pipeline Roman pottery was found 0.9km north-east of the site.
- 1.3.29 **Medieval period.** No Saxon features or finds have been recorded within the site, and only limited evidence of Saxon activity has been found within the study area.
- 1.3.30 A dense pattern of pits of varying size and shape are dispersed across the Orsett Cropmark Complex located 0.4km south of the site. The pits that appear elongated in shape are thought likely to represent Saxon grubenhouse (sunken-featured buildings) (Place Services 2019). However, excavations directly to the south of the monument and 0.9km south of the site indicated that features identified as pits by cropmark interpretation were primarily of natural origin. Saxon artefacts were however recorded in some features. A late Saxon baked clay loomweight was recovered from one of the features.
- 1.3.31 Documentary evidence suggests that this area was occupied during the Saxon period. During the late Saxon period the area of the site was very likely part of the manorial estate of North and South Ockendon and also the manor of Orsett. The Domesday survey notes that North and South Ockendon was very large or the period with 90 households. Orsett was also large with 61 householders. These three settlements included entries for plough teams,

pigs and sheep indicating a mixed agrarian economy (Palmer 2019). The division between these manors may have later formed the later medieval parish boundaries. The division boundary between the parishes of South Ockendon and Orsett is the Mar Dyke river. The division between South Ockendon and North Ockendon is more arbitrary and runs along field boundaries to the south of Fen Lane and drainage ditches to the north-east of the site.

- 1.3.32 The roads within this part of the scheme appear to have a roughly NNW-SSE and east-west alignment and this could relate to the formation of the parishes or the use of more ancient droveways. The medieval road network is probably much the same as is shown on the OS First edition of 1805 (not illustrated), as the area remained undeveloped into the 20th century. This map shows the north-south road (North Lane) from Puddle Dock to North and South Ockendon (now the B186) which is just west of the site. Fen Lane aligned east-west, bisects the northern part of the site and linked North Ockendon to the village of Bulphan.
- 1.3.33 **South Ockendon.** The church of St Nicholas in South Ockendon is located 800m west of the site and dates from the 12th century. The nucleated settlement of South Ockendon was likely to have been located around this church and farmsteads scattered throughout the parish.
- 1.3.34 A medieval moated manor was located at South Ockendon Hall located within the south-western part of the site, which is now scheduled. The manor here was known as 'Bruyns' and was certainly established by the 12th century but may have late Saxon origins. This manor house may have been rebuilt several times during the post-medieval period. The moated site does not have any remaining structures internally except part of a medieval gatehouse. It is likely that medieval and post-medieval remains may be located below ground. This manor was split in the early 16th century and the manor of Groves was created to the north. It is possible that there were water management ditches associated with the moat which may extend into the area of the site. A possible watermill which was later replaced by a windmill was located on the south side of the moat. This is thought to be post-medieval in date, but it is possible the watermill may have been medieval in date and contemporary with the medieval moat. This would have required an extensive water management system of drainage ditches, leats and sluice gates which may have extend into the area of the site. It seems plausible that the moat and possible watermill were fed by a spring line on the terrace since the Mar Dyke river is located downslope to the east.
- 1.3.35 is possible that there was a medieval settlement located around the area of the moated manor which may extend eastwards into the area of the site. Cropmarks have been identified 400m north-west of the moated manor house and these extend into the western edge of the site. These include rectangular enclosures, linear features and pits. In addition, an east-west trackway was identified by the aerial survey to the north-west of the hall along with a rectangular enclosure. It is possible this track could be medieval or earlier in date. Further linear features have been recorded as cropmarks 0.5km west of the site. It is possible the enclosures and linear features could define stock

enclosures and field systems associated with the manor. Alternatively, these features may be of postmedieval date and associated with the later manor house.

- 1.3.36 In 1995 the western part of the site was subjected to a geophysical survey and a number of irregularly spaced linear features were recorded. These were interpreted as ridge and furrow of medieval date but may also be post-medieval in date. It is likely that this ridge and furrow is associated with the medieval or post-medieval manor of South Ockendon Hall.
- 1.3.37 **Orsett.** The site is located on at the western extent of the manor and later parish of Orsett. The site of Bishop Bonners Palace is scheduled and located 900m south-east of the scheme on the north edge of Orsett. This ringwork and bailey earthwork belonged to the Bishops of London during the medieval period. The later medieval settlement of Orsett was situated south of Bishop Bonners Palace around the Church of St Giles and All Saints. The Church of St Giles and All Saints, located 1.4km south-east of the site has elements of architecture dating to the 12th century with extensive 14th and 15th century alterations. The later medieval settlement of Orsett was located c 1.1km south-east of the site. The hamlet of Baker Street, west of Orsett, and 800m south-east of the site may have been founded in the later medieval period.
- 1.3.38 The cropmarks of a possible medieval moated site were identified on the slopes of the valley and within the Land Parcel 48 of the site. Several other possible medieval moated sites have been identified as cropmarks just east of the site and within the parish of Orsett. This includes the cropmarks of two sub rectangular enclosures jointed by a wide ditch located 300m east of the site. This could indicate the site of a double medieval moated site. An additional ditch is located just north of the easterly ditch. Another possible moat was recorded nearby but the HER recorded this as destroyed so it may be on the site of a modern reservoir. Another medieval moat is recorded by the HER at Spinny Farm located 0.5km north-east of the site.
- 1.3.39 A number of possible medieval or post-medieval field boundaries were identified by the aerial mapping survey within the site and the parish of Orsett. This includes a number of NNW-SSE aligned linear features on a promontory within the eastern part of the site. It also includes a number of NNW-SSE and ENE-WSW aligned linear features on the terrace within the southern part of the site. These features are likely to be field boundaries of medieval or post-medieval date. Two medieval ditches were recorded just north of Land Parcel 47 of the site during the Horndon to Barking Gas Pipeline. One ditch was parallel to and approximately 3m from a low hedgerow and small metalled trackway. Hand excavation of one of the ditches produced two sherds of medieval pottery of 12th-13th century date.
- 1.3.40 **Post-medieval period.** During the post-medieval period the road network in the area of the site probably continued without significant change from that of the later medieval period. In relation to the principal estates of this period, the land parcels covered by WSI P were located within the North Ockendon Hall estate, the Grove Barns estate, The South Ockendon Hall estate and the Orsett Hall estate. Prior to the later 20th century this area retained a largely rural character with dispersed farmsteads along tracks.

- 1.3.41 The tithe map for North Ockendon (c 1841) (D/CT 260) indicates that the northernmost part of the site was in use as arable land owned by Richard Benyon of North Ockendon Hall.
- 1.3.42 The former later medieval or early post-medieval manor of Groves Barns is probably located adjacent and west of the site within an area of woodland. This manor may have been established c 1531 when the manor of Bruyns (South Ockendon Hall) was split, or there may have been an earlier building on this site. This manor house was recorded as having 22 hearths in 1670, which was the largest number of hearths for South Ockendon parish, and was therefore a substantial manor house. This manor house was extant until at least c 1772 but was demolished soon after. The only remains of this manor house above ground is a late 16th-early 17th century gateway and wall, now grade II listed and located c 100m north-east of the site.
- 1.3.43 The tithe map for South Ockendon (c 1840) (D/CT 261) indicates that Land Parcels 43, 120 and the southern part of Land Parcel 21 were in use as arable land within estate of John Henry Stewart of the manor of Groves.
- 1.3.44 An estate map of South Ockendon dated 1691 (D-DGe P5) indicates the extent of the manor of South Ockendon. The northern boundary of this manor was formed by field boundaries and one of these bisected the northern part of the site. This map also shows the postmedieval manor of Groves Barns on the northern part of the map, probably as a note of the shared heritage of the two manors. The tithe map for South Ockendon (c 1840) (D/CT 261) shows that Land Parcels 45 and 46 was in use as arable and pasture fields which belonging to the estate of John Cliff of South Ockendon Hall. The parish boundary on the east was the Mar Dyke river. Several post-medieval field boundaries were recorded by the HER just east of the Mar Dyke. These would have been located within the South Ockendon manor estate, but have subsequently been levelled.
- 1.3.45 The relatively straight course of the Mar Dyke river on the 1691 estate map appears to match the modern route of the river, suggesting that it might have been canalized, or at least straightened, prior to 1691. Records of flooding of the river in the 18th century as far up as Stifford, however, may indicate that the canalization was later than this. Chapman and Andre's map of Essex of 1777 certainly shows the Mar Dyke following the canalized course, so it probably took place in the third quarter of the 18th century. Mar Dyke Fen is marked on this map east of the canalized course, bounded on the south side by a series of farms: unnamed, Jotts, unnamed (containing only one building), Hoblets, unnamed and Larkins. The same outline is shown on the 1805 Ordnance Survey First Series map of 1805, but this map usefully shows the promontory of high ground bounding the fen on the north, which corresponds to that in Land Parcel 47. The fen therefore corresponds to the area south of this (Land Parcels 48F,48G and 48H).
- 1.3.46 A post-medieval mill was located on the south side of the medieval moated manor of South Ockendon Hall. This mill was a postmedieval wind powered smock mill which had been built on the site of a possible former watermill. The windmill was demolished in 1978. No trace of the watermill or windmill was found during a site visit in 2011. It is possible that the watermill or windmill

could have been medieval in date. As mentioned above, a series of medieval or post-medieval water management ditches may associated with this mill site.

- 1.3.47 The Orsett enclosure map of 1837 shows the extent of Mar Dyke Fen, which has not changed since 1805. The 1840 tithe map for Orsett D/CT 264/1 shows that the southern part of the site had number of owners including the Baker family and William Wingfield of Orsett Hall. There are several field boundaries which have been recorded by the aerial survey within the southern part of the site. These field boundaries appear on the 1840 Orsett tithe map and are therefore likely to be post-medieval in date, but some may be medieval in date.
- 1.3.48 The northern part of Land Parcel 48 is still labelled as Orsett Fen on the tithe map and this area is blank on the map and also on the later 19th century OS maps, showing that this area was still too wet to make use of for arable or pastoral purposes.
- 1.3.49 The tithe maps and later 19th century OS maps indicate that there were four post-medieval farms located within the site and two adjacent and outside the site. The four within the area of the site include Thrifts and Abrahams within Land Parcel 47, Botney Farm (on the site of a formerly unnamed farm) and Hobletts Farm just outside the southern edge of the fen in Land Parcels 48B and 48D, and Middle Farm in Land Parcel 121.
- 1.3.50 The two farms located just outside the site include Old Barn on the eastern edge of Land Parcel 46 and Chantry Farm just west of Land Parcel 48. At least three of these farms originated in the later medieval period including Thrifts and, Chantry Farm and Hobletts. All of these farms apart from Hobletts were demolished by the 1970s.
- 1.3.51 **Modern.** A number of 20th century military sites are located within the study area but none of these are located within the site itself. This includes a First World War landing site, a Second World War observation post which has now been destroyed, two heavy anti-aircraft gun sites and a Ground Controlled Interception Station.
- 1.3.52 In the late 20th century the majority of Land Parcel 46 and the south-west of the site was subjected to intensive quarrying. This removed all of the historic field boundaries in this area. The extent of the quarrying to the south-west of Land Parcel 46 is unknown and so there may be a small area where the superficial deposit have not been removed.
- 1.3.53 **Undated features and cropmarks.** There are a number of undated features which have been recorded within the site. This includes the two rectilinear enclosures and linear features within the northern part of the site.
- 1.3.54 The possible ditch and bank at the edge of the promontory within the eastern part of the site may be defensive in nature or may just be an unusually shaped field boundary above the floodplain. Although the field boundaries just east of this are aligned north-south and are likely far later in date.
- 1.3.55 A possible medieval moated site has been recorded as a cropmark within the southern part of the site. Other linear features within the southern part of the site may be medieval or post-medieval field boundaries.

2 Project Aims

2.1 General aims

2.1.1 The general aims of the project were as follows:

- i. To establish the presence or absence of archaeological remains along the line of the scheme, and the extent of any areas where remains appear likely to be absent.
- ii. In areas where archaeological remains are known or suspected, to clarify the reliability of the cropmark or geophysical survey evidence.
- iii. In areas where no archaeological remains are indicated by aerial or geophysical survey, to clarify whether this apparent absence of remains is genuine.
- iv. To determine the degree of complexity of any surviving horizontal or vertical stratigraphy, and in particular, to investigate areas where topography indicates the likelihood of deep deposit sequences for evidence of buried archaeological horizons and palaeo-environmental sequences.
- v. Where remains are present, to determine the period(s) represented, the extent, state of preservation and character of the archaeological remains.
- vi. To establish the range and state of preservation of archaeological artefacts, and through their recovery and examination, to establish the potential for information about the economy, status and contacts of past inhabitants of the scheme footprint.
- vii. To determine whether palaeo-environmental remains are preserved, and, where these are found, to determine their types (e.g. charred plant remains, waterlogged remains, molluscan remains), state of preservation and potential for environmental information. This will be achieved through the recovery of samples from sedimentary sequences and archaeological features suitable for assessment of a range of palaeo-environmental remains (e.g. charred and waterlogged plant remains, charcoal, insects, pollen, diatoms, ostracods/foraminifera and molluscs) and scientific dating (e.g. radiocarbon and OSL dating).
- viii. To investigate and record the extent, character and chronology of the sedimentary sequences, in particular those immediately adjacent to and in floodplains, contained within palaeochannels or in dry valleys, and to use the data to refine existing geoarchaeological (predictive) deposit models.
- ix. To place any identified archaeological remains into their local and, where appropriate, regional or national context, and to assess the implications of any such discoveries for our current understanding of settlement and landscape change in the area, including an assessment of the associations of any remains with reference to the historic landscape.
- x. To provide sufficient information to enable the LTC archaeological advisor, in consultation with the Key Archaeological Stakeholders, to determine the significance of the archaeological assets identified within the land parcel.

- xi. To provide a report on the discoveries to inform the Environmental Statement (ES) supporting the Development Consent Order (DCO) and support the preparation of a further archaeological mitigation strategy for the Enabling Works and Construction phases of the scheme.
- xii. Following the DCO, to deposit the report in the public domain, and to generate an accessible and useable archive which will allow future research to be undertaken.

2.2 Specific objectives

2.2.1 The specific project objectives were as follows:

- xiii. To conduct the programme of archaeological investigation within the general research parameters and objectives defined by the revised East of England Research Framework (ed Medlycott 2011).
- xiv. To establish the extent, depth and complexity of slope deposits, colluviation and alluviation, and to determine whether buried archaeological activity is preserved beneath or within them.
- xv. To clarify whether the wider Mar Dyke valley is of largely late Pleistocene date, or whether earlier Palaeolithic channel deposits and sediments associated with the Ockendon meander survive within it, using scientific dating to date key deposits.
- xvi. To establish the course(s) and complexity of the former late Glacial and Holocene channel system of the river, and to date its development.
- xvii. To clarify whether there are successive preserved sequences of channel deposits due to aggradation within the river valley as the river migrates across it, and if so, to examine evidence for activity on the edge of successive silted phases of channel, and across the wider alluvial floodplain.
- xviii. To identify areas along the edge of the former palaeochannels that may have been used for activity in the past, together with any islands or areas with only shallow seasonal inundation within the palaeochannels that may have had human activity, and if found, to characterise the type, date and complexity of activity upon and associated with them.
- xix. To look for evidence of archaeological artefacts and ecofacts within the river channels, whether structures or objects, and if found, to establish their state of preservation, date and character.
- xx. To clarify the tidal limit of the former Mar Dyke river by examining sediment sequences in the southernmost parts of the Mar Dyke palaeochannels within the scheme for evidence of saltwater.
- xxi. To aim to relate any activity found on the valley slopes to activity on the higher ground, and in particular to the cropmark evidence.
- xxii. To clarify whether the cropmarks provide an accurate representation of the range, quantity and types of archaeological features present on the areas without alluvial covering within the site.

- xxiii. To look for evidence of domestic activity of earlier prehistoric date that may be associated with the possible monuments suspected from cropmarks to the west and south of the site.
- xxiv. To establish the character and date of the two rectilinear enclosures and a nearby field system within the northern part of the site.
- xxv. To establish the character and date of the C-shaped ditch and bank located on the western edge of a promontory within the eastern part of the site.
- xxvi. To clarify the location and character of the supposed Roman cemetery found in the 19th century.
- xxvii. To look for evidence of Saxon or medieval settlement in the area north of the medieval moated platform at South Ockendon. Should it prove necessary to investigate the area of the moated platform, for which Scheduled Monument Consent will be required, to establish whether any Saxon, medieval or postmedieval remains survive below ground, and if so, to determine their character and state of preservation.
- xxviii. To look for any evidence that might assist in clarifying when the drainage of the Mar Dyke valley was carried out, and whether this was done all at once or over a long period of time.
- xxix. To establish the presence or absence of possible medieval or post-medieval drainage ditches within the western part of the site which may be associated with the scheduled medieval moat or a possible medieval or postmedieval watermill which was located on the south side of the medieval moat platform.
- xxx. To establish the presence or absence of the four medieval/post-medieval farmsteads which were located within the area of the site, one of these buildings may be extant at Hobletts Farm.
- xxxi. To establish the date of the possible medieval or post-medieval field boundaries that have been identified within the eastern and southern part of the site.
- xxxii. To investigate, characterise and date the regular areas shown on satellite photographs overlying the southern Mar Dyke palaeochannel north of Botney Farm and east of the modern track and field boundary crossing the existing watercourse.

3 Methodology

3.1 Constraints

- 3.1.1 Overhead power lines, buried services and ecological constraints are known close to the area, but Land Parcels 47 and 48f-h were only affected by ecological constraints adjacent to watercourses.
- 3.1.2 These limitations were considered when designing the detailed trench layout, but the plotted positions of field boundaries, watercourses and their associated ecological protection zones were only approximated at this stage. Consequently, it was necessary to adjust the locations of a small number of trenches by a few metres to accommodate these restrictions. The final layout of all trenches is shown in Figure 2.

3.2 Methodology for the evaluation

- 3.2.1 Due to the depth of sediments of known or suspected archaeological potential, the investigation used several targeted strategies, comprising standard 30m x 2m trenches up to 1m deep, deep trenches with stepped edges 30m x 6m and up to 2m deep, machine sampling of waterlogged and alluvial deposits in the ends of selected trenches up to a depth of 3m, and purposive boreholes at varying spacings to examine sediment sequences over 3m in depth. Trench 7 was 50m x 6m as it was positioned to straddle a narrow palaeochannel.
- 3.2.2 The total land parcel area was 38.38ha, and the area available for investigation excluding areas of services, hedgerows and other constraints was 32.68ha. A total of 123 trenches were excavated, with 45 trenches measuring 30m x 2m, and the remainder measuring 30m in length and up to 6m wide. Combined, these represent 4.5% sample of the area available for trenching. The locations of the trenches and the borehole transects are shown on Figure 2.
- 3.2.3 All trenches were located using a Global Positioning System (GPS) prior to machine excavation. All trenches were excavated using a tracked excavator fitted with a toothless bucket under constant archaeological supervision.
- 3.2.4 Revealed features were hand cleaned and sampled by hand excavation. They were recorded as outlined within the approved WSI. All finds were bagged by context throughout the evaluation and were recovered for further investigation, and soil samples were taken as appropriate.

4 Results

4.1 Introduction and presentation of results

- 4.1.1 The results of the evaluation are presented below and include a stratigraphic description of the trenches that contained archaeological remains. The full details of all trenches with dimensions and depths of all deposits can be found in Appendix A. Detailed finds reports and data are presented in Appendix B. Palaeo-environmental remains, scientific dating, human remains and geoarchaeological reports are presented in Appendix C.
- 4.1.2 Context numbers reflect the trench numbers, unless otherwise stated. For example, ditch 803 is a cut within Trench 8, while pit 1719 is a cut within Trench 17.
- 4.1.3 An overview of the results for the site is shown on Figures 3 and 4. Further detailed plans of the trenches which contained archaeological features and remains (flint scatters and waterlogged timbers) are shown on Figures 5-10. Selected sections are shown on Figure 11 and 12. The locations of the geoarchaeological transects are also included in Figures 2-4, and the transects themselves in Figures 14-20. Sediment profiles with radiocarbon dates are presented in Figure 21.

4.2 General soils and ground conditions

- 4.2.1 The soil sequence varied across the site but was broadly divided into two areas. The palaeochannels revealed deep sequences in excess of 3m comprising alluvial deposits of clay and peat horizons. The central and western part of Land Parcel 48 was undisturbed by palaeochannels and maintained a simpler sequence with the underlying geology of head or London clay overlain by a subsoil and then the ploughsoil. The subsoil was typically between 0.1m and 0.2m thick with a ploughsoil layer 0.3m thick.
- 4.2.2 Ground conditions throughout the evaluation were mixed as the fieldwork spanned a period of finer dry weather in the summer and then continued into more persistently wet weather in autumn. Conditions were also affected by the topography of the site with the trenches in the central and western areas typically being slightly higher than those to the north, east and south. There were also palaeochannels that meandered around the northern and north-east edge of the site and continued along the southern edge through Land Parcels 48g and 48f. The alluvial deposits exposed in these trenches were permanently waterlogged and as such the trenches rapidly flooded following machine excavation. Any trenches left open for several weeks tended to be impacted by a cycle of flooding and drying that led to the sides of the trenches cracking and collapsing.

4.3 General distribution of archaeological deposits

- 4.3.1 Archaeological cut features were limited to a small handful of trenches: Trenches 6, 13, 14, 19, 69 and 90. Trench 14 revealed a line of waterlogged wooden piles and Trenches 6 and 90 each contained unurned cremation deposits. Trench 13 contained an undated pit and Trench 69 an undated

posthole. Possible features were also recorded in Trenches 106 and 81, but were more likely of natural origin.

- 4.3.2 Trench 86 revealed a substantial scatter of *in situ* flint and other notable concentrations of flint were recorded in Trenches, 20, 25, 37, 72 and 90 with smaller individual numbers of flints in other trenches around the northern and eastern edges of the higher promontory. Pottery or fired clay was also recovered from layers in Trenches 22, 44, 60 and 97.

4.4 Trenches 6, 13 and 14 (Figs 5 and 11)

- 4.4.1 This group of trenches were located in the north-east corner of Land Parcel 48h. Trenches 6 and 14 had been positioned as part of a transect across the meandering palaeochannel, with Trench 14 located within and partly traversing the channel itself.
- 4.4.2 **Trench 6** revealed an unurned cremation in a small pit at the northern end of the trench (Plate 1). Pit 605 was 0.5m in diameter with steep sloping sides and an almost flat base, 0.12m deep. It contained a single deposit of charcoal rich silty sand, which was excavated and retained for processing (Samples 96, 101, 102 and 103). A small quantity of cremated human bone was recovered, including a fragment of cranium, although the overall assemblage was remarkably small with only 60.2g of bone recovered from the fill, 606. No artefacts were found in association with this feature, and the bone was insufficiently burnt to provide a radiocarbon date, but a fragment of roundwood charcoal from deposit 606 produced a radiocarbon date of 1100-900 cal BC (Beta 613902; 2830 ± 30BP).
- 4.4.3 Pit 605 was approximately 0.9m below ground level, cutting into weathered London clay. Overlying the pit was deposit 604, a leached silt horizon that was in turn sealed beneath alluvial layers 603, 602 and 601.
- 4.4.4 **Trench 13** was positioned approximately 65m to the south-west of Trench 6 and contained a small circular pit, 1311 (Plate 2). It measured 0.3m in diameter and 0.18m deep with steep sides and a narrow, rounded base (Fig. 11 Section 1302). It was filled with a deposit of charcoal-rich silt (1312) that included several fragments of calcined animal bone (Sample 143). No other finds were recovered from this feature and no adjacent features were observed.
- 4.4.5 The pit was recorded cutting through layer 1309, an alluvial deposit overlying the weathered bedrock. Overlying the pit and its fill was a leached horizon, 1308 that was in turn sealed beneath successive layers of alluvium, 1307, 1306, 1305, 1304, 1303, 1302 and 1301.
- 4.4.6 **Trench 14** lay immediately to the east of Trench 13. When the centre of the trench was machined below 1m, it revealed an alignment of six waterlogged timbers (Plate 3; Fig. 5). The timbers, which were originally recorded as postholes 1401, 1403-5, 1407, 1409 and 1421 containing posts 1402, 1404, 1406, 1408, 1410 and 1422 respectively, were found on a broadly north-south alignment down the length of the trench, but subsequent excavation showed that these were driven stakes and did not have postholes. 'Postholes' 1401, 1403, 1405 and 1407 were all exposed and recorded in plan (Plate 3). 'Postholes' 1409 and 1421 were revealed in the edge of the trench (Plate 4;

Fig. 11) and were therefore recorded in their entirety, timbers 1410 and 1422 being lifted and retained for further analysis (see Appendix B.5).

- 4.4.7 The stratigraphy of the trench comprised a sequence of alluvial layers up to 2m deep. It is difficult to determine the horizon from which the posts were driven into the alluvium and which layers have abutted them, though on balance, it appears as though these timbers were driven through deposit 1415. It is possible that they were driven from even higher in the sequence, but the fluctuating level of the groundwater would have prevented preservation at a higher level and no trace of a post-position was observed during machining.
- 4.4.8 The two recovered timbers were stakes sharpened to a point at the base, and suggest that all six timbers were driven into the alluvium. Timber 1422 (Plate 5; Fig. 13) was a radially cleft piece measuring up to 80mm wide and 1120mm long, worked to a point at the bottom end. Approximately 0.8m to the north was timber 1410, another radially cleft piece up to 100mm wide and 760mm long. The bottom end of this piece was also worked to a point (Fig. 13). Timber 1408 was some 3.85m to the north of 1410, possibly indicating that the stakes formed a line at irregular intervals, or alternatively that intervening stakes had rotted to below the level to which the trench was stripped at this point, and so were not seen. Recorded in plan the upper end was somewhat degraded but appeared to be a rectangular piece, perhaps boxed heartwood, or box halved measuring 158mm x 75mm. 1406 was a further 3.15m to the north and 1404 was another 0.85m. They were both roughly rectangular in plan measuring 80mm x 82mm and 64mm x 80mm respectively. Timber 1402 was a half rounded piece, 7.95m to the north of 1404. It measured 164mm x 85mm in plan.
- 4.4.9 A single struck flint was recovered from layer 1416 that accumulated around the stakes, and another came from ploughsoil 1400, but nothing sufficient to date the deposits. A sample of sapwood from timber 1422 was submitted for radiocarbon dating and produced a date of 680-450 cal BC (Beta 603776; 2460 ± 30BP).
- 4.4.10 The full extent of this line of timbers was not necessarily exposed within the area that was excavated, as the trench was not lowered to the level at which the timbers appeared in the step surrounding the deeper part of the trench. The LiDAR plot shown on Figure 5 is somewhat indistinct at this scale, but nevertheless indicates that Trench 14 did not catch all of the deepest part of the palaeochannel here, encompassing only its southern half. It is therefore also possible that the structure continued for a similar distance north of Trench 14.

4.5 Trenches 69, 86, 90 and 94 (Figs 6 and 10)

- 4.5.1 This group of trenches were positioned towards the south-east corner of Land Parcel 48h on the southern edge of the slightly raised promontory that occupied the centre of the parcel.
- 4.5.2 **Trench 69** revealed a small circular feature cut into the natural 6902 that may represent the remains of a pit or posthole. Feature 6905 measured 0.21m in diameter and just 0.05m deep with a shallow concave profile. It was filled with a sterile deposit of dark brownish grey, silty clay (6906). Due to the dimensions

of the feature and the lack of any other similar pits or postholes in the vicinity, it is possible this was just a naturally silted hollow.

- 4.5.3 Four struck flints including a Mesolithic/early Neolithic blade core and a sherd of later prehistoric flint-tempered pottery were recovered from the surface of the natural 6902 at the base of subsoil 6901. A further struck flint was also found in adjacent Trench 63 to the north.
- 4.5.4 **Trench 86** did not reveal any archaeological cut features but did contain the remains of a significant flint scatter (8603). Within test pit AAA at the western end of the trench, the weathered bedrock (8607) was revealed approximately 0.9m below ground level (Plate 6). It was overlain by 8606, a head deposit measuring up to 0.16m thick with an upper surface that sloped downwards to the southern corner of the sondage. Accumulated within the depression on the surface of 8606 was a layer of possible slope deposit 8605, that was in turn sealed beneath a mixed horizon or interface deposit, 8604. This mixed interface was present along the length of the trench beneath the subsoil and ploughsoil.
- 4.5.5 A total of 1314 worked flints were recovered from the trench, the majority of which, 1254 pieces, were excavated from a 1m² test pit AAA at the west end (Plate 7). A total of 10 spits containing struck flints, each approximately 50mm thick, were excavated through deposits 8604-8607 in this test pit. A second test pit (ADD) was excavated 20m to the north-east but produced just five pieces from the first spit was not continued. The overall composition of the assemblage is indicative of the late Mesolithic period with a strong proportion of blades and bladelets. These were accompanied by 15 microliths, 12 of which were backed bladelets. Also recovered from the trench were 17 sherds of early Neolithic pottery weighing 205g, which appear to represent approximately six different vessels. These were recovered from the upper spits (spits 1-3) in Test Pit AAA.
- 4.5.6 Although a large quantity of burnt flint was recovered from the assemblage and some 18% of the worked pieces showed signs of heating, no hearths were found. The deposits were also largely devoid of charred remains except for a few fragments of charcoal, an indeterminate grain from spit 1 of Test Pit AAA (Sample 100) and a fragment of hazelnut shell from spit 6 of the same test pit (Sample 134). Three small fragments of fired clay were also recovered from the scatter.
- 4.5.7 **Trench 90** was situated immediately to the south of Trench 86. Topsoil and subsoil sealed a 0.2m thick light grey sandy clay, leached horizon (9002). Two small scraps of middle Bronze Age-middle Iron Age pottery were recovered from this deposit, which overlay a head deposit (9003).
- 4.5.8 At the north-east end of the trench was a slightly irregular, sub-circular pit, 9007 (Plate 8). It measured 0.36m in diameter and 0.07m deep with shallow sides and concave base. Filling the pit was a charcoal rich deposit of silty sand (9008) with several pieces of calcined bone. A total of 14.8g of cremated bone was recovered from sample 57. This represents a particularly low quantity and due to the fragmented condition of the material no further information could be determined.

- 4.5.9 Towards the centre of the trench a linear soilmark 9005 cutting head deposit 9003 was tested. Excavation showed that this was irregular, and was probably a natural feature in the geology, but it produced a small assemblage of five worked flints. These formed part of a wider scatter of 21 flints identified along the surface of head deposit 9003 at the base of subsoil 9001. The surface flints were collected and attributed to context 9004 and their positions were recorded three-dimensionally. A further 8 flints were recovered from the subsoil, and were presumably derived from the same scatter.
- 4.5.10 Although a substantially smaller assemblage than that recovered from Trench 86, the 29 flints found in Trench 90 also had a high proportion of blades and the group is likely to be Mesolithic or early Neolithic in date.
- 4.5.11 **Trench 94** lay south of Trench 90, and below the ploughsoil contained a deep sequence of alluvial deposits, interspersed with buried soils and a leached deposit, on the south edge of the promontory adjacent to the east-west palaeochannel (For the full deposit sequence see Fig. 16 geoarchaeological Transect 4). Below the two uppermost alluvial deposits (9401 and 9402) was a leached silty sand deposit (9403) interpreted as brickearth, from which came a struck flint flake. This was probably peripheral to the scatters found in Trenches 86 and 90 to the north. A further derived flint flake came from the ploughsoil in adjacent Trench 93.

4.6 Trenches 20, 22, 24, 25, 26, 30, 37, 44 and 46 (Figs 3 and 4)

- 4.6.1 This group of trenches was located along the northern and eastern edges of the raised island or promontory with the paleochannel of the Mar Dyke recorded on a broadly E-W alignment to the north, and turning south at the east end. No archaeological cut features were encountered in any of these trenches, but struck flints were found in or upon layers within all of them.
- 4.6.2 In **Trench 20**, the bedrock was revealed at a depth of approximately 1m below ground level. This was overlain by alluvial brickearth-type deposits 2004-2006, followed by a leached horizon of pale grey clayey silt, 2003. Deposit 2002 was an alluvial layer of grey silty clay overlying deposit 2003, between 0.4m and 0.7m deep. Across the area of the trench a total of 75 worked flints were recovered from deposit 2002. These represent a mixed assemblage of Mesolithic and earlier Neolithic pieces alongside some probably later prehistoric material. Due to the chronological mixture of material and some slightly worn pieces this is likely to represent a minimally disturbed scatter rather than *in situ* material.
- 4.6.3 Deposit 2002 was overlain by a second alluvial deposit (2001), followed by the ploughsoil (2000). The deposit sequence is illustrated in geoarchaeological Transect 3 (Figure 15).
- 4.6.4 **Trench 22** lay 60m north-east of Trench 20 and south of Trench 14 (Figs 3 and 5). Overlying the bedrock (2210) and weathered bedrock deposits (2209 and 2208) was a sequence of alluvial layers interspersed with buried soils identified by their dark colour and humic character. The lowest alluvial layers were 2207 followed by 2206, then buried soil 2205, and then further alluvium 2204. None of these contained finds.

- 4.6.5 Layer 2204 was followed by a buried soil (2203), which produced a single flint flake, and over this was alluvium 2202, from which came seven flint flakes and a sherd of flint-tempered prehistoric pottery. There followed a final buried soil 2201, which was sealed by topsoil 2200. No struck flint were recovered from Trench 21 between Trenches 20 and 22, so these flints may indicate separate activity events.
- 4.6.6 **Trench 25** was located approximately 60m to the south-east of Trench 20. At a depth of 0.45m below ground level and overlying the weathered bedrock was a leached horizon (2502) which is likely to correspond with layer 2003 in Trench 20. This was overlain by an alluvial layer of brownish grey clayey silt (2501). A total of 15 worked flints were recovered from layer 2501, although they were noted to be concentrated towards the base of the deposit and may be disturbed from the surface of deposit 2502. The small assemblage was largely undiagnostic but did include both an early blade/bladelet core alongside more simple flakes and a flake with a denticulated edge, a type most common in the late Neolithic or Bronze Age.
- 4.6.7 Deposit 2501 was overlain by the ploughsoil which measured up to 0.3m thick.
- 4.6.8 **Trench 24** lay south-west of Trench 25 and south-east of Trench 20, on higher ground above the alluvial floodplain. Here a head deposit (2402) lay directly beneath the subsoil (2401), from which came six flint flakes and a tested nodule. These are likely to have been disturbed from the original ground surface by later cultivation. The assemblage was not of diagnostic date.
- 4.6.9 **Trench 30** lay south of Trench 26 and east of Trench 25, and on the edge of the alluvial floodplain. Below the ploughsoil was a single layer of alluvium (3001), and this overlies a leached horizon that overlies the weathered bedrock (3003). The leached horizon was a light brownish grey sandy silty clay (3002) with yellowish brown mottling and dark greyish brown veins, and this produced seven struck flints including a blade and a bladelet, possibly indicating an early group.
- 4.6.10 **Trench 37** lay south-east of Trench 30 towards the east edge of the site, where the palaeochannel ran south around the end of the island or promontory. This contained a deep sequence of alluvial deposits within which was a buried soil and a stabilisation horizon, the alluvium overlying a leached deposit (3708) on top of a brickearth type deposit (3709) and, at the base of the sequence, overlying the bedrock. The lower alluvial deposits (successively 3707, 3706 and 3705) all contained organic material but no finds. These were followed by a buried soil of strong brown clay without finds, and this was overlain by a further alluvium (3703), over which was a thin layer of greyish brown clayey silt with black charcoal (3702), interpreted as a stabilisation horizon. Thirteen struck flints consisting of 10 flakes, 2 blades and a chip were recovered from this deposit, as was a piece of briquetage. There followed one more alluvial layer (3701) and finally the ploughsoil. The deposit sequence is illustrated in geoarchaeological Transect 13 (Figure 19).
- 4.6.11 **Trench 46** lay south of Trench 37, and contained a similarly deep sequence of alluvial deposits that included a buried soil and a leached horizon over the natural. Below the uppermost two alluvial deposits (4602 and 4603) was a buried soil of grey clay (4604) from which a struck flint was recovered.

4.7 Trenches 44, 55 and 61 (Fig. 4)

- 4.7.1 These three trenches lay south of the trenches described above, on the promontory of higher and drier ground surrounded by the Mar Dyke palaeochannels. None contained clearly archaeological features, but each produced one or more struck flints from the surface of the natural below ploughsoil and subsoil, suggesting disturbed prehistoric activity in the vicinity.
- 4.7.2 **Trench 44** lay 60m west of Trench 46, 70-100m south of Trench 30 and a similar distance south-west of Trench 37, on the promontory of higher and drier ground surrounded by the Mar Dyke palaeochannels. Below ploughsoil and subsoil only a thin alluvial layer (4401) was seen above the natural gravelly clay (4402). Six struck flint and a fragment of fired clay were recovered from the surface of the natural, suggesting that there had been activity area in the vicinity that had been disturbed, possibly by the alluvial event. The flint included a flake core, possibly of the late Neolithic or Bronze Age. A struck flint was also recovered from the ploughsoil in this trench, as in adjacent Trench 45, indicating a background of dispersed flintwork.
- 4.7.3 **Trench 55** lay south-west of Trench 44, and here subsoil (5501) came directly down onto the natural. A struck flint was recovered from the surface of the reddish brown natural clay (5502). The natural was also cut by a tree-throw hole (5503), which was not further investigated.
- 4.7.4 **Trench 61** lay south-west of Trench 55, and here two layers of clayey sand with gravel were found below the subsoil and over the natural silty clay (6104). The upper of these two sand and gravel layers (6102) contained a flint flake, and another was recovered from the ploughsoil (6100).

4.8 Trenches 60, 72 and 96 (Fig. 7)

- 4.8.1 **Trench 72** was located at the eastern edge of the promontory against the eastern site boundary, 90m to the north-east of Trench 86. It was stripped to a width of 6m in anticipation of deeper excavation to 2m but revealed a concentration of worked flint. Approximately 0.55m below ground level was a leached horizon of light bluish grey sandy clay, 7206. It measured up to 0.12m thick and was present across the trench overlying the head deposit, 7207. The worked flints were predominantly recovered from the surface of deposit 7206 and were each recorded individually and assigned to scatter number 7205. A total of 50 pieces were recorded across the trench and a test pit (BAA) excavated at the southern end of the trench yielded a further 8 pieces. The assemblage appears to be a mixture of material with both Mesolithic or early Neolithic and later prehistoric technologies present.
- 4.8.2 Overlying 7206 were several shallow layers of alluvium followed by the subsoil and ploughsoil. The full deposit sequence is illustrated in Fig. 20, geoarchaeological Transect 14.
- 4.8.3 **Trench 96** lay south of Trench 72, and also contained a leached horizon (9602) over the natural, overlain by shallow alluvium (9601) under the ploughsoil (9600). The leached horizon (9602) was a light greyish yellow sandy silt, and produced two struck flints and some burnt flint. This may have been peripheral to the concentration in Trench 72.

4.8.4 **Trench 60** lay north-west of Trench 72 (Fig 7). There were no archaeological features in this trench, but there was a deep sequence of alluvial and other deposits. Below topsoil and the uppermost alluvium (6001) was an organic alluvial layer (6002), possibly equivalent to the organic horizons found further north and south and representing the Mar Dyke fen. Below this was a sequence of five alluvial deposits (6003-6007 in descending order), of which a sherd of Iron Age pottery was recovered from 6006. Below alluvium 6007 was a leached horizon (6008) from which came a worn struck flint. Below 6008 was a further alluvial deposit (6009) overlying head deposit 6010, the sequence bottoming on London Clay natural (6011).

4.9 Trenches 19, 81 and 106 (Figs 8-10 and 12)

4.9.1 As well as those already mentioned above, further undated archaeological features were identified within Trenches 19, 81 and 106. These trenches were dispersed across the site with Trench 19 towards the north-west, Trench 81 near the south-western edge and Trench 106 in the south-east corner.

4.9.2 **Trench 19** revealed a sub-ovoid shaped pit, 1904 (Fig. 8) cut through head deposit 1906 at a depth of approximately 1.1m below ground level. It was sealed beneath layer 1903, a leached horizon of light grey, slightly clayey sandy silt and subsequent layers of alluvium and humic-rich silts.

4.9.3 The pit measured 1.6m x 1.04m in plan with steep straight sides, 0.38m deep and flattish base (Fig. 12). Within the pit was a single deposit of dark greyish brown silty clay (1905), but no finds. Although the fill was dark in appearance, this was most likely to be derived from organic material as no charcoal was present in the deposit. The only find from this trench was a struck flint from the ploughsoil (1900).

4.9.4 **Trench 81** contained a NW-SE aligned ditch or gully 8104 (Fig. 9) cut through the natural geology 8102 and sealed beneath the subsoil and ploughsoil (Plate 9). It was slightly irregular in plan with step sides and a concave base, 0.7m wide and 0.31m deep (Fig. 12). It was filled with a sterile deposit of mid bluish grey silty clay that is likely to be alluvial in origin.

4.9.5 **Trench 106** revealed a sub-circular possible pit, numbered 10603 (Fig. 10), which was cut into the surface of leached horizon 10602 and sealed beneath alluvium 10601 (Plate 10). It was 2.2m in diameter and 0.32m deep with a shallow slightly concave base (Fig. 12). Filling the pit was a naturally accumulated humic deposit of dark brown, silty clay (10604). There were no finds.

4.10 Trenches 107, 109 and 110 (Fig. 4)

4.10.1 These were all trenches to the west of Trench 106 within the palaeochannel running east-west along the south side of the promontory (Fig. 4). All contained deep sequences of fluvial and alluvial deposits. The complete deposit sequences in Trenches 107 and 109 and their relative depths can be seen in Fig. 16, geoarchaeological Transect 4.

4.10.2 **Trenches 107 and 110** produced single struck flints from alluvial deposits 10707 and 11002.

4.10.3 **Trench 109**, unlike the other two, was located close to the south edge of the palaeochannel, and an olive brown clayey silt (10909) immediately above the natural contained both a struck flint and common burnt flint and charcoal, indicating activity derived from close by on the channel edge. This was overlain by a succession of alluvial layers interleaved with buried soils (successively 10908, 10904 and 10902). A complete left radius from a red deer (*Cervus elaphus*) was recovered from the middle buried soil (10904).

4.11 Finds summary

4.11.1 **Prehistoric pottery.** A total of 27 sherds weighing 231g were recovered from 7 trenches. The majority of the material came from Trench 86 and is early Neolithic, the remainder is later Bronze Age or Iron Age in date.

4.11.2 **Flint.** A large assemblage of 1580 worked flints and 814g (119 fragments) of unworked burnt flint was recovered from the site. A very large proportion of the flint, 1314 worked flints, making up 80 per cent of the entire assemblage, derived from a dense lithic scatter from layers exposed in Trench 86 on the higher promontory surrounded by the Mar Dyke palaeochannel, and probably extending south into Trench 90. This assemblage appears to represent a minimally disturbed, essentially single period assemblage of late Mesolithic date.

4.11.3 Two assemblages of more than 50 struck flints were also recovered from Trenches 20 and 72 on the north and east sides of the promontory, probably indicating further foci of activity of similar date. Much smaller assemblages of flintwork, some including a Mesolithic/earlier Neolithic blade-based component but also including simple flake-based material of probable late Neolithic to later Bronze Age/Iron Age date, were recovered from buried soils, stabilisation horizons and alluvial deposits along the northern side of the promontory, and a background of material was also recovered from topsoil and subsoil deposits across the evaluated area.

4.11.4 **Fired clay.** A very small quantity of fired clay amounting to 14 fragments weighing 136g was recovered from Trenches 44, 84 and 86. A perforated plate from context 4402 can be dated to the late Bronze Age, the rest of the fragments cannot be dated due to an absence of diagnostic material.

4.11.5 **Briquetage.** A single 4g fragment of briquetage vessel was found, in context 3702.

4.12 Environmental summary

4.12.1 **Charred plant remains and charcoal.** Twenty-two bulk samples were taken from the evaluation. The samples did not provide much charred material, and were mostly of limited potential, but this is a reflection of the small number of cut archaeological features or layers with clear charred plant remains potential that were encountered.

4.12.2 **Waterlogged plant remains.** In addition to the samples taken from dry deposits, 53 samples were taken from organic, waterlogged deposits. The flots from this site vary considerably in terms of volume and abundance of preserved plant and insect remains although overall the preservation of seeds is good. Insect remains were generally fragmentary although occasional smaller specimens remained intact, and elytra are present in many samples.

Snails are not present in any of the flots, which is typical for peaty deposits. Flecks of charred plant material, particularly charcoal, occur in several flots but were not suitable for further identification.

- 4.12.3 **Animal bone.** Faunal remains were recovered from just two contexts. A complete left radius from a red deer (*Cervus elaphus*) was recovered from context 10904 and a residue from sample 143, context 1312 produced over 100 comminuted, calcined fragments of indeterminate mammal bone.
- 4.12.4 **Human remains.** Two unurned cremation deposits (605 and 9007), were recovered from the site. The bone weights were very low at a total of 60.2g for deposit 606 and 14.8g for deposit 9008, they were also highly fragmented and consequently just one cranial vault was identified from deposit 605. Charcoal from the cremation in 605 was radiocarbon-dated to 1100-900 cal BC (Beta-613902; 2830 ± 30 BP).
- 4.12.5 **Radiocarbon dating.** Twenty samples were submitted for dating: one charcoal from a human cremation, one from a worked wooden timber, six waterlogged seeds and twelve paired humic and humin fractions of organic sediment. The charcoal, wood and waterlogged seeds all produced reliable dates, but the paired humic and humin samples gave dates that were statistically inconsistent. The paired dates were all, however, stratigraphically consistent.
- 4.12.6 **Foraminifera/ostracods.** These proved to be absent from all of the 9 submitted samples, but water flea (*Cladocera*) and their ephippia (eggs) were common, indicating that seawater had not reached this far up the Mar Dyke river at these times.
- 4.12.7 **Diatoms.** Of 13 samples submitted, 5 had diatoms sufficient for full assessment, and another 6 included diatoms in smaller numbers. No diatoms of saline environments or marine planktonic taxa were found, all the diatoms present being of types suggesting a freshwater environment, a conclusion supported by the chrysophyte cists and testate amoebae that were also found.
- 4.12.8 **Pollen.** Pollen was well-preserved in the waterlogged samples, and provided evidence of good recovery through a depositional sequence ranging in age from the early Bronze Age to the late Iron Age or Saxon period. Assessment has suggested dominance of lime woodland during the early Bronze Age, followed by a probable lime decline, together with expansion of open areas. Evidence from pollen and NPP data supports use of the land for pastoral and probable arable farming, during the middle and late Bronze Age. Local environments, inferred from pollen assemblages, include sedge fens and wetland areas capable of supporting aquatic plants. At some point within the later Iron Age to Saxon periods, there is expansion of sedge fen communities, which may reflect higher water-tables, and possible re-growth of hazel-type scrub. No evidence of marine environments was recorded.

5 Discussion

5.1 Reliability of field investigation

- 5.1.1 The layout of trenches provided a fair overall coverage of the site. However, across the areas of anticipated alluvium and associated palaeochannels the trench layout was more targeted, meaning that some areas were investigated by fewer and more widely spaced trenches. It is also true that some of the trenches did not expose the full sequence of Holocene deposits, with only 26 of the trenches intended for excavation to 3m were excavated to full depth.
- 5.1.2 Water ingress was a consistent problem in the northern and southern areas of the site with constant flooding leading to the collapse of some trench edges and hindering safe access and the visibility of deposits. In some instances, this meant that the trenches were not entered and the sequences were recorded from outside of the trench. The overall impact of this was limited, as only a small number of trenches needed to be recorded in this manner.
- 5.1.3 The few archaeological features that were found were easily identified against the underlying Head deposits. Furthermore, a number of other deposits were sample-excavated to establish if they were of geological or archaeological significance, and these were generally shown to be variations in natural deposits or pockets of alluvium.
- 5.1.4 The identification of archaeological activity within floodplains and palaeochannels is a great deal more difficult than identifying features on dry ground, whether this be surface spreads and features on stabilisation horizons and buried soils on the floodplain, or waterlogged wooden structures and artefacts within the channels. The recognition of a flint scatter below alluvial deposits in the east and within them in the northern parts of the site respectively demonstrates the success of the evaluation in this respect, as does the recognition of a wooden structure in the north. The ingress of groundwater was generally confined to the deeper (and earlier) alluvial deposits, limiting the ability to identify activity in the earlier parts of the potential archaeological sequence.

5.2 Interpretation

- 5.2.1 The evaluation set out to investigate an island of higher ground within the Mar Dyke valley that LiDAR data suggested was surrounded by palaeochannels of the Mar Dyke river. The results of the trenching and borehole investigation on the western side of the 'island' (Fig. 14, geoarchaeological Transect 2), showed that, although Pleistocene/late Glacial activity had removed a shallow depth of material, bedrock was reached at shallow depth, and only a single thin deposit of alluvium occurred, in contrast to the deep sequences of fluvial and alluvial deposits found on the north, east and south. In consequence, the 'island' should more accurately be described as a promontory extending from the higher ground to the west of the valley (Appendix C.9), and will be referred to as such in the following discussion.
- 5.2.2 **Late Upper Palaeolithic/early Holocene.** No archaeological finds of this period were identified, but an organic deposit within brickearth in borehole

OCAWS307 was radiocarbon dated to one or other of these periods (Appendix C.5).

- 5.2.3 **Mesolithic and early Neolithic.** Later Mesolithic activity on the site is most clearly demonstrated by the large assemblage of worked flints recovered from Trench 86. The flints include a high proportion of blades as well as microliths, microburins and a tranchet axe/adze sharpening flake that are all typical of this period. Furthermore, the preponderance of narrow backed bladelets appears to match that found in other assemblages from the south-east of England that have been dated to the earlier part of the late Mesolithic (Appendix B.1). No hearths were found in association with this activity, but burnt flints suggest that these may be present outside the area of the trench.
- 5.2.4 The majority of the assemblage was recovered from a sequence of deposits located at the western end of the trench that were up to 0.5m thick. These comprised a combination of weathered bedrock, Head and slope deposits. Due to the limited window of investigation it is unclear precisely how these deposits were formed, but the contours of these layers indicated that they were sloping into and filling a former depression extending beyond the trench, probably a broad shallow gully formed by water draining from the higher ground to the north.
- 5.2.5 Seventeen sherds of early Neolithic pottery probably from six vessels were also recovered from the uppermost part of sequence and from the wider surface within the trench, demonstrating continuing activity here in the early Neolithic period. Despite the Mesolithic date of the diagnostic pieces in the flint assemblage, it is quite likely that a proportion of the flintwork in the uppermost part of the deposit sequence was also of early Neolithic date, as the technology of flint manufacture in both periods is similar.
- 5.2.6 A second test pit at the east end of Trench 86 provided far fewer flints, but this, and a smaller assemblage of flint from Trenches 90 to the south, plus a few flints from Trench 69 to the north, indicate a fairly extensive area of activity overall. Given the low number of well-preserved Mesolithic flint concentrations ('scatters') previously identified in the region, the Mesolithic scatter in itself represents a site of regional importance. Although the Mesolithic and early Neolithic activity might have been distinct and unrelated, it is also possible that this site represents the Mesolithic-Neolithic transition, a period of particular importance for understanding the past in Britain.
- 5.2.7 Trenches 20 and 72 on the northern and eastern edges of the promontory floodplain also produced reasonable assemblages of worked flint that included material of diagnostically Mesolithic date, suggesting that further concentrations of activity exist in the vicinity of these trenches. Some material that is likely to be later also came from Trench 72. Few struck flints were found in the trenches adjacent to Trench 72, probably indicating that this was a smaller focus of activity than that at Trench 86. Smaller assemblages of struck flints were, however, found in many of the trenches east of Trench 20, suggesting a widespread zone of activity along the edge of the floodplain and on the edge of the adjacent promontory (Fig. 3).
- 5.2.8 One of the trenches just to the south on the higher ground of the promontory here also contained a group of struck flints, and it is unclear whether the apparent concentration of evidence on the floodplain edge is because this

topographical zone facilitated preservation, or whether the edges of the promontory, nearer to the former channels of the Mar Dyke, were favoured locations. Either way, these peripheral areas should be considered as being likely to contain significant assemblages of flint. These may take the form of further large concentrations of flintwork in the areas between the trenches, or may instead represent activity of a different sort in this zone, consisting of smaller foci of specific activities across a wide area, similar to the Mesolithic activity found at the Eton Rowing Course alongside a palaeochannel of the Thames (Allen *et al.* 2013, 58-85).

- 5.2.9 The recovery of early Neolithic pottery and flintwork demonstrates that this activity probably continued in a similar manner into this period. Although no diagnostically early Neolithic tool types were found, most of the smaller groups of flint could be of early Neolithic rather than Mesolithic date, and a pattern of both large-scale and smaller-scale widespread flintworking activity was also recovered at the Eton Rowing Course floodplain in the middle Thames Valley (*ibid.*, 261-284). No environmental deposits of Mesolithic or early Mesolithic date were identified to accompany the dry land evidence in the areas targeted for environmental transects, although in a meandering river system these may well have survived scouring by later channel activity in places along the river system.
- 5.2.10 **Bronze Age to Iron Age.** Distinctly late Neolithic or early to middle Bronze Age features and finds were largely absent from the site, although one denticulated flake from Trench 25 is a type characteristic of the Bronze Age. Although elements of the flint scatters, particularly that in Trench 72 do contain material that is broadly attributable to the later prehistoric period they cannot be defined further than this. Similarly, some of the less diagnostic sherds of late prehistoric sherds of pottery can only be broadly attributed to the middle Bronze Age/middle Iron Age period.
- 5.2.11 The perforated plate from a portable oven or hearth found in Trench 44 is dated to the late Bronze Age and provides one of the few diagnostic artefacts for this period. A small group of struck flint flakes and a core were also found in this trench, and together they may represent a short-lived focus of activity. A fragment of briquetage recovered from a layer in Trench 37 may have been of similar date, but as it had no diagnostic traits it could be later.
- 5.2.12 Charcoal from the unurned cremation in Trench 6 produced a late Bronze Age date. The placing of this cremation is important for two reasons. Its stratigraphic position, cut into London Clay below a sequence of alluvial deposits towards the edge of the valley base, indicates that this area was at least seasonally dry in the late Bronze Age, and could indicate that the alluvial floodplain was much less extensive at this time. It is therefore possible that further burials will be found below alluvium around the edges of the floodplain, at least in this part of the site. The burial was also made close to a promontory of higher ground extending westwards into the Mar Dyke valley, upon which a curving earthwork has been recognised that could be of prehistoric origin, although surviving until the present day.
- 5.2.13 Although the second cremation in Trench 90 was not dated, it may also have been of later prehistoric date. The WSI (Oxford Archaeology 2021) highlights the increasing evidence for deliberate deposition of human remains in and

around wetland environments. The discovery of two cremations from this site supports this assertion and further remains should be considered likely. The combined evidence from the scattered findspots and the cremations suggest a somewhat ephemeral phase of activity during the late Bronze Age that is difficult to define, but nevertheless present.

- 5.2.14 The environmental evidence from the palaeochannel system starts in the early Bronze Age, and well-preserved deposits are found thereafter throughout the Bronze Age and most of the Iron Age.
- 5.2.15 South of the promontory the main west-east palaeochannel was investigated by both trenches and a line of boreholes (Transect 4), but the investigation of the deepest deposits within the channel was limited to the boreholes, as the trenches were not excavated below a depth of 2m. Transect 4 demonstrated that the palaeochannel was generally 1.8m-2.0m deep, with two deeper incisions on the north and south edges, that on the north 2.8m deep, that on the south up to 3.3m deep. Organic sediment from 1m above the base of the southern channel was radiocarbon dated to the early Bronze Age, 2200-1970 cal BC (Beta-617522; 3700 ± 30 PB) and 1890-1680 cal BC (Beta-617521; 3450 ± 30 BP), and sediment from the base of the northern channel to the middle Bronze Age, 1510-1400 cal. BC (Beta-617519; 3180 ± 30 BP). Pollen indicates a predominance of trees in the early Bronze Age, consisting primarily of lime, hazel and alder, with open grazed areas. By the middle Bronze Age pollen suggests increased clearance and the colonisation of the channel fringes by bulrush, and the seeds are of plants of slow-moving water at the channel banks.
- 5.2.16 In both cases over 1m of sediment had accumulated by the late Bronze Age, dates for which were 910-800 cal BC (Beta-617520; 2690 ± 30 BP) and 930-810 cal BC (Beta-617518; 2730 ± 30BP), by which time the deeper channel incisions had been filled, and sediments now spread across the full width of the palaeochannel. Pollen suggests a further reduction in woodland cover and expansion of open areas, and some cereal grains suggest an element of arable farming. By this stage the sediments were either peaty or heavily organic, indicating slower flow, and this is borne out by the environmental evidence. This continued, with only a couple of interruptions of increased flow leading to alluviation, into the early Iron Age, where the top of the peat was dated to 750-400 cal BC (Beta-617529; 2430 ± 30 BP). Pollen evidence suggests a further reduction in tree cover to 12%, and an expansion of grassy or meadow areas in a sedge-fen environment, although disturbed ground and possible arable cultivation are also suggested.
- 5.2.17 Two principal borehole transects and a series of trenches were dug across the palaeochannels north of the promontory (Transects 3 and 5, Figs 15 and 17), although the deepest deposits were mainly investigated by boreholes, as few trenches were dug beyond 2m deep. Transect 3 identified two palaeochannels, the northern one up to 2.8m deep, the southern one up to 3.1m deep, within a wider alluvial floodplain with an average depth of 1m. Transect 3 confirmed that preservation of waterlogged and pollen material was good, but did not date the palaeochannels, although the more southerly channel appears to be the same as that recorded further east in Transect 5 (Fig. 2). The boreholes of Transect 5, which ran alongside Trench 14,

confirmed the LiDAR evidence that the deepest part of the palaeochannel here (up to 3.5m) lay just north of the trench, and radiocarbon dating provided a middle Bronze Age date of 1380-11210 cal BC (Beta-617517; 2990 ± 30 BP) for the second fill close to the base of the channel (Appendix C.5). A series of organic silts accumulated to a depth of 1.5m above this by the early Iron Age, represented by a radiocarbon date of 790-540 cal BC (Beta-617532; 2520 ± 30 BP). The environmental evidence from the Bronze Age deposits in these transects is similar to that south of the promontory, and the waterlogged seeds and pollen from the early Iron Age horizon similarly suggest that by this time the channel was slow-flowing and vegetated with sedges and rushes (Appendices C.2, C.9). The broad picture provided by the transects is of a common palaeochannel sequence in terms of chronology and character both north and south of the promontory, with no indications of earlier deposits.

- 5.2.18 No artefactual dating was available to enhance the radiocarbon sequence either north or south of the promontory until this time, but during the early Iron Age a line of wooden stakes was driven into the palaeochannel fills in Trench 14 on the north. Timber pile 1422 from Trench 14, one of a line of six, was radiocarbon dated to the early Iron Age, and it is reasonable to assume that all of the adjacent piles were contemporary and part of the same structure. The function of the structure is unclear as its full extent was not established either in terms of its overall length nor whether it comprised just a single row of piles or if others exist beyond the limits of the excavation. The uneven spacing of the stakes may be illusory, as some timbers may have survived at different heights to others. The stakes are of comparable size to earlier, Bronze Age structures found in the lower Thames Valley at Freemasons Road on the A13 and in the Ebbsfleet valley in north Kent (Stafford *et al* 2012, 135-9), which were both interpreted as footbridges. Hardly any comparable early Iron Age structures are known in the region, but a group of linear structures of this date crossing a palaeochannel of the Thames were excavated at the Eton Rowing Course in the middle Thames valley, (Allen *et al.* forthcoming), and were also interpreted as bridges. The evidence from the adjacent trenches and the lidar data (Fig. 3) shows that this position was one of the narrowest points of the palaeochannel and would therefore have been a good location to cross the Mar Dyke. It is therefore possible that these timbers formed part of a bridge-like structure.
- 5.2.19 The Bronze Age examples cited above apparently stood alone in their landscapes, but at the Eton Rowing Course a series of five such structures of early or middle Iron Age date were found along the palaeochannel, raising the possibility that there may also be other such structures along the palaeochannel in the Mar Dyke valley
- 5.2.20 Aside from a few poorly dated scraps of pottery, these timbers form the only evidence for Iron Age activity on this site, although late prehistoric activity was recorded on the promontory in the adjacent Land Parcel 45b within this project (OCA 2022a), immediately west of the Mar Dyke and approximately 330m to the south-west of Trench 14. This comprised a combination of posthole structures and associated ditches in Trenches 452, 454 and 455, and provides good evidence for settlement along the west side of the Mar Dyke floodplain adjacent to this site. It is possible that this activity could have extended into the western edge of Land Parcel 48h prior to the straightening and

canalisation of the Mar Dyke river, but no trace of further activity was found in the few trenches excavated at the edge of the straightened Mar Dyke here. A further radiocarbon date of the middle-late Iron Age, was obtained from the peat overlying the surviving timbers in Trench 14.

- 5.2.21 **Roman.** No Roman features or finds were recovered from the site. Although Roman agricultural activity has been recorded in the fields to the south and north-west of the site (OCA 2021; 2022a), along with settlement evidence on the gravel ridge to the south, no Roman features were revealed during this investigation.
- 5.2.22 **Saxon/early medieval.** A thin layer of peat that was observed over many of the trenches in the palaeochannel areas of the site was radiocarbon dated in Trench 14 to cal AD 700-950 (Beta-617526; 1200 ± 30 BP) and cal AD 880-1020 (Beta-617525; 1100 ± 30 BP), and to 160 cal BC – cal AD 70 (Beta-617528; 2040 ± 30 BP) or cal AD 600-760 (Beta-618695; 1380 ± 30 BP). The differing dates for each location are the humic and humin fractions of the sediment. Although there is divergence between the fractions, the sample dated from Trench 14 is consistently of Saxon date, and this is probably when the Mar Dyke fen first appeared.
- 5.2.23 **Medieval and post-medieval.** Medieval and early post-medieval evidence is absent from the site. During these periods the site, or Orsett Fen as it was known, would presumably have been unsuitable for settlement or farming during the historic period.
- 5.2.24 It is likely that agriculture could only recommence on the floor of the Mar Dyke basin only as a result of canalising the Mar Dyke and implementing a series of drainage measures during the 19th century.
- 5.2.25 A layer of made ground recorded in Trench 8 below the ploughsoil is likely to be upcast material related to the canalisation of the Mar Dyke. This formed part of an earth embankment along the eastern edge of the watercourse. Whilst it is assumed that this was constructed during the late 17th or 18th century, in line with historic mapping, no supporting evidence was recorded during the evaluation. No drainage ditches were marked on historic maps within the area of the site, other than those between the land parcels, which were not evaluated as they still carry water. No further evidence of former drainage of the site was found by the trenching.
- 5.2.26 **Undated features.** The charcoal-rich pit in Trench 13 and the larger sterile pit from Trench 19 contained no dating evidence. Given the small number of archaeological features across the site, it is difficult to ascribe these features to any particular phase of activity and they bear no obvious association with any of the adjacent activity.

5.3 Evaluation objectives and results

- 5.3.1 **Aim i.** This evaluation established the presence of archaeological remains from the Mesolithic, early Neolithic, late Bronze Age and Iron Age periods, and of well-preserved environmental remains from the early Bronze Age to the end of the Iron Age. A pattern of flintworking was recognised along the northern, eastern and southern edges of the promontory extending into the middle of the site from the west. Early Neolithic pottery also indicates the likelihood of domestic activity in that period.

- 5.3.2 Activity in floodplain and palaeochannel environments is often focussed on small areas, and it is therefore particularly difficult to determine whether areas between blank trenches are genuinely without archaeology. The presence of a cremation burial below alluvium warns against assuming that areas of alluvium, even if themselves without archaeology, do not seal buried features. There remains significant potential for further flint scatters, hearths and waterlogged structures within the floodplain and palaeochannel areas of the site. On the higher, drier ground, the evaluation has established the general paucity of cut archaeological features, although the presence of struck flints around the periphery is clear, and this zone is likely to contain further archaeological remains.
- 5.3.3 **Aims ii, iii and xxii.** Crop marks are generally absent from the low-lying parts of the Mar Dyke valley. The absence of these was conformed by the results of the evaluation where cut features that may otherwise show as cropmarks were generally sparse and limited to discrete features. The larger palaeochannels indicated by geophysical survey and by LiDAR data have been confirmed by trenching.
- 5.3.4 **Aim iv.** The complexity of the stratigraphy has been established across the site with areas of deep deposit sequences and palaeochannels clearly identified. Areas where buried archaeological horizons exist or have the potential to survive have also been identified, particularly along the edges of the promontory and extending out into the alluvial floodplain.
- 5.3.5 Overall, there were very few cut archaeological features, but this may be a consequence of the nature of occupation and activities in a low-lying floodplain and palaeochannel context. Horizons of human activity on the floodplain and waterlogged wooden structures within the palaeochannel deposits have been located, demonstrating exploitation of this low-lying environment during later prehistory. The potential for the preservation of multiple flint scatters and waterlogged timber structures and objects within the palaeochannel and alluvial sequences is high.
- 5.3.6 **Aims v-vi.** The evaluation has established the date of some of the remains present, but the absence of diagnostic tools from many of the smaller flint assemblages has made it impossible to date these except very broadly. The state and preservation of the archaeological artefacts has been assessed. Evaluation in low-lying landscapes cannot easily provide information about the economy and status of prehistoric activity, as this is of a different character to that provided by pits and enclosures of settlement on dry ground. Where waterlogged structures are present there are often objects deliberately deposited in the palaeochannels adjacent, for example at Fiskerton, Lincolnshire (Field and Parker-Pearson 2003), and at Flag Fen (Pryor 2002). The scale of investigation at evaluation stage and the very localised nature of these events means that it is very unlikely that these will be encountered other than through chance and their absence from the evaluation results should exclude the potential for these to exist.
- 5.3.7 **Aim vii.** Extensive paleoenvironmental sampling was undertaken to characterise the floodplain and palaeochannels, and assessment has demonstrated good preservation of waterlogged plant remains and pollen, together with reasonable preservation of insect remains, diatoms and other

microfauna, indicating a high potential for environmental information. The paucity of archaeological features resulted in few dry land samples, although good preservation of charcoal has been found in the cremation deposits.

- 5.3.8 **Aim viii.** The borehole transects and the trenching. Together with targeted radiocarbon dating, has enabled the construction of models for the development of the palaeochannels and surrounding floodplain. The deposits examined in evaluation appear to be mainly of Bronze Age and later date, with two main palaeochannels so far identified within a meandering system that was silting up by the end of the Iron Age, and became a fen in the Saxon period.
- 5.3.9 **Aim ix.** The survival of a minimally disturbed later Mesolithic scatter with an early Neolithic element represents a discovery of regional significance, as does the evidence indicating the potential for further similar discoveries. A site of this nature has considerable potential for contributing to the regional research objectives in terms of understanding this period, and in particular gaining the insights into the development of narrow blade technologies and the late Mesolithic to early Neolithic transition.
- 5.3.10 The early Iron Age timber structure is also a regionally important discovery, as other structures found in the lower Thames have been almost entirely of earlier or later periods. Further excavation would contribute to our understanding of technology, woodland management and landscape use during this period. The structure also demonstrates the potential for further structures to be present within the Mar Dyke palaeochannels. Evaluation at the Eton Rowing Course in the middle Thame Valley revealed only two potential structures separated by over 1km, but excavation resulted in the recovery of six major structures and numerous smaller ones (Allen *et al.* forthcoming).
- 5.3.11 **Aim xiii.** The evaluation was conducted within the parameters and objectives of the revised East of England Research Framework (Medlycott 2011) and takes account of the aims and objectives of the Greater Thames Estuary Historic Environment Research Framework.
- 5.3.12 **Aim xiv.** The few archaeological features identified on the site were typically associated with and sealed beneath a leached horizon, which in places was sealed beneath alluvium. Many of the flint scatters and groups were also associated with this horizon, although some were also found on horizons within the alluvial deposits themselves. A preserved waterlogged wooden structure has been identified within the palaeochannels.
- 5.3.13 **Aim xv.** The evaluation was targeted on very late Pleistocene and Holocene deposits, although broad characterisation of earlier deposits has also been provided. Current evidence has tentatively suggested that the Mar Dyke valley is largely of late Pleistocene date, but no scientific dating has yet been carried out upon the Pleistocene sediments, nor have these been studied by the LTC geoarchaeological and Palaeolithic consultants.
- 5.3.14 **Aim xvi.** The evaluation has identified two palaeochannels both north and south of the promontory, and has dated one of those on the north and both of those on the south to the Bronze Age. The deposits examined in both areas appears to follow a similar sequence in terms both of sediments and

environmental development. It has not, however, been possible at evaluation stage to trace the course of these palaeochannels in detail, nor to demonstrate the date of all of the elements of what is a complex meandering channel system, and localised survival of earlier deposit sequences within such a system might be expected.

- 5.3.15 **Aim xvii.** No evidence of successive preserved sequences of channel deposits were identified by the evaluation. The relatively small number of trenches that were dug below 2m, however, and the consequent reliance upon borehole (i.e. point) data, makes it impossible to be certain that this is an accurate reflection of the channel complexity, and localised survival of earlier deposit sequences within such a system might still be expected.
- 5.3.16 **Aim xviii.** The areas along the edge of the palaeochannels appear to have been the focus for activity in the past. Although worked flint was recovered from across the site, the densest scatters were found in trenches closest to the palaeochannels. Particularly to the north and east of the site these were associated with a leached horizon and alluvial deposits suggesting these were probably at least seasonally inundated, or perhaps there was a more long-term shift in the movement of water over time. The two cremations were also located at the edges of the channels and although these are likely to represent a different phase of activity to the flint scatters, they demonstrate a repeated focus.
- 5.3.17 The overall pattern of evidence, with numerous surface finds of various types and a general lack of features would suggest that the use of this environment was more intermittent than permanent, although the evidence of activity throughout much of the prehistoric period, including the construction of a timber bridge and the two cremations demonstrate that this was an important and active environment.
- 5.3.18 **Aim xix.** Few artefacts were recovered from the palaeochannels. This is mostly likely to reflect an absence of material but equally the overall evaluation conditions of the palaeochannels were not conducive to artefact recovery. Within peat deposits most artefact types tend to become stained and a similar colour to the sediments and identification is difficult. Systematic sampling of the waterlogged deposits allowed ecofacts to be more readily identified and their state of preservation was shown to be good.
- 5.3.19 A line of timber piles representing part of a timber structure was found in Trench 14. These were reasonably well preserved, although their upper parts (above the permanent water table) have rotted away, as is usual with such structures. They may represent part of a footbridge over one of the palaeochannels at this point.
- 5.3.20 **Aim xx.** No evidence of saltwater was recovered from the environmental samples taken from the site, suggesting that marine incursion did not reach this far up the Mar Dyke river after the early Bronze Age.
- 5.3.21 **Aim xxi and xxiii.** The evaluation has demonstrated use of the site in the later Mesolithic and early Neolithic periods. Evidence of Mesolithic and early Neolithic activity in the immediately surrounding area is slight, but in the early Neolithic period a possible long barrow has been identified 0.8km to the south-west of the site, and if genuine, this may well have been used by those using

the site. In the same period a causewayed enclosure was established at Orsett 3.8km to the south-east, and exploitation of the low-lying valley from there would not be an excessive distance to travel by a population that was still seasonally mobile in this period. For the later prehistoric period, the cremations found may be related to scattered activity found to the north-west on the higher parts of the valley (OCA 2022a), but due to the absence of closer dating of the pottery from there, this remains uncertain. The early Iron Age structure is likely to relate to activity identified in Land Parcels 46 and 45B to the north-west and west, or to the recently evaluated settlement at Bulphan Fen 1.5-2km to the north (Cotswold Archaeology 2022), though the nature of the activities undertaken on the floodplain and in the river channels is still unclear.

- 5.3.22 **Aims xxiv-xvii, xxix, xxx and xxxi.** All of these are outside the site that was evaluated for this report. One of the rectilinear enclosures has been investigated and reported upon already (OCA 2022a), as have the post-medieval boundaries in the southern part of the Mar Dyke (OCA 2021); the other sites are outside the areas likely to be impacted by the scheme.
- 5.3.23 **Aim xxviii.** Although the latest date obtained for the widespread peat formation across the site was at the end of the Saxon/early medieval period, there is was no evidence of medieval or early post-medieval activity to conclusively demonstrate when or if drainage took place during these periods. No significant systems of former drainage ditches were encountered and it is probable that the existing drainage systems are part of the original drainage event. The layer of made ground in Trench 8 is likely to represent upcast from the Mar Dyke channel, although no dating evidence is associated with this layer and it cannot be determined if this was generated during the initial excavation of the channel or if it relates to subsequent maintenance and dredging.
- 5.3.24 **Aim xxxii.** The regular areas shown on satellite photographs overlying the southern Mar Dyke palaeochannel north of Botney Farm are not archaeological in origin. The darker patches of vegetation were the result of track matting laid down to drill boreholes at this location prior to the evaluation.

Appendix A Trench Tables

Trench 1							
General description					Orientation		NW-SE
Trench devoid of archaeology. Consists of ploughsoil overlying alluvium, sealing a stabilisation horizon. Below this a further four alluvial deposits varying in organic content. This overlies a leached horizon and several weathered bedrock layers. In section 101 another organic alluvium is under the leached horizon and weathered bedrock 111) possibly only visible as a thin band. Below this in the entire trench a further two bedrock, one weathered and one possibly natural. Excavated to a total depth of 2m.					Length (m)		30
					Width (m)		6
					Avg. depth (m)		1.4
Context No.	Type	Fill Of	Width (m)	Depth (m)	Description	Finds	Date
100	Layer			0.25	Ploughsoil. Dark grey brown, silty clay. Mottled occasionally with mid yellow		
101	Layer			0.21	Alluvial Layer. Mid greyish brown mottled by a mid-yellowish brown. Slightly silty clay.		
102	Layer			0.02	Other Layer. Organic, black slightly peaty silt.		
103	Layer			0.13	Alluvial Layer. Mid yellowish brown mottled by a mid-grey. Silty clay.		
104	Layer			0.16	Alluvial Layer. Organic alluvium, dark greyish brown with a strong brown band in centre. Slightly peaty silt.		
105	Layer			0.04	Alluvial Layer. Mid grey mottled by mid reddish brown. Slightly silty clay.		
106	Layer			0.11	Alluvial Layer. Humic alluvium, Mid greyish brown mottled with dark greyish brown. Silty clay.		
107	Layer			0.26	Other Layer. Leached horizon. Pale greyish brown mottled by mid reddish brown. Silty clay.		
108	Layer			0.12	Alluvial Layer. Pale bluish grey mottled by black sediment (mostly waterlogged plant roots in situ) slightly silty clay.		
109	Layer			0.39	Natural. Weathered bedrock. Mid greyish brown mottled by a mid-bluish grey. Silty clay.		
110	Layer			0.14	Natural. Mid greyish brown. Silty clay with 5% mid bluish grey mottling.		
111	Layer			0.25	Night Soil. Weathered bedrock. Mid reddish brown mottled by a pale grey. Slightly silty clay.		
Trench 2							
General description					Orientation		E-W
Trench devoid of archaeology. Consists of ploughsoil and two underlying alluvial deposits, then a stabilization horizon above two underlying alluvial layers, then a peaty layer and several alluvial deposits above a base of weathered bedrock. Sondage excavated to 3m at East-end.					Length (m)		30
					Width (m)		6
					Avg. depth (m)		2
Context No.	Type	Fill Of	Width (m)	Depth (m)	Description	Finds	Date
200	Layer			0.19	Ploughsoil. Dark grey brown, silty clay.		
201	Layer			0.1	Alluvial Layer. Oxidised Mid reddish yellow clayey silt.		

202	Layer			0.2	Alluvial Layer. Mid brownish grey clayey silt.		
203	Layer			0.06	Buried soil. Dark greyish brown silty clay.		
204	Layer			0.15	Alluvial Layer. Oxidised dark reddish yellow silty clay.		
205	Layer			0.26	Alluvial Layer. Dark brownish grey clayey silt.		
206	Layer			0.08	Alluvial Layer. Dark greyish brown peat or buried soil.		
207	Layer			0.1	Alluvial Layer. Mottled grey and reddish yellow silty clay.		
208	Layer			0.1	Alluvial Layer. Light grey silty clay.		
209	Layer			0.2	Alluvial Layer. Mid brownish grey silty clay.		
210	Layer			0.1	Alluvial Layer. Light greyish brown silty clay. Leached horizon.		
211	Layer			0.6	Alluvial Layer. Mid bluish grey clayey silt.		
212	Layer			0.6	Natural. Bluish grey mottled light olive silty clay.		
213	Layer			0.3	Natural. Light bluish grey silty clay mottled olive yellow, lenses of gravelly sand.		

Trench 3

General description				Orientation		N-S	
Trench devoid of archaeology. Consists of ploughsoil overlying alluvium deposit. This seals a stabilisation horizon. Underlying this a sequence of four alluvial deposits varying in organic Content. A leached horizon on the southern end visible. With the northern end showing a palaeochannel fill sequence. Northern end of trench augered to 3m to find base of palaeochannel around 2.8m				Length (m)		30	
				Width (m)		6	
				Avg. depth (m)		1.55	

Context No.	Type	Fill Of	Width (m)	Depth (m)	Description	Finds	Date
300	Layer			0.18	Ploughsoil. Dark grey brown, silty clay.		
301	Layer			0.17	Alluvial Layer. Mid yellowish brown mottled by mid grey. Silty clay.		
302	Layer			0.02	Other Layer. Stabilisation horizon. Dark blackish brown silty clay.		
303	Layer			0.1	Alluvial Layer. Mid greyish brown mottled by mid yellowish brown. Silty clay.		
304	Layer			0.2	Alluvial Layer. Organic alluvium. Dark greyish brown banded with black sediment. Compressed silt.		
305	Layer			0.11	Alluvial Layer. Mid greyish brown mottled by dark greyish brown. Slightly silty clay.		
306	Layer			0.12	Alluvial Layer. Pale greyish clayey silt.		
307	Layer			0.1	Other Layer. Leached horizon. Light yellowish brown slightly clayey silt.		
308	Layer			0.1	Alluvial Layer. Mid reddish brown mottled with light yellowish brown. Silty clay.		

309	Layer			0.28	Natural. Weathered bedrock. Mid yellowish brown mottled by pale greyish brown. Silty clay.		
310	Layer				Natural. Bedrock. Mid reddish brown changing to olive brown lower in context, with mid bluish grey vein mottling. Clayey silt.		
311	Layer			0.27	Alluvial Layer. Mid reddish brown silty clay.		
312	Layer			0.12	Alluvial Layer. Mid greyish brown, silty clay.		
313	Layer			0.28	Alluvial Layer. Darker mid greyish brown with dark brown/black humic/slightly organic clouding. Mostly at upper boundary. Silty clay.		
314	Layer			0.26	Alluvial Layer. Pale greyish brown mottled by a mid-bluish grey.		
315	Layer			0.13	Alluvial Layer. Mid bluish grey, waterlogged clay.		
316	Layer			0.15	Alluvial Layer. Palaeochannel fill. Soft bluish grey to light bluish grey silty clay.		
317	Layer			0.48	Alluvial Layer. Palaeochannel fill. Soft grey to brownish grey, clayey silt.		
318	Layer			0.22	Alluvial Layer. Channel fill. Oft dark greenish grey slightly sandy clay.		
319	Layer			0.1	Alluvial Layer. Palaeochannel fill. Dark grey slightly sandy silty clay.		
320	Layer			0.2	Alluvial Layer. Olive mottling bedrock. Clayey silt.		

Trench 4

General description					Orientation	E-W	
Trench devoid of archaeology. East end consists of ploughsoil overlying three alluvial layers on top of a brickearth. Followed by a leached horizon and a further two brickearth type deposits before reaching weathered and natural bedrock. Western end of trench consists of ploughsoil overlying usual alluvium sequence of one context onto of stabilisation horizon. This is followed by usual varying organic alluvial sequence. This section consisted of six alluvial layers. Underlying this weathered and natural bedrock contexts. This trench shows the sloping of terrestrial land surface into the waterlogged area. Excavated to a total depth of 2m.					Length (m)	30	
					Width (m)	6	
					Avg. depth (m)	1.33	
Context No.	Type	Fill Of	Width (m)	Depth (m)	Description	Finds	Date
400	Layer			0.16	Ploughsoil. Dark greyish brown silty clay.		
401	Layer			0.28	Alluvial Layer. Pale greyish brown mottled by a light yellowish brown. Silty clay.		
402	Layer			0.03	Other Layer. Stabilisation horizon. Dark brownish black, clayey silt.		
403	Layer			0.13	Alluvial Layer. Dark greyish brown silty clay mottled by mid yellowish brown/dark greyish brown.		
404	Layer			0.1	Alluvial Layer. Organic alluvium. Banded dark greyish brown and black. With black band 0.02m thick in centre of context. Compressed silt.		

405	Layer			0.04	Alluvial Layer. Humic alluvium. Mid grey silty clay.		
406	Layer			0.3	Alluvial Layer. Mid greyish brown mottled with dark greyish brown. Silty clay.		
407	Layer			0.15	Alluvial Layer. Light greyish brown silty clay.		
408	Layer			0.14	Alluvial Layer. Dark greyish brown mottled by mid greyish brown clayey silt.		
409	Layer			0.3	Natural. Weathered bedrock. Dark greyish brown mottled by mid bluish grey. Silty clay.		
410	Layer			0.23	Natural. Mid bluish grey, clay.		
411	Layer			0.04	Alluvial Layer. Mid yellowish brown mottled by dark greyish brown, slightly silty clay. Could be same as 403.		
412	Layer			0.09	Alluvial Layer. Pale greyish brown mottled by mid yellowish brown. Silty clay.		
413	Layer			0.14	Other Layer. Brickearth type. Pale grey mottled with light yellowish brown, clay (possibly very slightly silty).		
414	Layer			0.1	Other Layer. Leached horizon. Pale grey mottled with pale yellowish brown, slightly clayey silt.		
415	Layer			0.26	Other Layer. Brickearth type deposit. Mid reddish brown mottled by pale grey.		
416	Layer			0.35	Other Layer. Brickearth type. Dark reddish brown mottled by mid grey. Very slightly silty clay.		
417	Layer			0.15	Natural. Weathered bedrock. Mid reddish brown mottled by manganese specks. Clayey silt.		
418	Layer			0.3	Natural. Dark reddish brown silty clay, slight mottling of mid grey mottling in areas.		

Trench 5

General description					Orientation		ESE-WNW
Trench devoid of archaeology. Consists of ploughsoil overlying a sequence of alluvium and peat deposits with a weathered bedrock and London clay base. Excavated to a max depth of 2m. Sondage excavated at E. end of trench to 2.5m.					Length (m)		30
					Width (m)		6
					Avg. depth (m)		1.42
Context No.	Type	Fill Of	Width (m)	Depth (m)	Description	Finds	Date
500	Layer			0.2	Ploughsoil. Dark greyish brown, clayey silt.		
501	Layer			0.28	Alluvial Layer. Firm mid yellowish brown, clayey silt		
502	Layer			0.04	Other Layer. Stabilization layer. Firm mid reddish brown silty clay. With channels of oxidized Fe.		
503	Layer			0.06	Alluvial Layer. Firm mid yellowish brown clay silt with mid grey and fe mottle.		

504	Layer			0.06	Other Layer. Firm mid reddish brown silty clay with common oxidation.		
505	Layer		0.16		Alluvial Layer. Firm brownish grey silty clay mottled with reddish yellow fe oxidation.		
506	Layer			0.1	Alluvial Layer. Soft pale reddish grey sandy flayed silt mottled with Fe oxidation.		
507	Layer			0.14	Alluvial Layer. Soft mid reddish yellow sandy clayed silt fe oxidation throughout.		
508	Layer			0.4	Natural. Weathered bedrock. Soft dark grey silty clay with fe channels.		
509	Layer			0.1	Natural. Soft dark bluish grey silty clay with mid brown veins Bedrock.		
510	Layer			0.14	Alluvial Layer. Firm slightly grey brown silty clay with oxidising.		
511	Layer			0.04	Buried soil. Friable dark reddish brown organic rich slightly clayey silt.		
512	Layer			0.02	Buried soil. Friable very dark brown slightly clayey silt. Organic rich. Peat.		
513	Layer			0.04	Other Layer. Friable dark reddish brown organic rich silt. Peat.		
514	Layer			0.06	Alluvial Layer. Soft dark reddish brown silty clay.		

Trench 6

General description		Orientation	N-S
Trench revealed an unurned cremation. Consists of ploughsoil and subsoil overlying alluvial layers and silty clay natural. Excavated to a max depth of 2m.		Length (m)	30
		Width (m)	6
		Avg. depth (m)	0.82

Context No.	Type	Fill Of	Width (m)	Depth (m)	Description	Finds	Date
600	Layer			0.26	Ploughsoil. Dark greyish brown, clayey silt.		
601	Layer			0.2	Alluvial Layer. Dark brownish yellow mottled grey and yellow silty clay.		
602	Layer			0.16	Alluvial Layer. Brownish yellow silty clay.		
603	Layer			0.15	Alluvial Layer. Light brown mottled strong brown silty clay.		
604	Layer			0.1	Natural. Light grey silt. Leached horizon.		
605	Cut		0.55	0.12	Cremation Cut		
606	Fill	605	0.55	0.12	Cremation Deposit. Charcoal rich grey black silty sand. Some burnt bone present.		
607	Layer			0.24	Natural. Light yellowish brown silty clay. Weathered bedrock.		
608	Layer			0.35	Natural. Firm to stiff greyish red silty clay with bluish grey mottling. Bedrock.		
609	Layer			0.07	Natural. Brownish yellow silty clay. Hydromorphic horizon.		
610	Layer			0.15	Natural. Yellowish brown clayey silt with grey veins. LCF.		
611	Layer			0.33	Natural. Dark reddish brown clayey silt. Bedrock.		

Trench 7							
General description					Orientation		NW-SE
Trench devoid of archaeology. Consists of ploughsoil overlying alluvial layers, peat and leached horizon deposits. Palaeochannel at the SE end. Excavated to a max depth of 2m.					Length (m)		50
					Width (m)		6
					Avg. depth (m)		0.93
Context No.	Type	Fill Of	Width (m)	Depth (m)	Description	Finds	Date
700	Layer			0.22	Ploughsoil. Dark greyish brown, clayey silt.		
701	Layer			0.04	Alluvial Layer. Dark brown clayey silt.		
702	Layer			0.04	Other Layer. Dark blackish brown slightly clayey silt. Peaty. Organic rich silt?		
703	Layer			0.12	Alluvial Layer. Mid brown with mid greyish brown mottling clayey silt.		
704	Layer			0.12	Alluvial Layer. Dark grey with mid yellowish brown mottling clayey silt.		
705	Layer			0.2	Other Layer. Dark brown slightly clayey silt. Peaty. Organic rich silt?		
706	Layer			0.12	Alluvial Layer. Mid grey with mid reddish brown mottling silt.		
707	Layer			0.07	Other Layer. Light/pale grey silt. Leached horizon.		
708	Layer			0.35	Natural. Mid reddish brown clayey silt. Head deposit.		
709	Layer			0.16	Natural. Dark reddish brown with mid grey mottling clayey silt. Head deposit.		
710	Layer			0.16	Natural. Mid brown with mid blueish grey mottling clayey silt. Weathered bedrock? Head deposit?		
711	Layer			0.14	Natural. Mod greyish brown clayey silt. Weathered bedrock.		
712	Layer				Natural. Mid brown with mid blueish grey mottling sandy silt. Weathered bedrock.		
713	Layer			0.12	Other Layer. Dark olive grey with mottled dark grey silty clay. Channel fill/alluvium.		
714	Layer			0.12	Other Layer. Mid brown clayey silt. Channel fill/ alluvium.		
715	Layer			0.15	Other Layer. Mid olive grey clayey silt. Channel fill/alluvium.		
716	Layer			0.15	Other Layer. Mid grey silty clay. Channel fill/alluvium.		
717	Layer			0.2	Other Layer. Mid greenish grey clayey silt. Channel fill/ alluvium.		
718	Layer			0.15	Other Layer. Mid greenish grey silty clay. Channel fill.		
719	Layer			0.07	Other Layer. Mid greenish grey silty clay. Channel fill/alluvium.		
720	Layer				Natural. Light grey clayey silt. Weathered bedrock/bedrock.		
Trench 8							
General description					Orientation		NW-SE

Trench devoid of archaeology. Consists of ploughsoil and made ground covering a deep sequence of alluvial layers and a possible organic buried soil. Excavated to a total depth of 2m.						Length (m)		30
						Width (m)		6
						Avg. depth (m)		1.63
Context No.	Type	Fill Of	Width (m)	Depth (m)	Description	Finds	Date	
800	Layer			0.28	Ploughsoil. Dark greyish brown clayey silt.			
801	Layer			0.96	Alluvial Layer. Mid reddish brown clayey silt with frequent patches of light grey sandy silt and frequent patches of mid greyish brown clayey silt.			
802	Layer			0.16	Alluvial Layer. Mid reddish brown clayey silt with frequent mid yellowish brown mottling.			
803	Layer			0.05	Buried soil. Dark greyish brown humic clayey silt.			
804	Layer			0.07	Buried soil. Mid reddish brown clayey silt with frequent mid yellowish brown mottling.			
805	Layer			0.15	Alluvial Layer. Dark greyish brown humic clayey silt with mid greyish brown and light greyish brown striations every 0.01m.			
806	Layer			0.14	Alluvial Layer. Mid brownish grey clayey silt.			
807	Layer			0.1	Alluvial Layer. Light grey sandy silt.			
808	Layer				Natural. Light brownish grey clay with patches of light grey silty clay. Weathered London Clay.			

Trench 9

General description						Orientation		NW-SE
Trench devoid of archaeology. Trench consists of ploughsoil overlying a sequence of alluvial layers and buried soils over weathered bedrock. Excavated to a max depth of 2m.						Length (m)		30
						Width (m)		6
						Avg. depth (m)		1.18
Context No.	Type	Fill Of	Width (m)	Depth (m)	Description	Finds	Date	
900	Layer			0.25	Ploughsoil. Dark greyish brown clayey silt.			
901	Layer			0.23	Alluvial Layer. Mid brownish grey clayey silt with very frequent yellowish brown mottling.			
902	Layer			0.05	Buried soil. Dark greyish brown humic clayey silt.			
903	Layer			0.09	Alluvial Layer. Dark reddish brown clayey silt with frequent mid yellowish brown mottling.			
904	Layer			0.15	Buried soil. Dark greyish brown humic clayey silt with mid greyish brown clayey silt layers.			
905	Layer			0.11	Alluvial Layer. Mid greyish brown clayey silt.			
906	Layer			0.3	Alluvial Layer. Light grey sandy silt.			
907	Layer			0.36	Natural. Light reddish brown clay with frequent mid grey mottling. Weathered London Clay.			

908	Layer			0.28	Natural. Mid reddish brown clay with frequent mid grey mottling. Weathered London Clay.		
909	Layer				Natural. Mid brown clay with mid grey mottling and light brown striations every 0.02m. London Clay.		

Trench 10

General description					Orientation		NW-SE
Trench devoid of archaeology. Consists of ploughsoil overlying alluvium, leached horizon, head deposit and weathered bedrock. Excavated to a max depth of 2m.					Length (m)		30
					Width (m)		6
					Avg. depth (m)		1.26
Context No.	Type	Fill Of	Width (m)	Depth (m)	Description	Finds	Date
1000	Layer			0.25	Ploughsoil. Dark grey clayey silt.		
1001	Layer			0.21	Alluvial Layer. Mid grey clayey silt.		
1002	Layer			0.08	Other Layer. Dark blackish brown slightly clayey silt. Organic rich silt?		
1003	Layer			0.09	Alluvial Layer. Dark grey clayey silt.		
1004	Layer			0.2	Other Layer. Dark purplish brown silt with trace of clay. Organic rich silt? Peaty?		
1005	Layer			0.11	Alluvial Layer. Mid grey clayey silt.		
1006	Layer			0.14	Alluvial Layer. Mid grey slightly clayey silt.		
1007	Layer			0.14	Other Layer. Light-pale grey silt with sand patches. Leached horizon?		
1008	Layer			0.31	Other Layer. Mid reddish brown clayey silt. Head deposit?		
1009	Layer			0.94	Natural. Mid brown clayey silt. Weathered bedrock.		
1010	Layer				Natural. Mid brown clayey silt with sandy silt lenses and pebble lenses. Weathered bedrock.		

Trench 11

General description					Orientation		NW-SE
Trench devoid of archaeology. Consists of ploughsoil with an alluvium and stabilisation horizon. This is then followed by series of organic rich alluvium sand a banded peat layer. The base consists of weathered bedrock. Excavated to a max depth of 2m.					Length (m)		30
					Width (m)		6
					Avg. depth (m)		1.37
Context No.	Type	Fill Of	Width (m)	Depth (m)	Description	Finds	Date
1100	Layer			0.24	Ploughsoil. Dark greyish brown, clayey silt.		
1101	Layer			0.22	Alluvial Layer. Firm mid yellowish brown silty clay.		
1102	Layer			0.02	Buried soil. Friable very dark brown clayey silt. Stabilisation horizon.		
1103	Layer			0.12	Alluvial Layer. Friable mid reddish brown clayey silt.		
1104	Layer			0.14	Other Layer. Dark reddish brown silty peat.		
1105	Layer			0.2	Alluvial Layer. Soft strong brown clayey silt. Organic rich		

1106	Layer			0.26	Alluvial Layer. Soft mid greyish brown clayey silt with organic material		
1107	Layer			0.1	Alluvial Layer. Soft dark grey silty clay with common charcoal content.		
1108	Layer			0.45	Natural. Soft to friable mid reddish brown silty clay. Weathered bedrock		

Trench 12

General description					Orientation		NNW-SSE
Trench devoid of archaeology. Consists of ploughsoil overlying alluvial layers and a buried soil.					Length (m)		30
					Width (m)		6
					Avg. depth (m)		2

Context No.	Type	Fill Of	Width (m)	Depth (m)	Description	Finds	Date
1200	Layer			0.22	Ploughsoil. Dark greyish brown clayey silt with frequent patches of yellowish brown clayey silt.		
1201	Layer			0.28	Alluvial Layer. Mid yellowish brown clayey silt with frequent patches of mid grey clayey silt.		
1202	Layer			0.04	Buried soil. Dark greyish brown humic clayey silt.		
1203	Layer			0.17	Alluvial Layer. Dark reddish brown clayey silt.		
1204	Layer			0.16	Alluvial Layer. Dark reddish brown clayey silt with bands of mid greyish brown clayey silt.		
1205	Layer			0.28	Buried soil. Mid greyish brown clayey silt with infrequent patches of light brownish grey clayey silt.		
1206	Layer			0.69	Alluvial Layer. Mid greenish grey clayey silt with light yellowish brown mottling.		
1207	Layer				Alluvial Layer. Mid greyish brown with frequent reddish brown mottling.		
1208	Layer			0.29	Alluvial Layer. Mid brownish grey clayey silt with infrequent mid brown mottling.		
1209	Layer			0.13	Alluvial Layer. Mid bluish grey silty clay with very frequent organic material.		
1210	Layer			0.15	Alluvial Layer. Mid bluish grey silty clay with infrequent organic material.		

Trench 13

General description					Orientation		NE-SW
Trench revealed one posthole. Consists of ploughsoil overlying alluvial deposits, possible leached horizon, alluvial deposit and possible weathered bedrock. Excavated to a max depth of 2m.					Length (m)		30
					Width (m)		6
					Avg. depth (m)		1.78

Context No.	Type	Fill Of	Width (m)	Depth (m)	Description	Finds	Date
1300	Layer			0.36	Ploughsoil. Dark blackish grey clayey silt.		
1301	Layer			0.15	Alluvial Layer. Mid blueish grey clayey silt.		

1302	Layer			0.15	Alluvial Layer. Dark greyish brown silty clay.		
1303	Layer			0.09	Alluvial Layer. Mottled mid grey. Mid reddish brown mottling. Silty clay.		
1304	Layer			0.05	Other Layer. Dark blackish grey slightly clayey silt. Organic rich silt?		
1305	Layer			0.02	Alluvial Layer. Mid grey clayey silt		
1306	Layer			0.18	Alluvial Layer. Mid brown slightly clayey silt.		
1307	Layer			0.33	Alluvial Layer. Dark brownish grey slightly clayey silt.		
1308	Layer			0.06	Other Layer. Light grey slightly sandy, clayey silt. Leached horizon?		
1309	Layer			0.54	Alluvial Layer. Light blueish grey clayey silt.		
1310	Layer			0.63	Other Layer. Mid brown with mid blueish grey mottling. Silty clay. Weathered bedrock?		
1311	Cut		0.3	0.18	Posthole		
1312	Fill	1311	0.3	0.18	Primary Fill. Dark brown black. Abundant charcoal. Sample 143. S.1302		
1313	Layer			0.6	Natural. Mid olive brown slightly silty, sandy clay. Bedrock? LCF.		

Trench 14

General description						Orientation	N-S
Trench revealed an alignment of six posts, preserved in situ in the alluvial deposits. Possibly relating to a crossing point or trackway. Consists of ploughsoil overlying a sequence of alluvial deposits over London clay bedrock. Excavated to a max depth of 2m. Sondage excavated to 3m at N end.						Length (m)	30
						Width (m)	6
						Avg. depth (m)	1.88
Context No.	Type	Fill Of	Width (m)	Depth (m)	Description	Finds	Date
1400	Layer			0.28	Ploughsoil. Dark greyish brown, clayey silt.	Flint	
1401	Cut	1401			Posthole		
1402	Fill	1401			Wooden Object		
1403	Cut	1403			Posthole		
1404	Fill	1403			Wooden Object		
1405	Cut	1405			Posthole		
1406	Fill	1405			Wooden Object		
1407	Cut	1407			Posthole		
1408	Fill	1407			Wooden Object		
1409	Cut		0.08	0.76	Posthole		
1410	Fill	1409			Wooden Object		
1411	Layer			0.12	Alluvial Layer. Mid yellowish brown, clayey silt.		
1412	Layer			0.14	Other Layer. Blackish brown, humic clayey silt.		
1413	Layer			0.22	Alluvial Layer. Light brownish grey, silty clay.		
1414	Layer			0.06	Alluvial Layer. Blackish brown, organic rich silty clay.		

1415	Layer			0.1	Alluvial Layer. Mid grey silty clay with frequent rooting.		
1416	Layer			0.22	Alluvial Layer. Mid greyish brown clay with occasional organic matter.	Flint	
1417	Layer			0.22	Alluvial Layer. Mid olive brown, silty clay.		
1418	Layer			0.22	Natural. Mid greyish blue clay. London clay bedrock.		
1419	Cut		0.44	0.16	Natural Gully		
1420	Fill	1419	0.44	0.16	Secondary Fill. Blackish brown, clayey humic silt.		
1421	Cut		0.07	1.12	Posthole		
1422	Fill	1421	0.07	1.12	Wooden Object		
1423	Layer			0.13	Alluvial Layer. Mid brown silty clay.		
1424	Layer			0.24	Alluvial Layer. Light yellowish brown, clayey silt.		
1425	Layer			0.22	Alluvial Layer. Mid greyish blue, silty clay.		
1426	Layer			0.11	Alluvial Layer. Light brown grey, clayey silt. Frequent brownish red mottling. Root channels. Rare charcoal.		
1427	Structure				Other Structure. Crossing point/ trackway. Comprises six wooden posts (1402)(1404)(1406)(1408)(1410)(1422).		
1428	Layer			0.04	Natural. Mid greyish brown, silty clay with abundant gravel.		
1429	Layer			0.24	Natural. Mid greyish brown silty clay with silt mid brown silt veins.		
1430	Layer				Natural. Mid greyish brown clay. Bedrock.		
1431	Layer				Alluvial Layer. Dark olive brown clayey silt.		
1432	Layer			200	Alluvial Layer. Mid greyish brown silty clay.		
1433	Layer			0.12	Alluvial Layer. Dark greyish brown silty clay with organic material.		
1434	Layer			0.14	Alluvial Layer. Olive grey silty clay with organic matter.		
1435	Layer			0.48	Alluvial Layer. Dark olive grey sandy clay, humic and organic.		
1436	Layer			0.32	Natural. Mid greyish brown silty clay.		

Trench 15

General description					Orientation		NW-SE
Trench devoid of archaeology. Consists of ploughsoil overlying an alluvium sealing a stabilisation horizon. Below this another alluvium overlying a buried soil. Then complex sequence of slightly organic and charcoal rich alluviums in section 1501. With (1509) omitted from s# 1500 and replaced by a slightly organic context. Below this weathered bedrock and bedrock visible in 1501. Stepped trench excavated to depth of 2m, with 2x4m pit to 3m BGL 3m from NW end.					Length (m)		30
					Width (m)		6
					Avg. depth (m)		1.74
Context No.	Type	Fill Of	Width (m)	Depth (m)	Description	Finds	Date
1500	Layer			0.33	Ploughsoil. Mid greyish brown silty clay.		

1501	Layer			0.19	Alluvial Layer. Mid yellowish/reddish brown mottled by pale grey slightly silty clay.		
1502	Layer			0.02	Other Layer. Stabilisation horizon. Dark black organic slightly peaty silt.		
1503	Layer			0.18	Alluvial Layer. Mid greyish brown mottled by a mid-yellowish brown, silty clay.		
1504	Layer			0.19	Buried soil. Strong brown mottled with mid greyish brown silty peat/soil.		
1505	Layer			0.04	Alluvial Layer. Mid greyish brown slightly silty clay.		
1506	Layer			0.18	Alluvial Layer. Organic alluvium. Pale greyish brown mottled with dark brown plants remains. Slight peaty silt.		
1507	Layer			0.2	Alluvial Layer. Pale yellowish brown mottled with mid reddish brown oxidised worming channel infill.		
1508	Layer			0.13	Alluvial Layer. Pale bluish grey, slightly silty clay.		
1509	Layer			0.12	Alluvial Layer. Mid bluish grey mottled by manganese/ charcoal smudges and specks. Silty clay.		
1510	Layer			0.17	Natural. Weathered bedrock. Mid grey mottled by mid yellowish brown, slightly city clay.		
1511	Layer			0.14	Natural. Mid bluish grey mottled by mid yellowish brown very slightly silty clay.		
1512	Layer			0.34	Alluvial Layer. Soft dark olive silty clay with organic material.		
1513	Layer			0.4	Natural. Bluish grey mottled olive yellow silty clay. In 3m deep test pit.		
1514	Layer			0.4	Natural. Firm bluish grey mottled olive and white with yellow silt lenses. LONDON CLAY FORMATION.		

Trench 16

General description					Orientation		WNW-ESE
Trench devoid of archaeology. Consisting of ploughsoil, Alluvium with layers of peat, weather bedrock with black rooting, Geological ground reached at depth of 1.46. Palaeo channel [1613] present at W end.					Length (m)		30
					Width (m)		6
					Avg. depth (m)		1.46
Context No.	Type	Fill Of	Width (m)	Depth (m)	Description	Finds	Date
1600	Layer			0.23	Ploughsoil. Dark greyish brown clayey silt with frequent yellowish brown mottling.		
1601	Layer			0.25	Alluvial Layer. Yellowish brown clayey silt with frequent light grey mottling, infrequent dark greyish brown veins.		
1602	Layer			0.03	Buried soil. Very dark greyish brown humic clayey silt.		
1603	Layer			0.07	Alluvial Layer. Yellowish grey clayey silt with frequent greyish brown mottling.		
1604	Layer			0.18	Alluvial Layer. Dark brown humic clayey silt with infrequent grey mottling.		

1605	Layer			0.07	Buried soil. Light brownish greyish clayey silt with bands of greyish brown.		
1606	Layer			0.07	Alluvial Layer. Brownish grey clayey silt with dark brownish grey mottling.		
1607	Layer			0.24	Alluvial Layer. Light brownish grey clayey silt with frequent light grey mottling.		
1608	Layer			0.39	Alluvial Layer. Light greyish brown clayey silt with frequent light grey mottling. Channel fill?		
1609	Layer			0.16	Alluvial Layer. Light bluish grey clayey silt with light grey mottling. Channel fill.		
1610	Fill	1610		0.21	Secondary Fill. Dark bluish grey clayey silt with infrequent dark brownish grey mottling.		
1611	Fill	1611		0.05	Secondary Fill. Bluish grey clayey silt with frequent light bluish grey and light yellowish brown.		
1612	Layer				Natural. Yellowish brown clayey silt with bluish grey mottling. Bedrock.		
1613	Cut				Palaeochannel		
1614	Layer			0.04	Alluvial Layer. Light greyish brown humous silt.		
1615	Layer			0.05	Alluvial Layer. Dark brown organic silt. PEAT.		
1616	Layer			0.12	Other Layer. Firm grey silty clay with black decayed rooting. WEATHERED BEDROCK / LONDON CLAY FORMATION.		

Trench 17

General description					Orientation	NW-SE	
Trench devoid of archaeology. Consists of ploughsoil overlying a sequence of buried soils/stabilisation events and alluvial deposits. Excavated to a max depth of 2m.					Length (m)	30	
					Width (m)	6	
					Avg. depth (m)	1.17	
Context No.	Type	Fill Of	Width (m)	Depth (m)	Description	Finds	Date
1700	Layer			0.26	Ploughsoil. Dark greyish brown clayey silt.		
1701	Layer			0.16	Alluvial Layer. Mid yellowish grey clayey silt with patches of mid grey clayey silt.		
1702	Layer			0.06	Buried soil. Dark greyish brown humic clayey silt.		
1703	Layer			0.1	Alluvial Layer. Mid greyish brown clayey silt with frequent mid yellowish grey mottling.		
1704	Layer			0.21	Alluvial Layer. Dark greyish brown clayey silt with bands of mid brownish grey.		
1705	Layer			0.13	Alluvial Layer. Dark greyish brown clayey silt with mid grey mottling.		
1706	Layer			0.25	Alluvial Layer. Mid greyish brown clay silt.		
1707	Layer			0.16	Alluvial Layer. Mid bluish grey clayey silt with very frequent organic flecks.		

1708	Layer			0.09	Alluvial Layer. Mid bluish grey clayey silt with very frequent yellowish brown mottling.		
1709	Layer			0.08	Alluvial Layer. Mid bluish grey clay silt with frequent reddish brown mottling.		
1710	Layer			0.22	Alluvial Layer. Mid bluish grey clayey silt with very frequent yellowish brown mottling.		
1711	Layer				Natural. Blueish grey mottled with yellowish brown (20%). Silty clay. Bedrock.		

Trench 18

General description					Orientation		N-S
Trench devoid of archaeology. Consists of ploughsoil, mineral and organic alluvium, leached horizon and London clay. Excavated to a max depth of 2m at NNW end.					Length (m)		30
					Width (m)		6
					Avg. depth (m)		0.79
Context No.	Type	Fill Of	Width (m)	Depth (m)	Description	Finds	Date
1800	Layer			0.25	Ploughsoil. Dark black, silty clay.		
1801	Layer			0.16	Alluvial Layer. Brownish yellow silty clay.		
1802	Layer			0.04	Alluvial Layer. Grey mottled black silty clay.		
1803	Layer			0.3	Alluvial Layer. Greyish brown silty clay.		
1804	Layer			0.11	Alluvial Layer. Dark brown humic rich clay.		
1805	Layer			0.08	Other Layer. Light brownish grey silt. LEACHED HORIZON.		
1806	Layer			0.11	Natural. Grey mottled brownish yellow. WEATHERED BEDROCK.		
1807	Layer			0.16	Natural. Yellowish brown fissured clayey silt. WEATHERED BEDROCK.		

Trench 19

General description					Orientation		NE-SW
Trench revealed one pit. Trench consists of ploughsoil overlying alluvium, stabilisation horizon, leached horizon, head deposit and weathered bedrock. Excavated to a total depth of 1.44m at NE end.					Length (m)		30
					Width (m)		6
					Avg. depth (m)		1.16
Context No.	Type	Fill Of	Width (m)	Depth (m)	Description	Finds	Date
1900	Layer			0.24	Ploughsoil. Dark greyish brown clayey silt.	Flint	
1901	Layer			0.17	Alluvial Layer. Mid grey with light yellowish brown mottling. Clayey silt.		
1902	Layer			0.26	Alluvial Layer. Mid grey with mid yellowish brown mottling. Slightly clayey silt.		
1903	Layer			0.11	Other Layer. Light grey with mid reddish brown mottling. Slightly clayey sandy silt. Leached horizon.		
1904	Cut		1.04	0.38	Pit		
1905	Fill	1904	1.04	0.38	Primary Fill. Soft, dark greyish brown, silty clay.		

1906	Layer			0.09	Natural. Mid reddish brown sandy silt. Head deposit.		
1907	Layer			0.08	Other Layer. Dark greyish brown silt. Stabilisation horizon?/humic rich silt?.		
1908	Layer			0.07	Other Layer. Mid greyish brown silt. Stabilisation horizon?/humic rich silt?.		
1909	Layer			0.13	Alluvial Layer. Mid grey silty clay.		
1910	Layer			0.1	Alluvial Layer. Mid grey with yellowish brown mottling. Slightly clayey silt.		
1911	Layer				Natural. Dark reddish brown silty clay. Weathered bedrock.		
1912	Unexcavated feature				Natural Feature		

Trench 20

General description					Orientation		NW-SE
Trench consists of ploughsoil overlying two alluvial contexts sealing a leached horizon (containing flints). In NW end of the trench a further two brick earth type deposits underlying this sequence which end in the centre of the trench. Below this a brick earth deposit that spans the length of the trench, overlying a weathered bedrock and head deposit in the NW and natural bedrock in the SE end. Excavated to a max depth of 2m.					Length (m)		30
					Width (m)		6
					Avg. depth (m)		0.42
Context No.	Type	Fill Of	Width (m)	Depth (m)	Description	Finds	Date
2000	Layer			0.24	Ploughsoil. Dark greyish brown silty clay.		
2001	Layer			0.12	Alluvial Layer. Mid yellowish brown mottled by dark greyish brown. Silty clay.		
2002	Layer			0.16	Alluvial Layer. Mid grey mottled by a mid-yellowish brown. Silty clay.	Flint	
2003	Layer			0.13	Other Layer. Leached Horizon. Pale grey mottled by mid yellowish brown slightly clayey silt.		
2004	Layer			0.12	Other Layer. Brickearth type deposit. Mid reddish brown, mottled by mid grey slightly silty clay.		
2005	Layer			0.19	Other Layer. Brickearth type. Pale reddish brown silty clay.		
2006	Layer			0.2	Other Layer. Brickearth type. Mid reddish brown silty clay, some mid grey mottling in northern end of trench.		
2007	Layer			0.2	Natural. Weathered bedrock? Dark reddish brown mottled by calcific sediment. Clayey silt.		
2008	Layer			0.18	Other Layer. Head deposit. Strong brown silty sand. Abundant subangular pebbles.		
2009	Layer			0.39	Natural. Bedrock. Mid reddish brown mottled by mid bluish grey veins. Slightly silty clay.		

Trench 21

General description					Orientation		ENE-WSW
					Length (m)		30
					Width (m)		2

Trench devoid of archaeology. Consists of ploughsoil and subsoil overlying a leached horizon deposit over a sandy clay natural head. Excavated to a max depth of 1m.					Avg. depth (m)	0.61	
Context No.	Type	Fill Of	Width (m)	Depth (m)	Description	Finds	Date
2100	Layer			0.26	Ploughsoil. Dark greyish brown clayey silt.		
2101	Layer			0.14	Subsoil. Mid greyish brown silty clay.		
2102	Layer			0.21	Other Layer. Light bluish grey silty clay.		
2103	Layer				Natural. Mottled blue and yellowish brown sandy clay.		
2104	Void						

Trench 22

General description					Orientation	N-S	
Trench devoid of archaeological features. Trench consists of ploughsoil overlying alluvial and buried peat layers over a sequence of weathered bedrock. Worked flint found within buried soil deposit. Excavated to a max depth of 2m.					Length (m)	30	
					Width (m)	6	
					Avg. depth (m)	0.84	
Context No.	Type	Fill Of	Width (m)	Depth (m)	Description	Finds	Date
2200	Layer			0.28	Ploughsoil. Dark greyish brown clayey silt with infrequent yellowish brown mottling.		
2201	Layer			0.06	Buried soil. Very dark greyish brown humic clayey silt with rare yellowish brown mottling.		
2202	Layer			0.04	Alluvial Layer. Yellowish brown clayey silt with very frequent grey mottling.	Pot, Flint	E. Neo or MBA-MIA
2203	Layer			0.16	Buried soil. Very dark greyish brown humic clayey silt with rare yellowish brown mottling. Flint and pot recovered from this layer.	Flint	
2204	Layer			0.11	Alluvial Layer. Yellowish brown clayey silt with frequent grey mottling and frequent dark greyish brown veins.		
2205	Layer			0.05	Buried soil. Very dark greyish brown humic clayey silt with infrequent yellowish brown mottling.		
2206	Layer			0.11	Alluvial Layer. Light greyish brown clayey silt with frequent yellowish brown mottling and dark greyish brown veins.		
2207	Layer			0.1	Alluvial Layer. Light grey sandy silt frequent yellowish brown mottling and frequent brown mottling.		
2208	Layer			0.48	Natural. Light reddish brown clayey silt with light grey mottling and light grey veins. Weathered bedrock.		
2209	Layer			0.5	Natural. Greyish brown clay with frequent grey mottling and grey veins. Weathered bedrock.		
2210	Layer				Natural. Brownish grey clay with infrequent greyish brown mottling.		

Trench 23

General description						Orientation		ESE-WNW
Trench devoid of archaeology. Consists of ploughsoil and subsoil overlying a natural head deposit.						Length (m)		30
						Width (m)		2
						Avg. depth (m)		0.44
Context No.	Type	Fill Of	Width (m)	Depth (m)	Description	Finds	Date	
2300	Layer			0.36	Ploughsoil. Dark greyish brown clayey silt.			
2301	Layer			0.08	Subsoil. Mid greyish brown silty clay.			
2302	Layer				Natural. Mid reddish brown silty clay with gravel.			

Trench 24

General description						Orientation		NW-SE
Trench devoid of archaeological features. Consists of ploughsoil and subsoil overlying a head deposit and bedrock.						Length (m)		30
						Width (m)		6
						Avg. depth (m)		0.48
Context No.	Type	Fill Of	Width (m)	Depth (m)	Description	Finds	Date	
2400	Layer			0.28	Ploughsoil. Mid greyish brown clayey silt.			
2401	Layer			0.2	Subsoil. Mid olive green clayey silt.	Flint		
2402	Layer			0.32	Natural. Mid reddish brown clayey sandy silt with gravels. Head deposit.			
2403	Layer				Natural. Mid reddish brown silty clay with blueish grey mottling and white calcium inclusions. Bedrock.			

Trench 25

General description						Orientation		N-S
Trench devoid of archaeological features. Consists of ploughsoil overlying an alluvial layer (with struck flint) and a leached horizon deposit over weathered bedrock and then LCF bedrock. Excavated to a max depth of 1.4m.						Length (m)		30
						Width (m)		6
						Avg. depth (m)		0.57
Context No.	Type	Fill Of	Width (m)	Depth (m)	Description	Finds	Date	
2500	Layer			0.3	Ploughsoil. Dark greyish brown clayey silt.			
2501	Layer			0.15	Alluvial Layer. Mid brownish grey mottled brownish yellow clayey silt. Contained some worked flints and burnt flint.	Flint		
2502	Layer			0.12	Other Layer. Light yellowish brown clayey silt. Leached Horizon.			
2503	Layer			0.18	Natural. Light brown clayey silt. Weathered bedrock.			
2504	Layer			0.34	Natural. Mid brown mottled light greyish brown silty clay. Weathered bedrock.			
2505	Layer				Natural. Mid brown mottled bluish grey clayey silt. LCF.			

Trench 26

General description						Orientation		NE-SW
---------------------	--	--	--	--	--	-------------	--	-------

Trench devoid of archaeological features. Trench consists of ploughsoil overlying alluvial deposits over a leached horizon/buried soil (with struck flint) and a head deposit.						Length (m)		30
						Width (m)		6
						Avg. depth (m)		0.61
Context No.	Type	Fill Of	Width (m)	Depth (m)	Description	Finds	Date	
2600	Layer			0.24	Ploughsoil. Dark greyish brown clayey silt with infrequent yellowish brown mottling.			
2601	Layer			0.12	Buried soil. Greyish brown sandy clayey silt with frequent yellowish brown infrequent dark greyish brown mottling. Leached horizon.	Flint		
2602	Layer				Natural. Reddish brown silty clay with frequent greyish brown mottling. Head deposit.			
2603	Cut		0.92	0.28	Natural Feature. Mid pinkish brown silty clay fill with frequent inclusions of charcoal.			
2604	Layer			0.14	Alluvial Layer. Yellowish brown clayey silt with frequent dark greyish brown mottling.			
2605	Layer			0.09	Alluvial Layer. Light yellowish brown clayey silt with frequent yellowish brown and infrequent dark greyish brown mottling.			

Trench 27

General description						Orientation		W-E
Trench devoid of archaeology. Consists of ploughsoil overlying several alluvial layers with gravel head deposits and weathered bedrock. Excavated to a max depth of 2m.						Length (m)		30
						Width (m)		5.3
						Avg. depth (m)		0.96

Context No.	Type	Fill Of	Width (m)	Depth (m)	Description	Finds	Date
2700	Layer			0.24	Ploughsoil. Dark greyish brown clayey silt.		
2701	Layer			0.1	Alluvial Layer. Mid reddish brown silty clay.		
2702	Layer			0.11	Other Layer. Mottled grey and reddish brown silty clay.		
2703	Layer			0.06	Natural. Head deposit. Mid reddish brown sandy clay with gravel.		
2704	Layer				Natural. Head deposit. Mottled blue and yellow greyish brown sandy clay with gravel.		
2705	Layer			0.06	Buried soil. Dark greyish brown silty clay, humic.		
2706	Layer				Alluvial Layer. Mid reddish brown silty clay.		
2707	Layer			0.04	Natural. Light to mid reddish brown silty gravel. Head deposit.		
2708	Layer			0.14	Alluvial Layer. Light brownish grey silty clay.		

Trench 28

General description						Orientation		E-W
---------------------	--	--	--	--	--	-------------	--	-----

Trench devoid of archaeology. Consists of ploughsoil overlying a thin grey clay layer of alluvium. This overlies an light grey leached horizon, which overlies the natural of Pleistocene Head deposit and bedrock.						Length (m)		30
						Width (m)		6
						Avg. depth (m)		0.53
Context No.	Type	Fill Of	Width (m)	Depth (m)	Description	Finds	Date	
2800	Layer			0.3	Ploughsoil. Dark greyish brown clayey silt.			
2801	Layer			0.17	Alluvial Layer. Light brownish grey silty clay.			
2802	Layer			0.11	Other Layer. Light olive grey slightly clayey silt. LEACHED HORIZON.			
2803	Layer			0.22	Natural. Yellowish brown silty clay. BRICK EARTH TYPE DEPOSIT / PLEISTOCENE			
2804	Layer			0.37	Natural. Brown gravelly clayey sand. HEAD DEPOSIT.			
2805	Layer			0.88	Natural. Brown mottled white, yellow and bluish grey clayey silt. LONDON CLAY FORMATION.			
Trench 29								
General description						Orientation		WSW-ENE
Trench devoid of archaeology. Consists of ploughsoil overlying subsoil, natural and bedrock. Trench excavated to max depth of 2m.						Length (m)		30
						Width (m)		6
						Avg. depth (m)		0.41
Context No.	Type	Fill Of	Width (m)	Depth (m)	Description	Finds	Date	
2900	Layer			0.32	Ploughsoil. Dark greyish brown clayey silt.			
2901	Layer			0.09	Subsoil. Light olive grey silty clay. LEACHED HORIZON.			
2902	Layer				Natural. Mid yellowish brown silty clay with gravel.			
2903	Layer			0.5	Natural. Brown silty clay with gravel. HEAD DEPOSIT.			
2904	Layer			0.9	Natural. Yellowish brown clayey gravel. Large intrusive lenses of above in contexts 29003 and 29005 an at east end of trench. KRYOTURBATION.			
2905	Layer			0.9	Natural. Reddish brown mottled white, yellow and bluish grey silty clay. LONDON CLAY FORMATION.			
Trench 30								
General description						Orientation		NE-SW
Trench devoid of archaeological features. Trench consists of ploughsoil overlying an alluvial layer and a leached horizon (containing struck flints) over weathered bedrock and bedrock.						Length (m)		30
						Width (m)		6
						Avg. depth (m)		0.52
Context No.	Type	Fill Of	Width (m)	Depth (m)	Description	Finds	Date	
3000	Layer			0.32	Ploughsoil. Dark greyish brown clayey silt with infrequent yellowish brown mottling.			

3001	Layer			0.12	Alluvial Layer. Yellowish brown clayey silt with frequent grey mottling and frequent dark greyish brown veins.		
3002	Layer			0.14	Other Layer. Light brownish grey sandy silty clay with frequent yellowish brown mottling and dark greyish brown veins. Leached horizon.	Flint	
3003	Layer			0.59	Natural. Light reddish brown silty clay with frequent light grey mottling. Weathered bedrock.		
3004	Layer			0.55	Natural. Light reddish brown silty clay with frequent grey mottling and frequent grey veins. Weathered bedrock.		
3005	Layer				Natural. Reddish brown clay with frequent grey mottling and frequent grey veins. Bedrock.		

Trench 31

General description		Orientation	E-W
Trench devoid of archaeology. Consists of ploughsoil overlying a sequence of alluvium often humic rich. They rest upon a brick earth then weathered bedrock and bedrock. Sondage excavated to 2.4m at W end.		Length (m)	30
		Width (m)	6
		Avg. depth (m)	1.06

Context No.	Type	Fill Of	Width (m)	Depth (m)	Description	Finds	Date
3100	Layer			0.24	Ploughsoil. Dark greyish brown clayey silt.		
3101	Layer			0.06	Alluvial Layer. Mid greyish brown mottled with light reddish brown. Slightly silty clay		
3102	Layer			0.04	Other Layer. Stabilisation horizon Slightly Organic black silt		
3103	Layer			0.08	Alluvial Layer. Mid greyish brown mottled by a subtle strong brown and mid yellowish brown. Clayey silt		
3104	Layer			0.09	Alluvial Layer. Mid yellowish brown mottled by a mid-greyish brown. Silty clay.		
3105	Layer			0.02	Alluvial Layer. Humic alluvium/buried soil? Dark brown slightly clayey silt		
3106	Layer			0.12	Alluvial Layer. Pale greyish brown mottled by mid yellowish brown silty clay		
3107	Layer			0.15	Alluvial Layer. Pale grey mottled by mid yellowish brown. Silty clay		
3108	Layer			0.1	Alluvial Layer. Mid grey mottled by mid reddish brown. Clayey silt		
3109	Layer			0.16	Other Layer. Pale/light bluish grey mottled with mid reddish brown. Slightly clayey silt. Leached horizon		
3110	Layer			0.34	Other Layer. Pale reddish brown mottled with mid bluish grey.		
3111	Layer			0.17	Natural. Weathered bedrock Mid greyish brown mottled with mid bluish grey and mid reddish brown Slightly clayey silt		

3112	Layer			0.35	Natural. Bedrock Mid reddish brown mottled by mid bluish grey slightly silty clay.		
Trench 32							
General description					Orientation		E-W
Trench devoid of archaeology. Consists of ploughsoil overlying two alluvial layers which overlies a fluvial or head deposit which overlies an alluvial deposit and bedrock.					Length (m)		30
					Width (m)		2
					Avg. depth (m)		0.3
Context No.	Type	Fill Of	Width (m)	Depth (m)	Description	Finds	Date
3200	Layer			0.3	Ploughsoil. Mid blackish brown clayey silt.		
3201	Layer			0.14	Alluvial Layer. Mottled mid reddish brown silty clay.		
3202	Layer			0.13	Alluvial Layer. Mid blueish grey with reddish mottling. Silty clay.		
3203	Layer			0.1	Natural. Mid reddish brown sandy and clayey silt. Head deposit.		
3204	Layer			0.12	Alluvial Layer. Mid reddish brown silty clay.		
3205	Layer				Natural. Mid reddish brown clayey silt with blueish grey mottling. Bedrock.		
Trench 33							
General description					Orientation		E-W
Trench devoid of archaeology. Consists of ploughsoil and subsoil overlying a leached horizon, head deposit and bedrock.					Length (m)		30
					Width (m)		2
					Avg. depth (m)		0.5
Context No.	Type	Fill Of	Width (m)	Depth (m)	Description	Finds	Date
3300	Layer			0.3	Ploughsoil. Dark brownish grey silty clay.		
3301	Layer			0.2	Subsoil. Mid olive green clayey silt.		
3302	Layer			0.15	Other Layer. Mid blueish brown silty clay. Leached horizon?		
3303	Layer			0.3	Natural. Mid reddish brown clayey sandy silt with frequent gravels. Head deposit.		
3304	Layer				Natural. Mid reddish brown silty clay with blueish grey mottling. London clay bedrock.		
Trench 34							
General description					Orientation		ENE-WSW
Trench devoid of archaeology. Consists of ploughsoil and subsoil overlying a natural of silty clay.					Length (m)		30
					Width (m)		2
					Avg. depth (m)		0.45
Context No.	Type	Fill Of	Width (m)	Depth (m)	Description	Finds	Date
3400	Layer			0.34	Ploughsoil. Dark greyish brown clayey silt.		

3401	Layer			0.11	Subsoil. Mid greyish brown silty clay.		
3402	Layer				Natural. Mid yellowish brown sandy clay with gravel.		
Trench 35							
General description					Orientation		NNW-SSE
Trench devoid of archaeology. Consists of ploughsoil overlying subsoil and natural.					Length (m)		30
					Width (m)		2
					Avg. depth (m)		0.49
Context No.	Type	Fill Of	Width (m)	Depth (m)	Description	Finds	Date
3500	Layer			0.27	Ploughsoil. Dark greyish brown clayey silt.		
3501	Layer			0.22	Subsoil. Mid greyish brown silty clay.		
3502	Layer				Natural. Light yellowish brown silty clay.		
3503	Layer			0.2	Other Layer. Mid brown silty clay.		
Trench 36							
General description					Orientation		ENE-WSW
Trench devoid of archaeology. Consists of ploughsoil and subsoil overlying a natural of silty clay.					Length (m)		30
					Width (m)		2
					Avg. depth (m)		0.43
Context No.	Type	Fill Of	Width (m)	Depth (m)	Description	Finds	Date
3600	Layer			0.33	Ploughsoil. Dark greyish brown clayey silt.		
3601	Layer			0.1	Subsoil. Mid greyish brown silty clay.		
3602	Layer				Natural. Mid yellowish brown silty clay with patches of pale bluish grey.		
Trench 37							
General description					Orientation		E-W
Trench devoid of archaeological features. Consists of ploughsoil, alluvium overlying stabilisation horizon. This seals a sequence of alluviums and possible buried soil over a leached horizon (containing flints). Brickearth type deposit below, on top of weathered and natural bedrock. Sondage excavated at W. end to 1.6m.					Length (m)		30
					Width (m)		6
					Avg. depth (m)		0.6
Context No.	Type	Fill Of	Width (m)	Depth (m)	Description	Finds	Date
3700	Layer			0.28	Ploughsoil. Mid greyish brown silt clay.		
3701	Layer			0.06	Alluvial Layer. Mid yellowish brown mottled by mid grey sediment silty clay.		
3702	Layer			0.04	Other Layer. Stabilisation horizon Mid greyish brown mottled by dark black charcoal. Clayey silt.	Flint, FC (Briq')	
3703	Layer			0.16	Alluvial Layer. Mid greyish brown mottled by mid yellowish brown. Slightly silty clay.		
3704	Layer			0.06	Buried soil. Strong brown mottled by mid greyish brown. Silty clay, slightly humic.		

3705	Layer			0.04	Alluvial Layer. Pe greyish brown mottled by light yellow. Silty clay.		
3706	Layer			0.09	Alluvial Layer. Mid greyish brown mottled with strong brown. Silty clay.		
3707	Layer			0.12	Alluvial Layer. Pale greenish grey mottled with mid reddish brown oxidisation, slightly sandy clayey silt.		
3708	Layer			0.14	Other Layer. Leached horizon Pale bluish grey mottled by mid reddish brown. Slightly clayey silt.		
3709	Layer			0.48	Other Layer. Brickearth type deposit. Pale yellowish brown mottled by a subtle pale grey. Silty clay.		
3710	Layer			0.2	Natural. Weathered bedrock Mid reddish brown mottled with mid grey. Slightly clayey silt.		
3711	Layer			0.22	Natural. Bedrock Light reddish brown mottled by mid bluish grey. Slightly silty clay.		

Trench 38

General description		Orientation	NE-SW
Trench devoid of archaeology. Consists of ploughsoil overlying alluvium, leached horizon, head deposit and alluvium. Sondage excavated to 3m at E. end.		Length (m)	30
		Width (m)	6
		Avg. depth (m)	2

Context No.	Type	Fill Of	Width (m)	Depth (m)	Description	Finds	Date
3800	Layer			0.26	Ploughsoil. Dark blackish grey. clayey silt.		
3801	Layer			0.08	Alluvial Layer. Mottled mid greyish brown silty clay.		
3802	Layer			0.06	Other Layer. Dark blackish grey clayey silt. Organic rich silt? Buried soil?		
3803	Layer			0.13	Alluvial Layer. Mid yellowish brown silty clay.		
3804	Layer			0.17	Alluvial Layer. Dark greyish brown clayey silt.		
3805	Layer			0.14	Alluvial Layer. Mid greyish brown clayey silt.		
3806	Layer			0.25	Alluvial Layer. Dark blueish grey clayey silt.		
3807	Layer			0.27	Alluvial Layer. Light grey clayey silt.		
3808	Layer			0.13	Alluvial Layer. Mid blueish grey clayey silt.		
3809	Layer			0.26	Alluvial Layer. Dark blueish brown clayey silt.		
3810	Layer				Alluvial Layer. Mid blueish grey clayey silt.		
3811	Layer			0.08	Other Layer. Mid blueish grey sandy and clayey silt. Leached horizon.		
3812	Layer			0.37	Other Layer. Mid reddish brown clayey silt. Head deposit.		
3813	Layer				Alluvial Layer. Light blueish grey silty clay.		
3814	Layer			0.5	Alluvial Layer. Mid greyish blue silty clay with green mottling.		

Trench 39							
General description					Orientation		E-W
Trench devoid of archaeology. Consisting of ploughsoil and subsoil covering a leached horizon deposit overlying head deposits.					Length (m)		30
					Width (m)		2
					Avg. depth (m)		0.47
Context No.	Type	Fill Of	Width (m)	Depth (m)	Description	Finds	Date
3900	Layer			0.2	Ploughsoil. Dark brownish grey silty clay.		
3901	Layer			0.13	Subsoil. Mid brownish grey silty clay.		
3902	Layer			0.14	Other Layer. Light bluish grey silty clay. Leached horizon.		
3903	Layer			0.16	Natural. Light reddish brown sandy clay and gravel. Head deposit.		
3904	Layer				Natural. Mottled yellowish and reddish brown sandy clay and gravel.		
Trench 40							
General description					Orientation		NW-SE
Trench devoid of archaeology. Consists of ploughsoil and subsoil overlying a leached horizon and head deposit.					Length (m)		30
					Width (m)		2
					Avg. depth (m)		0.45
Context No.	Type	Fill Of	Width (m)	Depth (m)	Description	Finds	Date
4000	Layer			0.25	Ploughsoil. Dark brownish grey silty clay.		
4001	Layer			0.2	Subsoil. Mid olive green clayey silt.		
4002	Layer			0.45	Other Layer. Mid blueish brown silty clay. Leached horizon?		
4003	Layer				Natural. Mid reddish brown clayey silt with gravels. Head deposit.		
Trench 41							
General description					Orientation		ENE-WSW
Trench revealed a large natural feature, initially interpreted as a tree throw and a ditch. Consists of ploughsoil and subsoil overlying a silty clay natural.					Length (m)		30
					Width (m)		2
					Avg. depth (m)		0.45
Context No.	Type	Fill Of	Width (m)	Depth (m)	Description	Finds	Date
4100	Layer			0.3	Ploughsoil. Dark greyish brown clayey silt.		
4101	Layer			0.15	Subsoil. Mid greyish brown silty clay.		
4102	Layer				Natural. Mid yellow and reddish brown silty clay with gravel.		
4103	Cut		0.8	0.18	Natural Feature		
4104	Fill	4103	0.8	0.18	Primary Fill. Dark brownish grey, silty clay.		
4105	Cut		1.02	0.11	Tree Throw		
4106	Fill	4105	1.02	0.11	Primary Fill. Dark greyish brown, silty clay.		

Trench 42								
General description						Orientation		NNW-SSE
Trench devoid of archaeology. Consists of ploughsoil and subsoil overlying a natural of silty clay.						Length (m)		30
						Width (m)		2
						Avg. depth (m)		0.38
Context No.	Type	Fill Of	Width (m)	Depth (m)	Description	Finds	Date	
4200	Layer			0.27	Ploughsoil. Dark greyish brown clayey silt.			
4201	Layer			0.11	Subsoil. Mid greyish brown silty clay.			
4202	Layer				Natural. Light yellow and reddish brown with gravel.			
4203	Cut		0.89	0.1	Natural Feature. Mid grey, brown mottled, silty clay.			
Trench 43								
General description						Orientation		ENE-WSW
Trench devoid of archaeology. Consists of ploughsoil and subsoil overlying a natural of silty clay and gravel.						Length (m)		30
						Width (m)		2
						Avg. depth (m)		0.41
Context No.	Type	Fill Of	Width (m)	Depth (m)	Description	Finds	Date	
4300	Layer			0.26	Ploughsoil. Dark greyish brown clayey silt.			
4301	Layer			0.15	Subsoil. Mid greyish brown silty clay.			
4302	Layer				Natural. Mid yellowish brown silty clay with gravel.			
4303	Cut		0.83	0.11	Natural Feature. Mid grey, brown mottled silty clay.			
Trench 44								
General description						Orientation		NNW-SSE
Trench devoid of archaeological features. Consists of ploughsoil and subsoil overlying an alluvial layer over natural geology of silty clay. Struck flints came from the surface of the natural.						Length (m)		30
						Width (m)		2
						Avg. depth (m)		0.41
Context No.	Type	Fill Of	Width (m)	Depth (m)	Description	Finds	Date	
4400	Layer			0.27	Ploughsoil. Dark greyish brown clayey silt.	Flint		
4401	Layer			0.14	Alluvial Layer. Mid greyish brown silty clay.			
4402	Layer			0.13	Natural. Mid yellowish brown silty clay with gravel.	Flint, FC		
4403	Layer			0.13	Subsoil. Mid yellowish brown silty clay.			
Trench 45								
General description						Orientation		NNE-SSW

Trench devoid of archaeology. Consists of ploughsoil overlying a natural of silty clay.						Length (m)		30
						Width (m)		2
						Avg. depth (m)		0.24
Context No.	Type	Fill Of	Width (m)	Depth (m)	Description	Finds	Date	
4500	Layer			0.24	Ploughsoil. Dark greyish brown clayey silt.	Flint		
4501	Layer				Natural. Mid yellowish brown mottled with light greyish brown silty clay.			
4502	Void							
Trench 46								
General description						Orientation		E-W
Trench devoid of archaeological features. Consists of ploughsoil and subsoil over alluvial clay layers (at eastern end of trench), within which was a buried soil (containing a struck flint), and which overly the natural. Gently sloping to the east. Excavated to a max depth of 2m.						Length (m)		30
						Width (m)		6
						Avg. depth (m)		0.95
Context No.	Type	Fill Of	Width (m)	Depth (m)	Description	Finds	Date	
4600	Layer			0.23	Ploughsoil. Dark greyish brown clayey silt.			
4601	Layer			0.07	Subsoil. Dark grey silty clay.			
4602	Layer			0.16	Alluvial Layer. Dark blackish grey silty clay.			
4603	Layer			0.21	Alluvial Layer. Dark grey clay.			
4604	Layer			0.07	Buried soil. Mid grey clay.	Flint		
4605	Layer			0.1	Alluvial Layer. Light grey silty clay.			
4606	Layer			0.11	Alluvial Layer. Brown clay.			
4607	Layer			0.3	Other Layer. Mid brown clay. Stony band present.			
4608	Layer			0.54	Natural. Mid brown clay with calcite inclusions.			
4609	Layer			0.12	Other Layer. Dark brownish grey silty clay.			
4610	Layer			0.08	Other Layer. Light yellow/grey brown silty clay.			
4611	Layer			0.14	Other Layer. Mid reddish brown silty clay.			
4612	Layer			0.53	Alluvial Layer. Mid reddish brown clay.			
4613	Layer			0.25	Alluvial Layer. Mid reddish brown clay.			
4614	Layer			0.16	Alluvial Layer. Mid reddish brown clayey sand.			
4615	Layer				Natural. Mid brownish red London clay.			
Trench 47								
General description						Orientation		ENE-WSW
Trench devoid of archaeology. Consists of ploughsoil overlying organic alluvial and silty clay alluvium layers. A weathered bedrock at base. Excavated to a max depth of 2m.						Length (m)		30
						Width (m)		6
						Avg. depth (m)		0.88
Context No.	Type	Fill Of	Width (m)	Depth (m)	Description	Finds	Date	

4700	Layer			0.28	Ploughsoil. Dark greyish brown clayey silt.		
4701	Layer			0.19	Subsoil. Light greyish brown silty clay.		
4702	Layer			0.07	Other Layer. Mid reddish brown silty clay with lenses of bluish black peaty material.		
4703	Layer			0.17	Alluvial Layer. Light greyish brown silty clay.		
4704	Layer			0.17	Other Layer. Dark bluish brown peaty layer.		
4705	Layer			1.12	Alluvial Layer. Mid bluish grey silty clay.		

Trench 48

General description				Orientation		E-W	
Trench devoid of archaeology. Consists of ploughsoil and subsoil covering some alluvial layers and the geological ground, which slopes down towards the west.				Length (m)		30	
				Width (m)		6	
				Avg. depth (m)		0.55	

Context No.	Type	Fill Of	Width (m)	Depth (m)	Description	Finds	Date
4800	Layer			0.28	Ploughsoil. Dark greyish brown clayey silt with infrequent yellowish brown mottling.		
4801	Layer			0.11	Alluvial Layer. Yellowish brown clayey silt with frequent dark greyish brown mottling.		
4802	Layer			0.08	Buried soil. Dark greyish brown clayey silt with frequent very dark greyish brown and infrequent yellowish brown mottling.		
4803	Layer			0.16	Buried soil. Light brownish grey sandy clayey silt with frequent reddish brown mottling. Leached horizon.		
4804	Layer			0.12	Alluvial Layer. Brownish grey sandy clay with frequent reddish brown mottling. Frequent gravel. Head deposit.		
4805	Layer			0.38	Alluvial Layer. Light reddish brown silty clay with frequent light grey mottling. Infrequent coarse whitish yellow sand. Head deposit.		
4806	Layer			0.5	Natural. Light reddish brown silty clay with frequent grey mottling and frequent grey veins. Weathered bedrock.		
4807	Layer				Natural. Reddish brown clay with frequent grey mottling and frequent grey veins.		

Trench 49

General description				Orientation		E-W	
Trench devoid of archaeology. Consisting of ploughsoil, subsoil and a head deposit overlying London clay bedrock.				Length (m)		30	
				Width (m)		6	
				Avg. depth (m)		0.45	

Context No.	Type	Fill Of	Width (m)	Depth (m)	Description	Finds	Date
-------------	------	---------	-----------	-----------	-------------	-------	------

4900	Layer			0.2	Ploughsoil. Dark black, silty clay.		
4901	Layer			0.25	Subsoil. Mid olive green clayey silt.		
4902	Layer			0.35	Natural. Mid reddish brown clayey silt with gravels. Head deposit.		
4903	Layer				Natural. Mid reddish brown with blueish grey mottling. Silty clay. Bedrock.		

Trench 50

General description					Orientation		E-W
Trench devoid of archaeology. Consists of ploughsoil and subsoil overlying natural geology of sandy clay and gravel.					Length (m)		30
					Width (m)		2
					Avg. depth (m)		0.44
Context No.	Type	Fill Of	Width (m)	Depth (m)	Description	Finds	Date
5000	Layer			0.27	Ploughsoil. Dark black silty clay.		
5001	Layer			0.17	Subsoil. Light yellowish grey silty clay.		
5002	Layer				Natural. Mottled yellow and reddish brown sandy clay and gravel.		

Trench 51

General description					Orientation		E-W
Trench devoid of archaeology. Consisting of ploughsoil and subsoil covering a leached horizon deposit and natural.					Length (m)		30
					Width (m)		2
					Avg. depth (m)		0.53
Context No.	Type	Fill Of	Width (m)	Depth (m)	Description	Finds	Date
5100	Layer			0.28	Ploughsoil. Dark brownish grey silty clay.		
5101	Layer			0.1	Subsoil. Light yellowish grey silty clay.		
5102	Layer			0.15	Other Layer. Light yellowish grey silty clay. Leached horizon.		
5103	Layer				Natural. Mid reddish brown clayey sand and gravel.		

Trench 52

General description					Orientation		N-S
Trench devoid of archaeology. Consists of ploughsoil and subsoil on silty clay natural with frequent gravel patches.					Length (m)		30
					Width (m)		2
					Avg. depth (m)		0.45
Context No.	Type	Fill Of	Width (m)	Depth (m)	Description	Finds	Date
5200	Layer			0.28	Ploughsoil. Dark black silty clay.		
5201	Layer			0.17	Subsoil. Light yellowish grey silty clay.		
5202	Layer				Natural. Mottled red and yellowish brown sandy clay and gravel.		

Trench 53

General description					Orientation		NNW-SSE
					Length (m)		30

Trench devoid of archaeology. Consists of ploughsoil and subsoil overlying a natural of silty clay.						Width (m)	2
						Avg. depth (m)	0.42
Context No.	Type	Fill Of	Width (m)	Depth (m)	Description	Finds	Date
5300	Layer			0.31	Ploughsoil. Dark greyish brown clayey silt.		
5301	Layer			0.11	Subsoil. Mid greyish brown silty clay.		
5302	Layer				Natural. Mid yellowish brown silty clay.		
Trench 54							
General description						Orientation	ENE-WSW
Trench devoid of archaeology. Consists of ploughsoil and subsoil overlying a natural of silty clay and gravel.						Length (m)	30
						Width (m)	2
						Avg. depth (m)	0.38
Context No.	Type	Fill Of	Width (m)	Depth (m)	Description	Finds	Date
5400	Layer			0.28	Ploughsoil. Dark greyish brown clayey silt.		
5401	Layer			0.1	Subsoil. Mid greyish brown silty clay.		
5402	Layer				Natural. Mid reddish brown silty clay with gravel.		
5403	Cut		0.62	0.06	Natural Feature. Mid grey, brown mottled, silty clay.		
Trench 55							
General description						Orientation	NNW-SSE
Trench containing a tree-throw hole. Consists of ploughsoil and subsoil overlying a tree-throw hole and natural of silty clay. A struck flint came from the surface of the natural.						Length (m)	30
						Width (m)	2
						Avg. depth (m)	0.48
Context No.	Type	Fill Of	Width (m)	Depth (m)	Description	Finds	Date
5500	Layer			0.34	Ploughsoil. Dark greyish brown clayey silt.		
5501	Layer			0.14	Subsoil. Mid greyish yellow brown silty clay.		
5502	Layer			0.58	Natural. Mid reddish brown clay.	Flint	
5503	Cut				Tree Throw		
5504	Layer			0.56	Natural. Mid grey brown clay with reddish yellow mottling.		
5505	Layer			0.15	Natural. Dark red brown clay with abundant small pebbles.		
Trench 56							
General description						Orientation	ENE-WSW
Trench devoid of archaeology. Consists of ploughsoil and subsoil overlying a silty clay and gravel natural.						Length (m)	30
						Width (m)	2
						Avg. depth (m)	0.38
Context No.	Type	Fill Of	Width (m)	Depth (m)	Description	Finds	Date

5600	Layer			0.25	Ploughsoil. Dark greyish brown clayey silt.		
5601	Layer			0.13	Subsoil. Mid greyish brown silty clay.		
5602	Layer				Natural. Mid reddish brown silty clay with gravel.		

Trench 57

General description					Orientation		NE-SW
Trench devoid of archaeology. Consists of ploughsoil and subsoil overlying head deposits, weathered bedrock and bedrock.					Length (m)		30
					Width (m)		6
					Avg. depth (m)		0.39

Context No.	Type	Fill Of	Width (m)	Depth (m)	Description	Finds	Date
5700	Layer			0.32	Ploughsoil. Dark greyish brown clayey silt.		
5701	Layer			0.06	Subsoil. Mid grey silty clay.		
5702	Layer			0.17	Other Layer. Mid yellowish grey slightly sandy and clayey silt. Head deposit.		
5703	Layer			0.08	Other Layer. Mid blueish grey with mid reddish brown mottling slightly sandy and clayey silt. Head deposit.		
5704	Layer			0.19	Other Layer. Mid reddish grey slightly sandy and silty clay. Head deposit.		
5705	Layer			0.55	Natural. Mid reddish brown clayey silt. Weathered bedrock.		
5706	Layer				Natural. Mid brown with mid blueish grey veins slightly silty clay. Bedrock.		

Trench 58

General description					Orientation		NW-SE
Trench is devoid of archaeology. Consists of ploughsoil and subsoil overlying a natural of silty clay.					Length (m)		30
					Width (m)		2
					Avg. depth (m)		0.41

Context No.	Type	Fill Of	Width (m)	Depth (m)	Description	Finds	Date
5800	Layer			0.32	Ploughsoil. Dark greyish brown clayey silt.		
5801	Layer			0.09	Subsoil. Mid greyish brown silty clay.		
5802	Layer				Natural. Mid yellowish brown silty clay with patches of pale bluish brown.		

Trench 59

General description					Orientation		NNE-SSW
Trench devoid of archaeology. Consists of ploughsoil and subsoil overlying two layers of clayey silt head deposits over natural London clay bedrock. Excavated to a max depth of 2m.					Length (m)		30
					Width (m)		6
					Avg. depth (m)		0.45

Context No.	Type	Fill Of	Width (m)	Depth (m)	Description	Finds	Date
5900	Layer			0.27	Ploughsoil. Dark greyish brown clayey silt.		
5901	Layer			0.18	Subsoil. Mid greyish brown silty clay.		

5902	Layer			0.15	Natural. Mid brown silty clay.		
5903	Layer			0.19	Other Layer. Light reddish brown silty clay.		
5904	Layer			0.44	Other Layer. Light greyish brown silty clay. Weathered top of London Clay bedrock.		

Trench 60

General description				Orientation		NE-SW	
Trench without archaeological features. Consists of ploughsoil overlying alluvial deposits, which included a leached horizon with a struck flint, a head deposit and bedrock.				Length (m)		30	
				Width (m)		6	
				Avg. depth (m)		2	

Context No.	Type	Fill Of	Width (m)	Depth (m)	Description	Finds	Date
6000	Layer			0.27	Ploughsoil. Mid greyish brown clayey silt.		
6001	Layer			0.35	Alluvial Layer. Mottled light yellowish brown clayey silt.		
6002	Layer			0.1	Other Layer. Dark blackish grey slightly clayey silt. Organic rich silt?		
6003	Layer			0.16	Alluvial Layer. Dark grey clayey silt.		
6004	Layer			0.13	Alluvial Layer. Dark blackish brown slightly clayey silt. Organic rich silt? Peaty		
6005	Layer			0.17	Alluvial Layer. Dark blueish grey clayey silt. Brackish alluvium?		
6006	Layer			0.41	Alluvial Layer. Mid greyish brown slightly clayey silt.	Pot	IA
6007	Layer			0.14	Alluvial Layer. Dark grey slightly clayey silt.		
6008	Layer			0.11	Other Layer. Light grey slightly clayey silt. Leached horizon.	Flint	
6009	Layer			0.5	Alluvial Layer. Light blueish grey silty clay.		
6010	Layer			0.3	Other Layer. Mid reddish brown silty clay. Head deposit.		
6011	Layer				Natural. Mid greyish brown silty clay. Bedrock.		

Trench 61

General description				Orientation		NNW-SSE	
Trench without archaeological features. Consists of ploughsoil and subsoil overlying a sand and gravel deposit with struck flint over a head deposit of silty clay and gravel. On top of natural London clay. Sondage dug to max depth of 1m at NNW end of trench.				Length (m)		30	
				Width (m)		2	
				Avg. depth (m)		0.44	

Context No.	Type	Fill Of	Width (m)	Depth (m)	Description	Finds	Date
6100	Layer			0.28	Ploughsoil. Dark greyish brown clayey silt.	Flint	
6101	Layer			0.16	Subsoil. Mid yellowish brown clayey silt.		
6102	Layer			0.1	Other Layer. Mid greyish brown clayey sand heavily mottled with dark reddish brown oxidation. Abundant gravel.	Flint	

6103	Layer			0.24	Other Layer. Dark yellow greyish brown clayey sand with frequent gravel.		
6104	Layer			0.24	Natural. Mid greyish brown mottled with light yellowish brown silty clay.		

Trench 62

General description					Orientation		ENE-WSW
Trench devoid of archaeology. Consists of ploughsoil and subsoil overlying a natural of silty clay and gravel.					Length (m)		30
					Width (m)		2
					Avg. depth (m)		0.41
Context No.	Type	Fill Of	Width (m)	Depth (m)	Description	Finds	Date
6200	Layer			0.3	Ploughsoil. Dark greyish brown clayey silt.		
6201	Layer			0.11	Subsoil. Mid greyish brown silty clay.		
6202	Layer				Natural. Mid yellow and reddish brown silty clay with gravel.		

Trench 63

General description					Orientation		NNW-SSE
Trench devoid of archaeology. Consists of ploughsoil and subsoil overlying a natural of silty clay.					Length (m)		30
					Width (m)		2
					Avg. depth (m)		0.38
Context No.	Type	Fill Of	Width (m)	Depth (m)	Description	Finds	Date
6300	Layer			0.26	Ploughsoil. Dark greyish brown clayey silt.	Flint	
6301	Layer			0.12	Subsoil. Mid greyish brown silty clay.		
6302	Layer				Natural. Mid reddish brown silty clay.		

Trench 64

General description					Orientation		ENE-WSW
Trench devoid of archaeology. Consists of ploughsoil overlying subsoil and natural.					Length (m)		30
					Width (m)		2
					Avg. depth (m)		0.44
Context No.	Type	Fill Of	Width (m)	Depth (m)	Description	Finds	Date
6400	Layer			0.33	Ploughsoil. Dark greyish brown clayey silt.		
6401	Layer			0.11	Subsoil. Mid greyish brown silty clay.		
6402	Layer				Natural. Light yellowish brown silty clay with gravel.		

Trench 65

General description					Orientation		NNW-SSE
Trench devoid of archaeology. Consists of ploughsoil overlying subsoil and natural.					Length (m)		30
					Width (m)		2

						Avg. depth (m)	0.39
Context No.	Type	Fill Of	Width (m)	Depth (m)	Description	Finds	Date
6500	Layer			0.28	Ploughsoil. Dark greyish brown clayey silt.		
6501	Layer			0.11	Subsoil. Mid greyish brown silty clay.		
6502	Layer				Natural. Brownish yellow silty clay with gravel.		
6503	Cut		0.21	0.01	Natural Feature		
Trench 66							
General description						Orientation	ENE-WSW
Trench devoid of archaeology. Consists of ploughsoil overlying subsoil and natural.						Length (m)	30
						Width (m)	2
						Avg. depth (m)	0.42
Context No.	Type	Fill Of	Width (m)	Depth (m)	Description	Finds	Date
6600	Layer			0.32	Ploughsoil. Dark greyish brown clayey silt.		
6601	Layer			0.1	Subsoil. Mid greyish brown silty clay.		
6602	Layer				Natural. Mid yellowish grey silty clay with gravel.		
6603	Cut		0.37	0.09	Natural Feature. Mid grey, brown silty clay.		
Trench 67							
General description						Orientation	NNW-SSE
Trench devoid of archaeology. Consists of ploughsoil overlying subsoil and natural.						Length (m)	30
						Width (m)	2
						Avg. depth (m)	0.42
Context No.	Type	Fill Of	Width (m)	Depth (m)	Description	Finds	Date
6700	Layer			0.3	Ploughsoil. Dark greyish brown clayey silt.		
6701	Layer			0.12	Subsoil. Mid greyish brown silty clay.		
6702	Layer				Natural. Light reddish brown with gravel.		
Trench 68							
General description						Orientation	ENE-WSW
Trench devoid of archaeology. Consists of ploughsoil overlying subsoil and natural.						Length (m)	30
						Width (m)	2
						Avg. depth (m)	0.35
Context No.	Type	Fill Of	Width (m)	Depth (m)	Description	Finds	Date
6800	Layer			0.24	Ploughsoil. Dark greyish brown, clayey silt.		
6801	Layer			0.11	Subsoil. Greyish brown, silty clay.		
6802	Layer				Natural. Mid reddish brown silty clay.		

Trench 69							
General description					Orientation		NNW-SSE
Trench revealed one posthole. Consists of ploughsoil over subsoil overlying the posthole cut into the natural. Struck flints and pottery came from the surface of the natural					Length (m)		30
					Width (m)		2
					Avg. depth (m)		0.39
Context No.	Type	Fill Of	Width (m)	Depth (m)	Description	Finds	Date
6900	Layer			0.3	Ploughsoil. Dark greyish brown clayey silt.		
6901	Layer			0.09	Subsoil. Mid reddish, grey brown clayey silt.		
6902	Layer				Natural. Mid yellowish brown silty clay.	Pot, Flint	MBA-MIA
6903	Void						
6904	Void						
6905	Cut		0.21	0.05	Posthole		
6906	Fill	6905	0.21	0.05	Primary Fill. Dark brown grey, silty clay.		
6907	Void						
Trench 70							
General description					Orientation		NNW-SSE
Trench devoid of archaeology. Consists of ploughsoil and subsoil overlying a silty clay natural. Excavated to max 2m depth at southern end.					Length (m)		30
					Width (m)		6
					Avg. depth (m)		0.55
Context No.	Type	Fill Of	Width (m)	Depth (m)	Description	Finds	Date
7000	Layer			0.32	Ploughsoil. Dark greyish brown clayey silt.		
7001	Layer			0.23	Subsoil. Mid yellowish brown silty clay.		
7002	Layer				Natural. Mid reddish brown silty clay.		
Trench 71							
General description					Orientation		NNW-SSE
Trench devoid of archaeology. Consists of ploughsoil and subsoil overlying a silty clay natural. Excavated to a max depth of 2m at southern end.					Length (m)		30
					Width (m)		6
					Avg. depth (m)		0.4
Context No.	Type	Fill Of	Width (m)	Depth (m)	Description	Finds	Date
7100	Layer			0.28	Ploughsoil. Dark greyish brown clayey silt.		
7101	Layer			0.12	Subsoil. Mid greyish brown silty clay.		
7102	Layer				Natural. Mid reddish brown silty clay.		
Trench 72							
General description					Orientation		NW-SE
					Length (m)		30

Trench revealed a flint scatter. Consists of ploughsoil, lower topsoil and alluvial layers overlying a 'leached horizon' with flint upon it over a silty clay natural.						Width (m)	6
						Avg. depth (m)	0.74
Context No.	Type	Fill Of	Width (m)	Depth (m)	Description	Finds	Date
7200	Layer			0.22	Ploughsoil. Dark greyish brown clayey silt.		
7201	Layer			0.1	Other Layer. Dark blackish grey clayey silt. Lower topsoil.		
7202	Layer			0.1	Alluvial Layer. Dark reddish brown clayey silt.		
7203	Layer			0.12	Alluvial Layer. Dark brownish grey silty clay.		
7204	Layer			0.08	Alluvial Layer. Mid brownish grey silty clay with yellow mottling.		
7205	Layer				Other Layer. Flint scatter event.	Flint	
7206	Layer			0.12	Other Layer. Light bluish grey sandy clay. Leached Horizon.		
7207	Layer			0.14	Natural. Light brownish yellow sandy clay with grey mottling.		
7208	Layer				Natural. Mid reddish brown silty clay. Brick Earth.		

Trench 73

General description						Orientation	NE-SW
Trench devoid of archaeology. Consists of ploughsoil over alluvial layers with a peat layer as well as brick-earth type deposit/head deposit over natural London Clay. A Pleistocene deposit of interest is found on north end of trench in S7301.						Length (m)	30
						Width (m)	6
						Avg. depth (m)	0.92
Context No.	Type	Fill Of	Width (m)	Depth (m)	Description	Finds	Date
7300	Layer			0.18	Ploughsoil. Dark grey brown, silty clay.		
7301	Layer			0.16	Alluvial Layer. Soft mid yellowish brown silty clay mottled with mid grey		
7302	Layer			0.02	Other Layer. Friable dark greyish brown silty clay. Humic. Stabilisation horizon.		
7303	Layer			0.12	Alluvial Layer. Soft mid brown grey silty clay with reddish yellow fe mottling		
7304	Layer			0.1	Alluvial Layer. Firm mid greyish brown silty clay		
7305	Layer			0.1	Other Layer. Friable dark reddish brown to very dark brown silty peat bands. Peat.		
7306	Layer			0.02	Alluvial Layer. Soft grey clayey silt		
7307	Layer			0.04	Alluvial Layer. Soft dark reddish brown clayey silt.		
7308	Layer			0.16	Alluvial Layer. Soft pale brownish grey clayey silt		
7309	Layer			0.2	Natural. Soft grey Sandy clayey silt with pebbles. Brick earth type deposits/ head deposit		
7310	Layer			0.5	Natural. Firm mid reddish brown silty clay. Weathered bedrock		
7311	Layer			0.36	Natural. Firm mid reddish brown silty clay with bluish grey veins. Bedrock		

7312	Layer			0.23	Other Layer. Mid grey mottled by mid reddish brown oxidised sediment. Slightly sandy silty clay.		
7313	Layer			0.1	Alluvial Layer. Soft mid greyish brown clayey silt mottled with reddish brown fe oxidised		

Trench 74

General description					Orientation		N-S
Trench devoid of archaeology. Consists of ploughsoil overlying alluvial deposit, a stabilisation horizon. Underlying this is a another alluvial and a buried soil. A very thin band of alluvium is present overlying a head deposit and weathered bedrock before reaching Natural London clay.					Length (m)		30
					Width (m)		6
					Avg. depth (m)		1.22
Context No.	Type	Fill Of	Width (m)	Depth (m)	Description	Finds	Date
7400	Layer			0.2	Ploughsoil. Dark grey brown, firm silty clay.		
7401	Layer			0.24	Alluvial Layer. Mid yellowish brown mottled with a mid-greyish brown silty clay.		
7402	Layer			0.04	Other Layer. Thin dark greyish brown mottled with black, slightly humic. Clayey silt.		
7403	Layer			0.17	Alluvial Layer. Mid yellowish brown mottled by mid grey silty clay		
7404	Layer			0.05	Buried soil. Dark greyish brown slightly mottled by yellowish brown. Clayey silt. Humic		
7405	Layer			0.02	Alluvial Layer. Mid yellowish brown, silty clay		
7406	Layer			0.17	Other Layer. Mid bluish grey silty clay. Head deposit		
7407	Layer			0.38	Other Layer. Dark yellowish brown slightly silty clay Weathered bedrock		
7408	Layer			0.7	Natural. Dark/strong brown silty clay. With slightly bluish mottling 3%		
7409	Layer			0.04	Other Layer. Friable dark reddish brown silty peat		
7410	Layer			0.04	Other Layer. Soft very dark brown silty peat		
7411	Layer			0.06	Other Layer. Friable dark reddish brown silty peat		
7412	Layer			0.02	Alluvial Layer. Soft grey clayey silt		
7413	Layer			0.06	Alluvial Layer. Soft dark reddish brown clayey silt Organic alluvium		
7414	Layer			0.4	Alluvial Layer. Soft mid brown silty clay with organic material		
7415	Layer			0.16	Natural. Soft light brownish grey fine Sandy silt. Brick earth type deposits		

Trench 75

General description					Orientation		NE-SW
Trench devoid of archaeology. Consists of ploughsoil overlying alluvium, head deposits, weathered bedrock and bedrock.					Length (m)		30
					Width (m)		6
					Avg. depth (m)		0.72

Context No.	Type	Fill Of	Width (m)	Depth (m)	Description	Finds	Date
7500	Layer			0.28	Ploughsoil. Mid greyish brown clayey silt.		
7501	Layer			0.31	Alluvial Layer. Mottled mid yellowish brown clayey silt.		
7502	Layer			0.13	Alluvial Layer. Mottled mid greyish brown clayey silt. Buried soil?		
7503	Layer			0.1	Other Layer. Mid blueish grey slightly clayey silt. Leached horizon?		
7504	Layer			0.04	Other Layer. Mottled mid yellowish-reddish brown clayey silt. Head deposit.		
7505	Layer			0.57	Natural. Mid brown with mid blueish grey veins clayey silt. Weathered bedrock.		
7506	Layer				Natural. Mid brown with mid blueish grey veins silty clay. Bedrock.		
7507	Layer			0.15	Alluvial Layer. Mid grey clayey silt.		

Trench 76

General description					Orientation		NE-SW
Trench devoid of archaeology. Consists of ploughsoil overlying an alluvial deposit (and humic alluvium in the NE). Leached Horizon below this overlies head deposit weathered bedrock and natural bedrock (in the NW end of trench). Sondage excavated to 3m at SW end.					Length (m)		30
					Width (m)		6
					Avg. depth (m)		0.48

Context No.	Type	Fill Of	Width (m)	Depth (m)	Description	Finds	Date
7600	Layer			0.24	Ploughsoil. Friable Dark grey brown, silty clay.		
7601	Layer			0.15	Alluvial Layer. Soft mid yellowish brown silty clay with greyish brown mottling.		
7602	Layer			0.1	Other Layer. Leached horizon. Soft light yellow brown mottled with pale grey rooting clayey silt		
7603	Layer			0.2	Natural. Head deposit. Mottled Mid reddish brown clayey silt		
7604	Layer			0.7	Natural. Weathered bedrock. Soft mid greyish brown silty clay mottled with a mid-reddish brown.		
7605	Layer			0.63	Natural. Bedrock. Very firm mid reddish brown silty clay with bluish grey veins.		
7606	Layer			0.08	Alluvial Layer. Humic Alluvium. Firm dark greyish Sandy silty clay. Humic component.		
7607	Layer			0.3	Natural. Bedrock, LONDON CLAY FORMATION in 2.6 m deep pit at SE end		

Trench 77

General description					Orientation		NE-SW
Trench devoid of archaeology. Consists of ploughsoil overlying alluvium, head deposits, weathered bedrock and bedrock.					Length (m)		30
					Width (m)		6
					Avg. depth (m)		0.47

Context No.	Type	Fill Of	Width (m)	Depth (m)	Description	Finds	Date
-------------	------	---------	-----------	-----------	-------------	-------	------

7700	Layer			0.29	Ploughsoil. Mid greyish brown clayey silt.		
7701	Layer			0.17	Alluvial Layer. Mottled mid yellowish brown silty clay.		
7702	Layer			0.23	Other Layer. Mottled mid grey sandy silt. Head deposit, leached horizon?		
7703	Layer			0.21	Other Layer. Mid grey slightly sandy and silt clay. Head deposit.		
7704	Layer			0.64	Natural. Mid brown with mid blueish grey veins slightly clayey silt. Weathered bedrock.		
7705	Layer				Natural. Mid brown with mid blueish grey veins slightly silty clay. Bedrock.		

Trench 78

General description	Orientation	N-S
Trench devoid of archaeology. Consists of ploughsoil and subsoil overlying the head deposits and natural geology of London clay. Excavated to a total depth of 1.7m. Trench gently slopes to the south-west.	Length (m)	30
	Width (m)	6
	Avg. depth (m)	0.36

Context No.	Type	Fill Of	Width (m)	Depth (m)	Description	Finds	Date
7800	Layer			0.27	Ploughsoil. Dark grey brown, silty clay.		
7801	Layer			0.09	Subsoil. Mid brownish grey silty clay.		
7802	Layer			0.18	Natural. Mottled yellow and grey blue silty clay and gravel. Head deposit.		
7803	Layer				Natural. Mid reddish brown silty clay.		

Trench 79

General description	Orientation	NE-SW
Trench devoid of archaeological features. Consists of ploughsoil overlying alluvial deposits (including struck flint), possible buried soil and brick earth deposit over London Clay natural. Sondage excavated to 3m at S end.	Length (m)	30
	Width (m)	6
	Avg. depth (m)	

Context No.	Type	Fill Of	Width (m)	Depth (m)	Description	Finds	Date
7900	Layer			0.25	Ploughsoil. Dark grey brown, clayey silt.		
7901	Layer			0.22	Alluvial Layer. Mid brownish grey, clayey silt		
7902	Layer			0.06	Buried soil. Dark purplish brown, clayey silt		
7903	Layer			0.23	Alluvial Layer. Mid grey with mid reddish brown mottling. Clayey silt		
7904	Layer			0.12	Alluvial Layer. Light grey mottles by mid yellowish brown sandy silt	Flint	
7905	Layer			0.24	Other Layer. Mid brownish grey with mid orangey brown mottling silty clay Brickearth type deposit		
7906	Layer			0.45	Alluvial Layer. Mid brown clayey silty sand with grey mottling.		
7907	Layer			0.28	Natural. Mid brownish grey with mid orangey grey mottling. Clayey silt. Weathered bedrock		
7908	Layer			0.18	Natural. Bedrock Mid greyish brown silty clay		

Trench 80							
General description					Orientation		E-W
Trench devoid of archaeology. Consists of ploughsoil overlying subsoil which overlies a head deposit and bedrock.					Length (m)		30
					Width (m)		6
					Avg. depth (m)		0.46
Context No.	Type	Fill Of	Width (m)	Depth (m)	Description	Finds	Date
8000	Layer			0.24	Ploughsoil. Dark black, silty clay.		
8001	Layer			0.22	Subsoil. Mid olive green clayey silt.		
8002	Layer			0.34	Natural. Mid reddish brown sandy, clayey silt with gravels. Head deposit.		
8003	Layer				Natural. Mid reddish brown with blueish grey mottling. Silty clay. Bedrock.		
Trench 81							
General description					Orientation		NE-SW
Trench revealed one ditch. Consists of ploughsoil and subsoil overlying head deposit over London Clay.					Length (m)		30
					Width (m)		6
					Avg. depth (m)		0.44
Context No.	Type	Fill Of	Width (m)	Depth (m)	Description	Finds	Date
8100	Layer			0.24	Ploughsoil. Dark grey brown, silty clay.		
8101	Layer			0.2	Subsoil. Mid greyish brown silty clay.		
8102	Layer			0.41	Natural. Mid reddish brown sandy clay and gravel. Head deposit.		
8103	Layer				Natural. Mid greyish brown clay. London clay.		
8104	Cut		0.7	0.31	Ditch		
8105	Fill	8104	0.7	0.31	Primary Fill. Mid bluish grey silty clay.		
8106	Void						
Trench 82							
General description					Orientation		ENE-WSW
Trench devoid of archaeology. Consists of ploughsoil overlying subsoil and natural.					Length (m)		30
					Width (m)		2
					Avg. depth (m)		0.44
Context No.	Type	Fill Of	Width (m)	Depth (m)	Description	Finds	Date
8200	Layer			0.33	Ploughsoil. Dark greyish brown clayey silt.		
8201	Layer			0.11	Subsoil. Mid greyish brown silty clay.		
8202	Layer				Natural. Light yellowish brown silt clay.		
8203	Cut				Tree Throw		
8204	Fill	8203			Secondary Fill. Light grey charcoal rich fill.		
8205	Layer				Other Layer. Dark reddish brown gravelly clay.		

Trench 83							
General description					Orientation		NNW-SSE
Trench devoid of archaeology. Consists of ploughsoil overlying subsoil, overlying natural.					Length (m)		30
					Width (m)		2
					Avg. depth (m)		0.34
Context No.	Type	Fill Of	Width (m)	Depth (m)	Description	Finds	Date
8300	Layer			0.24	Ploughsoil. Dark greyish brown clayey silt		
8301	Layer			0.1	Subsoil. Mid reddish brown silty clay.		
8302	Layer				Natural. Light greyish yellow silty clay.		
Trench 84							
General description					Orientation		ENE-WSW
Trench devoid of archaeological features. Consists of ploughsoil overlying subsoil and natural. Struck flint and fired clay from surface of natural.					Length (m)		30
					Width (m)		2
					Avg. depth (m)		0.47
Context No.	Type	Fill Of	Width (m)	Depth (m)	Description	Finds	Date
8400	Layer			0.35	Ploughsoil. Dark greyish brown clayey silt.		
8401	Layer			0.12	Subsoil. Mid greyish red silty clay.		
8402	Layer				Natural. Light reddish brown silty clay.	Flint, FC	
Trench 85							
General description					Orientation		NNW-SSE
Trench devoid of archaeology. Consists of ploughsoil, subsoil and natural.					Length (m)		30
					Width (m)		2
					Avg. depth (m)		0.36
Context No.	Type	Fill Of	Width (m)	Depth (m)	Description	Finds	Date
8500	Layer			0.27	Ploughsoil. Dark grey brown clayey silt.		
8501	Layer			0.09	Subsoil. Mid greyish yellow silty clay.		
8502	Layer				Natural. Mid reddish brown silty clay with gravel.		
Trench 86							
General description					Orientation		ENE-WSW
Trench revealed a flint scatter concentrated towards the SW end. Consists of ploughsoil overlying subsoil and natural.					Length (m)		30
					Width (m)		2
					Avg. depth (m)		0.39
Context No.	Type	Fill Of	Width (m)	Depth (m)	Description	Finds	Date
8600	Layer			0.28	Ploughsoil. Dark greyish brown clayey silt.	Flint	
8601	Layer			0.11	Subsoil. Mid greyish brown silty clay.		

8602	Layer				Natural. Mid yellowish brown silty clay.		
8603	Layer				Other Layer. Flint scatter event.	Flint, Pot, FC	L.Meso/ E. Neo
8604	Layer			0.15	Other Layer. Moderately firm brownish grey to light brownish grey slightly clayey silt with lenses of brownish yellow silty clay		
8605	Layer			0.19	Other Layer. Firm light brown silt with Mg mottling (15- 20 %)	Flint	
8606	Layer			0.08	Other Layer. Firm brown to strong brown/yellowish brown clayey silt		
8607	Layer			0.08	Other Layer. Firm brown clayey silt		

Trench 87

General description						Orientation		NNW-SSE
Trench devoid of archaeology. Consists of ploughsoil and subsoil overlying natural.						Length (m)		30
						Width (m)		2
						Avg. depth (m)		0.35
Context No.	Type	Fill Of	Width (m)	Depth (m)	Description	Finds	Date	
8700	Layer			0.19	Ploughsoil. Dark grey brown, silty clay.			
8701	Layer			0.16	Subsoil. Light yellowish grey silty clay.			
8702	Layer				Natural. Mid reddish brown silty clay.			

Trench 88

General description						Orientation		ENE-WSW
Trench devoid of archaeology. Consists of ploughsoil overlying subsoil and natural.						Length (m)		30
						Width (m)		2
						Avg. depth (m)		0.33
Context No.	Type	Fill Of	Width (m)	Depth (m)	Description	Finds	Date	
8800	Layer			0.26	Ploughsoil. Dark greyish brown clayey silt.			
8801	Layer			0.07	Subsoil. Mid greyish brown silty clay.			
8802	Layer				Natural. Light yellowish brown silty clay with gravel.			

Trench 89

General description						Orientation		NNW-SSE
Trench devoid of archaeology. Consists of ploughsoil overlying subsoil and natural.						Length (m)		30
						Width (m)		2
						Avg. depth (m)		0.45
Context No.	Type	Fill Of	Width (m)	Depth (m)	Description	Finds	Date	
8900	Layer			0.35	Ploughsoil. Dark greyish brown clayey silt.			
8901	Layer			0.1	Subsoil. Mid greyish brown silty clay.			
8902	Layer				Natural. Light yellowish brown silty clay.			

Trench 90							
General description					Orientation		NE-SW
Trench revealed a flint scatter and cremation. Consists of ploughsoil and subsoil overlying a leached horizon and head deposit.					Length (m)		30
					Width (m)		2
					Avg. depth (m)		0.4
Context No.	Type	Fill Of	Width (m)	Depth (m)	Description	Finds	Date
9000	Layer			0.2	Ploughsoil. Dark greyish brown silty clay.		
9001	Layer			0.2	Subsoil. Mid yellowish brown silty clay.	Flint	
9002	Layer			0.2	Other Layer. Light greyish brown sandy clay. Leached Horizon.	Pot	MBA-MIA
9003	Layer				Natural. Dark reddish brown clayey silt. Head deposit?		
9004	Layer				Other Layer. Flint scatter event.	Flint	
9005	Cut		1.48	0.5	Natural Feature		
9006	Fill	9005	1.48	0.5	Secondary Fill. Mid reddish brown sandy clay.	Flint	Meso/ E Neo
9007	Cut		0.36	0.07	Cremation Cut		
9008	Fill	9007	0.36	0.07	Cremation Deposit. Charcoal rich greyish black sandy silt with occasional burnt bone.		
Trench 91							
General description					Orientation		NNW-SSE
Trench devoid of archaeology. Consists of ploughsoil overlying a shallow alluvial deposit brick earth type, gravel and sand head deposits overlying London Clay bedrock. Sondage excavated to 3m at S end.					Length (m)		30
					Width (m)		6
					Avg. depth (m)		0.53
Context No.	Type	Fill Of	Width (m)	Depth (m)	Description	Finds	Date
9100	Layer			0.31	Ploughsoil. Dark grey brown clay silt.		
9101	Layer			0.21	Alluvial Layer. Light grey brown silt clay.		
9102	Layer			0.19	Natural. Leached horizon Light grey silt sand with light orange mottling.		
9103	Layer			0.28	Natural. Brick earth type. Light brown silt sand clay with dark and mid brown mottling.		
9104	Layer			0.48	Natural. Mid grey brown clay sand silt with light grey mottling. Brick earth		
9105	Layer			0.03	Natural. Mid brown orange silt sand. Brick earth type layer.		
9106	Layer			0.22	Natural. Mid brown sand silt clay with patches of mid grey brown silt clay. Weathered bedrock.		
9107	Layer			0.35	Natural. Mid grey brown sand silt clay with patches of mid grey silt clay. Weathered bedrock		
9108	Layer			0.14	Natural. Mid grey brown sand silt with striations of dark brown sand silt. Bedrock		

9109	Layer			0.08	Natural. Firm dark reddish brown silty clay with manganese inclusions. Brick earth type layer		
9110	Layer			0.24	Natural. Soft mid reddish brown silty clay. Brick earth type layer		
9111	Layer			0.08	Natural. Loose mid brown silty gravel. Bedrock		
9112	Layer			0.45	Alluvial Layer. Loose brown grey gravel of small pebbles with light brown silt clay. Head deposit or Pleistocene deposit.		
9113	Layer				Natural. Dark olive grey with light blue grey veins, stiff silt clay. London Clay.		

Trench 92

General description					Orientation		NW-SEE
Trench devoid of archaeology. Consists of ploughsoil and subsoil overlying a 'leached horizon' and natural geology of clay and gravel.					Length (m)		30
					Width (m)		2
					Avg. depth (m)		0.55
Context No.	Type	Fill Of	Width (m)	Depth (m)	Description	Finds	Date
9200	Layer			0.26	Ploughsoil. Dark greyish brown silty clay.		
9201	Layer			0.14	Subsoil. Mid yellowish brown silty clay.		
9202	Layer			0.15	Other Layer. Light yellowish brown silty clay.		
9203	Layer				Natural. Dark reddish brown clay.		

Trench 93

General description					Orientation		NNW-SSE
Trench devoid of archaeology. Stratigraphy consists of ploughsoil over a shallow alluvial layer and substantial head deposits consisting of a leached horizon, brick earth type deposits and clayey gravel, overlying weathered bedrock and bedrock of the London Clay Formation.					Length (m)		30
					Width (m)		6
					Avg. depth (m)		0.56
Context No.	Type	Fill Of	Width (m)	Depth (m)	Description	Finds	Date
9300	Layer			0.24	Ploughsoil. Dark greyish brown silty clay.	Flint	
9301	Layer			0.18	Alluvial Layer. Dark yellowish brown silty clay.		
9302	Layer			0.14	Other Layer. Light yellowish grey leached horizon of clayey silt.		
9303	Layer			0.4	Other Layer. Mid yellowish brown silty clay brick earth deposit.		
9304	Layer			0.14	Other Layer. Light brown silty sandy clay Pleistocene brick earth deposit with thin gravel band.		
9305	Layer			0.22	Natural. Yellowish brown silty clay. BRICK EARTH TYPE DEPOSIT.		
9306	Layer			0.15	Natural. Light greyish brown clayey silt. BRICK EARTH TYPE DEPOSIT.		
9307	Layer			0.16	Natural. Yellowish brown mottled light yellowish brown sandy silty clay.		

9308	Layer			0.13	Natural. Dark yellowish brown sandy clay with frequent sub-angular small pebbles. HEAD DEPOSIT.		
9309	Layer			0.21	Natural. Yellowish brown silty clay. BRICK EARTH TYPE DEPOSIT.		
9310	Layer			0.71	Natural. Brownish grey clayey silt mottled strong brown and white		
9311	Layer			0.3	Natural. Stiff brown mottled Bluish grey clayey silt with mudstone cobbles. Bedrock.		

Trench 94

General description	Orientation	NNW-SSE
Trench without archaeological features. Consists of ploughsoil overlying alluvial deposits, leached brickearth (with struck flint) and palaeosol down to the head geology and London Clay bedrock. Excavated to a total depth of 2m with a 3m sondage excavated at the S. end.	Length (m)	30
	Width (m)	6
	Avg. depth (m)	0.3

Context No.	Type	Fill Of	Width (m)	Depth (m)	Description	Finds	Date
9400	Layer			0.3	Ploughsoil. Dark greyish brown silty clay.		
9401	Layer			0.45	Alluvial Layer. Mid brownish grey and light reddish brown clayey silt.		
9402	Layer			0.2	Alluvial Layer. Dark reddish brown and dark bluish grey silty clay.		
9403	Layer				Other Layer. Light greyish blue and light brownish red silty sand. Leached brickearth.	Flint	
9404	Layer			0.27	Other Layer. Dark reddish brown mottled with light grey and mid reddish brown silty clay.		
9405	Layer			0.12	Alluvial Layer. Light yellowish brown silty clay.		
9406	Layer			0.08	Buried soil. Palaeosol. Light grey with yellowish red speckling, silty clay.		
9407	Layer			0.22	Other Layer. Light reddish brown silty clay.		
9408	Layer				Other Layer. Reddish yellow sandy gravel. Head deposit.		
9409	Layer		4.1		Colluvial Layer. Brown sand.		
9410	Layer		1.4	0.7	Colluvial Layer. Light grey sandy clay.		
9411	Layer			0.24	Alluvial Layer. Mottled light brown and grey clay with dark grey clay.		
9412	Layer		3.38	0.3	Alluvial Layer. Light red clay.		
9413	Layer			0.24	Other Layer. Mid Bluish grey clay with frequent charcoal flecks.		
9414	Layer				Other Layer. Light brown silty clay.		
9415	Layer			0.14	Alluvial Layer. Mid grey silty clay.		
9416	Layer			0.4	Alluvial Layer. Mid greenish grey silty clay.		
9417	Layer				Natural. Mid bluish brown silty clay. Bedrock.		

Trench 95

General description	Orientation	E-W
---------------------	-------------	-----

Trench devoid of archaeology. Consists of ploughsoil and subsoil overlying head deposits.						Length (m)		30
						Width (m)		6
						Avg. depth (m)		0.36
Context No.	Type	Fill Of	Width (m)	Depth (m)	Description	Finds	Date	
9500	Layer			0.24	Ploughsoil. Dark greyish brown clayey silt.			
9501	Layer			0.1	Subsoil. Mid greyish brown. silty clay.			
9502	Layer			0.16	Natural. Mid yellowish brown silty clay. Head deposit.			
9503	Layer			0.23	Natural. Mid reddish brown clayey silt. Head deposit.			
9504	Layer			0.23	Natural. Mid brown clayey silt. Head deposit.			
9505	Layer			0.25	Natural. Mid reddish brown slightly sandy silt. Head deposit.			
9506	Layer			0.24	Natural. Mid brown slightly clayey and sandy silt. Head deposit.			
9507	Layer			0.51	Natural. Mid greyish brown slightly clayey and sandy silt. Head deposit.			
9508	Layer				Natural. Mid reddish brown sandy silt with gravels. Head deposit.			

Trench 96

General description						Orientation		E-W
Trench without archaeological features. Consists of ploughsoil overlying deposits of alluvium, a sterilization horizon and a leached horizon (Contained flints and burnt flint). Sondage excavated to 3m at E end.						Length (m)		30
						Width (m)		6
						Avg. depth (m)		0.68
Context No.	Type	Fill Of	Width (m)	Depth (m)	Description	Finds	Date	
9600	Layer			0.24	Ploughsoil. Dark greyish brown silty clay.			
9601	Layer			0.25	Alluvial Layer. Mid yellowish brown silty clay with grey mottling.			
9602	Layer			0.2	Other Layer. Light greyish yellow sandy silt. Leached horizon. Some worked flint and burnt flint.	Flint		
9603	Layer			0.14	Natural. Brick earth type deposits. Mid reddish brown sandy silt.			
9604	Layer			0.5	Natural. Brick earth type deposits. Light greyish brown clayey silt.			
9605	Layer			0.16	Natural. Brick earth type deposits. Firm mid greyish brown silty clay			
9606	Layer			0.54	Natural. Soft mid reddish brown Sandy clayey silt. Brick earth type deposits			
9607	Layer			0.18	Natural. Soft mid reddish yellow clayey silt with manganese mottling. Brick earth type deposits			
9608	Layer			0.3	Natural. Light brown sandy clay. Head Deposit.			
9609	Layer				Natural. Dark brown clay with yellow mottling. Bedrock			

Trench 97

General description						Orientation		NW-SE
---------------------	--	--	--	--	--	-------------	--	-------

Trench devoid of archaeology. Consists of ploughsoil, subsoil covering a sequence of various alluvial layers and banded organic alluvial. This is overlying a leached horizon. Below this are a mix of alluvial and colluvial layers. In the northern end of the trench a head deposit overlies a possible weathered deposit. Natural geology not reached at 2 meters depth. Sondage excavated to 3m at S. end.						Length (m)	30
						Width (m)	6
						Avg. depth (m)	2
Context No.	Type	Fill Of	Width (m)	Depth (m)	Description	Finds	Date
9700	Layer			0.2	Ploughsoil. Dark greyish brown silty clay.		
9701	Layer			0.3	Alluvial Layer. Mid greyish yellow clayey silt.		
9702	Layer			0.02	Buried soil. Dark grey clay, organic layer.		
9703	Layer			0.25	Alluvial Layer. light greyish mottled brownish yellow silty clay.		
9704	Layer			0.06	Alluvial Layer. Dark greyish brown silty clay		
9705	Layer			0.04	Alluvial Layer. Pale brown silty clay.		
9706	Layer			0.15	Alluvial Layer. Mid brownish yellow silt.		
9707	Layer			0.17	Alluvial Layer. Greyish brown humic rich clayey silt.		
9708	Layer			0.19	Alluvial Layer. Greyish brown organic rich clayey silt.		
9709	Layer			0.18	Colluvial Layer. Grey fine sandy silt with sand lenses		
9710	Layer			0.2	Colluvial Layer. Brown humic rich silt		
9711	Layer			0.27	Alluvial Layer. Greenish grey silt		
9712	Layer			0.2	Alluvial Layer. Brownish grey clayey silt		
9713	Layer			13	Colluvial Layer. Firm brown silt	Pot	IA?
9714	Layer			0.04	Colluvial Layer. Greyish brown slightly clayey silt		
9715	Layer			0.25	Colluvial Layer. Light brown "pinkish" silt		
9716	Layer			0.17	Colluvial Layer. Pale brown silty clay		
9717	Layer			0.18	Colluvial Layer. Light reddish brown silty clay		
9718	Layer			0.43	Natural. Stratified yellowish brown very firm clayey silt.		
9719	Layer			0.16	Natural. Strong brown silty sandy gravel		
9720	Layer			0.06	Natural. Greyish brown silty clay. WEATHERED BEDROCK		
9721	Layer			0.2	Alluvial Layer. Dark greyish brown silty clay		
9722	Layer			0.06	Alluvial Layer. Greyish brown silty clay		
9723	Layer			0.16	Other Layer. Stratified organic Alluvium		
9724	Layer			0.15	Alluvial Layer. Dark greyish brown humic rich silt		
9725	Layer			0.22	Alluvial Layer. Mid grey silty clay		
9726	Layer			0.2	Alluvial Layer. Grey slightly clayey silt (3m pit)		
9727	Layer			0.2	Alluvial Layer. Dark brown organic silt - 3m pit		
9728	Layer			0.2	Alluvial Layer. Brown to greenish grey clayey silt - 3m pit		

9729	Layer			0.2	Alluvial Layer. Dark greenish grey silty clay with frequent round wood 3m pit - not bottomed.		
------	-------	--	--	-----	---	--	--

Trench 98

General description					Orientation		NW-SE
Trench devoid of archaeology. Consists of ploughsoil and subsoil covering a sequence of various alluvial layers and fluvial sand. Geological ground not reached at 2 meters of depth. 3m sondage excavated at S. End.					Length (m)		30
					Width (m)		6
					Avg. depth (m)		2

Context No.	Type	Fill Of	Width (m)	Depth (m)	Description	Finds	Date
9800	Layer			0.3	Ploughsoil. Dark brownish grey silty clay.		
9801	Layer			0.16	Alluvial Layer. Dark grey silty clay with red mottling.		
9802	Layer			0.18	Alluvial Layer. Dark blackish grey silty clay, humic, with occasional charcoal.		
9803	Layer			0.06	Alluvial Layer. Dark brownish grey clay with red mottling. Humic. Occasional charcoal.		
9804	Layer			0.13	Buried soil. Mid grey clayey silt.		
9805	Layer			0.25	Alluvial Layer. Mid yellowish red clayey silt. Compact. Stoneless.		
9806	Layer			0.4	Alluvial Layer. Brown silt with band of small pebbles.		
9807	Layer			0.19	Alluvial Layer. Mid brown clayey silt.		
9808	Layer			0.27	Other Layer. Mid yellowish brown silty clay. Calcite inclusions.		
9809	Layer			0.07	Other Layer. Mid brown sand and small pebbles.		
9810	Layer			0.16	Buried soil. Dark grey with dark red mottling clayey silt.		
9811	Layer			0.21	Alluvial Layer. Grey clayey silt with brownish yellow mottling.		
9812	Layer			0.1	Other Layer. Mottled reddish brown sandy clay.		
9813	Layer			0.3	Alluvial Layer. Light bluish grey silty clay.		
9814	Layer			0.2	Other Layer. Mid brownish grey clayey sand.		
9815	Layer				Natural. Mid bluish brown clay with yellow mottling. London clay.		

Trench 99

General description					Orientation		NE-SW
Trench devoid of archaeology. Consists of ploughsoil overlying alluvial layers, gravel and London Clay bedrock. Sondage excavated to 3m at W end.					Length (m)		30
					Width (m)		6
					Avg. depth (m)		2

Context No.	Type	Fill Of	Width (m)	Depth (m)	Description	Finds	Date
9900	Layer			0.2	Ploughsoil. Dark brownish grey silty clay.		
9901	Layer			0.35	Alluvial Layer. Mid brownish grey clayey silt. Alluvium.		

9902	Layer			0.1	Alluvial Layer. Dark blackish grey clayey silt. Stabilisation horizon.		
9903	Layer			0.2	Alluvial Layer. Mid reddish brown clayey silt. Alluvium.		
9904	Layer			0.25	Alluvial Layer. Dark blackish brown organic silt? Peaty.		
9905	Layer			0.4	Alluvial Layer. Light greyish brown silty clay. Alluvium.		
9906	Layer			0.5	Alluvial Layer. Mid yellowish- reddish brown silty clay. Plant rooting. Alluvium?		
9907	Layer				Alluvial Layer. Mid green grey brown clayey silt. Alluvium.		
9908	Layer			0.25	Alluvial Layer. Dark grey silt clay with frequent organic material.		
9909	Layer			0.12	Alluvial Layer. Mid brown grey gravel of small sub-rounded pebbles <40mm with light brown silt clay and light brown yellow sand silt intermixed. Head deposit.		
9910	Layer			0.56	Natural. Dark brown silt clay with mid blue grey veins. Weathered London Clay bedrock.		
9911	Layer				Natural. Dark brown silt clay with mid blue grey veins. London Clay bedrock.		

Trench 100

General description		Orientation	E-W
Trench devoid of archaeology. Consists of ploughsoil covering a sequence of alluvial layers, including an organic soil in between. Geological layer not reached at 2 meters depth. 3m sondage excavated at E. end.		Length (m)	30
		Width (m)	6
		Avg. depth (m)	2

Context No.	Type	Fill Of	Width (m)	Depth (m)	Description	Finds	Date
10000	Layer			0.2	Ploughsoil. Dark greyish brown silty clay.		
10001	Layer			0.2	Subsoil. Light grey silty clay with light brown patches. SUBSOIL FROM ALLUVIUM.		
10002	Layer			0.3	Alluvial Layer. Light yellowish brown silty clay with red mottling.		
10003	Layer			0.05	Alluvial Layer. Mid reddish brown clay, with FE-mineralisation.		
10004	Layer			0.1	Buried soil. Dark brownish grey clayey silt, composing an organic soil. STABILISATION HORIZON.		
10005	Layer			0.15	Alluvial Layer. Light greyish brown silty clay.		
10006	Layer			0.15	Other Layer. Peat. Dark brown organic silt		
10007	Layer			0.4	Alluvial Layer. Brown to light brown organic rich silt.		
10008	Layer			0.1	Other Layer. Dark greyish brown organic silt (possible organic inclusions/leaves).		
10009	Layer			0.25	Alluvial Layer. Grey silty clay, homogenous.		

10010	Layer			0.2	Alluvial Layer. Light grey clayey silt. Waterlogged, rare charcoal. Not bottomed.		
10011	Layer			0.1	Alluvial Layer. Dark greyish blue silty clay.		
10012	Layer			0.4	Alluvial Layer. Mid greenish grey silty clay.		
10013	Layer				Natural. Mid bluish brown clay.		

Trench 101

General description					Orientation		E-W
Trench devoid of archaeology. Consists of ploughsoil overlying alluvial layers and possible stabilisation horizons.					Length (m)		30
					Width (m)		6
					Avg. depth (m)		2

Context No.	Type	Fill Of	Width (m)	Depth (m)	Description	Finds	Date
10100	Layer			0.16	Ploughsoil. Dark brownish grey clayey silt.		
10101	Layer			0.25	Alluvial Layer. Mid brownish grey with reddish brown mottling, clayey silt. Alluvium.		
10102	Layer			0.08	Alluvial Layer. Dark blackish grey clayey silt. Stabilisation horizon.		
10103	Layer			0.14	Alluvial Layer. Mid reddish brown clayey silt. Alluvium.		
10104	Layer			0.1	Alluvial Layer. Mid blackish brown organic rich silt? Peaty.		
10105	Layer			0.35	Alluvial Layer. Mid greyish brown clayey silt. Alluvium.		
10106	Layer			0.12	Alluvial Layer. Dark blackish brown slightly clayey silt. Organic rich silt? Peaty. Plant rooting present. Mottling-iron oxidisation?		
10107	Layer			0.26	Alluvial Layer. Mid grey silty clay. Alluvium.		
10108	Layer			0.2	Alluvial Layer. Mid blackish grey silty clay. Organic rich? Alluvium.		
10109	Layer			0.3	Alluvial Layer. Mid blueish grey silty clay. Mottling-iron oxidisation? Alluvium?		
10110	Layer				Natural. Mid reddish brown with blueish grey mottling. Silty clay. Iron oxidisation? Weathered bedrock?		

Trench 102

General description					Orientation		NW-SE
Trench devoid of archaeology, consisting of ploughsoil and subsoil covering a sequence of mineral and organic alluvial layers generated in waterlogged condition. Excavated to 2m. Sondage excavated to 3m at N. End.					Length (m)		30
					Width (m)		6
					Avg. depth (m)		2

Context No.	Type	Fill Of	Width (m)	Depth (m)	Description	Finds	Date
10200	Layer			0.3	Ploughsoil. Dark greyish brown silty clay.		
10201	Layer			0.18	Alluvial Layer. Mottled brownish yellow silty clay.		

10202	Layer			0.12	Alluvial Layer. Mottled pinkish grey clayey silt.		
10203	Layer			0.04	Buried soil. Dark greyish brown clayey silt with humic material.		
10204	Layer			0.14	Alluvial Layer. Mid reddish brown silty clay.		
10205	Layer			0.14	Other Layer. Dark reddish brown silty peat.		
10206	Layer			0.2	Other Layer. Dark reddish brown silty peat.		
10207	Layer			0.06	Alluvial Layer. Reddish black and pale brown banded clay.		
10208	Layer			0.16	Alluvial Layer. Light grey clay.		
10209	Layer			0.2	Other Layer. Dark reddish brown silty peat.		
10210	Layer			0.14	Alluvial Layer. Dark grey clayey silt with organic material.		
10211	Layer			0.64	Alluvial Layer. Mid grey silty clay with organic material.		
10212	Layer			0.32	Natural. Mid bluish grey silty clay.		
10213	Layer			0.26	Natural. Brownish grey silty clay.		
10214	Layer			0.1	Natural. Bedrock. Brownish grey silty clay with mid brown silty veins.		

Trench 103

General description	Orientation	NE-SW
Trench devoid of archaeology. Consists of ploughsoil and sequence of mineral and thin organic alluvial layers. Bedrock not reached at 2 meters depth. 3m sondage excavated at W. end.	Length (m)	30
	Width (m)	6
	Avg. depth (m)	2

Context No.	Type	Fill Of	Width (m)	Depth (m)	Description	Finds	Date
10300	Layer			0.2	Ploughsoil. Dark brownish grey silty clay.		
10301	Layer			0.3	Alluvial Layer. Brownish grey abundantly mottled yellowish brown clayey silt, Alluvium.		
10302	Layer			0.05	Alluvial Layer. Dark grey, blackish clayey silt, Stabilization horizon.		
10303	Layer			0.2	Alluvial Layer. Yellowish brown clayey silt, Alluvium.		
10304	Layer			0.1	Alluvial Layer. Dark brown organic silt, peaty. Stabilization horizon.		
10305	Layer			0.2	Alluvial Layer. Light greyish brown silty clay, Alluvium.		
10306	Layer			0.2	Alluvial Layer. Brown mottled yellowish red clayey silt with rooting and rare plant detritus. Stabilization horizon.		
10307	Layer			0.3	Alluvial Layer. Brownish grey clayey silt. Humic rich Alluvium.		
10308	Layer			0.5	Alluvial Layer. Grey clayey silt, not bottomed. Alluvium.		
10309	Layer			0.45	Alluvial Layer. Mid greenish grey silty clay.		
10310	Layer				Other Layer. Mid bluish brown clay with yellow mottling.		

Trench 104							
General description					Orientation		NW-SE
Trench devoid of archaeology. Consists of ploughsoil covering a sequence of alluvial layers, buried organic soil and two peat layers in between those. Geological ground not reached at 2 meters depth. Bedrock at 2.76m. Sondage excavated at N. end.					Length (m)		30
					Width (m)		6
					Avg. depth (m)		2
Context No.	Type	Fill Of	Width (m)	Depth (m)	Description	Finds	Date
10400	Layer			0.22	Ploughsoil. Dark greyish brown silty clay.		
10401	Layer			0.22	Alluvial Layer. Mid reddish yellow silty clay.		
10402	Layer			0.08	Buried soil. Dark greyish brown silty clay with humic element.		
10403	Layer			0.1	Alluvial Layer. Dark greyish yellow silty clay.		
10404	Layer			0.08	Other Layer. Dark greyish red oxidised slightly clayey silt. Mineralised Horizon.		
10405	Layer			0.06	Other Layer. Dark greyish brown silty peat.		
10406	Layer			0.1	Other Layer. Dark brown silty peat.		
10407	Layer			0.4	Alluvial Layer. Mid greyish brown clayey silt with a sandy element.		
10408	Layer			0.14	Other Layer. Mid grey sandy silt. Leached effluvium.		
10409	Layer			0.2	Natural. Mid brownish yellow silty clay. Head deposit.		
10410	Layer			0.8	Natural. Mid reddish brown silty clay with bluish veins.		
10411	Layer			0.36	Natural. Reddish brown silty clay with bluish grey veins weathered bedrock.		
10412	Layer				Natural. Mid greyish brown clay with bluish grey veins. Bedrock.		
10413	Layer			0.3	Alluvial Layer. Light brownish grey silty clay.		
Trench 105							
General description					Orientation		NE-SW
Trench devoid of archaeology. Consists of ploughsoil covering a sequence of alluvial layers and buried soil.					Length (m)		30
					Width (m)		1
					Avg. depth (m)		1.1
Context No.	Type	Fill Of	Width (m)	Depth (m)	Description	Finds	Date
10500	Layer			0.27	Ploughsoil. Dark brownish grey silty clay.		
10501	Layer			0.3	Alluvial Layer. Mid grey silty clay.		
10502	Layer			0.15	Alluvial Layer. Dark grey clay with yellow mottling.		
10503	Layer			0.2	Buried soil. Dark grey silty clay.		
10504	Layer			0.28	Alluvial Layer. Mid brown grey clayey silt.		
10505	Layer				Alluvial Layer. Light yellowish grey clay.		
Trench 106							

General description						Orientation		NW-SE
Trench revealed a big circular pit. Consists of ploughsoil and a subsoil, in the half of the trench towards SE covering a sequence of alluvial layers, then raising up on a natural bank where the pit has been created and where the artificial cut by the machine has been stopped. A ploughsoil over two alluvia one of which (10602) only appears on NW 2/3 of trench. These overlying three weathered head deposits. Excavated to a total depth of 2m. 3m sondage excavated to 3m at N. end.						Length (m)		30
						Width (m)		6
						Avg. depth (m)		0.72
Context No.	Type	Fill Of	Width (m)	Depth (m)	Description	Finds	Date	
10600	Layer			0.26	Ploughsoil. Dark greyish brown silty clay.			
10601	Layer			0.28	Alluvial Layer. Dark yellowish brown silty clay.			
10602	Layer			0.18	Other Layer. Light grey silty clay.			
10603	Cut		2.2	0.32	Pit			
10604	Fill	10603	2.2	0.32	Other Fill. Dark blackish brown clayey silt.			
10605	Layer			0.46	Natural. Stiff reddish brown silty clay.			
10606	Layer			0.34	Natural. Stiff mid reddish brown silty clay with common coarse calcite inclusion.			
10607	Layer				Natural. Stiff mid greyish brown silty clay with common bluish grey veins.			
Trench 107								
General description						Orientation		N-S
Trench without archaeological features. Consists of ploughsoil overlying alluvial and peat deposits (struck flint in organic alluvium). Excavated to a total depth of 2m. Sondage excavated at S. End to 3m.						Length (m)		30
						Width (m)		6
						Avg. depth (m)		2
Context No.	Type	Fill Of	Width (m)	Depth (m)	Description	Finds	Date	
10700	Layer			0.2	Ploughsoil. Mid greyish brown silty clay.			
10701	Layer			0.35	Alluvial Layer. Light yellowish grey silty clay. Mineral alluvial.			
10702	Layer			0.17	Alluvial Layer. Mid yellowish grey silty clay. Top 0.06m wavy stabilisation horizon of mid blackish grey silty clay. Mineral alluvium.			
10703	Layer			0.25	Alluvial Layer. Mid greyish brown clayey organic silt (peaty). Top 0.12m mid blackish brown organic silt lens.			
10704	Layer			0.04	Alluvial Layer. Mid brownish green silt. Mineral alluvium.			
10705	Layer			0.16	Alluvial Layer. Mid brown clayey silt. Humic. Alluvium.			
10706	Layer			0.22	Alluvial Layer. Mid brown clayey silt. Alluvium/ Reed swamp.			
10707	Layer			0.27	Alluvial Layer. Dark brown organic silt. Alluvium.	Flint		
10708	Layer			0.21	Alluvial Layer. Light to mid bluish grey clayey silt. Buried surface.			
10709	Layer			0.14	Alluvial Layer. Mid yellowish brown and mid greyish blue clayey silt. Alluvium.			
10710	Layer			0.15	Alluvial Layer. Light greenish grey silty clay.			

10711	Layer			0.35	Alluvial Layer. Mid greenish grey silty clay.		
10712	Layer			0.2	Alluvial Layer. Mid greenish brown silty clay.		
10713	Layer			0.15	Other Layer. Mid yellowish brown sandy clay.		
10714	Layer				Other Layer. Mid greyish brown clay with blue mottling.		

Trench 108

General description					Orientation		NW-SE
Trench devoid of archaeology. Consists of ploughsoil and subsoil overlying natural alluvial deposits similar to those in TR107 and TR109 Excavated to 2m. Sondage excavated to 3m at S. end. Not bottomed.					Length (m)		30
					Width (m)		6
					Avg. depth (m)		2

Context No.	Type	Fill Of	Width (m)	Depth (m)	Description	Finds	Date
10800	Layer			0.2	Ploughsoil. Dark grey brown, silty clay.		
10801	Layer			0.33	Alluvial Layer. Mid grey brown, silty clay.		
10802	Layer			0.22	Alluvial Layer. Mid brownish grey, silty clay. Mineral Alluvium with dark grey stabilization horizon in top part.		
10803	Layer			0.14	Alluvial Layer. Dark brown grey, clayey peat.		
10804	Layer			0.26	Alluvial Layer. Mid grey, silty clay, yellowish red Fe-mottling. Mineral Alluvium, assessed from GL.		
10805	Layer			0.25	Alluvial Layer. Brown organic rich clayey silt, assessed from GL.		
10806	Layer			0.05	Alluvial Layer. Dark greyish brown organic Alluvium, assessed from GL.		
10807	Layer			0.15	Alluvial Layer. Grey mineral Alluvium, assessed from GL.		
10808	Layer			0.05	Alluvial Layer. Dark greyish brown organic Alluvium.		
10809	Layer			0.35	Alluvial Layer. Grey mineral Alluvium, assessed from GL.		
10810	Layer			0.3	Alluvial Layer. Mid to dark grey fine grained deposit, possibility Alluvium, assessed from GL.		
10811	Layer			0.3	Alluvial Layer. Mid bluish grey silty clay.		
10812	Layer			0.3	Alluvial Layer. Mid blue grey silty clay with red mottling.		
10813	Layer				Alluvial Layer. Mid greenish brown silty clay with red mottling.		

Trench 109

General description					Orientation		NW-SE
Trench without archaeological features. Consists of ploughsoil and subsoil overlying alluvial deposits, buried soil and olive-brown silt with struck and burnt flint. Excavated to 2m. Slopes down to the north. Sondage excavated at S end. Bedrock at 1.5m.					Length (m)		30
					Width (m)		6
					Avg. depth (m)		2

Context No.	Type	Fill Of	Width (m)	Depth (m)	Description	Finds	Date
10900	Layer			0.24	Ploughsoil. Dark grey brown, silty clay.		

10901	Layer			0.27	Alluvial Layer. Mid brownish grey silt clay.		
10902	Layer			0.1	Buried soil. Dark grey, silty clay. Humic.		
10903	Layer			0.3	Alluvial Layer. Mid grey, red mottled, clay.		
10904	Layer				Buried soil. Dark grey humic silty clay.		
10905	Layer			0.15	Alluvial Layer. Mid yellowish grey clay.		
10906	Layer			0.6	Natural. Light grey brown, silty clay.		
10907	Layer			0.2	Alluvial Layer. Mid greyish brown silty clay with oxidised rooting.		
10908	Layer			0.8	Buried soil. Dark clayey silt with oxidised rooting. Buried or forming a soil.		
10909	Layer			0.36	Other Layer. Olive brown clay silt mottled with oxidised rooting and a mustard yellow following the oxidisation. Common Burnt flint and charcoal.	Flint	
10910	Layer			0.3	Natural. Mid greyish brown silty clay with oxidised rooting. Weathered London clay.		
10911	Layer				Natural. Mid greyish brown silty clay with calcium veins running vertical.		

Trench 110

General description						Orientation	N-S
Trench without archaeological features. Consists of ploughsoil, two alluvial layers (one with a struck flint), two leached horizons which were previous surfaces. Several head deposits of a clay and gravel. In between which is a possible Palaeolithic surface.						Length (m)	30
						Width (m)	6
						Avg. depth (m)	1.04
Context No.	Type	Fill Of	Width (m)	Depth (m)	Description	Finds	Date
11000	Layer			0.24	Ploughsoil. Dark grey brown, silty clay.		
11001	Layer			0.24	Alluvial Layer. Dark yellowish brown silty clay with common dark grey mottling and common manganese inclusions.		
11002	Layer			0.19	Alluvial Layer. Mid yellowish brown clayey silt with mid grey mottling.	Flint	
11003	Layer			0.7	Natural. Mid greyish brown silty clay with manganese and calcium inclusions.		
11004	Layer			0.14	Natural. Mid greyish brown silty clay with common calcium veins. head deposit.		
11005	Layer				Natural. Mid reddish brown silty gravel. Head deposit.		
11006	Layer			0.16	Alluvial Layer. Dark yellowish brown silty clay with common dark grey mottling.		
11007	Layer			0.16	Other Layer. Leached Horizon. Soft pale yellowish grey with mid reddish yellow mottling. Former surface. Possibly a different (11002).		
11008	Layer			0.24	Other Layer. Light brownish grey slightly silty clay with oxidise red mottling.		

11009	Layer			0.3	Natural. Mid greyish brown silty clay with red oxidised veins. Head deposit.		
11010	Layer			0.08	Other Layer. Light reddish brown silty clay. Possible Palaeolithic surface.		

Trench 111

General description	Orientation	NEE-SWW
Trench without archaeological features. Consists of ploughsoil overlying natural alluvial deposits interspersed with 2-3 buried soils/peat layers. Excavated to a total depth of 2m.	Length (m)	30
	Width (m)	6
	Avg. depth (m)	2

Context No.	Type	Fill Of	Width (m)	Depth (m)	Description	Finds	Date
11100	Layer			0.2	Ploughsoil. Dark greyish brown silty clay.		
11101	Layer			0.16	Alluvial Layer. Mid yellowish brown silty clay.		
11102	Layer			0.18	Alluvial Layer. Mid Mottled greyish brown clayey silt with oxidising.		
11103	Layer			0.28	Alluvial Layer. Dark greenish grey clay with common flint fragments.		
11104	Layer			0.06	Buried soil. Dark grey silt clay with dark reddish yellow mottling and charcoal and humic inclusions.		
11105	Layer			0.3	Alluvial Layer. Bluish grey clayey silt with reddish mottling.		
11106	Layer			0.1	Alluvial Layer. Mid greyish brown silty clay.		
11107	Layer			0.24	Alluvial Layer. Pinkish grey silty sand.		
11108	Layer			0.25	Alluvial Layer. Mid brownish grey slightly clayey silt.		
11109	Layer			0.1	Other Layer. Mid greyish brown clayey silt possibly organic.		
11110	Layer			0.44	Alluvial Layer. Dark brownish grey silty clay. Humic.		
11111	Layer			0.25	Alluvial Layer. Dark brownish grey clayey silt with oxidising.		
11112	Layer			0.35	Natural. Dark olive grey silty clay with oxidised rooting.		
11113	Layer			0.18	Other Layer. Dark olive grey sandy silt possible peat.		
11114	Layer			0.16	Alluvial Layer. Light -mid grey silty clay with common flint inclusions.		
11115	Layer			0.2	Natural. Mid bluish brown clay with no inclusions. Head deposit/weathered bedrock.		
11116	Layer				Natural. Bluish brown clay with light grey veins. London clay.		

Trench 112

General description	Orientation	NW-SE
Trench devoid of archaeology. Consists of ploughsoil overlying a series of mineral and alluvial deposits, with frequent plant remains between 1.70 to 3m depth, not bottomed at southern end. At the northern end a Pleistocene Brick Earth Type Deposit occurs at 1.5m BGL below a grey	Length (m)	30
	Width (m)	6
	Avg. depth (m)	2

leached horizon. Excavated to a total depth of 2m. Sondage excavated to 3 at S end.							
Context No.	Type	Fill Of	Width (m)	Depth (m)	Description	Finds	Date
11200	Layer			0.1	Ploughsoil. Dark grey brown silty clay.		
11201	Layer			0.3	Alluvial Layer. Yellowish brown oxidized clayey silt, Alluvium.		
11202	Layer			0.2	Alluvial Layer. Yellowish brown oxidized clayey silt, dark grey at top 70mm, Alluvium with Stabilization horizon.		
11203	Layer			0.05	Alluvial Layer. Dark greyish brown layer of organic Alluvium.		
11204	Layer			0.35	Alluvial Layer. Light brown organic rich silty clay, with lens (0.2) of brown organic silt (11205) at top in northern part.		
11205	Layer			0.2	Alluvial Layer. Brown organic silt, Organic Alluvium, only present in northern part of trench.		
11206	Layer			0.25	Alluvial Layer. Light greyish brown clayey silt, Humic Rich Alluvium.		
11207	Layer			0.15	Alluvial Layer. Greyish brown organic rich clayey silt, Organic Rich Alluvium.		
11208	Layer			0.6	Alluvial Layer. Light greenish grey clayey silt, Alluvium, not bottomed.		
11209	Layer			0.2	Other Layer. Light grey clayey silt, Leached Horizon.		
11210	Layer			0.5	Natural. Yellowish brown clayey silt. Head Deposits		
11211	Layer			0.45	Alluvial Layer. Stratified bands of brown organic Alluvium and bluish grey mineral Alluvium.		
11212	Layer			0.45	Alluvial Layer. Greenish grey Alluvium with common small plant detritus (10%)		
11213	Layer			0.3	Alluvial Layer. Soft dark greyish brown organic rich silt, frequent plant remains (25%).		
11214	Layer			0.25	Alluvial Layer. soft light bluish grey silty clay with common plant detritus (10-20%)		
11215	Layer			0.05	Alluvial Layer. Greyish brown clayey organic rich silt, frequent plant remains		
Trench 113							
General description					Orientation		ENE-WSW
Trench devoid of archaeology. Consists of ploughsoil overlying natural alluvial deposits over the natural geology of clay and gravel. Also contains a buried soil and an effluvial layer. Excavated to a total depth of 2m.					Length (m)		30
					Width (m)		6
					Avg. depth (m)		1.88
Context No.	Type	Fill Of	Width (m)	Depth (m)	Description	Finds	Date
11300	Layer			0.2	Ploughsoil. Dark greyish brown silty clay.		
11301	Layer			0.24	Alluvial Layer. Mid reddish yellow silty clay.		

11302	Layer			0.24	Other Layer. Mottled mid reddish grey silty sand.		
11303	Layer			0.06	Natural. Dark reddish brown silty clay with abundant gravel.		
11304	Layer			0.06	Buried soil. Dark brown clayey silt.		
11305	Layer			0.42	Alluvial Layer. Mottled dark reddish yellow clayey silt.		
11306	Layer			0.34	Alluvial Layer. Oxidised reddish grey silty clay.		
11307	Layer			0.16	Alluvial Layer. Oxidised mid reddish grey clay silt.		
11308	Layer			0.16	Alluvial Layer. Mid greyish brown slightly clayey silt.		
11309	Layer			0.22	Alluvial Layer. Oxidised mid brownish grey clayey silt.		
11310	Layer			0.16	Alluvial Layer. Brown silty clay.		
11311	Layer			0.24	Alluvial Layer. Brown slightly clayey silt.		
11312	Layer			0.48	Natural. Dark reddish brown silty clay.		
11313	Layer				Natural. Mid greyish brown clay with bluish grey veins.		
11314	Layer			0.06	Natural. Reddish brown silty clay with abundant gravel.		

Trench 114

General description					Orientation		NNW-SSE
Trench devoid of archaeology. Consists of ploughsoil, subsoil and proto soil overlying natural alluvial and an effluvial Sandy deposits over the natural geology of weathered clay and head deposit gravel. Excavated to a total depth of 2m.					Length (m)		30
					Width (m)		6
					Avg. depth (m)		1.5
Context No.	Type	Fill Of	Width (m)	Depth (m)	Description	Finds	Date
11400	Layer			0.25	Ploughsoil. Dark greyish brown silty clay.		
11401	Layer			0.24	Subsoil. Mid yellowish brown silty clay.		
11402	Layer			0.18	Alluvial Layer. Mid mottled greyish yellow silty clay.		
11403	Layer			0.1	Natural. Dark reddish brown silty gravel head deposit.		
11404	Layer			0.22	Buried soil. Mid reddish brown silty clay mottled with dark greyish brown. Proto or buried soil.		
11405	Layer			0.18	Alluvial Layer. Mid greyish yellow silty clay mottled with a dark reddish yellow.		
11406	Layer			0.19	Alluvial Layer. Light yellow grey silty sand with dark reddish yellow mottling.		
11407	Layer			0.43	Alluvial Layer. Light grey yellow silty clay with dark reddish brown mottling.		
11408	Layer			0.15	Natural. Brick earth. Mid reddish brown silt.		
11409	Layer				Natural. Weathered London clay mid grey brown silty clay.		

Trench 115

General description					Orientation		E-W
---------------------	--	--	--	--	-------------	--	-----

Trench devoid of archaeology. Consists of ploughsoil and subsoil overlying a leached horizon, several alluvial layers and a brick earth deposit on top of London Clay.						Length (m)		30
						Width (m)		6
						Avg. depth (m)		1.2
Context No.	Type	Fill Of	Width (m)	Depth (m)	Description	Finds	Date	
11500	Layer			0.18	Ploughsoil. Dark grey brown, silty clay.			
11501	Layer			0.25	Alluvial Layer. Dark brownish grey silty clay.			
11502	Layer			0.18	Alluvial Layer. Light yellow grey clayey silt. Leached horizon.			
11503	Layer			0.1	Alluvial Layer. Light reddish brown silty clay.			
11504	Layer			0.11	Alluvial Layer. Mid reddish brown silty clay with common manganese.			
11505	Layer			0.38	Alluvial Layer. Light grey brown silty clay with red and grey mottling.			
11506	Layer			0.1	Natural. Brick Earth. Mid reddish yellow slightly clayey silt.			
11507	Layer			0.54	Natural. Mid grey brown silt clay with calcium veins. London Clay.			

Trench 116

General description						Orientation		NNW-SSE
Trench devoid of archaeology. Consists of ploughsoil and subsoil overlying natural leached and oxidised alluvial deposits. Sandy fluvial layers lay beneath the alluvial with a gravelly head deposit and weathered bedrock beneath that.						Length (m)		30
						Width (m)		2
						Avg. depth (m)		0.53
Context No.	Type	Fill Of	Width (m)	Depth (m)	Description	Finds	Date	
11600	Layer			0.2	Ploughsoil. Mid greyish brown clay silt.			
11601	Layer			0.06	Alluvial Layer. Light bluish grey clayey silt with light yellowish red lenses.			
11602	Layer			0.27	Alluvial Layer. Light bluish grey sandy silt with brownish red streaks.			
11603	Layer				Natural. Light red sandy silt with bluish grey lenses.			
11604	Layer			0.2	Other Layer. Mid reddish brown sandy gravel.			
11605	Layer				Natural. Dark greyish brown silty clay.			
11606	Layer			0.22	Alluvial Layer. Dark brownish grey silty clay with brownish yellow lenses.			
11607	Layer			0.12	Natural. Mid reddish yellow clayey sand with dark grey mottling.			
11608	Layer			0.04	Natural. Mid reddish grey Sandy clay.			
11609	Layer			0.4	Natural. Weathered London clay. Reddish grey silty clay with calcium and oxidised iron inclusions.			

Trench 117

General description						Orientation		NNW-SSE
						Length (m)		30
						Width (m)		6

Trench devoid of archaeology. Consists of ploughsoil and subsoil overlying greyed and weathered horizons that overlie a gravelly head deposit. This overlies London Clay.						Avg. depth (m)	0.46
Context No.	Type	Fill Of	Width (m)	Depth (m)	Description	Finds	Date
11700	Layer		6	0.2	Ploughsoil. Dark greyish brown silty clay.		
11701	Layer		6	0.16	Subsoil. Mid yellowish brown silty clay.		
11702	Layer		6	0.1	Subsoil. Mixed light greyish brown clayey silt with light yellowish brown mottling.		
11703	Layer		6	0.17	Other Layer. Light blueish grey fine sandy silt. Greyed/ leached horizon possibly as a result of pedogenesis.		
11704	Layer		1	0.26	Other Layer. Mid yellowish brown clay silt. Mod frequent bluish grey patches. Possible weathered horizon due to pedogenesis or brickearth-type head deposit.		
11705	Layer				Natural. Dark yellowish brown, clayey silt gravel. Frequent pebbles. Head deposit.		
11706	Layer			0.2	Natural. Compact, reddish brown silty clay. Cryoturbated and weathered London Clay bedrock.		
11707	Layer				Natural. Compact, strong reddish brown silty clay. London Clay bedrock.		

Trench 118

General description						Orientation	WNW-ESE
Trench devoid of archaeology. Consists of ploughsoil, a colluvium overlying a proto soil, a leached horizon, weathered London clay with gravel bands and then banded London grey clay.						Length (m)	30
						Width (m)	6
						Avg. depth (m)	0.7

Context No.	Type	Fill Of	Width (m)	Depth (m)	Description	Finds	Date
11800	Layer			0.22	Ploughsoil. Dark greyish brown silty clay.		
11801	Layer			0.12	Colluvial Layer. Mid reddish brown silty clay.		
11802	Layer			0.2	Buried soil. Mottled Mid greyish brown silty clay.		
11803	Layer			0.16	Natural. Light grey silty clay mottled with lift reddish yellow silty clay.		
11804	Layer			0.34	Natural. Mid red brown with bands of small sub-round pebbles.		
11805	Layer			0.4	Natural. London Clay. Md grey brown slightly silty clay.		
11806	Layer			0.06	Natural. Mid reddish yellow silty clay.		
11807	Layer			0.5	Natural. London Clay. Mid grey brown silty clay with calcium inclusions.		

Trench 119

General description						Orientation	E-W
						Length (m)	30

Trench devoid of archaeology. Consists of ploughsoil and subsoil overlying natural alluvial deposits over the natural geology of clay and gravel.					Width (m)	2	
					Avg. depth (m)	0.7	
Context No.	Type	Fill Of	Width (m)	Depth (m)	Description	Finds	Date
11900	Layer			0.2	Ploughsoil. Dark greyish brown silty clay.		
11901	Layer			0.15	Subsoil. Mid yellowish brown silty clay.		
11902	Layer			0.35	Alluvial Layer. Light mottled greyish brown sandy clay.		
11903	Layer				Natural. Dark reddish brown clay with gravel patches.		
11904	Cut				Natural Feature. Natural pit, possibly water pooling. Fill is greyish orange soft silty clay.		

Trench 120

General description					Orientation	NE-SW	
Trench devoid of archaeology. Consists of ploughsoil and subsoil overlying a layer of weathered clay and gravel.					Length (m)	30	
					Width (m)	2	
					Avg. depth (m)	0.5	
Context No.	Type	Fill Of	Width (m)	Depth (m)	Description	Finds	Date
12000	Layer			0.2	Ploughsoil. Dark greyish brown silty clay.		
12001	Layer			0.3	Subsoil. Mid reddish grey silty clay.	Flint	
12002	Layer				Natural. Mid reddish brown clay with gravel patches.		
12003	Cut		0.56	0.37	Tree Throw. Natural feature. Dark grey silty clay.		

Trench 279

General description					Orientation	NW-SE	
Trench devoid of archaeology. Consists of ploughsoil overlying alluvium, leached horizon, head deposit, weathered bedrock and bedrock.					Length (m)	30	
					Width (m)	6	
					Avg. depth (m)	0.97	
Context No.	Type	Fill Of	Width (m)	Depth (m)	Description	Finds	Date
27900	Layer			0.2	Ploughsoil. Dark blackish grey. clayey silt.		
27901	Layer			0.06	Alluvial Layer. Mid reddish brown clayey silt.		
27902	Layer			0.05	Other Layer. Dark blackish grey slightly clayey silt. Peaty. Organic rich silt?		
27903	Layer			0.25	Alluvial Layer. Dark grey clayey silt.		
27904	Layer			0.2	Other Layer. Dark blackish grey slightly clayey silt. Peaty. Organic rich silt?		
27905	Layer			0.21	Alluvial Layer. Mid grey silt.		
27906	Layer			0.12	Other Layer. Light grey silt, trace of clay. Leached horizon.		

27907	Layer			0.24	Other Layer. Mid grey silty clay. Head deposit?		
27908	Layer			0.17	Natural. Mid reddish brown clayey silt. Weathered bedrock.		
27909	Layer			0.45	Natural. Mid brown silty clay. Weathered bedrock.		
27910	Layer				Natural. Mid brown silty clay. Mid blueish grey veins. Bedrock.		

Trench 280

General description						Orientation	E-W
Trench devoid of archaeology. Consists of ploughsoil overlying sequence of Alluvium over stabilisation horizon. This seals a further 5 alluvial layers with a very organic alluvium in the middle. Under this is two weathered bedrock contexts. Excavated to a max depth of 2m.						Length (m)	30
						Width (m)	6
						Avg. depth (m)	1.55
Context No.	Type	Fill Of	Width (m)	Depth (m)	Description	Finds	Date
28000	Layer			0.23	Ploughsoil. Mid greyish brown silty clay		
28001	Layer			0.25	Alluvial Layer. Mid yellowish brown mottled by mid greyish brown. Slightly silty clay		
28002	Layer			0.04	Other Layer. Stabilisation horizon Dark black mottled by dark strong brown. Clayey silt		
28003	Layer			0.18	Alluvial Layer. Mid greyish brown mottled with mid reddish brown, clayey silt		
28004	Layer			0.1	Alluvial Layer. Organic alluvium Banded dark brown and mid greyish brown. Slightly clayey silt		
28005	Layer			0.04	Alluvial Layer. Mid greyish brown slightly silty clay, humic		
28006	Layer			0.57	Alluvial Layer. Pale greyish brown mottled by dark greyish brown with darker brown predominant at upper boundary. Silty clay		
28007	Layer			0.12	Alluvial Layer. Mid greyish brown mottled by mid reddish brown, silty clay		
28008	Layer			0.28	Natural. Darker bluish grey mottled with black specs (degraded roots)		
28009	Layer			0.24	Natural. Mid bluish grey mottled by light yellow. Slightly silty clay		

Trench 281

General description						Orientation	N-S
						Length (m)	30

Trench contains ploughsoil overlying an alluvium sealing a stabilisation horizon. Underlying this 5 alluvial layers varying in organic content, one with struck flints. With most organic alluvium 0.70-085m depth. Underlying this alluvial sequence, a thin leached horizon on top of a weathered bedrock.					Width (m)	6	
					Avg. depth (m)	1.24	
Context No.	Type	Fill Of	Width (m)	Depth (m)	Description	Finds	Date
28100	Layer			0.22	Ploughsoil. Dark greyish brown silty clay		
28101	Layer			0.24	Alluvial Layer. Mid greyish brown mottled by mid yellowish brown. Clayey silt		
28102	Layer			0.03	Other Layer. Stabilisation horizon Dark greyish brown mottled with mid yellowish brown. Clayey silt		
28103	Layer			0.21	Alluvial Layer. Pale greyish brown mottled by mid yellowish brown. Clayey silt	Flint	
28104	Layer			0.15	Alluvial Layer. Organic alluvium Mid greyish brown banded by dark brown. Clayey silt.		
28105	Layer			0.04	Alluvial Layer. Mid greyish brown silty clay		
28106	Layer			0.28	Alluvial Layer. Pale greyish brown mottled with darker greyish brown (dominant in upper part of context) silty clay		
28107	Layer			0.07	Alluvial Layer. Mid grey slightly silty clay		
28108	Layer			0.04	Other Layer. Pale brown (greyish?) Slightly clayey silt		
28109	Layer			0.02	Natural. Mid greyish brown mottled by a mid-yellowish brown, silty clay.		

B.1 Prehistoric Pottery

By Alex Davies

Introduction

B.1.1 All of the pottery recovered from this evaluation was prehistoric. This totals 27 sherds weighting 231g from 7 trenches.

B.1.2 Most of the material is from Trench 86, and this is early Neolithic. The rest might all be Iron Age, although a later Bronze Age date is possible for some of the sherds.

Methodology

B.1.3 Pottery from each context was scanned with spot-dates given based on the latest material present. Fabrics were recorded in order of their approximate frequency in any one context. The two most common inclusion types were noted, using the following fabric codes:

- Fl Flint
- Qs Quartz sand

B.1.4 The grade of the fabric was also recorded with a number suffix, ranging from 1 (fine) to 4 (very coarse).

B.1.5 Context 8603 was a flint scatter, and each sherd was individually recovered and its location recorded. Given this different recovery method, the pottery was recorded in more detail. This is described below.

B.1.6 All the data that was recorded is presented in Tables 1-2. There is no additional data or metadata.

Early Neolithic from Trench 86

B.1.7 The majority of the pottery from the site came from flint scatter context 8603, and all of the pottery from Trench 86 was from context 8603. Each sherd has an individual find number and its location recorded exactly, except three sherds recorded in 'Grid AAA' that were cleaned from the section and were not attributed to a SF number. The pottery from context 8603 totals 17 sherds and weighs 205g. The pottery probably belongs to the early Neolithic Plain Bowl tradition.

B.1.8 The sherds were laid out, then grouped together into those that probably belong to the same vessel. Approximately six vessels were present, shown on Table 1.

B.1.9 Vessel 1 comprises 7 sherds (63g). The fabric contains poorly sorted coarse and very coarse flint inclusions, and quartz sand. A rim sherd is plain and slightly incurving, showing the vessel is ovoid. It is too small to accurately measure diameter.

B.1.10 Vessel 2 is a single very abraded 1g sherd in a medium flint fabric, find number 167.

B.1.11 Vessel 3 is a single 9g sherd in a well-sorted medium flint fabric, find number 431. It could be later prehistoric in date, although early Neolithic is likely given the context.

- B.1.12 Vessel 4 comprises three sherds (4g) in a medium sandy fabric. No flint is present, although the sherds are very small and abraded and might simply be small pieces that had fractured around flint inclusions.
- B.1.13 Vessel 5 is composed of 4 sherds (121g). The largest sherd, find number 211, is a pinched lug weighing 106g with a diameter of c 32cm. Two other sherds are part of the lug. The vessel has coarse flint inclusion that are moderately well sorted.
- B.1.14 Vessel 6 might be the same as vessel 3. It is a single sherd (6g, find number 157) in a medium flint fabric that could date to the later prehistoric period, although early Neolithic is likely given the context.

The rest of the assemblage

- B.1.15 Excluding the material in Trench 86, the rest of the pottery is very small, fragmentary and abraded undiagnostic body sherds. Dating this group is problematic, especially as flint was used in the region as temper for most of the prehistoric period. For example, at Mucking, 5km to the south-east of the site, flint dominated the earlier Neolithic and late Bronze Age to middle Iron Age pottery (Barrett 1988; Brown 2016; Brudenell 2016a; 2016b; Kinnes and Birley 2016). Sand was increasingly popular though the Iron Age, only becoming dominant around the second century BC. The poorly-sorted nature of flint in the fabric of most of the early Neolithic pottery from Trench 86 and elsewhere on the LTC sites, with flint pieces of greatly varying in size and distribution within sherds, distinguishes the material from the later prehistoric pottery, although this is not a very reliable means for dating, especially with small sherds.
- B.1.16 The sherd from 2202 has a very broad spot-date of the early Neolithic and middle Bronze Age-middle Iron Age. Sherds in contexts 6902, 9002 and an unstratified sherd are probably middle Bronze Age-middle Iron Age, and the predominantly sandy sherds in contexts 6006 and 9713 are probably Iron Age. The small size of the context groups means that dating the features based on the associated pottery is problematic as some or all of the material might be residual or intrusive.

Find no.	Count	Weight (g)	Fabric	Comment	Vessel
Grid AAA (no SF)	1	13	FIQs3-4 poorly sorted		1
Grid AAA (no SF)	1	13			1
Grid AAA (no SF)	1	12		Plain rim from slightly ovoid vessel	1
Grid AAA (no SF)	1	6			1
297 (Grid AAA)	1	10			1
296 (Grid AAA)	1	4			1
158	1	5			1
167	1	1	FI2?	Very abraded	2
431 (Grid AAA)	1	9	FI2 well sorted	Could be later prehistoric	3
160	1	1	Qs2	Very small and abraded	4
161	1	1			4
164	1	3		Very small and abraded	4

Find no.	Count	Weight (g)	Fabric	Comment	Vessel
170	1	5	FI3 moderately sorted	Possible lug frag, like 211	5
211 (Grid AAA)	1	106		Pinched lug, c 32 cm diameter	5
172	1	2			5
210 (Grid AAA)	1	8		Lug frag	5
157	1	6	FI2	Could be later prehistoric	6
	17	205			

Table 1: Pottery from context 8603

Context	Count	Weight (g)	Fabric	Spot-date	Comment
2202	1	5	FI3	E Neo or MBA-MIA	Abraded flint-tempered sherd. Not clearly like most of poorly sorted flint tempers of E Neo, nor well sorted later prehistoric at the site
6006	3	5	QsFI1	IA	Burnished
6902	1	10	FI2	MBA-MIA	
9002	2	2	FI2	MBA-MIA	Small and abraded
9713	2	3	QsFI2	IA?	
Unstratified	1	1	FI2	MBA-MIA	OCAWS403, 0.77m bpgl
	10	26			

Table 2: Summary of remaining pottery assemblage by context

B.2 Flint

By Lawrence Billington

Introduction

- B.2.1 A large assemblage of 1580 worked flints and 814g (119 fragments) of unworked burnt flint was recovered during the trial trenching. A very large proportion of the flint, 1314 worked flints, making up 80 per cent of the entire assemblage, derived from a dense lithic scatter from layers exposed in Trench 86 (scatter 8603). This assemblage appears to represent a minimally disturbed, essentially single period assemblage of late Mesolithic date. Much smaller assemblages of flintwork, including a Mesolithic/earlier Neolithic blade-based component but also including simple flake-based material of late Neolithic to later Bronze Age/Iron Age date, were recovered from topsoil, subsoil, and alluvial deposits across the evaluated area, although there was an almost complete dearth of lithic material from cut features.
- B.2.2 This report provides a brief overview and characterisation of the assemblage, beginning with some general comments on the raw material and condition of the assemblage as a whole, followed by a description of the flint from Trench 86 and then the material from other trenches/contexts. The report is concluded by a general discussion. A basic quantification of the assemblage is provided in Table 3, which provides a separate breakdown for the large assemblage of material from Trench 86. A summary catalogue of the flint by the context is provided at the end of this report as Table 7.

Methodology

- B.2.3 The assemblage was catalogued directly onto an Excel spreadsheet and the artefacts were classified according to a system of broad artefact/debitage types based on standard definitions for post-glacial lithic assemblages from southern Britain (e.g. Bamford 1985, 72-77; Healy 1988, 48-9; Butler 2005; Ballin 2021). Additional information on selected non-metric attributes of the material (including extent of dorsal cortex coverage, breakage and condition) was also recorded using standard classifications and terminology, alongside free text notes where appropriate. No detailed technological or metric analysis have been undertaken at this stage, nor has any concerted attempt at refitting or matching of raw material units been attempted. A full copy of the resulting catalogue is retained in the project archive.

Type	Trench 86	Other	Total
Chip	461	15	476
Irregular waste	19	18	37
Flake	466	184	650
Blade	142	24	166
Bladelet	164	7	171
Blade-like flake	22	4	26
Core tablet	2		2
Crested removal	4	1	5
Axe/adze sharpening flake	1		1
Microburin	3		3
Scraper	1		1

Type	Trench 86	Other	Total
Piercer		1	1
Microlith	15		15
Misc. retouched	2	1	3
Denticulate		1	1
Bifacially worked implement	1		1
Edge trimmed blade	1		1
Single platform flake core		2	2
Multiple platform flake core		1	1
Single platform blade/let core	3		3
Multiple platform blade/let core		2	2
Opposed platform core	5	1	6
Discoidal core	1		1
Retouched core	1		1
Minimally worked core		4	4
Total worked flint	1314	266	1580
Unworked burnt flint count	62	57	119
Unworked burnt flint wt. (g)	318.9	494.6	813.5

Table 3: Basic quantification of the flint assemblage

Raw materials and condition

- B.2.4 The entire assemblage is made up of flint. There is considerable variability in the character of surviving cortical surfaces and in the colour and texture of the flint, suggesting the use of a variety of sources, but there was very little material with the kind of fresh unweathered cortex which would suggest procurement direct from the parent chalk. Pieces with the rounded, heavily cortical surfaces typical of cobbles collected from fluvial gravels were most common, but pieces struck from nodular pieces, often with thermally fractured surfaces, were also present. Bullhead flint – identifiable on the basis of its green/grey cortex with underlying orange band - was a minor, but persistent feature of the assemblage, with 45 pieces identified (4% of the assemblage excluding chips). Sources of the kind of flint represented in the assemblage would have been available relatively locally, probably including the gravels and head deposits that flank and underly the valley of the Mar Dyke, whilst the contact between the Thanet sands and the chalk where the Bullhead flint originates is located some 3km south of the site.
- B.2.5 The large assemblage recovered from scatter 8603 (Trench 86) was largely in very good condition, with only occasional edge damage consistent with trampling or minor disturbance and in many cases individual pieces could be described as fresh. Much of the material from the other trenches, especially from subsoil, ‘natural’ and alluvial deposits was also in good condition, whilst the small quantities of flint collected from topsoil deposits and as unstratified material was invariably in much poorer condition, with frequent edge damage and abrasion/rounding.
- B.2.6 Cortication (‘patination’) was present on minority of the worked flint (132 pieces; 8.4%), and was invariably very light – generally taking the form of a light blue sheen/clouding. Differential cortication occurred in the large assemblage from scatter 8603, between pieces from otherwise indistinguishable in terms of depositional

context, condition and technology, and at this stage of analysis it does not appear to have any clear chronological significance.

Trench 86

- B.2.7 The large assemblage of worked flint from Trench 86 (Table 3) was almost exclusively assigned to scatter 8603, with only two flakes coming from the ploughsoil (8600) and three flakes and a blade coming from layer 8605. The worked flint from scatter 8603 included 49 pieces collected as surface finds: these were thinly distributed along the length of the trench, with a denser concentration at its western end. A single 1x1m test pit, AAA, excavated here, in the western end of the trench, produced the vast majority of the flint from the scatter, a total of 1254 worked flints. Excavation of a second 1x1m test pit in the eastern part of the trench (ADD), however, yielded only a very small collection of five worked flints.
- B.2.8 The assemblage from Test Pit AAA is quantified in Table 4, broken down by spit (50mm thick vertical excavation units). Recovery from this test pit was largely by hand recovery (1053 pieces), with wet sieving of a series of bulk samples taken from each of the spits producing a further 201 pieces; the latter was overwhelmingly dominated by small pieces, including 123 chips (<10mm). The majority of the flintwork was recovered from spits 2-7 (0.05-0.35m), with a clear fall off in the density of flint from spit 8 (0.35-0.4m) onwards.
- B.2.9 Despite the large size and very high density of the assemblage from Test Pit AAA, it is remarkably coherent in terms of its condition, technological traits/signature and composition. As noted above, in general terms the assemblage is in very good condition, consistent with having seen minimal post-depositional disturbance, although minor edge damage and breaking consistent with some trampling etc. is fairly common and almost 18% of the worked flint displays traces of heating/burning, probably where material has been caught up in hearths/ fire settings.
- B.2.10 The vast bulk of the assemblage very clearly belongs to a Mesolithic blade/bladelet-based industry; the blade index of the assemblage is very high, with blades and bladelets accounting for 39% of all unretouched removals from Test Pit AAA. Small numbers of specialised core rejuvenation and maintenance removals are also present (core tablets and partly crested blades/flakes). The majority of the nine cores recovered are heavily exploited blade/bladelet cores, including four opposed platform cores and three with single platforms. The core to flake ratio (84:1) and percentages of wholly cortical and partly cortical unretouched removals (1.6% and 30.4% respectively) are closely comparable with those from experimentally produced assemblages utilising similar blade/let technologies on pebble flint (Mithen *et al.* 2000) and suggests that the assemblage derive from all stages of core reduction, from the initial preparation of raw material through to the discard of exhausted cores. Tool manufacture is also represented by three proximal micro-burins and a single axe/adze sharpening flake, all from Test Pit AAA.

Type	Spit											
	1	2	3	4	5	6	7	8	9	10	Other	Totals
Chip	16	55	136	72	64	52	51	6	3	2		457
Irregular waste	1	2	6	2	3				1		1	16
Flake	26	60	95	59	35	57	38	13	14	11	21	429
Blade	8	16	18	20	12	24	16	7	1	1	10	133
Bladelet	12	21	44	22	16	19	12	8	1	1	5	161
Blade-like flake	1	1	4	4	5	3	1				2	21
Core tablet			1						1			2
Crested removal				2		1	1					4
Axe/adze sharpening flake											1	1
Microburin				1		1	1					3
Microlith	2	3	2	4	1	2		1				15
Misc. retouched		1					1					2
Edge trimmed blade						1						1
Single platform blade/let core			1		1						1	3
Opposed platform core		1	1								2	4
Discoidal core											1	1
Retouched core						1						1
Totals	66	160	308	186	137	161	121	35	21	15	44	1254
<i>Burnt and worked %</i>	<i>12.1</i>	<i>11.3</i>	<i>15.3</i>	<i>19.4</i>	<i>21.2</i>	<i>23.0</i>	<i>30.6</i>	<i>11.4</i>	<i>14.3</i>	<i>6.7</i>	<i>9.1</i>	<i>17.9</i>
<i>From samples (sieved) count</i>	<i>20</i>	<i>42</i>	<i>130</i>	<i>-</i>	<i>4</i>	<i>-</i>	<i>-</i>	<i>5</i>	<i>-</i>	<i>-</i>	<i>-</i>	<i>201</i>

Table 4: Worked flint from Test Pit AAA, scatter 8603

- B.2.11 The retouched component of the scatter was extremely restricted. Twenty retouched tools were recovered, of which 18 came from Test Pit AAA. They are dominated by microliths (15), alongside a small number of pieces with simple edge retouch. The only scraper recovered from the scatter was a broken fragment which was collected as a surface find (SF 303), as was an unusual bifacially retouched narrow flake (cf. 'rods', Saville 1981; SF 133; L=47mm, W=18mm, T=8mm).
- B.2.12 The microliths (all from Test Pit AAA) are classified (after Jacobi 1975; 1978) and described in Table 5. They are dominated by fragments of narrow backed bladelets with one fully backed lateral edge (12 examples), one of which bears some ancillary inverse retouch on the opposing lateral edge. These are accompanied by one fragment of bladelet with backing along both lateral edges, which could be classified as a rod, and two relatively small simple obliquely blunted points – only one of which is complete. None of the backed bladelet are complete, and many are made up of medial sections measuring between 10mm and 15mm long. As is often the case with this class of microlith, it is unclear to what extent these broken pieces may have been deliberately snapped/segmented prior to use (i.e. as inserts in composite tools), or instead represent broken fragment of larger tools. The typological affinities of the microliths are discussed in more detail below, but in general terms they form a relatively homogenous group and are consistent with a late Mesolithic date (c 7000-4000 cal BC).

Spit	Sample	SF no.	Type	Jacobi class	Condition/ breakage	Notes	Length (mm)	Width (mm)
1		189	Narrow backed bladelet	5a	Proximal portion	Right lateralised	>18mm	5mm
1	100		Narrow backed bladelet	5a	Distal portion	Right lateralised	>27mm	6mm
2	110		Narrow backed bladelet	5a	Medial portion	Left lateralised	>15mm	6mm
2			Narrow backed bladelet	5a	Proximal portion, burnt	Right lateralised	>14mm	4mm
2			Narrow backed bladelet	5a	Medial portion	?Right lateralised	>12mm	3mm
3			Narrow backed bladelet	5a/b	Distal portion, burnt	Right lateralised with ancillary inverse retouch on lower left lateral edge	>20mm	4mm
3	114		Narrow backed bladelet	5a	Medial portion	?Left lateralised	>12mm	4mm
4		526	?Obliquely blunted point	1a	Proximal portion	Right lateralised	>18mm	8mm
4			Narrow backed bladelet	5a	Distal portion	Right lateralised	>16mm	4mm
4			Narrow backed bladelet/rod	5b/6	Medial portion	Full backing both lateral edges	>15mm	6mm
4			Narrow backed bladelet	5a	Medial portion	?Left lateralised	>11mm	4mm
5		628	Obliquely blunted point	1a	Complete	Left lateralised	26mm	8mm

Spit	Sample	SF no.	Type	Jacobi class	Condition/ breakage	Notes	Length (mm)	Width (mm)
6			Narrow backed bladelet	5a	Medial portion	Left lateralised	>11mm	5mm
6			Narrow backed bladelet	5a	Medial portion, burnt	?Left lateralised	>10mm	5mm
8		788	Narrow backed bladelet	5a	Medial portion	?Left lateralised	>14mm	4mm

Table 5: Microliths from Test Pit AAA, scatter 8603

Other trenches and contexts

B.2.13 Aside from Trench 86, worked and/or unworked burnt flint was recovered from 30 other trenches across the evaluated area (see Table 6). The flint from these other trenches was recovered from a variety of contexts, but largely derived either from layers classified either as alluvial deposits or 'other layers', with smaller quantities of material from the 'natural' deposits, possible buried soils, subsoil, ploughsoil and unstratified contexts (Table 6). A notable feature of the assemblage is the almost complete lack of material from the fills of cut features: only natural feature 9005 (Trench 90) yielded a small assemblage of five worked flints (four flakes and a single chip). In most cases the flint assemblages derived from individual trenches were very small and included few distinctive/diagnostic pieces. Slightly larger assemblages of material were, however, recovered from some trenches, most notably from layers ('Other Layers') in Trenches 72 and 90 and from alluvial deposits in Trenches 20 and 25.

Type/context type	Alluvial Layer	Buried soil	Natural	Natural Feature	Other Layer	Ploughsoil	Subsoil	Unstrat.	Totals
Chip	6			1	7			1	15
Irregular waste	12				3		2	1	18
Flake	63	7	9	4	75	6	13	7	184
Blade	11	1			11			1	24
Bladelet	5				2				7
Blade-like flake	4								4
Crested removal					1				1
Piercer	1								1
Misc. retouched			1						1
Denticulate	1								1
Single platform flake core			1		1				2
Multiple platform flake core	1								1
Multiple platform blade/let core			1					1	2
Opposed platform core	1								1
Minimally worked core	2						1	1	4

Type/context t type	Alluvial Layer	Buried soil	Natural	Natural Feature	Other Layer	Ploughsoil	Subsoil	Unstrat.	Totals
Total worked	107	8	12	5	100	6	16	12	266
Unworked burnt flint count	19		1		36			1	57
Unworked burnt flint wt. (g)	264.7		4.1		225.4			0.4	494.6

Table 6: Basic quantification of flint from trenches other than Trench 86, by context type

- B.2.14 Trench 72 produced a total of 58 worked flints and 225g (35 fragments) of unworked burnt flint, all belonging to scatter 7205 and generally in good condition. The majority of the worked flints were recovered as surface finds (50 pieces), with a further eight pieces coming from the excavation of a single spit in Test Pit BAA, which also yielded most of the burnt flint (149g, 30 fragments). The worked flint from this trench included some blade-based material of earlier Neolithic or (more likely) Mesolithic date, including five fine blades (blade index = 9.8%), but many of the unretouched removals clearly derive from a very different technological strategy – consisting of very simple hard hammer struck flakes, often irregular and squat and frequently struck from cortical striking platforms. No retouched or clearly utilised tools are present and the only core is a simple single platform core made on a thermally split cobble from which a small number of flakes have been removed. The characteristics of much of this material are consistent with a later prehistoric date, almost certainly post-dating the later Neolithic and probably reflecting activity at some point during the 2nd millennium BC.
- B.2.15 A smaller assemblage of 17 worked flints was recovered from layer 9004 in Trench 90, accompanied by a further eight worked flints from the subsoil (9001) and the five flints from natural feature 9005 noted above. The material from both layer 9004 and subsoil 9001 are in comparable, good, condition. No cores or retouched tools are present but the technological signature of the assemblage, with a moderately high blade index of 19%, suggest that a substantial proportion relates to Mesolithic/earlier Neolithic activity.
- B.2.16 A total of 75 worked flints and 259g of unworked burnt flint were recovered from alluvial deposit 2002 in Trench 20 – representing the single largest assemblage of worked flint from a trench aside that from Trench 86. This flintwork is in generally good condition, but does include some slightly worn and edge damaged pieces. Although it has a moderately high blade index of 25.5%, the presence of simple hard hammer struck flakes alongside fine blades and bladelets strongly suggests this is a chronologically mixed assemblage, with Mesolithic/earlier Neolithic removals occurring alongside probable later prehistoric material. Three cores were recovered, but two were minimally worked/tested pieces and the third was a crudely worked flake core. The only retouched tool is a probable piercer, the broken distal end of a blade with abrupt dorsal retouch along both edges at its distal end converging to create a point, and is likely to be of Mesolithic or earlier Neolithic date.
- B.2.17 An alluvial deposit (2501) in Trench 25 yielded a further 15 worked flints. The only demonstrable/definite ‘early’ material in this assemblage is an opposed platform blade/bladelet core, and most of the assemblage is made up of simple flakes. The only retouched tool is a denticulate, a squat flake struck from a cortical striking

platform with some bold dorsal removals creating a short denticulated edge accompanied by some additional retouch on its ventral surface. Although sometimes occurring in earlier contexts, these kind of crudely manufactured denticulated tools become a common feature of assemblages over the course of the 2nd millennium BC, from the early Bronze Age into the later Bronze Age and Iron Age (Ford *et al.* 1984).

Discussion

- B.2.18 The most significant element of the flint from the evaluation is the very large assemblage recovered from scatter 8603, Trench 86. The assemblage from the test pit excavated in the western end of the trench (AAA), is extremely large, with flintwork recovered in unusually high densities, with 1254 flints recovered from a sequence of no more than 0.5m deep, of which 1053 were hand recovered and almost two thirds are over 10mm in size. Although in general terms the condition and the composition of the assemblage suggests this assemblage represents a minimally disturbed and essentially single period Mesolithic scatter, the presence of small quantities of early Neolithic pottery from the flint bearing layer (including from Test Pit AAA) indicates that the context from which the flint derives must have remained 'open' for some time following its original deposition, and the extent to which it represents multiple episodes of occupation and activity and/or has seen a degree of disturbance and loss of spatial integrity remains uncertain. These issues can probably only be resolved with larger scale investigation coupled with detailed analyses including refitting and spatial analysis combined with the geoarchaeological analysis of the flint bearing sediments and scientific dating.
- B.2.19 This uncertainty notwithstanding, the assemblage is remarkably consistent/coherent in technological and typological terms. The blade index is very high, and the assemblage overall exhibits a clear emphasis on the careful and structured production of regular, narrow blades and bladelets. Strictly diagnostic tool types and by-products are exclusively of Mesolithic date, including microliths, microburins and a 'tranchet' axe/adze sharpening flake, and forms diagnostic or suggestive of later prehistoric activity are almost entirely absent, with perhaps the best candidates for possible later prehistoric artefacts being a single broken scraper (SF 303) and the unusual 'rod-like' bifacially flaked implement (SF 133) - both recovered as surface finds rather than from the excavation of Test Pit AAA.
- B.2.20 Although it cannot be assumed that all of the microliths derive from the same episode of activity, they also form a strikingly homogenous group (see above, Table 3). The assemblage is dominated by narrow backed bladelets, a type with a long currency during the late Mesolithic of southern England (c 7000-4000 cal BC), together with two obliquely blunted points, one broken and one relatively small, slender example more comparable to those recovered from middle Mesolithic and some late Mesolithic assemblages than those from early Mesolithic contexts (Pitts and Jacobi 1979; Reynier 1994; 2005). The absence of other narrow blade microlith forms, especially scalene triangles, is notable and the restricted range of forms represented can be paralleled by a number of other late Mesolithic assemblages from southern Britain where narrow backed bladelets dominate, including Oakhanger III, Hampshire (Rankine 1952, 22-24); Kettlebury LIX, Surrey (Ellaby 1987) and elements of the very extensive scatters at Bletchingley, Surrey (Jones 2013). Such assemblages have often been suggested (tentatively and generally on typological grounds alone) to belong to an early/'pioneering' stage of the late Mesolithic, dating to the 7th millennia BC (Ellaby 1987, 63-4; Marples 2013). This argument has gained a measure of

support from the preliminary results of the Mike Donnelly's excavations on the route of the Bexhill to Hastings Link Road, Kent, where a programme of initial typological analysis and radiocarbon dating has isolated a group of late Mesolithic scatter characterised by narrow backed bladelets as belonging to the early part of the 7th millennium BC (Phase LM5 'early narrow blade'), potentially contemporaneous with the latest middle Mesolithic, Horsham-type, industries in the area (Champness et al. 2019). Although it would be premature to insist on a comparable date for some or all of the late Mesolithic material from Trench 86, it does raise the possibility that it belongs largely to the earlier part of the late Mesolithic, which would in turn suggest a significant hiatus between the major Mesolithic occupation(s) and the activity represented by the early Neolithic pottery from this trench.

- B.2.21 As noted above, the density of the scatter in the western part of the Trench, as sampled by Test Pit AAA, is very high. In comparison with recently excavated Mesolithic scatters in Southern England, the number of hand recovered pieces from this 1x1m area would fall into the higher end of densities encountered during the excavation of the c 135 Mesolithic flint scatters excavated on Bexhill to Hastings Link Road, where densities approaching or in excess of 1000 hand collected flints per 1x1m square were rare (M. Donnelly pers. comm), and is higher than any of the densities from individual 1x1m squares excavated during the extensive investigations at, Betchingley, Surrey (maximum density of c 500 hand recovered flints; Marples 2013, 109) or at Woodbridge Road, Guildford (maximum density c 500 pieces >15mm; Bishop 2008, 146). More widely, the density within Test Pit AAA are comparable to those of the highest densities of the corpus of early and middle Mesolithic scatters collated by Michael Reynier (Reyneir 2005, Table 6.2), although they fall short of the levels seen at certain demonstrably long-lived and complex middle to late Mesolithic scatters at sites such as Broom Hill, Hampshire (O'Malley and Jacobi 1978), Wawcott III, Berkshire (From 1976; 2012), Farnham, Surrey (Clark and Rankine 1939) and Blick Mead, Wiltshire (Jacques *et al.* 2018). The high density of artefact in the area of Test Pit AAA could result from numerous factors including the relative intensity and duration of occupation(s), depositional practices involving the deliberate dumping/accumulation of material and/or taphonomic, post-depositional, processes which may have led to the accumulation of material through natural agencies such as slope processes. Regardless of the mechanism(s) behind the high densities, it is clear from the distribution of surface finds and the excavation of test pit ADD that such high densities were restricted to the western end of the trench, although the extent of the 'core' of the scatter beyond that remains uncertain. Even allowing for a very concentrated scatter, covering a small area, further excavation clearly has the potential to yield a very large assemblage of flintwork, potentially numbering in the tens of thousands.
- B.2.22 As discussed elsewhere in relation to Mesolithic scatters revealed by parallel evaluation work undertaken some 4km to the south-east to the west of Linford, East Tilbury (OCA 2022b), the discovery of substantial, single period Mesolithic assemblages such as that represented by the Trench 86 assemblage are of considerable regional importance. The record of this period in Essex and other parts of Eastern England has long been dominated by lithic material from poorly stratified multiperiod assemblages, often recovered under less than stringent circumstances (Jacobi 1980; 1996), and the Trench 86 assemblage has clear potential to contribute to regional research objectives in terms of developing understandings of the chronology and character of late Mesolithic activity, and joins a small number of well-documented Mesolithic scatters revealed by recent developer funded work along this

stretch of the Lower Thames Valley (Leivers *et al.* 2007; Champness *et al.* 2015). Given the distinctive typological make-up of the assemblage, any opportunity to obtain secure/reliable radiocarbon dates in association with his flintwork also has the potential to contribute to wider debates concerning the development and chronology of late Mesolithic narrow blade technologies in Southern England.

B.2.23 Aside for the Trench 86 assemblage, the remainder of the flintwork from across the site includes very few distinctive/diagnostic forms and in many cases the material from individual contexts is clearly chronologically mixed, including several assemblages (most notably that from Trench 72 (scatter 7205)) which include very simple flake-base material likely to be of Bronze Age date. Although the generally small quantities of material recovered from individual contexts and the lack of diagnostic forms renders interpretation difficult, it is clear that flintwork is widely distributed across certain part of the site within subsoils, alluvial deposits, possible buried soils and in the top of the underlying 'natural' substrate. This material is often in relatively good condition and suggests that there is considerable potential for further significant minimally disturbed scatters, of both Mesolithic and later prehistoric date, to survive in other parts of the evaluated area.

Context	Context type	Chip	Irregular waste	Flake	Blade	Bladelet	Blade-like flake	Core tablet	Crested removal	Axe/adze sharpening	Microburin	Scraper	Piercer	Microolith	Misc. retouched	Denticulate	Bifacially worked	Edge trimmed blade	Single platform flake	Multiple platform flake	Single platform blade/let	Multiple platform	Opposed platform core	Discoidal core	Retouched core	Minimally worked core	Total worked	Unworked burnt flint wt. (g)	
1400	Ploughsoil			1																						1			
1416	Alluvial layer			1																							1		
1900	Ploughsoil			1																							1		
2002	Alluvial layer	5	11	39	9	5	2					1							1						2	75	259		
2202	Alluvial layer			7																							7		
2203	Buried soil			1																							1		
2401	Subsoil		1	5																					1	7	37.1		
2501	Alluvial layer	1		12											1								1				15	85.4	
2601	Buried soil			6																							6		
Unstrat	Unstrat		1	1																							2		
3002	Other layer		1	4	1	1																					7		
Unstrat	Unstrat	1		5																		1			1	8	46.1		
3702	Other layer	1		10	2																						13		
4400	Ploughsoil			1																							1		
4402	Natural			5															1								6	174	
4500	Ploughsoil			1	1																						2		
4604	Buried soil				1																						1		
5502	Natural														1												1		
6008	Other layer			1																							1		
6100	Ploughsoil			1																							1		
6102	Other layer			1																							1		
6300	Ploughsoil			1																							1		
6902	Natural			3																			1				4	46.8	
7205	Other layer	4	2	46	5														1								58	225	
7904	Alluvial layer																											6.1	
8402	Natural			1																							1	4.1	
8600	Ploughsoil			2																							2		

Context	Context type	Chip	Irregular waste	Flake	Blade	Bladelet	Blade-like flake	Core tablet	Crested removal	Axe/adze sharpening	Microburin	Scraper	Piercer	Microolith	Misc. retouched	Denticulate	Bifacially worked	Edge trimmed blade	Single platform flake	Multiple platform flake	Single platform blade/let	Multiple platform	Opposed platform core	Discoidal core	Retouched core	Minimally worked core	Total worked	Unworked burnt flint wt. (g)
8603	Other layer	461	19	461	141	164	22	2	4	1	3	1		15	2		1	1			3		5	1	1		1308	731
8605	Other layer			3	1																						4	
9001	Subsoil		1	7																							8	
9004	Other layer	2		10	3	1																					16	
9006	Natural feature	1		4																							5	
9300	Ploughsoil			1																							1	
9403	Other layer			1																							1	
9602	Other layer			1					1																		2	
10707	Alluvial layer			1																							1	
10909	Other layer			1																							1	
11002	Alluvial layer				1																						1	
12001	Subsoil			1																							1	
28103	Alluvial layer		1	3	1		2																				7	

Table 7: Summary catalogue of flint by context

B.3 Fired Clay

By Kirsty Smith

Introduction

- B.3.1 A very small quantity of fired clay amounting to 14 fragments weighing 136g was recovered from Trenches 44, 84 and 86. The assemblage consists of small and moderately sized fragments, with a mean fragment weight of 9.7g. A perforated plate from context 4402 can be dated to the late Bronze Age, the rest of the fragments cannot be dated due to an absence of diagnostic material. The assemblage is summarised in Table 8 below and has been more fully recorded on an Excel spreadsheet in accordance with guidelines set out by the Archaeological Ceramic Building Materials Group (ACBMG 2007), which whilst not specifically for fired clay provide appropriate guidance. Fabrics were characterised on the basis of macroscopic features supplemented by the use of x20 hand lens for finer constituents.

Fabrics

- B.3.2 Two different fabrics were present in the assemblage. The fired clay from context 4402 and associated fragments were made from an orange-red silty fabric which contained frequent angular burnt flint grits 0.1-2.5mm long. The fragments of fired clay from contexts 8402 and 8603 were made from an orange-red fine sandy fabric with occasional quartz grits 0.1mm.

Description

- B.3.3 Ten fragments of fired clay within flint inclusions were recovered from content 4402 and two of these fit together to form part of perforated plate. This plate was 17mm thick and was polygonal in shape with three surviving sides, a complete width of 62mm and a length 67mm+. Along the broken main body of the plate was the remains of a perforation (around 40% of the total) which was 19mm diameter. This perforated plate is late Bronze Age in date and would have been used as portable oven or hearth furniture. Many examples of this type have been recorded from sites in the middle and lower Thames Valley and Thames estuary and the form has been analysed and discussed in some detail by Champion (2014). Context 4402 was recorded as the natural substrate.
- B.3.4 One fragment of fired clay (45g) was recorded from context 8402 (also the natural substrate). This fragment had one flattish surface and side and appeared to have been baked. The fragment was discoloured light grey on one side. It is possible that this fragment formed part of an oven structure.
- B.3.5 Three indeterminate fragments of fired clay (9g) were recorded from contexts 8603. These fragments were amorphous and heavily abraded. They were not distinctive, and their original form is unclear. This context is associated with a flint scatter.

Context	Sample	Nos	Weight (g)	Form	Comments
4402	~	10	82	Perforated plate	Polygonal flattish plate with three sides. There is a hole 19mm diam along one broken edge. Two large fragments join.
8402	~	1	45	Structural	?oven/hearth. Surface discoloured dark grey
8603	<304>	1	4	Indeterminate	
8603	~	2	5	Indeterminate	

Table 8: Summary of fired clay assemblage

Conclusion

- B.3.6 The assemblage of fired clay is small, but the perforated plate is of some significance as it suggests late Bronze Age settlement activity in the vicinity of Trench 44 of the site. The fragment of fire clay from Trench 84 may have also originated as part of an oven. The other amorphous fragments from Trench 86 are associated with a flint scatter and may be contemporary. Trenches 44, 84 and 86 are located in a low-lying area just east of the Mar-Dyke where deposits of head clay and alluvium have been mapped.

Recommendations

- B.3.7 The assemblage is small, but the late Bronze Age perforated plate is of some significance and has further research potential. The fragment of possible oven structure should also be retained but the two amorphous fragments can be discarded if desired at completion of the project.

B.4 Briquetage

By Alex Davies

- B.4.1 A single 4g fragment of briquetage vessel was recovered from context 3702 in Trench 37. It is pink in colour and has a fine vegetal (grass/chaff) fabric similar to the briquetage found at LTC7L and LTC15T, of which at least some was dated to the late Bronze Age. The fragment can only be broadly dated to the late Bronze Age to late Roman period.

B.5 Waterlogged Wooden Objects

by Damian Goodburn

Introduction

- B.5.1 Archaeological trial trenching of palaeochannels in the low-lying valley of the Mar Dyke river revealed a row of 6 wooden 'stakes' in Trench 14 crossing part of a silted up palaeochannel (Fig. 5; Plate 3). The stakes were driven through alluvial clay deposits and had pierced the London Clay base of the channel. Basic records were made of the stake alignment on site by the OCA team and two of the best-preserved stakes from the eastern trench edge (stakes 1410 and 1422) were lifted for more detailed recording off site. The two lifted stakes were driven in c 0.75m apart and had lost their tops to ancient decay and erosion (Fig. 13; Plate 4).
- B.5.2 Species identification of the timbers was carried out at Oxford Archaeology South (see Meen this volume), and both were identified as oak. The outer rings of stake 1422, which included sapwood, were sampled and radiocarbon dated to determine whether the structure was ancient or relatively recent, and provided a broad date range of c 760-410 BC i.e. early Iron Age. This specialist was therefore invited to record the timbers and assess their significance.

Methodology and condition

- B.5.3 The two stakes were lifted together with adhering sediment and carefully double wrapped in polythene by the site team for transportation to Oxford and then to the writer's home in Kent. The timbers were then further gently cleaned using water and recorded with proforma timber sheets and scale drawings, in accordance with Historic England guidelines (English Heritage 2010). Unfortunately, both stakes were found to have been eroded in prehistory and were somewhat mineralised, possibly as a result of recent periods of low water level. This meant that the survival of tool marks was limited. Additionally stake 1410 had shattered along the grain into many sections only held together by the adhering clay.
- B.5.4 Maximum dimensions given are those measured off site. Traces of the Trench 14 timbers seen as decayed organic material above the surviving wood, which did not survive lifting, could not be included. Vertical timbers such as this will only survive to the level of permanent waterlogging, the buried wood above this rotting gradually due to seasonal drying out, while any length exposed above ground will have rotted away in prehistory.

Detailed recording

- B.5.5 Stake 1410 survived 0.69m long from the point to the rotted top and was 110mm wide by 70mm thick (Plate 4). It was of oak, and was made from a cleft ¼ log from a moderately straight tree around 0.3m in diameter with apparently less than 45 surviving annual rings. This size and degree of conversion and trimming means that it is 'timber' rather than 'roundwood'. The cleft quarter log had been further axe trimmed on two faces to achieve an irregular four-sided finished shape (Fig. 13). Unfortunately the timber had suffered some surface ancient decay and mineralisation and some of the surface was concreted. The irregular pointed tip bore small concave axe facets typical of later prehistoric work, the widest being 40mm wide. However, no clear 'stop marks' mirroring the form and width of the axe blade end were found, so the axe used can only be described as a small convex metal blade over 40mm wide. Small rounded axe marks of this broad form are known from both the late Bronze Age

and early Iron Age from studies of larger, better-preserved material such as the Eton Rowing Course and the recent A14 project.

- B.5.6 Stake 1422 was also of oak, and was very similar in character to stake (1410) but was longer and more intact, at 1.02m long by 90mm wide and 90mm thick (Plate 5). It was axe-trimmed to an irregular four-sided cross section from a cleft ¼ log of oak, and when found sapwood was clearly visible along one face (Fig. 13), though mineralisation now obscures that feature. The parent log would have been very similar to that used for stake 1410. The tip had been axe-cut to an irregular point bearing concave facets up to 35mm wide, and was probably cut with a very similar, or identical, axe to that used for stake 1410. No trace of the marks of the wider, straighter blade form of many early Iron Age socketed iron axes was found on either stake tip, but as none of the tool marks are complete this is not conclusive.

Discussion

- B.5.7 Site photographs and section drawings show that the two lifted stakes timbers (1410) and (1422) had decayed tops surviving in the alluvial clay up to c +2.35m aOD. Multiple systematic excavations along the Thames estuary flood plain and the lowest parts of its tributary channels in east London and the adjoining areas of Kent and Essex have provided evidence of the survival of prehistoric and early historic timber and roundwood structures (Stafford *et al* 2012; Goodburn and Davis 2010).
- B.5.8 The stakes found at the Mar Dyke were only exposed in a single trench, which was not extended to determine the full length of the structure or the full width of the channel in which it was contained. In addition, the stakes were not identified at the level to which the wider trench was cut, only appearing when the centre of the trench was stepped down. As a result we do not know whether the structure represented by the stake line was accompanied by another line of stakes, or even by multiple lines, as was the case in some structures at the Eton Rowing Course (*ibid.*). This makes any interpretation of the structure very speculative, and this is best left until any further archaeological mitigation has been completed.
- B.5.9 Very little Iron Age woodwork of similar character to the stakes from Tr 14 has been found and reported on in detail in the Lower Thames estuary or its hinterland. One modest example is a short roundwood stake alignment along the banks of the Neckinger river in London, close to its confluence with the tidal Thames (Leary *et al.* 2011). At that site the timber survived adjacent to a small probable river embankment. Later Bronze Age structural woodwork is far more common along the estuary shores and just above them, only a small proportion of the later Bronze Age structures provide close parallels for the situation and character of the structure from Tr 14 here. Many of the later Bronze Age structures are trackways using diagonally angled stake alignments and planks, or timber platforms rather than vertical lines of stakes.
- B.5.10 As assessment has indicated that the Mar Dyke was not tidal as far upriver as Trench 14, then parallels on freshwater rivers might be more appropriate, and would include the series of Iron Age structures from the Eton Rowing Course in the middle Thames at Dorney. Here a series of double lines of stakes interpreted as bridges, generally 2m apart, were found and reported upon by Maisie Taylor (Taylor and Mitchell in Allen *et al.* forthcoming). The stakes in these alignments were all of oak, and were mostly roundwood, surviving up to 2m long and generally 100–170mm in diameter, axe-trimmed to a point. Radiocarbon dating has established that four of these structures were of early Iron Age date and one of middle Iron Age date. Several smaller

alignments of stakes were also found in the same deposits, though not individually dated, two consisting of a single line of posts up to 1m apart, and with stakes up to 1m in surviving length and 40-100mm across. In both the bridges and smaller timber alignments a proportion of the stakes were halved or quartered roundwood timbers, some with further trimming.

The significance of the stake structure in the Mar Dyke valley

- B.5.11 The stake group found in Trench 14 derives its key significance from its location and broad dating to the early Iron Age, which is little known for waterlogged woodwork of any kind in the South-East of England. The structure may also prove to be more complex than the single short line of stakes found at evaluation stage, and should be considered of regional importance.

Potential for further analysis and retention

- B.5.12 The stakes have just too few annual rings for tree ring dating to be attempted to refine the date of the structure, as this requires at least 50 annual rings to be present. The management of oak by coppicing to produce fast-growing oak timber in the early Iron Age was noted at the Eton Rowing Course, and this may also be the case for the timbers used at the Mar Dyke.
- B.5.13 Examination of small numbers of timbers is always less informative than of larger groups, where patterns of woodworking reduction can be recognised that are not evident in few examples. Examination of the ring growth patterns in larger numbers of timbers can demonstrate how many different trees were used to create the structure, and link different stakes made from the same trees. While there is limited further information available from these two timber stakes by themselves, further examination of the structure to which they belong is likely to provide much more information.
- B.5.14 One of the recovered timbers is already in an advanced state of disintegration, but the other may be able to be preserved for long enough for comparison should further archaeological mitigation that involves this structure be required in the near future. A wider search for parallels would also be worthwhile at that stage to provide better context for the Mar Dyke structure and more clues as to its purpose.
- B.5.15 Should no further mitigation be necessary, an illustrated specialist report upon these timbers and the structure to which they belong, based upon this report, should be included in the eventual publication of the project.

C.1 Charred Plant Remains

By Richard Palmer

Introduction

- C.1.1 Twenty-two bulk samples were taken from the evaluation of land parcels 47 and 48f-h, primarily for the retrieval and assessment of charred plant remains and the recovery of small bones, shell and artefacts.
- C.1.2 Samples were also taken for the recovery of waterlogged plant remains and other anaerobically preserved material, and soil monoliths were taken to provide material for microfossil (pollen, diatoms etc) and soil analysis if warranted. Optically Stimulated Luminescence dating samples were also taken. These are all reported separately.

Method

- C.1.3 The bulk samples were processed in their entirety at Oxford Archaeology using a modified Siraf-type water flotation machine. The flots were collected in a 250µm mesh and residues in a 500µm mesh and dried. The residue fractions were sorted by eye and with the aid of a magnet while the flot material was sorted using a low power (x10) binocular microscope to extract cereal grains and chaff, smaller seeds and other quantifiable remains. Four samples (28, 29, 32 and 55) potentially included significant levels of anaerobic preservation so 1L subsamples were taken prior to processing the samples as above. Following this assessment the subsample from sample 55 was processed and assessed by Cook (below).
- C.1.4 Charcoal identifications were made using a high power (x50 to x400) microscope to identify diagnostic features.
- C.1.5 Nomenclature for identified species follows Stace (2010). Charcoal identifications are made with reference to Schweingruber (1990) and cereal and chaff identifications with reference to Jacomet (2006).

Results

- C.1.6 Sample and flot abundance data are recorded in Table 9.
- C.1.7 **Trench 6.** Four samples (96, 101, 102 and 103) were taken during excavation of possible cremation feature 605. Samples 96, 101 and 102 are from three spits through the cremation fill 606 and 103 originates from natural 604 underlying the feature. 96, 101 and 102 are charcoal rich with ring and diffuse porous type taxa present. Sample 103 produced only a few miscellaneous charcoal flecks. Charcoal from samples 96 and 101 was identified indicating the presence of oak (*Quercus* sp.) and apple/hawthorn (*Maloideae*). Calcined bone was recovered from the spit sample residues with no bone or artefactual material present in the heavy residue of sample 103.
- C.1.8 **Trench 13.** Sample 143 from fill 1312 of posthole 1311 produced a large charcoal rich flot which includes oak and apple/hawthorn charcoal. Calcined bone was present in the heavy residue.

- C.1.9 **Trench 72.** Sample 113 was taken from layer 7205 as part of the gridded excavation of flints. It produced a poor flot but some flint was extracted from the heavy residue.
- C.1.10 **Trench 86.** Ten samples were taken during gridded excavation of a late Mesolithic flint scatter (context 8603) in this trench. Pottery from this spread has been dated to the early Neolithic period (Davies *Infra*) so the date of any charred remains is probably best described as likely to be late Mesolithic/early Neolithic if not intrusive. Most of the flots contained mainly uncharred plant debris and roots and little in the way of charred material. The only samples of note are sample 100 where an indeterminate cereal grain was identified, sample 134 where a small fragment of hazelnut shell (*Corylus avellana*) was recovered and sample 161 which includes several fragments of ring-porous type charcoal. Flint was recovered from most of these samples with pottery also recovered from sample 114.
- C.1.11 **Trench 90.** Sample 57 from fill 9008 of cremation feature 9007 produced a small flot. Charcoal is in fair to poor condition and most of the flot volume is made up of charred material <2mm in size. Calcined bone was recovered from the heavy residue.
- C.1.12 Sample 84 is from natural 9003 below cremation 9007. The flot is poor with no charred material larger than 2mm. The residue was also free of calcined bone and artefacts.
- C.1.13 **Trench 94.** Sample 32 from layer 9413 produced a flot lacking any charred material and the volume mostly consisting of dried-out uncharred plant material. Some charcoal was recovered from the heavy residue, but no artefacts were present. A subsample was taken for the assessment of waterlogged remains which is reported separately.
- C.1.14 **Trench 109.** Samples 28 and 29 are from undated layers 10908 and 10909. The flots consist of dried-out but formerly waterlogged material. No charred material is present beyond the few charcoal fragments in sample 29. No artefacts were recovered from the heavy residues of either sample.
- C.1.15 **Trench 111.** Sample 55 was taken from layer 11103 produced a flot consisting of dried-out formerly waterlogged material and no charred plant remains or charcoal. No artefacts were recovered from the heavy residue. A subsample was taken for the assessment of waterlogged remains which is reported separately.

Discussion

- C.1.16 The samples indicate limited potential for the recovery of charred material. This may in part be due to the nature of the sampled features, ten samples were taken from a flint scatter and did not offer much in the way of charred plant remains or charcoal. Other samples were taken from waterlogged organic layers which also were largely devoid of charred material. Charcoal was recovered from the cremations and a large quantity of it was recovered from posthole 1311.
- C.1.17 Sample 100 is of interest due to the presence of a single cereal grain in a potentially late Mesolithic flint scatter. The grain is damaged with one end missing so is identified only as *Cerealia*. Unfortunately, weighing 0.009g it is unlikely to be heavy enough to provide a radiocarbon date, but any further sampling of this or other scatters of similar date should focus on the recovery of charred plant remains as well as flint as a radiocarbon date on any cereals associated with a late Mesolithic or early Neolithic scatter would be very significant.

Recommendations for retention/disposal

C.1.18 The flots warrant retention until all works on project are complete. The charcoal from the cremation samples may be suitable for further species identification and may offer potential for radiocarbon dating. The flots containing no viable charred material have no research value and may be discarded as part of final archiving and deposition.

Sample	Context	Feature/Deposit	Date	Sample vol. (L)	Flot vol. (ml)	Charcoal >2mm	Grain	Chaff	Weeds	Other Charred	Molluscs	Notes
28	10908	10908		21	16							Very dark brown silty clay
29	10909	10909		21	34	+						Mid grey brown silty clay
32	9413	9413		18	26	++						Mid brownish grey clay
55	11103	11103		21	18							Dark greyish brown silty clay
57	9008	9007		14	24	++						Dark brownish black silty clay
84	9003	9003		8	3							Mid orange brown clay
96	606	605		7	375	++++						Dark brownish black silty clay
100	8603	8603	L Meso	36	25	++	+					Light brown clay
101	606	605			415	++++						Dark brownish black silty clay
102	606	605		8	25	++++						Dark greyish brown clay
103	604	604		8	5	+						Light greyish brown clay
110	8603	8603	L Meso	34	16	+						Mid grey silty clay
113	7205	7205		36	5	+			+			Mid grey brown silty clay

114	8603	8603	L Meso	36	18	+							Mid orange brown silty clay
119	8603	8603	L Meso	34	1								Mid grey brown silty clay
124	8603	8603	L Meso	34	16	+							Mid brown silty clay
134	8603	8603	L Meso	32	20						+		Mid greyish brown silty clay
139	8603	8603	L Meso	32	10	+				+			Mid brown silty clay
143	1312	1311		6	595	++++							Dark blackish brown silty clay
161	8603	8603	L Meso	30	16	++							Mid orangey brown silty clay
174	8603	8603	L Meso	28	150							+	Mid brown clay
182	8603	8603	L Meso	30	50								Mid brown clay

Key: +=present (up to 5 items), +=frequent (5-25), +++=common (25-100), ++++=abundant (100+).

Other Charred covers nutshell and legumes

Table 9: Assessment of bulk samples

C.2 Waterlogged Plant Remains

By Sharon Cook

Introduction

C.2.1 In addition to the samples taken from dry deposits, 53 bulk samples were taken from organic, waterlogged deposits were taken during the evaluation. These samples, mainly of 10L, were taken for the retrieval and assessment of Waterlogged Plant Remains (WPR), insects and Mineralised Plant Remains (MPR), and to establish the potential for the recovery of identifiable remains and more generally the extent of anaerobic preservation. In addition, one of the samples from what was thought to be a dry deposit (sample 55) showed evidence of waterlogging and was subsampled and assessed together with the other WPR samples.

Method

C.2.2 One litre of each sample was processed at Oxford Archaeology using the wash over method. Both flots and residues were collected in 250µm meshes and kept wet to facilitate preservation. The flot material was scanned using a low power (x10-x40) binocular microscope to identify any plant and other quantifiable remains, while a subsample of each residue was scanned to identify the potential for mineralisation. 50ml of each flot was scanned or 100% if less than 50ml.

C.2.3 Identification of wild plant remains is with reference to the Digital Seed Atlas of the Netherlands (Cappers *et al.* 2012) and by comparison with modern reference material. Classification and nomenclature of plant material follows Stace (2010).

Results

C.2.4 A summary of the samples is presented in Table 10 and the results of the assessment in Table 11. The samples came from potential alluvial layers and buried soils within Trenches 7, 14, 16, 73, 94, 97, 102, 107, 109, 111 and 112. The flots from this site vary considerably in terms of volume and abundance of preserved plant and insect remains although overall the preservation of seeds is good.

C.2.5 Insect remains are generally fragmentary although occasional smaller specimens remained intact, and elytra are present in many samples. Snails are not present in any of the flots, which is typical for peaty deposits. Flecks of charred plant material, particularly charcoal, occur in several flots but are <2mm and not suitable for further identification.

C.2.6 *Daphnia ephippia* and bryozoan statoblasts are common and present across the site confirming that flooding was a common occurrence, although potentially seasonal.

C.2.7 **Trench 7.** Twelve samples were taken from layers within the main body of the trench (162-166) and from the fills of a Palaeochannel at the SE end (167-173).

C.2.8 Those samples taken from alluvial layers within the trench largely comprise root and stem fragments with small fragments of humic material and occasional small fragments of wood. Insects are rare except within samples 165 and 166 both of which contained abundant, but extremely fragmented, remains. *Daphnia ephippia* and bryozoan statoblasts in sample 166 demonstrate that the deposit was at least seasonally flooded and there a small quantity of waterlogged seeds.

- C.2.9 Of the channel samples, 171, 172 and 173 contain little other than root and stem fragments. The flots from samples 167, 168, 169 and 170, by contrast, contain abundant insect fragments and common waterlogged seeds which include aquatic plants such as pondweed (*Potamogeton* sp), water plantain (*Alisma* sp.) and water crowfoot (*Ranunculus* sub gen *Batrachium*) in the lower fills as well as seeds from plants of waterside and damp places such as sedges (*Carex* sp), spike rush (*Eleocharis* sp.), water dropwort (*Oenanthe* sp.), and, especially in the fills higher up in the sequence (eg fill 706), plants of waste places such as dock (*Rumex* sp.), gypsywort (*Lycopus europaeus*), bramble (*Rubus* sp.) and daisy family (cf *Artemisia* sp.)
- C.2.10 **Trench 14.** Of the ten bulk samples taken from Trench 14 (70-79), samples 70 and 71, and samples 76-79 contain very little waterlogged material other than fragmented roots and stems, although small fragments of charcoal (mainly <2mm) are present in most of these fills.
- C.2.11 Sample 72 from layer 1414 is rich in fragmented insect remains (in contrast to sample 71 from the same context) and contains *Daphnia ephippia* and bryozoan statoblasts. These are also present with samples 73, 74 and 75 from alluvial layers 1415 and 1416 together with well-preserved seeds typical of plants of waterside and damp grassland. These samples came from deposits associated with a wooden post (1422) and show that waterlogged material is generally well preserved in this area.
- C.2.12 **Trench 16.** The samples from Trench 16 (179-181) came from a sequence of alluvial deposits in paleochannel 1613. While sample 179 from 1608 contains abundant insect fragments and well-preserved seeds from plants of slow moving water, waterside and damp grassland, the remaining samples contain much less material.
- C.2.13 **Trench 73.** Sample 135 from alluvial layer 7304 contains only root and stem fragments together with occasional small fragments of charcoal <2mm.
- C.2.14 **Trench 94.** Five samples were taken from Trench 94. Samples 43, 44 and 107 from context 9403 show an increase in the quantity of waterlogged material through the deposit with seeds indicative of standing or slowly flowing water and bankside deposits. While in terms of numbers seeds are not common, insect fragments appear to increase through the deposit, possibly because of settling over time. Sample 45 contains mainly fragmentary material while sample 109 from alluvial layer 9411 includes some bramble seeds potentially indicating an area of drier ground nearby.
- C.2.15 **Trench 97.** The four samples from Trench 97 (120-123) from a sequence of alluvial and colluvial layers, contain common insect remains and waterlogged seeds indicative of standing or slow moving water and damp ground, together with *Daphnia ephippia* and bryozoan statoblasts in a good state of preservation.
- C.2.16 **Trench 102.** Samples 85 and 86 from a sequence of alluvial layers within Trench 102 also contain common insect remains and waterlogged seeds of similar types to those in other trenches, together with *Daphnia ephippia* and bryozoan statoblasts in a good state of preservation.
- C.2.17 **Trench 107.** Samples 7 and 40 from alluvial layers within Trench 107 contain mainly roots and stalks with rare seeds and few insect fragments. These contrast with sample 42 which is richer in seeds but has very little variation in taxa (sedge and celery leaved buttercup *Ranunculus sceleratus*) and sample 41 which is peaty in

nature. All contain small numbers of *Daphnia* ephippia indicating potentially varying water levels.

- C.2.18 **Trench 109.** Samples 30-31 and 46-47 from humic buried soil layers within Trench 109 contain abundant root and stem fragments. Waterlogged seeds are common (especially water crowfoot and water plantain in samples 30 and 31 and also pondweed and spike rush in samples 46 and 47) despite the small size of many of the flots and insect fragments and *Daphnia* ephippia are also well represented. Occasional fragments of charcoal are present but are mainly <2mm.
- C.2.19 **Trench 111.** The six samples from Trench 111 (48-55) are from a sequence of alluvial deposits interspersed with buried earth/peaty layers. All contain seeds indicative of standing or slow moving water and damp places as well as insect remains in good numbers and *Daphnia* ephippia and statoblasts. Small fragments of charcoal are present with samples 51 and 54, however these are mainly <2mm in size. Preservation of the waterlogged material is generally good.
- C.2.20 **Trench 112.** Samples 104-106 from alluvial layers within Trench 112 produced large flots with abundant roots and stems. Seeds and insect remains are common except within sample 106 which is generally smaller overall. Seeds include sedge, water plantain, water crowfoot, water dropwort and knotweed (*Persicaria* sp.). Ephippia and statoblasts are present within context 11213 but were not noted in context 11214.

Discussion and conclusions

- C.2.21 While many of the flots produced on this site are not large there is evidence of good preservation of waterlogged plant remains and insect remains in many of the trenches. Occasional peaty deposits and the fills of several palaeochannels indicate long term waterlogging of much of the area with good preservation resulting.
- C.2.22 Those seeds present are largely those with a preference for standing or slow moving water, wet and boggy conditions such as pondweed (*Potamogeton* sp.), spike rushes (*Eleocharis* sp.), sedges (*Carex* sp.), water-dropwort (*Oenanthe* sp.) and celery-leaved buttercup (*Ranunculus sceleratus*). Rare grass seeds (Poaceae), brambles (*Rubus* sp.) and docks (*Rumex* sp.) may be the result of dryer phases or represent plant growing on small patches of higher ground within the marshy area.
- C.2.23 The small size of the charcoal fragments may indicate that they have moved through the soil through bioturbation. An *in situ* deposit would be expected to contain larger and more frequent fragments.
- C.2.24 The presence of water flea (*Daphnia* sp.) ephippia together with bryozoan statoblasts within many of the flots demonstrates that this area has been under water previously. Ephippia are dormant eggs produced to cope with unfavourable conditions by waiting to develop and hatch when conditions become more favourable (Pietrzak and Slusarczyk 2006). They are likely to indicate fluctuations in the aquatic environment such as periodic drying and as such on this site are likely to indicate seasonal flooding, with the ephippia 'resting' over the dry period to resume development later.
- C.2.25 Likewise, bryozoans are small filter feeding animals that are common within aquatic environments. They produce statoblasts by asexual reproduction and like ephippia, these function as survival pods with their ability to remain dormant to survive unfavourable conditions before then forming a new colony when conditions become more favourable (Ruppert et al 2004, 830).

C.2.26 The presence of these in such abundance indicates that this was an area frequently (although not permanently) underwater with fluctuations in the water level over time, possibly a result of seasonal flooding.

C.2.27 The levels of preservation observed in these samples shows that there is good potential in this part of the valley for a range of features to contain identifiable waterlogged plant remains and insect remains. Mollusc shells do not appear to survive.

Recommendations for retention/disposal

C.2.28 The flots warrant retention until all works on site are complete but long term storage in the archive is not considered to be necessary.

Sample	Context	Depth (m BGL)	Feature Type	Soil Description
162	702		Layer	5YR 5/4 reddish brown silty clay
163	703		Alluvial Layer	7.5YR 4/2 brown silty clay
164	704		Alluvial Layer	7.5YR 3/3 dark brown silty clay
165	705		Layer	7.5YR 3/2 dark brown silty clay
166	706		Layer	7.5YR 4/2 brown silty clay
167	713		Channel fill	7.5YR 3/1 very dark brown silty clay
168	714		Channel fill	7.5YR 3/2 dark greyish brown silty clay
169	715		Channel fill	10YR 5/1 grey silty clay
170	716		Channel fill	10YR 4/1 dark grey silty clay
171	717		Channel fill	2.5Y 5/2 greyish brown silty clay
172	718		Channel fill	10YR 6/2 grey silty clay
173	719		Channel fill	7.5YR 6/1 grey silty clay
70	1412	0.33-0.40	Alluvial Layer	10YR 4/3 brown silty clay loam
71	1414	0.60-0.70	Alluvial Layer	10YR 4/4 dark yellowish brown clay loam
72	1414	0.70-0.80	Alluvial Layer	7.5YR 3/3 dark brown silty clay loam
73	1415	0.80-1.10	Alluvial Layer	10YR 5/2 greyish brown clay loam
74	1415	1.00-1.20	Alluvial Layer	10YR 5/2 greyish brown clay loam
75	1416		Alluvial Layer	10YR 5/2 greyish brown silty clay loam
76	1417		Alluvial Layer	2.5Y 5/6 light olive brown clay loam
77	1418		Natural	10YR 6/2 light brownish grey silty clay loam with orange mottling

Sample	Context	Depth (m BGL)	Feature Type	Soil Description
78	1424		Alluvial Layer	10YR 6/3 pale brown clay loam
79	1425		Alluvial Layer	10YR 5/2 greyish brown silty clay loam
179	1608	1.4	Channel fill	7.5YR 5/1 grey silty clay
180	1609	1.65	Channel fill	7.5YR 5/1 grey silty clay
181	1610	1.9	Channel fill	5YR 4/1 dark grey silty clay
135	7304	0.54-0.65	Alluvial Layer	7.5YR 3/4 dark brown clay loam
43	9403	0.90	Layer	5YR 3/3 dark reddish brown clay loam
44	9403		Layer	7.5YR 3/2 dark brown silty clay loam
45	9407		Layer	10YR 5/2 greyish brown clay loam
107	9403	1.2	Layer	5YR 3/2 dark reddish brown clay loam
108	9415	1.5	Alluvial Layer	10YR 4/2 dark greyish brown silty clay
109	9411	1.8	Alluvial Layer	10YR 5/1 grey silty clay
120	9726	2.20 - 2.40	Alluvial Layer	10YR 3/2 very dark greyish brown silty clay
121	9727	2.40 - 2.60	Alluvial Layer	10YR 3/2 very dark greyish brown silty clay
122	9728	2.60 - 2.80	Alluvial Layer	10YR 3/1 very dark grey silty clay
123	9729	2.80 - 3.00		10YR 5/2 greyish brown silty clay
85	10210		Alluvial Layer	10YR 2/2 very dark brown silty clay loam
86	10211		Alluvial Layer	10YR 3/1 very dark grey silty clay loam
7	10704		Alluvial Layer	10YR 3/2 very dark greyish brown silty clay
40	10706	1.25	Alluvial Layer	5YR 3/1 very dark grey silty clay
41	10703	0.72	Alluvial Layer	10YR 3/3 dark brown clay loam
42	10703	0.78-0.96m	Alluvial Layer	7.5YR 2.5/2 very dark brown clay loam
30	10904	1.00	Buried Soil	10YR 3/4 dark yellowish brown sandy clay
31	10904	1.00	Buried Soil	5YR 5/1 grey clay loam
46	10909		Layer	10YR 5/4 yellowish brown clay loam
47	10908		Buried Soil	2.5/2YR very dark brown silty clay loam
48	11109	1.18	Layer	10YR 4/3 brown silty clay loam
49	11102	1.26	Alluvial Layer	10YR 4/2 dark greyish brown silty clay
51	11111	1.44	Alluvial Layer	10YR 4/4 dark yellowish brown silty clay
53	11112	1.68	Natural	10YR 4/2 dark greyish brown silty clay loam
54	11103	1.91	Alluvial Layer	10YR 3/2 very dark greyish brown silty clay loam

Sample	Context	Depth (m BGL)	Feature Type	Soil Description
55	11103	1.91m	Alluvial Layer	10YR 4/2 dark greyish brown silty clay
104	11213	2.50	Alluvial Layer	10YR 3/1 very dark grey silty clay
105	11213	2.6 - 2.7	Alluvial Layer	10YR 3/1 very dark grey silty clay
106	11214	2.8 - 2.9	Alluvial Layer	10YR 3/1 very dark grey silty clay

Table 10: Summary of waterlogged samples

Sample	Context	Sample Vol (L)	Flot Vol (ml)	Date	Wood	Insect	Fruit/Nut	Seeds	Mineralised	Charred	Molluscs	Other	Notes
7	10704	1	400	-		++		+				++	Flot is mainly fine roots with stems/stalks. Stems and stalks form a matt of intertwined plant material. Rare <i>Potamogeton</i> sp., no other seeds in scanned portion. <i>Daphnia</i> ehippia.
30	10904	1	6	-		+++		++		+		++++	Flot is mainly fragments of fine roots/stems/stalks. <i>Daphnia</i> ehippia and bryozoan statoblasts abundant. <i>Ranunculus</i> sub gen <i>Batrachium</i> , and <i>Alisma</i> sp., present. Unidentified fragments of other seeds. Occasional very small charcoal fragments. Insect remains fragmentary but include intact small specimens.
31	10904	1	2	-		++		++		+		+++	Flot is mainly fragments of fine roots/stems/stalks. <i>Daphnia</i> ehippia and bryozoan statoblasts present. <i>Ranunculus</i> sub gen <i>Batrachium</i> , <i>Chenopodium</i> sp., and <i>Alisma</i> sp., present. Insect remains include intact small specimens.
40	10706	1	120	-		+						+	Flot is mainly fragments of fine roots/stems/stalks. <i>Daphnia</i> ehippia.
41	10705	1	100	-		+		+				+	A peaty flot that comprises degraded woody fragments and decayed organic material. Rare stem and root fragments. Single badly damaged <i>Carex</i> sp., in scanned portion. <i>Daphnia</i> ehippia.

Sample	Context	Sample Vol (L)	Flot Vol (ml)	Date	Wood	Insect	Fruit/Nut	Seeds	Mineralised	Charred	Molluscs	Other	Notes
42	10703	1	100	-		+++		++				+	Flot is mainly fragments of fine roots/stems/stalks and decayed organic material. <i>Carex</i> sp., <i>Ranunculus sceleratus</i> . Insect remains highly fragmentary but include small intact specimens. Rare <i>Daphnia</i> ehippia.
43	9403	1	<1	-				++				+	Small flot with fine fragments of peaty material. <i>Carex</i> sp., seeds common. Rare <i>Daphnia</i> ehippia
44	9403	1	40	-		+++		++				++	Flot is mainly small fragments of peaty material. Insect remains highly fragmentary but include small intact specimens. Seeds include <i>Ranunculus</i> sub gen <i>Batrachium</i> , <i>Lemna</i> sp., <i>Eleocharis</i> sp., <i>Carex</i> sp. and <i>Alisma</i> sp. <i>Daphnia</i> ehippia present and bryozoan statoblasts.
45	9407	1	1	-				+		+			Flot is mainly fragments of fine roots/stems/stalks. Occasional very small charcoal fragments. Rare, fragmented seeds.
46	10909	1	4	-		+++		+++		++		++	Flot is mainly fragments of fine roots/stems/stalks. Occasional charcoal fragments. Seeds include <i>Ranunculus</i> sub gen <i>Batrachium</i> , <i>Potamogeton</i> sp., <i>Eleocharis</i> sp., <i>Alisma</i> sp., <i>Carex</i> sp., etc. Insect remains are common but fragmentary. <i>Daphnia</i> ehippia and bryozoan statoblasts.

Sample	Context	Sample Vol (L)	Flot Vol (ml)	Date	Wood	Insect	Fruit/Nut	Seeds	Mineralised	Charred	Molluscs	Other	Notes
47	10908	1	60	-		+++		++				++	Volume of flot is mainly fragments of fine roots/stems/stalks. Seeds include <i>Carex</i> sp., <i>Solanum</i> sp., <i>Alisma</i> sp. Fragmentary insect remains common. <i>Daphnia</i> ehippia and bryozoan statoblasts.
48	11109	1	20	-		+++		+++				+++++	Flot is mainly fragments of fine roots/stems/stalks. <i>Daphnia</i> ehippia and bryozoan statoblasts abundant. Seeds are mainly <i>Carex</i> sp., <i>Ranunculus</i> sub gen <i>Batrachium</i> , <i>Chenopodium</i> sp., and fragments of Apiaceae also present. Insect remains are common but fragmentary.
49	11102	1	40	-		++++		++				+++	Flot is mainly fragments of fine roots/stems/stalks. Damaged Apiaceae, <i>Ranunculus</i> sub gen <i>Batrachium</i> , and <i>Potamogeton</i> sp. Insect remains fragmentary but include occasional small intact specimens. <i>Daphnia</i> ehippia and bryozoan statoblasts.
51	11111	1	35	-	++	++++		+++		+		+++	Flot is mainly fragments of fine roots/stems/stalks. Occasional wood fragments. Seeds include <i>Ranunculus</i> sub gen <i>Batrachium</i> , cf <i>Apium repens</i> , <i>Ranunculus acris/repens/bulbosus</i> , <i>Potamogeton</i> sp., <i>Rumex</i> sp., <i>Carex</i> sp., <i>Chenopodium</i> sp. <i>Daphnia</i> ehippia and bryozoan statoblasts. Insect remains include intact small specimens.

Sample	Context	Sample Vol (L)	Flot Vol (ml)	Date	Wood	Insect	Fruit/Nut	Seeds	Mineralised	Charred	Molluscs	Other	Notes
53	11112	1	100	-		+++		+++				++	Flot is mainly fragments of fine roots/stems/stalks. <i>Juncus</i> sp., <i>Ranunculus</i> sub gen <i>Batrachium</i> , <i>Potamogeton</i> sp., <i>Carex</i> sp., <i>Chenopodium</i> sp. Insect remains are fragmentary but include occasional small intact specimens. <i>Daphnia</i> ephippia and bryozoan statoblasts
54	11103	1	150	-		+++		++++		+		+++	Flot is mainly fragments of fine roots/stems/stalks. Seeds include <i>Ranunculus</i> sub gen <i>Batrachium</i> , <i>Oenanthe</i> sp., <i>Eleocharis</i> sp., <i>Lemna</i> sp., <i>Rumex</i> sp., <i>Carex</i> sp., <i>Potamogeton</i> sp., etc. Insect remains are fragmentary but include occasional small intact specimens. <i>Daphnia</i> ephippia and bryozoan statoblasts.
55	11103	1	75	-		+++		+++				++	Flot is mainly fragments of fine roots/stems/stalks. Seeds include <i>Oenanthe</i> sp., <i>Eleocharis</i> sp., cf <i>Potentilla</i> sp., <i>Urtica dioica</i> , <i>Ranunculus</i> sub gen <i>Batrachium</i> , <i>Carex</i> sp., <i>Chenopodium</i> sp. Insect remains are fragmentary but include occasional small intact specimens. <i>Daphnia</i> ephippia and bryozoan statoblasts
70	1412	1	16	-						++			Flot is mainly fragments of fine roots/stems/stalks some with a modern appearance. Small flecks and

Sample	Context	Sample Vol (L)	Flot Vol (ml)	Date	Wood	Insect	Fruit/Nut	Seeds	Mineralised	Charred	Molluscs	Other	Notes
													occasional larger charcoal fragments, mainly <2mm.
71	1414	1	3	-						+			Flot is mainly fragments of fine roots/stems/stalks. Small flecks of charred plant remains.
72	1414	1	20	-		++++						+++	Flot is mainly fragments of fine roots/stems/stalks and clay nodules. Insect remains include intact small specimens. <i>Daphnia</i> ephippia and bryozoan statoblasts.
73	1415	1	8	-		+++		+++				+++	Flot is mainly fragments of fine roots/stems/stalks. <i>Oenanthe</i> sp., seeds common, also <i>Eleocharis</i> sp., <i>Ranunculus</i> sub gen <i>Batrachium</i> , and <i>Carex</i> sp. Insect remains are common but fragmentary. <i>Daphnia</i> ephippia and bryozoan statoblasts present.
74	1415	1	20	-		++		++++				+++	Flot is mainly fine roots and stems/stalks. Seeds include <i>Eleocharis</i> sp., <i>Carex</i> sp. cf <i>Alisma</i> sp., <i>Oenanthe</i> sp., Poaceae cf <i>Lolium multiflorum</i> , and <i>Ranunculus</i> sub gen <i>Batrachium</i> . Insect remains are fragmentary. <i>Daphnia</i> ephippia and bryozoan statoblasts present.
75	1416	1	30	-		++		+++				+++	Flot is mainly fine roots and stems/stalks. Seeds include Poaceae, <i>Alisma</i> sp., <i>Juncus</i> sp., <i>Ranunculus</i> sub gen <i>Batrachium</i> , <i>Ranunculus sceleratus</i> , cf <i>Artemisia</i> sp. <i>Eleocharis</i> sp., Insect remains are fragmentary

Sample	Context	Sample Vol (L)	Flot Vol (ml)	Date	Wood	Insect	Fruit/Nut	Seeds	Mineralised	Charred	Molluscs	Other	Notes
													but include occasional small intact specimens. <i>Daphnia</i> ehippia and bryozoan statoblasts.
76	1417	1	4	-						++			Flot is mainly fine roots and stems/stalks. Small flecks of charred plant remains with occasional charcoal fragments >2mm.
77	1418	1	3	-		+				+		++	Flot is mainly fine roots and stems/stalks. Small flecks of charred plant remains. <i>Daphnia</i> ehippia
78	1424	1	3	-						+++			Flot is mainly fragments of fine roots/stems/stalks. Small flecks of charred plant remains with occasional charcoal fragments >2mm.
79	1425	1	4	-				+					Flot is mainly fragments of fine roots/stems/stalks. <i>Juncus</i> sp.
85	10210	1	260	-		+++		++				++	Flot is mainly fragments of fine roots/stems/stalks. Seeds include <i>Alisma</i> sp., <i>Potamogeton</i> sp., <i>Lycopus europaeus</i> , <i>Carex</i> sp. Insect remains are fragmentary. <i>Daphnia</i> ehippia present.
86	10211	1	60	-		++++		+++				+++	Flot is mainly fragments of fine roots/stems/stalks. Seeds include <i>Ranunculus</i> sub gen <i>Batrachium</i> , <i>Chenopodium</i> sp., <i>Lemna</i> sp., <i>Carex</i> sp., <i>Potamogeton</i> sp. Insect remains include intact small specimens. <i>Daphnia</i> ehippia and bryozoan statoblasts present.

Sample	Context	Sample Vol (L)	Flot Vol (ml)	Date	Wood	Insect	Fruit/Nut	Seeds	Mineralised	Charred	Molluscs	Other	Notes
104	11213	1	150	-		+++		+++				++	Flot is mainly fine roots and large numbers of stems/stalks. Seeds include <i>Carex</i> sp. cf <i>Alisma</i> sp., <i>Ranunculus</i> sub gen <i>Batrachium</i> , <i>Potamogeton</i> sp., <i>Persicaria</i> sp. Insect remains include intact small specimens and occasional beetle elytra. <i>Daphnia</i> ephippia and bryozoan statoblasts..
105	11213	1	300	-		+++		+++				++	Flot is mainly fragmented roots/stems/stalks. Seeds include <i>Carex</i> sp., <i>Alisma</i> sp., <i>Oenanthe</i> sp., Insect remains include intact small specimens. Occasional <i>Daphnia</i> ephippia and bryozoan statoblasts.
106	11214	1	40	-	+	+		+		++			Flot is mainly fragmented roots/stems/stalks. Small flecks of charcoal, mainly <2mm. Occasional soft woody fragments. <i>Alisma</i> sp. Insect remains are fragmentary.
107	9403	1	40	-		++++		++				++	Flot is mainly fragments of fine roots/stems/stalks. Seeds include <i>Carex</i> sp., <i>Potamogeton</i> sp., <i>Oenanthe</i> sp., and <i>Alisma</i> sp. Insect remains include intact small specimens and occasional beetle elytra. <i>Daphnia</i> ephippia and bryozoan statoblasts.
109	9411	1	20	-		++		++		++			Flot is mainly fragments of fine roots/stems/stalks. Small flecks and occasional larger charcoal fragments, mainly <2mm. <i>Alisma</i> sp., <i>Rubus</i> sp.,

Sample	Context	Sample Vol (L)	Flot Vol (ml)	Date	Wood	Insect	Fruit/Nut	Seeds	Mineralised	Charred	Molluscs	Other	Notes
													<i>Ranunculus</i> sub gen <i>Batrachium</i> . Insect remains are fragmentary.
120	9726	1	200	-	+	+++		+++				+	Flot is mainly fragments of fine roots with stems/stalks. Seeds include <i>Eleocharis</i> sp., <i>Alisma</i> sp., <i>Ranunculus</i> sub gen <i>Batrachium</i> , <i>Oenanthe</i> sp., <i>Rubus</i> sp., <i>Carex</i> sp., <i>Potamogeton</i> sp. Insect remains include intact small specimens and fragments of elytra. Occasional <i>Daphnia</i> ephippia and bryozoan statoblasts.
121	9727	1	275	-		+++		++				++	Flot is mainly fragments of fine roots with stems/stalks. Seeds include <i>Potamogeton</i> sp., <i>Eleocharis</i> sp., <i>Lycopus europaeus</i> , <i>Oenanthe</i> sp., Insect remains include intact small specimens and fragments of elytra. Occasional <i>Daphnia</i> ephippia and bryozoan statoblasts present. Occasional caddisfly larvae cases.
122	9728	1	175	-		+++		+++				++	Flot is mainly fragments of fine roots and stems/stalks. Seeds include <i>Potamogeton</i> sp., <i>Oenanthe</i> sp., <i>Carex</i> sp., <i>Lycopus europaeus</i> , <i>Chenopodium</i> sp., <i>Lemna</i> sp. Insect remains include intact small specimens and fragments of elytra. Occasional <i>Daphnia</i> ephippia and bryozoan statoblasts present. Occasional caddisfly larvae cases.

Sample	Context	Sample Vol (L)	Flot Vol (ml)	Date	Wood	Insect	Fruit/Nut	Seeds	Mineralised	Charred	Molluscs	Other	Notes
123	9729	1	150	-	++	+++		+++		+		++	Flot is mainly fragments of fine roots with stems/stalks. Occasional large wood fragments in good condition. Charcoal fragments, mainly <2mm. Seeds include <i>Carex</i> sp., cf <i>Artemisia</i> sp., <i>Alisma</i> sp., <i>Potamogeton</i> sp., <i>Oenanthe</i> sp., <i>Lycopus europaeus</i> . Insect remains include intact small specimens and fragments of elytra. Occasional <i>Daphnia</i> ephippia and bryozoan statoblasts.
135	7304	1	1	-	+					+			Flot is mainly fragments of fine roots/stems/stalks. Small flecks and occasional larger charcoal fragments, mainly <2mm.
162	702	1	4	-									Occasional fragments of fine roots/stems/stalks. Small fragments of humic material. Occasional <i>Daphnia</i> ephippia and bryozoan statoblasts.
163	703	1	3	-		+							Occasional fragments of fine roots/stems/stalks. Small fragments which may be from <i>Juncus</i> seeds. Small fragments of humic material. Rare insects including elytra fragments.
164	704	1	3	-		+							Small fragments of humic material with occasional fragments of fine roots/stems/stalks. Rare insect fragments.
165	705	1	15	-	+	++++							Flot is mainly fragments of fine roots with stems/stalks and small fragments of humic material with a peaty

Sample	Context	Sample Vol (L)	Flot Vol (ml)	Date	Wood	Insect	Fruit/Nut	Seeds	Mineralised	Charred	Molluscs	Other	Notes
													appearance. Rare wood fragments, soft and fragile. Insect remains common but fragmentary.
166	706	1	18	-	+	++++		++				++	Flot is mainly fragments of fine roots/stems/stalks. Fragments of humic material with a peaty appearance. Rare degraded wood fragments. <i>Alisma</i> sp., <i>Rubus</i> sp., <i>Lycopus europaeus</i> . Insect remains common includes elytra in intact condition. Occasional <i>Daphnia</i> ehippia and bryozoan statoblasts.
167	713	1	70	-	+	++++		+++				++	Volume of flot is mainly fragments of fine roots/stems/stalks. Rare degraded wood fragments. <i>Alisma</i> sp., <i>Oenanthe</i> sp., <i>Carex</i> sp., <i>Ranunculus</i> sub gen <i>Batrachium</i> , <i>Chenopodium</i> sp., <i>Eleocharis</i> sp. Insect remains common and in good condition; includes elytra and other parts. Occasional <i>Daphnia</i> ehippia and bryozoan statoblasts.
168	714	1	35	-	+	++++		+++				+++	Volume of flot is mainly fragments of fine roots/stems/stalks. Rare wood fragments, soft and fragile. <i>Alisma</i> sp., <i>Ranunculus</i> sub gen <i>Batrachium</i> , <i>Potamogeton</i> sp., <i>Oenanthe</i> sp., <i>Rumex</i> sp., <i>Carex</i> sp., <i>Eleocharis</i> sp. Insect remains common and well preserved,; includes elytra. <i>Daphnia</i> ehippia and bryozoan statoblasts. Caddisfly cases.

Sample	Context	Sample Vol (L)	Flot Vol (ml)	Date	Wood	Insect	Fruit/Nut	Seeds	Mineralised	Charred	Molluscs	Other	Notes
169	715	1	60	-	+	+++		++++				+++	Flot volume mainly fragments of fine roots/stems/stalks. Rare degraded wood fragments. <i>Rumex</i> sp., <i>Oenanthe</i> sp., <i>Eleocharis</i> sp., <i>Ranunculus</i> sub gen <i>Batrachium</i> , <i>Potamogeton</i> sp., <i>Carex</i> sp., <i>Alisma</i> sp., cf <i>Artemisia</i> sp. etc. Insect remains common includes elytra. Occasional <i>Daphnia</i> ephippia and bryozoan statoblasts.
170	716	1	20	-		++		++				++	Flot mainly fragments of fine roots/stems/stalks. Small flecks and occasional larger charcoal fragments, mainly <2mm. <i>Alisma</i> sp., <i>Ranunculus</i> sub gen <i>Batrachium</i> , <i>Eleocharis</i> sp., <i>Potamogeton</i> sp. Insect remains include rare intact small specimens and fragments of elytra. Occasional <i>Daphnia</i> ephippia and bryozoan statoblasts present.
171	717	1	6	-		+		+		+			Flot is mainly fragments of fine roots/stems/stalks. Small flecks and occasional larger charcoal fragments, mainly <2mm. <i>Ranunculus</i> sub gen <i>Batrachium</i> . Rare small insect fragments.
172	718	1	3	-						+			Flot is mainly fragments of fine roots/stems/stalks. Small flecks and occasional larger charcoal fragments, mainly <2mm.
173	719	1	3	-									Fragments of fine roots/stems/stalks only.

Sample	Context	Sample Vol (L)	Flot Vol (ml)	Date	Wood	Insect	Fruit/Nut	Seeds	Mineralised	Charred	Molluscs	Other	Notes
179	1608	1	15	-		++++		++++				+++	Flot is mainly fragments of fine roots/stems/stalks. Seeds include <i>Potamogeton</i> sp., <i>Alisma</i> sp., <i>Ranunculus</i> sub gen <i>Batrachium</i> , <i>Eleocharis</i> sp. <i>Rubus</i> sp., <i>Carex</i> sp. Insect remains include intact small specimens and beetle elytra. Occasional <i>Daphnia</i> ephippia and bryozoan statoblasts.
180	1609	1	5	-		+		+		+			Flot is mainly fragments of fine roots/stems/stalks. Small flecks and occasional larger charcoal fragments, mainly <2mm. <i>Eleocharis</i> sp.
181	1610	1	2	-		+							Volume of flot is mainly fragments of fine roots/stems/stalks. Fungal sclerotia common.
Key: + 1-4, ++ 5-24, +++ 25-49, ++++ 50-99, +++++ 100+													

Table 11: The waterlogged flots

Waterlogged plant remains from borehole samples

- C.2.29 In addition to the bulk samples, samples were taken from a series of boreholes that were drilled in three transects across the site. Following the logging of these boreholes a series of subsamples were taken for pollen, ostracod, and diatoms as well as waterlogged plant remains. Of these, seven subsamples were taken primarily for the retrieval and assessment of plant materials and to provide materials suitable for radiocarbon dating. Subsamples of sediment were also taken from several monoliths to provide macrofossils for radiocarbon dating if possible. Not all of the subsamples produced identifiable macrofossils and only those which did are reported here. The subsamples were also assessed for the presence of charcoal and other paleoenvironmental indicators.
- C.2.30 The borehole samples all come from Borehole Transects 4 and 5. Transect 4 covers two palaeochannels with fills present in BH405A and BH414A.
- C.2.31 This assessment aims to evaluate the diversity and quantity of species present together with the degree of preservation of the assemblage.

Method

- C.2.32 The subsamples varied in size from 0.4 to 1 litre with sample volumes given in Table 12. Each sample was processed at Oxford Archaeology using the wash over method. Details of the method and the reference sources for identifications are the same as those for the waterlogged plant remains from bulk samples (see above).

Results

- C.2.33 The results of the assessment are given in Table 12.
- C.2.34 **Monolith 10.** A single subsample was taken from monolith 10, which was taken in Trench 1070 at 55-0.63m BGL. The sample produced only a small quantity of plant remains which largely comprised fine, poorly preserved seed coat fragments which appear to be from bulrushes (*Typha* sp.), as well as small fragments of stem/stalk.
- C.2.35 **WS405A.** The three subsamples from borehole WS405A, located slightly south of Trench 94, produced large flots which comprised largely stalk/stem fragments with some fine roots and no residues. The samples are dominated by sedges (*Carex* sp.), pondweed (*Potamogeton* sp.), spike-rushes (*Eleocharis* sp.) water plantain (*Alisma plantago-aquatica*) and water crowfoot (*Ranunculus* sub genus *Batrachium*). Seeds from plants found in a wider range of habitats include bramble (*Rubus* sp.) and goosefoots (*Chenopodium* sp.), which were present in much smaller numbers than the more ubiquitous wetland species and are in some cases represented by single seeds. Duckweed (*Lemna* sp.) is present within the lower context.
- C.2.36 **1.40-1.45m:** fragments of stem/stalk and fine roots form most of the flot volume as well as a few degraded fragments of wood. Sedges (*Carex* sp.) dominate the assemblage with most other species represented by small numbers of seeds. The flot also includes occasional fragmented insect remains. Water flea (*Daphnia* sp.) ephippia are present but are not common, indicating the presence of at least semi-permanent water. Seeds extracted from 1.40-1.45m produced a calibrated date of 930-810 cal. BC.
- C.2.37 **2.28-2.33:** flot volume mostly comprises stems/stalks and some fine roots which are less fragmented than those within the upper subsample. The assemblage is more

diverse and includes water crowfoot (*Ranunculus* subgenus *Batrachium*), water plantain (*Alisma plantago-aquatica*), water-dropwort (*Oenanthe aquatica*) and spike rushes (*Eleocharis* sp.), all indicative of a wetland habitat. Insect remains are common but are mostly fragmented. Caddisfly larval cases are present although none are intact. Both the plant taxa and the presence of caddisfly confirm that this is at least a semi-permanent aquatic environment.

- C.2.38 **2.56-2.61**: the small flot is composed of fine roots, stems and stalks as well as seeds from the same species as the sub-sample from 2.28-2.33 although in lower quantities. Pond weed (*Potamogeton* sp.) is more frequent which may indicate more permanent standing water. Insect remains are fragmentary and caddisfly larval cases are present. Seeds extracted from 2.56-2.61m produced a calibrated date of 1510-1400 cal. BC.
- C.2.39 **WS414A**. The two subsamples from borehole WS414A, slightly north of Trench 109, produced moderate sized flots with a 'peaty' appearance.
- C.2.40 **1.43-1.48**: Fragmented peaty material with occasional stem/stalk fragments. A small seed assemblage comprising mainly mints (*Mentha* sp.), sedges and water dropwort. Insect remains are fragmentary and the presence of *Daphnia ephippia* indicate a potentially fluctuating water table. Seeds extracted from 1.43-1.48m produced a calibrated date of 910-800 cal. BC.
- C.2.41 **2.62-2.67** Smaller than the upper subsample, the flot is also peaty with some stem and stalk fragments. The seeds are numerically dominated by water crowfoot, although rushes (*Juncus* sp.) and spike rushes are also well represented. Rare fragments which appear to be charcoal are mainly <2mm. Small fragments of degraded wood are also present. Insect remains are fragmentary and there are also occasional caddisfly larval cases.
- C.2.42 **WS503A**. The two subsamples from borehole WS503A to the west of Trench 14 produced moderate-sized flots rich in largely stalk/stem fragments with some fine roots. Fragmented seed remains are common and have not been quantified for this report due to their poor condition.
- C.2.43 **1.50-1.55**: Again the seeds are dominated by water crowfoot, although water plantains (Alismataceae), sedges, pondweed and water dropwort are also well represented. Insect remains are common but mostly fragmentary, although a few small intact specimens are present. *Daphnia ephippia* and bryozoan statoblasts indicate the likelihood of a variable water table. Caddisfly larval cases are also present and are typical of wetland environments. Seeds extracted from 1.50-1.55m produced a calibrated date of 710-540 cal. BC.
- C.2.44 **3.08-3.13**: The seed assemblage is dominated by water plantains and water crowfoot. Rushes, pondweed, and water dropwort are also well represented. Fragmentary Insect remains and caddisfly larval cases are again present together with *Daphnia ephippia* and bryozoan statoblasts. Occasional wood fragments are small, decayed and fragile. Seeds extracted from 3.08-3.13m produced a date of 1310-1120 cal. BC.

Discussion

- C.2.45 As with those samples within the bulk WPR (reported separately) there is good overall preservation of waterlogged plant remains and insect remains in the more peaty deposits, although the insect remains are typically fragmentary.

- C.2.46 Most of the seeds are from plants which are found in marshy areas, in slow moving or standing water or on the banks of rivers, streams, ponds and ditches. These include water crowfoot, spike rushes, sedges, water-dropwort, gypsywort, water plantain and, in some of the deeper samples, pondweed. These species are usually associated with a freshwater environment: there is no indication of saltmarsh in any of the samples. Water dropwort is often associated with seasonal alterations in water levels (Stace 2010, 816) and the number of these seems to coincide with the presence of ephyppia of *Daphnia*, themselves frequently an indicator of fluctuating water levels.
- C.2.47 Seeds of rushes (*Juncus* sp.) and bulrushes (*Typha* sp.) are present in small numbers; however, it is likely that their presence has been under-estimated due to the difficulty of observing such small seeds within the stem/stalk rich flots.
- C.2.48 The presence of water flea (*Daphnia* sp.) ephyppia together with bryozoan statoblasts within many of the flots has been discussed previously (also see WPR report) and together with the caddisfly larval cases indicate regular inundation of the site, although the ephyppia would indicate that there was variability in conditions through the prehistoric periods represented by these samples.
- C.2.49 Snails were not present in any of the flots which may indicate that the deposits were slightly acidic, which is commonly the case in peaty deposits.

Statement of further potential

- C.2.50 The current work on the WPR borehole samples has identified the range of taxa present and fully quantified them. As such further work is unlikely to add much to the ability to understand these deposits, and no further work is recommended on these samples. The waterlogged flots and residues have been retained wet, but this is not sufficient for storage over the long term, and it is recommended that these are discarded once all work has been completed.

	Sample	Monolith 10	WS405A	WS405A	WS405A	WS414A	WS414A	WS503A	WS503A
	Depth (m) BGL	0.55-0.63	1.40-1.45	2.28-2.33	2.56-2.61	1.43-1.48	2.62-2.67	1.50-1.55	3.08-3.13
	Sample Vol (L)	0.4	0.4	0.4	1	0.4	1	0.45	0.45
	Flot Vol (ml)	1ml	80ml	75ml	40ml	25ml	10ml	25ml	30ml
Plants of waste, cultivated or open ground									
<i>Urtica dioica</i> L.	common nettle	seed					2		1
<i>Stellaria media</i> (L.) Vill.	common chickweed	seed							1
<i>Solanum nigrum</i> L.	black nightshade	seed		1	1				
Wet ground and aquatic plants									
<i>Ranunculus</i> subgenus <i>Batrachium</i>	water crowfoot	seed		74	54		113	73	99
<i>Montia fontana</i> L.	blinks	seed		1			1		
<i>Lycopus europaeus</i> L.	gypsywort	seed	8	2		6		2	8
<i>Oenanthe aquatica</i>	water-dropwort	seed	1	82	4	12		20	17
cf Alismataceae	water-plantain family	seed						9	
<i>Alisma plantago- aquatica</i> L.	water-plantain	seed	3	104	35	10		6	120
<i>Sagittaria</i> sp.	arrowheads	seed		2				10	23
<i>Lemna</i> sp.	duckweed	seed		1	2		12	2	5
<i>Potamogeton</i> sp.	pondweed	seed	2	15	20		1	22	22
<i>Sparganium</i> sp.	bur-reed	fruit	3						
<i>Typha</i> sp.	bulrush	seed	+++	1	1	1			
<i>Juncus</i> sp.	rush	seed		2		11		20+	20+
<i>Eleocharis palustris</i>	common spike- rush	seed			68	27		11	7
<i>Eleocharis</i> sp.	spike-rush	seed		2	37	26		17	4
Cyperaceae	sedge family	Seed in utricle			14	5			32
<i>Carex</i> sp.	sedge	seed (small)		9			1		1
<i>Carex</i> sp.	sedge	seed		163	5	14	32	1	29
<i>Carex</i> sp.	sedge family	seed (2 sided)		1	10	2			1
Plants from broad ecological groupings									

	Sample		Monolith 10	WS405A	WS405A	WS405A	WS414A	WS414A	WS503A	WS503A
	Depth (m) BGL		0.55-0.63	1.40-1.45	2.28-2.33	2.56-2.61	1.43-1.48	2.62-2.67	1.50-1.55	3.08-3.13
	Sample Vol (L)		0.4	0.4	0.4	1	0.4	1	0.45	0.45
	Flot Vol (ml)		1ml	80ml	75ml	40ml	25ml	10ml	25ml	30ml
<i>Ranunculus acris/repens/bulbosus</i>	meadow/creepin g/ bulbous buttercup	seed			2	2	2			4
<i>Rubus</i> sp.	bramble	seed			5					3
<i>Potentilla</i> sp.	cinquefoils	seed								
<i>Rumex</i> sp.	dock	seed							2	3
<i>Rumex</i> sp.	dock	seed with perianth							1	
<i>Stellaria graminea</i> L.	lesser stitchwort	seed			1					
<i>Chenopodium</i> sp.	goosefoots	seed		1	7	20		1	1	3
cf <i>Atriplex</i> sp.	orache	seed			1					
<i>Mentha</i> sp.	mint	seed		8		2	31			1
<i>Crepis</i> sp.	hawks-beard	seed			1					
Apiaceae	carrot family	seed					6			10
Poaceae	grass (medium)	seed coat only		2					5	
Indet		seed		3	2		2			3
Additional data										
Wood								+		+
Insect remains				++	+++	++	++	++	+++	++++
Charred material								++		
<i>Daphnia</i> ephippia				+			+		+	+
Bryzoan statoblast									+	+
Caddisfly larval cases					+	+		+	+	+
Key: + 0-4, ++ 5-24, +++ 25-49, ++++ 50-99, +++++ 100+										

Table 12: The waterlogged plant assemblages from borehole samples

C.3 Animal Bone

By Adrienne Powell

- C.3.1 A complete left radius (201g) from a red deer (*Cervus elaphus*) was recovered from context 10904 in Trench 109. The specimen is fused at both ends and has the greatest length of 289mm, other measurements could not be taken due to mineral concretions at either end and extensive exfoliation of the cortical surface.
- C.3.2 The 10-4mm residue from sample 143, context 1312, produced over 100 comminuted, calcined fragments of indeterminate mammal bone (20g).

Recommendations regarding the conservation, discard and retention of material

- C.3.3 Although the condition of the red deer specimen is only moderate it has potential for use in future biomolecular analyses of British red deer populations and should be retained. The calcined bone should be retained until the completion of the project then may be discarded.

C.4 Human Remains

By Annsofie Witkin

Introduction and provenance

- C.4.1 This report details the findings of an osteological analysis of two unurned cremation deposits (606 and 9008), recovered from the floodplain of the Mar Dyke Valley. Deposit 606 was from a shallow sub-rounded pit 605, located in Trench 6. The pit measured 0.50m x 0.46m and it was 0.12m deep. Deposit 9008 was found in Trench 90 and was also recovered from a sub-circular pit (9007) that was 0.36m in diameter and 0.07m deep. Both features had been truncated by the machine excavating the trenches. There is no direct dating evidence associated with the cremated bone deposits.
- C.4.2 Other archaeological features recorded from this area comprised a line of waterlogged wooden piles which dated to the late Bronze Age/early Iron Age in Trench 14. In addition, one further deposit of burnt bone was recovered from cut 1311, but is probably animal bone. The feature, which was 0.30m in diameter and 0.18m deep with steep sides, a flat base and a fill comprising friable dark brown black silt, was interpreted as a posthole. The residue from sample <143> was found to contain a large amount of charcoal and 20.8g of burnt bone which was all uniformly white and calcined. The remains did not include any fragments that could be positively identified as human. One fragment was morphologically consistent with animal and further fragments had surviving trabecular structure strongly suggesting animal remains. This deposit was therefore not considered to comprise human cremated remains and will not form part of this report.

Methodology

- C.4.3 The cremation deposits were recovered, processed and analysed in accordance with published guidelines (McKinley 2004). The deposits were subjected to whole earth recovery and pit (605) was excavated in three spits of 0.04m each to the combined depth of 0.12m (Table 13).
- C.4.4 The individual sample numbers were wet sieved and sorted into >10mm, 10-4mm, 2-4mm and <2mm fraction sizes. The burnt bones were subsequently removed from the extraneous material. A proportion of the 4-2mm fraction size was sorted and a percentage bone weight was calculated which was applied to the total weight of the unsorted material (Table 14). This provided an informed bone weight estimation for the fraction size (Table 15). The smallest fraction sizes from each sample (2-0.5mm) were not sorted but were rapidly scanned for identifiable skeletal remains and artefacts. Estimations of the proportions of bone present within the 2-0.5mm fractions were made visually (Table 16).
- C.4.5 All bone was analysed to record colour, weight and maximum fragment size. Each of the sieve fractions was examined for identifiable bone elements. The minimum number of individuals was determined by the identification of repeated elements and the presence of both juvenile and adult bones within the same context.

Feature	Context	Sample	Description	Soil/deposit type	Deposit Depth
605	606	96	Spit 1	Dark grey-black silty and with frequent charcoal and white flecks	0.12m
		101	Spit 2		
		102	Spit 3		
9007	9008	57	Primary fill	Dark grey-black silty sand with frequent charcoal and occasional white flecks	0.07m

Table 13: Summary of the cremation deposits

Results

C.4.6 A summary of the results from the osteological analysis is presented in Table 14.

Feature	>10mm	10-4mm	4-2mm	Total weight	Maximum fragment size (mm)	Identified elements	Colour	MNI, age, sex, pathology etc.
605	0g 0%	7.70g 12.80%	52.50g 87.20% Est.	60.20g 100%	16.05	Cranial vault fragment	White 90% Grey 10%	MNI = 1 Sex unknown Age probable adult
9008	0g 0%	4.8g 29.10%	10.50g 70.90% Est.	14.80g 100%	13.55	None	White 100%	MNI = 1 Sex unknown Age Unknown

Table 14: Summary of osteological findings: Cremation deposits

Bone weights

C.4.7 The bone weights were very low at a total of 60.2g for deposit 606 and 14.8g for deposit 9008. They are a fraction of the expected bone weight from a modern cremation which is on average 1650g (McKinley 2000, 269). They are also much lower than the expected weight of archaeologically recovered cremation deposits (between 600 and 900g; Mckinley 2013, 154).

Feature	Sample	Total Weight of unsorted fraction 4-2mm A	Weight of bone in a 20g sample B	% of bone weight calculated (B/20 x 100) C	Estimated weight of cremated bone in unsorted fraction (C/100 x A)
605	96	26.0g	7.5g	37.5%	9.75g
	101	69.9g	11.9g	59.5%	41.59g
9007	57	161g	1.3g	6.5%	10.5g

Table 15: Bone weight calculations for the unsorted 2-4mm fractions

Fragmentation

C.4.8 Both deposits were highly fragmented with the greatest percentage of bone (more than half of the bone) being within the 4-2 mm sieve fraction (Table 14). No bones were recovered from the over 10mm sieve fraction and less than 30% was from the 4-10 mm fraction.

C.4.9 The extent of fragmentation can be influenced by several factors. This includes the cremation process itself which causes fissuring and cracking from the heat; collection

of the bones from the cremation pyre; possible manipulation of the remains prior to the burial itself; the type of burial vessel used (e.g., organic versus ceramic) the process of burying the remains; subsequent post-burial disturbance such as ploughing and the excavation and processing the remains prior to analysis (McKinley, 1994).

- C.4.10 In addition, the bone from deposit 9008 was abraded indicating that it had been exposed to bioturbation, which is likely to be due to the deposit being located on a floodplain.

Feature	Context	Sample	Total weight unsorted <2mm	Bone content (high/moderate/low)	Estimated % bone content (by volume)
605	606	96	280g	Low	<1%
605	606	101	530g	Low	5%
605	606	102	15.5g	Low	<1%
9007	9008	57	487g	Low	<1%

Table 16: Summary of the unsorted <2mm fractions

Skeletal representation

- C.4.11 Due to the high level of fragmentation, only one cranial vault fragment was identified. This was from deposit 606 and represented 0.3% of the total weight of the deposits, which is very low. That the fragment was identified is due to unique structure of the cranial vault which facilitates the ease of the recognition of this skeletal region.

Colour of the cremated bone

- C.4.12 The majority of the fragments were uniformly white, while a small proportion of fragments were grey and greyish white. The colour of cremated bone denotes the efficiency of the cremation process itself. This is influenced by the quality and the quantity of the fuel used, the duration of the cremation process itself and the temperature attained during the cremation (McKinley 2004, 11). The white colour indicates that the bones were fully oxidised, and this occurs at temperatures exceeding 600 °C.

Demography and pathology

- C.4.13 There were no repeated bone present in either of the cremated bone deposits. Additionally, neither contained any burnt bone that suggested the deposits comprised fragments from both subadult and adult remains. This indicated that each deposit contained the Minimum Number of Individuals (MNI) of one per deposit.
- C.4.14 The thickness of the cranial vault fragment from deposit 605 suggests that this was an adult individual. None of the fragments either of the deposits had any diagnostic criteria present for estimating sex. No pathological lesions were observed.
- C.4.15 It is concluded that the cremation deposits represent two individuals of unknown sex and at least one of these individuals is likely to be an adult.

Discussion

- C.4.16 Although cremated bone submitted from deposit 606 proved to be too unevenly cremated to provide a radiocarbon date, roundwood twiggy charcoal from the

surrounding deposit was submitted for dating, and provided a date range of 1100-900 cal BC (Beta-613902; 2830 ± 30 BP). A cremation burial excavated in Land Parcel 46 to the north of the site, from the fill of ditch 46007 in Trench 460, was also provided a similar date by its association with late Bronze Age/early Iron Age pottery. Compared with deposits 606 and 9008, this cremation was slightly larger (total weight = 79.2g), and it contained larger and more identifiable bone fragments (OCA 2022a).

- C.4.17 The bone weights of deposits 606 and 9008 are significantly below the expected bone weight range of 600-900g usually reported for archaeologically recovered cremation burials (McKinley 20013, 154). Deposits of low weight are not an uncommon occurrence in archaeological contexts from prehistoric sites and these have been termed cremation-related deposits. (McKinley 2000, 41) These comprise a token amount of bone only – cenotaph burial, or redeposited pyre debris, which comprises a mixture of bone fragments and fuel waste (McKinley 2004,10). The present cremation deposits contained frequent charcoal and may therefore represent pyre debris.
- C.4.18 Cremation was the dominant funerary ritual during the late Bronze Age, and small quantities of burnt bone or token cremation deposits are not uncommon from this period; the deliberate fragmentation and internment of a representative amount of bone is a recognised funerary practice (Brück, 2017). Cremation deposits were often associated with settlements (ibid), although this is not obviously the case here.
- C.4.19 Though it is not possible to ascertain how much of the burnt bone deposits have been lost due to past activities, and how representative these are of the original deposits, the frequent charcoal within them excludes the possibility that these were formal cremation burials or cenotaphs. Moreover, the deposits were not located within a settlement. It is therefore concluded that the cremated bone deposits are redeposited pyre debris.
- C.4.20 The assemblage is currently held at Oxford Archaeology under Ministry of Justice burial licence 19-0317. This licence is valid until 08 December 2025, by which time the remains must have been reburied. In the event that the remains are not ready for reburial by this time the licence should be deferred by application to the Ministry of Justice.

C.5 Radiocarbon Dating

by Rebecca Nicholson

Introduction

- C.5.1 Twenty samples were dated by Accelerator Mass Spectrometry (AMS) at the Beta Analytic radiocarbon dating laboratory. Eighteen of the samples comprised either waterlogged seeds from a range of taxa excluding aquatics (although inevitably comprising plants of damp places such as sedge: *Carex* sp.) or were samples of peaty sediment. The latter were submitted for both the humic (alkali soluble) and humin (alkali insoluble) fractions to be dated, so for the six submitted samples of bulk peat or organic silt, twelve radiocarbon determinations were obtained. Contexts and depths (in mm) from the top of the respective monoliths or cores are given in Table 17. Additionally, a sample of the outermost available rings of an oak (*Quercus* sp.) wooden post or stake (1422) and a fragment of Maloideae charcoal from sample < 96 > (606) were also submitted and dated.
- C.5.2 The aim of dating the organic sediments was to clarify the sequence of deposits in the valley sequence from sediments that failed to produce sufficient seeds or other short-lived datable material. Since the deposits were mostly organic sediments rather than true peat both the humic and humin fractions were dated independently since the sources of the carbon could be complex. In dynamic environments such as channel fills the alkali soluble (humic) fraction may migrate due to water movement, and this can also lead to erroneous dating, typically a younger than expected date, while the alkali insoluble (humin) fraction may be affected by the incorporation of old carbon, for example from redeposited charcoal, or reflect minor amounts of contamination due to natural carbon migration within the sedimentary profile.
- C.5.3 The reported results are conventional radiocarbon ages (Stuiver and Polach 1977) and were corrected for total fractionation effects and calibration was performed using OxCal 4.4.4 and INTCAL20 (Bronk Ramsey 2009 with 2021 update, Reimer *et al.* 2020). They are presented in Table 17 below with the end points rounded outwards to 10 years following the recommendations of the 1977 International Radiocarbon conference. Reported results are accredited to ISO/IEC 17025:2005 Testing Accreditation PJLA #59423 standards and all chemistry was performed in the Beta Analytic laboratory. When counting statistics produce sigmas lower than +/- 30 years, a conservative +/- 30 BP has been cited for the result. The reported $\delta^{13}\text{C}$ values were measured separately in an IRMS (isotope ratio mass spectrometer) and are not the AMS $\delta^{13}\text{C}$ which would include fractionation effects from natural, chemistry and AMS induced sources.
- C.5.4 The reliability of the dates obtained from the peat and organic sediment were tested using a χ^2 test on the paired samples (see Tables 18-23). Measurements on both fractions proved to be statistically inconsistent in all cases (Ward and Wilson 1978), so while a weighted mean value has been calculated for each pair using the R_combine facility in OxCal prior to calibration, the combined date has to be viewed with caution and the full range of both fractions is a more reliable measure.
- C.5.5 The results from monolith <10> at 0.11-0.12m are extremely inconsistent, with the humin fraction providing a late Iron Age determination and the humic fraction a Saxon determination. It is worth noting that the submitted sample proved to contain a very

low quantity of alkali soluble organics and additional 43g of sediment was required in order to produce the final result. It is unclear which fraction has produced the more reliable date. The sample from a dark lens of material in Transect 3 borehole OCA-WS-307 at 2.38-2.39m also produced an inconsistent result, in this case the humic fraction gave an early Holocene determination while the humin fraction provided a late Glacial date. While the true age of the organic lens can not be established with certainty, it may be significant that the pair of dates are similar to those obtained from a dark lens within pale soil at the base of the valley at Site 12, where again the deposit is likely to be either early Holocene or late Glacial, or reflect a period of transition, although an earlier date cannot be ruled out.

- C.5.6 Sediment The inconsistent dates provided by the sediment samples means that wherever possible organic deposits in this area should be dated from plant macrofossils rather than the sediments themselves.

Lab. reference	Sample	Context	Depth from top of monolith/core	Depth BGL	Material	Fraction dated	$\delta^{13}\text{C}$ (‰)	Radiocarbon Age (BP)	Calibrated date BC/AD (at 95.4%)
Beta-617533	LTC43M21 OCA-WS-307		2.38-2.39m	2.38-2.39m	Organic sediment	alkali soluble	-28.4	9700±30	9270-9120 cal. BC (86.5%) 8980-8930 cal. BC (8.9%)
Beta-617534	LTC43M21 OCA-WS-307		2.38-2.39m	2.38-2.39m	Organic sediment	alkali insoluble	-27.7	11180±30	11220-11130 cal. BC
Beta-617530	LTC43M21 <59>	1414	0.12-0.13m	0.72-0.73m	Organic sediment	alkali soluble	-29.9	2160±30	360-270 cal. BC (36.4%) 260-90 cal. BC (57%) 80-50 cal. BC (2%)
Beta-617531	LTC43M21 <59>	1414	0.12-0.13m	0.72-0.73m	Organic sediment	alkali insoluble	-32.0	2290±30	410-350 cal. BC (60.4%) 300-200 cal. BC (35%)
Beta-617525	LTC43M21 <58>	1412	0.08-0.09m	0.32-0.33m	Organic sediment	alkali soluble	-29.2	1100±30	Cal. AD 880-1020
Beta-617526	LTC43M21 <58>	1412	0.08-0.09m	0.32-0.33m	Organic sediment	alkali insoluble	-27.6	1200±30	Cal. AD 700-740 (5%) Cal. AD 770-900 cal. (88.3%) Cal. AD 920-950 (2.1%)
Beta-617523	LTC43M21 <10>	10706	0.32-0.33m	1.47-1.48m	Organic sediment	alkali soluble	-30.2	2800±30	1050-1030 cal. BC (1.6%) 1020-890 cal. BC (88.2%) 880-840 cal. BC (5.7%)
Beta-617524	LTC43M21 <10>	10706	0.32-0.33m	1.47-1.48m	Organic sediment	alkali insoluble	-29.7	3070±30	1420-1250 cal. BC (94.8%) 1240-1230 cal. BC (0.6%)
Beta-618695	LTC43M21 <10>	10702	0.11-0.12m	0.55-0.56m	Organic sediment	Alkali soluble	-28.8	1380±30	Cal. AD 600-680 (93.6%)

Lab. reference	Sample	Context	Depth from top of monolith/core	Depth BGL	Material	Fraction dated	$\delta^{13}\text{C}$ (‰)	Radiocarbon Age (BP)	Calibrated date BC/AD (at 95.4%)
									Cal AD 740-760 (1.8%)
Beta-617528	LTC43M21 <10>	10702	0.11-0.12m	0.55-0.56m	Organic sediment	Alkali insoluble	-27.9	2040±30	160 cal. BC- cal. AD 70
Beta-617521	LTC43M21 WS414A		2.63-2.64m	2.63-2.64m	Organic sediment	alkali soluble	-29.5	3450±30	1890-1680 cal. BC (93.9%) 1660-1640 cal. BC (1.5%)
Beta-617522	LTC43M21 WS414A		2.63-2.64m	2.63-2.64m	Organic sediment	alkali insoluble	-27.9	3700±30	2200-2160 cal. BC (9.6%) 2150-2010 cal. BC (82.4%) 2000-1970 cal. BC (3.4%)
Beta-617520	LTC43M21 WS414A		1.43-1.48m	1.43-1.48m	Seeds (<i>Carex</i>)		-25.4	2690±30	910-800 cal. BC
Beta-617519	LTC43M21 WS405A		2.56-2.61m	2.56-2.61mm	Seeds (<i>Chenopodium</i> , <i>Eleocharis</i> , <i>Carex</i>)		-28.2	3180±30	1510-1400 cal. BC
Beta-617518	LTC43M21 WS405A		1.4-1.45m	1.4-1.45m	Seeds (<i>Carex</i>)		-25.0	2730±30	930-810 ca. BC
Beta-617529	LTC43M21 <42>	10703	0.8-0.9m	0.8-0.9m	Seeds (<i>Carex</i> , <i>Chenopodium</i> , <i>Solanum nigrum</i> , <i>Ranunculus scleratus</i>)		-24.8	2430±30	750-680 cal. BC (18.2%) 670-630 cal. BC (7.8%) 590-400 cal. BC (69.5%)
Beta-617532	LTC43M21 WS503A		1.50-1.55m	1.5-1.55m	Seeds (Cyperaceae including <i>Carex</i>)		-29.0	2520±30	790-720 cal. BC (25.7%) 710-540 cal. BC (69.8%)
Beta-617517	LTC43M21 WS503A		3.08-3.13m	3.08-3.13m	Seeds (Cyperaceae, <i>Rubus</i> , <i>Eleocharis palustris</i> , <i>Ranunculus acris/repens/bulbosus</i>)		-27.9	2990±30	1380-1350 cal. BC (4.9%) 1310-1120 cal. BC (90.5%)

Lab. reference	Sample	Context	Depth from top of monolith/core	Depth BGL	Material	Fraction dated	$\delta^{13}\text{C}$ (‰)	Radiocarbon Age (BP)	Calibrated date BC/AD (at 95.4%)
Beta-613902	LTC43M21 <96>	606			Charcoal (Maloideae)		-25.7	2830±30	1110-900 cal. BC
Beta-603776	LTC43M21	1422			Wood (<i>Quercus</i>)		-27.3	2460±30	760-410 cal. BC

Table 17: Radiocarbon determinations

		From (cal AD)	To (cal AD)	%	From (cal AD)	To (cal AD)	%
Beta-617525	alkali soluble	896	992	68.3	887	1017	95.4
Beta-617526	alkali insoluble	782	881	68.3	706	945	95.4
R_Combine (1150±22 BP)		770	980	68.3	770	980	95.4

X-Test fails at 5% - X2-Test: df=1 T=5.555(5% 3.8)

Table 18: Results of paired χ^2 test on sediment from monolith 58 (1412) at 0.08-0.09m (end points of the combined calibrated date are rounded out by 10 years)

		From (cal BC)	To (cal BC)	%	From (cal BC)	To (cal BC)	%
Beta-617530	alkali soluble	350	122	68.3	356	57	95.4
Beta-617531	alkali insoluble	399	236	68.3	405	209	95.4
R_Combine (2226±22BP)		370	200	68.3	390	200	95.4

X-Test fails at 5% - X2-Test: df=1 T=9.388 (5% 3.8)

Table 19: Results of paired χ^2 tests on sediment sample from monolith 59 (1414) at 0.12-0.13m (end points of the combined calibrated date are rounded out by 10 years)

		From (cal BC)	To (cal BC)	%	From (cal BC)	To (cal BC)	%
Beta-617523	alkali soluble	996	913	68.3	1044	841	95.4
Beta-617524	alkali insoluble	1396	1286	68.3	1417	1236	95.4
R_Combine (2938±22BP)		1207	1115	68.3	1220	1051	95.4

X-Test fails at 5% - X2-Test: df=1 T=40.481(5% 3.8)

Table 20: Results of paired χ^2 tests on sediment sample from monolith <10> (10706) at 0.32-0.33mm (end points of the combined calibrated date are rounded out by 10 years)

		From (cal BC)	To (cal BC)	%	From (cal BC)	To (cal BC)	%
Beta-617521	alkali soluble	1873	1693	68.3	1881	1642	95.4
Beta-617522	alkali insoluble	2138	2036	68.3	2199	1980	95.4
R_Combine (3578 ±22BP)		1960	1890	68.3	2020	1820	95.4

X-Test fails at 5% - X2-Test: df=1 T=34.708(5% 3.8)

Table 21: Results of paired χ^2 tests on peat samples from WS414A at 2.63-2.64m (end points of the combined calibrated date are rounded out by 10 years)

		From (cal BC)	To (cal BC)	%	From (cal BC)	To (cal BC)	%
Beta-617533	alkali soluble	9247	9163	68.3	9261	8931	95.4
Beta-617534	alkali insoluble	11205	11140	68.3	11215	11131	95.4
R_Combine (10542±22BP)		10680	10540	68.3	10730	10530	95.4

X-Test fails at 5% - X2-Test: df=1 T=1199.912(5% 3.8)

Table 22: Results of paired χ^2 tests on humic sediment from OCA-WS-307 at 2.38-2.39m (end points of the combined calibrated date are rounded out by 10 years)

		From (cal BC/AD)	To (cal AD)	%	From (cal BC/AD)	To (cal AD)	%
Beta-618695	alkali soluble	Cal. AD 612	669	68.3	601	758	95.4
Beta-617526	alkali insoluble	91 cal. BC	16	68.3	151 cal. BC	62	95.4
R_Combine		Cal AD 256	377	68.3	Cal. AD 250	404	95.4

X-Test fails at 5% - X2-Test: df=1 T=241.321(5% 3.8)

Table 23: Results of paired χ^2 tests on organic sediment from <10> (10702) 0.11-0.12m (end points of the combined calibrated date are rounded out by 10 years)

C.6 Foraminiferal/Ostracod Assessment

By John E. Whitaker

Introduction

- C.6.1 Nine samples recovered from sediments within the Mar Dyke valley palaeochannel sequences and were submitted for the identification of foraminifera and/or ostracods or any other remains of environmental potential. The aim was to ascertain whether there is a brackish component and especially whether the Mar Dyke was ever tidal this far upstream.

Materials and Methods

- C.6.2 Details of the submitted samples are given in Table 24 below.

Depth (m)	Monolith/core	Context	Weight processed (g)
0.66-0.68	10	10702	62
0.97-0.98	11	10704	68
1.16-1.18	38	10705	55
1.38-1.40	38	10705	42
1.67-1.71	39	10707	62
1.87-1.89	405A	-	65
2.40-2.42	414A	-	90
2.53-2.55	405A	-	70
2.97-2.99	414A	-	102

Table 24: Details of the ostracod samples

- C.6.3 For the most part the sediments were quite organic. In each case they were reduced into small pieces, placed in ceramic bowls and dried in an oven. Boiling-hot water was then poured over them, with a little sodium carbonate added to help disaggregate any clay fraction and release the organic component. Each was left to soak overnight or for even longer. Washing was with hand-hot water through a 75 micron sieve which took some time to achieve a clean breakdown. The remaining residue was finally returned to the ceramic bowl for final drying in the oven. On completion of this stage the samples were stored in labelled plastic bags. For examination, each sample was placed in a nest of sieves (>500, >250, >150 microns, and base pan) and thoroughly shaken. A little of each grade was then sprinkled onto a picking tray and viewed under a binocular microscope. Notes were taken of the contained material, which are presented graphically in Table 25.

Results

- C.6.4 The results of the microfaunal assessment of the 9 samples from the Mar Dyke are shown in Table 25 below, where the samples are laid out in order of depth, but it must be remembered they are from a series of different monoliths and cores with the upper sequence covering the interval 0.66 – 1.71m depth (and contexts 10702, 10705 and 10707) and a lower part covering the interval 1.87 – 2.99m depth. An ecological synopsis of the interpretation is included.

Monolith/Core Number	10	11	38	38	39	405A	414A	406A	414A
Depth (m)	0.66-0.68	0.97-0.98	1.16-1.18	1.38-1.40	1.67-1.71	1.87-1.89	2.40-2.42	2.53-2.55	2.97-2.99
plant debris + seeds	x	x	x	x	x	x	x	x	x
insect remains		x	x		x	x			
cladocerans + ehippia	x		x	x	x	x		x	
Sediment	<i>brown</i>	<i>organic</i>				<i>organic</i>	<i>silt</i>	<i>organic</i>	<i>Sandy silt</i>
Ecology	<i>Vegetated freshwater slow-moving stream</i>					<i>Freshwater stream, sometime vegetated, variable energy</i>			

Contained material is recorded on a presence/absence (x) basis only

Table 25: Presence/absence of environmental remains by depth with ecological synopsis

- C.6.5 The sediments are mostly very organic with much plant debris (almost a peat in places), and containing seeds varying from large ones to many small seeds (e.g. 0.66-0.68m) which may be grass seed. In the lower part (at 2.40-2.42m and 2.97-2.99m depth) especially in the lowermost sample this is accompanied by silt and sandy-silt, indicative of a period of greater energy in the stream/river.
- C.6.6 None of the samples contain anything of a calcareous nature but almost all contain remains of cladoceran (water-flea) and their ehippia (egg-cases which are organic-walled). The cladocera clearly signifies a freshwater environment. There are no readily visible ostracods or foraminifera. A careful check was made of the very fine fraction of all the residues in case minute brackish foraminifera were present, as these might be expected in very low salinities at the head of a transgression, but none was seen. It is concluded that the Mar Dyke throughout the existence of this time frame was freshwater.

C.7 Diatom Assessment

By Dr Tom Hill

Introduction

- C.7.1 A total of thirteen samples were submitted for diatom assessment of sediments sampled within the Mar Dyke valley palaeochannel sequences. The samples all derive from ground investigations associated with Trench 4, either monolith samples (<10>, <11>, <38>, <39>; n. 7) or samples from borehole window sampling (WS405A, WS414A, WS307; n. 6).
- C.7.2 Visual inspection of the samples revealed that these comprised a mixture of silts and clays with varying organic content. Full stratigraphic information regarding the sequence is presented in Appendices A and C.9, and hence only brief descriptions will be provided where relevant when attempting to contextualise the results. The samples submitted for evaluation are listed below in Table 26.

Transect	Section	Monolith/Core	depth (mbgl)
Geoarchaeological Transect 4	10700	<10>	0.56-0.57
			0.66-0.67
			0.77-0.78
		<11>	0.97-0.98
		<38>	1.16-1.17
			1.38-1.39
	<39>	1.67-1.68	
	Geoarchaeological Transect 3	WS405A	1.87-1.88
			2.58-2.59
		WS414A	2.40-2.41
2.97-2.98			
WS307	1.76-1.76		
	2.36-2.37		

Table 26: Summary of samples for diatom assessment

- C.7.3 Radiocarbon dating revealed that samples from WS307 dated to the late glacial - early Holocene. Samples from WS414A likely date to the early-middle Bronze age, whilst samples from WS405A date to between the mid-late Bronze Age. Finally, the monolith sequence that includes <39>, <38>, <11> and <10> (oldest to youngest), returned dates to indicate these sediments span the mid-late Bronze Age to the mid-late Iron Age.

Methodology

- C.7.4 Diatom preparations first require 0.5g of sediment to be subsampled from each bulk sample. Due to the high silt and clay content of most samples, these samples were first treated with sodium hexametaphosphate and left overnight, to assist in minerogenic deflocculation. Samples were then treated with hydrogen peroxide (30% solution) to remove any organic material that may hinder visibility during subsequent microscopy assessment. Samples were finally sieved using a 10µm mesh to remove fine minerogenic sediments.

C.7.5 A minimum of 100 diatoms were to be identified for each sample depth. If diatoms were found to be present in low numbers (or indeed absent), a minimum of 10 slide traverses would be undertaken in an attempt to maximise the palaeo-environmental interpretation from each sample depth. When present, diatom species would be identified with reference to van der Werff and Huls (1958-74), Hendy (1964) and Krammer and Lange-Bertalot (1986-1991). Ecological classifications for the observed taxa were then achieved with reference to Vos and deWolf (1988; 1993), Van Dam *et al.*, (1994), Denys (1991-92; 1994) and Mann *et al.* (2007). Other potential microscopic environmental indicators encountered in the slides were also noted and commented upon, if relevant.

Results

C.7.6 Of the 13 samples under diatom assessment, full counts (>100 TDV) were only achieved for 5 samples. Of the remaining eight samples, two yielded no diatoms, whilst six samples contained assemblages of less than 100 diatoms. A summary of diatoms encountered during the assessment is provided in Table 27, with a brief summary relating to each sample/depth provided below.

C.7.7 **WS307:2.36-2.37, 1.75-1.76 bgl.** No diatoms were encountered in either sample from WS307. Fragments of microcharcoal were common in both samples.

C.7.8 **WS414A: 2.97-2.98m, 2.40-2.41m bgl.** A single frustule of the diatom *Eunotia monodon* was encountered in the lower sample (2.97-2.98m bgl) from WS414A. In contrast, the upper sample 2.40-2.41m bgl contained diatoms in abundance and diversity. The assemblage was wholly dominated by benthic species, with no planktonic diatoms encountered. Of those present, species of *Eunotia*, *Cocconeis*, *Gyrosigma* and *Pinnularia* were the most common. The most abundant taxa were *Eunotia monodon*, *Cocconeis placentula* and *Gyrosigma cf. acuminatum*. It was however noted that some frustules showed signs of dissolution and/or fragmentation, particularly the larger diatoms including *Gyrosigma sp* and *Pinnularia sp*. This often made identification to species level difficult. Chrysophyte cysts were also present in relative abundance within the upper sample.

C.7.9 **WS405A: 2.58-2.59m, 1.87-1.88m bgl.** Diatoms were encountered in abundance and diversity in both samples from WS405A. The assemblages encountered are very similar to one another, in addition to being similar to that present in WS414A 2.40-2.41m bgl. The most abundant diatoms were species of *Eunotia*, *Cocconeis*, *Gyrosigma* and *Pinnularia*. The most common taxa were *Cocconeis placentula*, *Eunotia monodon*, *Gyrosigma cf. acuminatum* and *Pinnularia cf. viridis*. Additional species of note include *Eunotia bidens* and *Hantzschia amphioxys*. The larger diatoms once again often displayed evidence of dissolution and fragmentation, whilst chrysophyte cysts were also encountered in abundance. There are some species present in the upper sample 1.87-1.88m bgl that are absent from the underlying sample, including *Craticula sp.*, *Tryblionella gracilis* and *Stauroneis gracilis*.

C.7.10 **<39> 1.67-1.68m bgl.** Diatoms were present within this sample, but only in moderate abundance and diversity. As such a full assessment count could not be achieved. In addition, the majority of species encountered displayed evidence of frustule dissolution and/or fragmentation. This often resulted in incomplete frustules being preserved and hence it was difficult to identify diatoms to species level. The most common diatoms were *Gyrosigma sp* and *Pinnularia sp*. Other diatoms encountered

included *Craticula cuspidata*, *Tryblionella gracilis* and *Cocconeis placentula*. Chrysophyte cysts were also encountered in abundance.

- C.7.11 **<38> 1.38-1.39, 1.16-1.17m bgl.** Diatoms were encountered in abundance and diversity in both samples from <38> enabling full assessment counts. There was slightly greater diversity within the assemblage from the lower level 1.38-1.39m bgl, but the two assemblages were broadly similar, and very similar again to those encountered in WS405A 2.58-2.59m bgl and WS4041A 2.40-2.41m bgl. Once again species of *Cocconeis*, *Eunotia*, *Gyrosigma* and *Pinnularia* are the most abundant, with *Cocconeis placentula*, *Eunotia monodon*, *Gyrosigma cf. acuminatum* and *Pinnularia cf. viridis*. Additional taxa of note include *Gomphonema ovilaceum*, *Stauroneis gracilis* and *Pinnularia cf. microstauron*. Chrysophyte cysts were common in both samples, whilst testate amoebae were also occasionally encountered in the upper sample 1.16-1.17m bgl. The testate amoebae encountered were tentatively identified as *Cyclopyxis arcelloides* type.
- C.7.12 **<11> 0.97-0.98m bgl.** Diatoms were present within this sample, but only in low abundance and diversity, and a full assessment count could not be achieved. In addition, the majority of species encountered displayed evidence of frustule dissolution and/or fragmentation. This often resulted in incomplete frustules being preserved and hence it was difficult to identify diatoms to species level. The most common diatoms were fragments of *Pinnularia* sp. Other diatoms encountered included *Eunotia monodon*, and *Anomoeoneis sphaerophora*. Chrysophyte cysts were also encountered in high numbers.
- C.7.13 **<10> 0.77-0.79m, 0.66-0.67m, 0.56-0.57m bgl.** Diatoms were encountered in low numbers in the lower sample, and only in moderate abundance in the upper two samples and so full assessment counts could not be achieved. Dissolution and frustule fragmentation was also common, making reliable identifications difficult. The diatoms that were present, however, were similar in each of the three samples. The most common were fragments of *Pinnularia* sp., and fragments of *Cymbella* sp. Chrysophyte cysts are encountered in abundance in all three samples, whilst the testate amoebae, again tentatively identified as *Cyclopyxis arcelloides* type, is encountered in abundance in the lower two samples (0.77-0.78m, 0.66-0.67m bgl). Microcharcoal is also abundant in the uppermost sample (0.56-0.57m bgl).

Discussion

- C.7.14 Diatoms were encountered in relative abundance and diversity in some of the samples submitted for assessment, but other samples yielded limited results. However, it was noted that when present in sufficient abundance for assessment counts to be achieved, broadly similar diatom assemblages were encountered. As such it seems apparent that similar depositional environments likely prevailed during the deposition of sediment samples WS414 2.40-2.41m, WS405A 2.58-2.59m, WS405A 1.87-1.88m bgl and <38> 1.38-1.39m and <38> 1.16-1.17m bgl. The diatom assemblages in which preservation was found to be good appear to span the early to middle Bronze Age.
- C.7.15 The diatoms encountered within these samples were typified by the benthic species *Cocconeis placentula*, *Eunotia monodon*, *Gyrosigma cf. acuminatum* and *Pinnularia cf. viridis*. The identification of *Gyrosigma cf. acuminatum* and *Pinnularia cf. viridis* are tentative due to these frustules often displaying fragmentation or dissolution.

However, when identifications to species level were possible, these diatoms (and indeed the majority encountered within each assemblage) are either classified as epipelagic (thrive on muddy substrates), epiphytic (thrive on living or decaying organic matter), or are aerophilous (prefer periods of submergence and emergence from water). It is interesting to note that no planktonic diatoms were encountered in any samples, irrespective of the state of preservation. This would suggest that all depositional contexts were probably very shallow. This is supported by the presence of aerophilous taxa due to their need to be proximal to the water margins.

Transect	Monolith/core	Depth (mbgl)	Transect 4										Transect 3		
			<10>			<11>	<38>		<39>	WS405A		WS414A		WS307	
			0.56-0.57	0.66-0.67	0.77-0.78	0.97-0.98	1.16-1.17	1.38-1.39	1.67-1.68	1.87-1.88	2.58-2.59	2.40-2.41	2.97-2.98	1.75-1.76	2.36-2.37
	<i>Amphora ovalis</i>								2	2					
	<i>Anomoeoneis sphaerophora</i>		1		2	1	1	2	1	2					
	<i>Caloneis sillicula</i>						1								
	<i>Cocconeis placentula</i>					7	2	3	20	25	19				
	<i>Cocconeis pediculus</i>									2	1				
	<i>Craticula ambigua</i>					1			3						
	<i>Craticula cuspidata</i>					2	1		5		2				
	<i>Cymbella sp.</i>	11	6	1			1			1					
	<i>Cymatopleura solea</i>								1						
	<i>Epithemia sp.</i>						2		2	2					
	<i>Eunotia sp.</i>					2	2		2	3	2				
	<i>Eunotia bidens</i>						1		1	4					
	<i>Eunotia gracilis</i>						1								
	<i>Eunotia monodon</i>				2	17	38		14	22	37	1			
	<i>Eunotia pectinalis</i>					1	1		1						
	<i>Gomphonema acuminatum</i>								1	1	2				
	<i>Gomphonema ovilaceum</i>							5	1	1	1				
	<i>Gyrosigma sp.</i>				2										
	<i>Gyrosigma cf. acuminatum</i>					43	19		30	30	16				
	<i>Gyrosigma distortum</i>					2									
	<i>Gyrosigma litorale</i>														
	<i>Gyrosigma wansbeski</i>														
	<i>Gyrosigma scalproides</i>														
	<i>Hantzschia amphioxys</i>						3		3	5	3				
	<i>Navicula sp.</i>					1									
	<i>Navicula cuspidata</i>														
	<i>Navicula cincta</i>														
	<i>Navicula distans</i>														
	<i>Navicula pusilla</i>								1		1				
	<i>Navicula radiosa</i>					1	2		4	2	4				
	<i>Neidium amphirhynchus</i>							1		1					
	<i>Neidium iridis</i>					8	2		3						
	<i>Nitzschia punctata</i>														

Transect	Monolith/core	Depth (mbgl)	Transect 4										Transect 3		
			<10>			<11>	<38>		<39>	WS405A		WS414A		WS307	
			0.56-0.57	0.66-0.67	0.77-0.78	0.97-0.98	1.16-1.17	1.38-1.39	1.67-1.68	1.87-1.88	2.58-2.59	2.40-2.41	2.97-2.98	1.75-1.76	2.36-2.37
	<i>Nitzschia sigma</i>							1							
	<i>Nitzschia scalaris</i>														
	<i>Petroneis marina</i>														
	<i>Pinnularia sp.</i>	34	31	11	8			12	3		2				
	<i>Pinnularia borealis</i>						1								
	<i>Pinnularia lata</i>									1					
	<i>Pinnularia cf. microstauron</i>					3	4		3		2				
	<i>Pinnularia nobilis</i>		1			3	1								
	<i>Pinnularia cf. viridis</i>		1			20	14	1	8	8	9				
	<i>Placoneis sp.</i>						1								
	<i>Rhabdonema arcuatum</i>														
	<i>Rhopalodia sp.</i>														
	<i>Scolioleura tumida</i>														
	<i>Staureoneis gracilis</i>					3	5	1	5		2				
	<i>Staureoneis phoenicenteron</i>														
	<i>Suirella sp.</i>														
	<i>Trachyneis aspera</i>														
	<i>Tryblionella gracilis</i>					2	3	4	18		2				
	<i>Ulnaria ulna</i>		1			1		1	1	1					
	Charcoal	xxx										xx	xx		
	Testate amoebae		xx	xxx		x									
	Chrysophyte cysts	xxx	xxx	xxx	xxx	xx	xx	xx	xx	xx	xx				
	Abundance	mod	mod	low	low	high	high	mod	high	high	high	low	n/a		
	Diversity	low	low	low	low	high	high	mod	high	high	high	low	n/a		
	Suitable for further analysis?	n	n	n	n	y	y	n	y	y	y	n	n		

Table 27: Summary of diatoms encountered within assessed samples

- C.7.16 In terms of salinity preference, it is likely that all samples in which full assessment counts were achieved, developed in freshwater contexts. Whilst there are some diatom genera present that can be common in depositional environments with saline influence such as the supratidal and intertidal zones (e.g. *Cocconeis* sp., *Gyrosigma* sp, *Cymbella* sp., *Tryblionella* sp.), the same diatoms can be also be typical in freshwater settings. When combined with the relative abundance of diatoms such as the often halophobous (purely freshwater) genera *Eunotia* sp, a freshwater setting seems more likely. Furthermore, there is a total absence of any obvious diatoms that thrive in more saline contexts, as well as the absence of any marine planktonic taxa (that are often present if a depositional setting is tidally influenced), reinforcing this interpretation. Finally, as noted in Table 27, the majority of samples contained chrysophyte cysts, which are predominantly freshwater and are found in specific habitats such as lakes, wet meadows, ephemeral ponds, and *Sphagnum* bogs. The testate amoebae *Cyclopyxis arcelloides* is less common and only encountered in three of the samples, but is most often linked to freshwater contexts and sphagnum mosses. The evidence from chrysophyte cysts and testate amoebae offered above is, however, tentative and would require confirmation by specialists in their identification and interpretation.
- C.7.17 Less can be said of those samples in which diatoms were encountered in lower numbers. The samples from WS307 yielded no palaeo-environmental information. Elsewhere, as a general rule, when present, albeit in lower numbers, the diatoms present appeared broadly similar to those encountered in samples in which full assessment counts were achieved (*Gyrosigma* sp, *Pinnularia* sp etc). However whilst a tentative interpretation could be that similar depositional environments therefore could have prevailed in those samples in which diatoms were present but in low numbers, the prevalence of diatom dissolution and fragmentation meant that some diatom frustules may have not survived preservation and identifications were tentative. As such, alternative palaeo-environmental evidence would be needed to assist in understanding the depositional environments of those samples in which diatom evidence was limited.

Recommendations for further analysis

- C.7.18 When encountered in sufficient abundance, the diatom assemblages present within the samples suggest deposition within a shallow freshwater setting during the early- to mid-Bronze Age. Full analysis would confirm this, by confidently identifying all diatoms to species level where possible, in addition to undertake higher diatom counts to elucidate whether there is any subtle marine influence. But it is noted that dissolution appeared to be an issue in the majority of samples, which has the potential to restrict identifications. Whilst samples were on the whole similar when compared to one another, which in turn suggests broadly similar depositional conditions, differences between the assemblages would require further analysis to understand whether there are changing conditions with height through profiles, such as those in <38> and WS405A. Full analysis would understand the variety of diatoms and associated environmental preferences (epiphytes vs epipelon vs aerophiles etc) in order obtain a better understanding of the depositional contexts.

C.8 Pollen Assessment

By Mairead Rutherford

Introduction

- C.8.1 Fourteen sub-samples were selected and submitted for pollen assessment following initial assessment of the geoarchaeological data, monoliths and cores.

Methodology

- C.8.2 The samples for pollen assessment were prepared by Neil Jones at PalaeoStrat Ltd., using a standard chemical procedure (method B of Berglund and Ralska-Jasiewiczowa 1986), using HCl, NaOH, sieving, HF, and Erdtman's acetolysis, to remove carbonates, humic acids, particles > 170 microns, silicates and cellulose, respectively. The samples were then stained with safranin, dehydrated in tertiary butyl alcohol, and the residues mounted in 2000cs silicone oil. Slides were examined at a magnification of 400x by ten equally-spaced traverses across at least two slides to reduce the possible effects of differential dispersal on the slides (Brooks and Thomas 1967) or until at least 100 pollen grains were counted, where the total land pollen (TLP) count is comprised of trees, shrubs and herbs. Fern spores and pollen of aquatic plants are counted separately. Pollen identification was made following the keys of Moore *et al* (1991), Faegri and Iversen (1989), and a small modern reference collection. Identification of non-pollen palynomorphs (NPP) follows van Geel (1978). Plant nomenclature follows Stace (2010). The preservation of the pollen was noted, and an assessment was made of the potential for further analysis.

Details of the samples and preservation of pollen

- C.8.3 A list of the sub-samples submitted, together with supplied context, lithology and age data, are summarised below on Table 28. The 7 sub-samples from monoliths 10, 38 and 39, comprise one stratigraphic composite section. A correlation diagram for cores WS307, WS405A and WS414A, from which the remaining 7 sub-samples are taken, is available in the main report (Fig. 21).

Monolith/ Core	Sample depth (m)	Context	Lithology	Age	Pollen Good/Poor
10	0.12-0.13	10702	Peat	middle -late Iron Age or Saxon	Good
10	0.20-0.21	10702	Alluvium		Good
10	0.32-0.33	10703	Peat	early Iron Age	Good
10	0.45-0.46	10703	Organic silt		Good
38	0-0.01	10705	Organic silt		Good
38	0.23-0.24	10706	Peat	middle to late Bronze Age	Good
39	0.12-0.13	10707	Alluvium		Good
WS307	1.75-1.76		Head (?)		Poor
	2.38-2.39		Peat	Late Glacial-early Holocene	Poor
WS405A	1.87-1.88		Alluvium	Below late Bronze Age peat	Good

Monolith/ Core	Sample depth (m)	Context	Lithology	Age	Pollen Good/Poor
	2.57-2.58		Peat	Middle Bronze Age	Good
WS414A	1.79-1.80		Organic silt	Below late Bronze Age peat	Good
	2.62-2.63		Organic silt	Early Bronze Age	Good
	2.97-2.98		Alluvium	Below early Bronze Age organics	Poor

Table 28: Details of pollen subsampling

Results

- C.8.4 The pollen assemblages derived from the lithostratigraphic sequence outlined in Table 28 (above) are described and then interpreted below. Detailed pollen counts can be found in Table 29 at the end of the assessment report.

Transect 4, Trench section 10700: Monoliths 10, 38 and 39 (seven sub-samples)

- C.8.5 **Monolith sample 39 (10707) at 1.67-1.68m bgl.** The oldest assemblages, preserved in an alluvial deposit, contain pollen dominated by grasses (Poaceae), with other herbs including sedges (Cyperaceae), daisy family (Asteraceae, inclusive of plants such as slender thistle (*Carduus tenuiflorus*), nipplewort (*Lapsana communis*) and perennial sow-thistle (*Sonchus arvensis*)), dandelion-type (*Taraxacum*-type), ribwort plantain (*Plantago lanceolata*), mugworts (*Artemisia*), pink family (Caryophyllaceae, including plants such as stitchworts/chickweeds (*Stellaria*) and mouse-ears (*Cerastium*), buttercup family (Ranunculaceae) and goosefoot family (Amaranthaceae, formerly Chenopodiaceae, a large group including plants such as fat-hen (*Chenopodium album*), many-seeded goosefoot (*C. polyspermum*) and good-king-henry (*C. bonus-henricus*)). Cereal-type pollen represents 10% of the assessed assemblage, with grains probably attributable to barley (*Hordeum*-type) as well as wheat/oats (*Triticum/Avena*).
- C.8.6 Tree and shrub pollen accounts for approximately 24% of the total land pollen count (i.e. trees, shrubs and herbs); and the pollen includes commonly occurring hazel-type (*Corylus avellana*-type) with fewer occurrences of alder (*Alnus*) and oak (*Quercus*), and presence of birch (*Betula*), ash (*Fraxinus*), elm (*Ulmus*), lime (*Tilia*) and beech (*Fagus*).
- C.8.7 Fern spores of common polypody (*Polypodium vulgare*) are present in low frequency. In contrast, pollen of aquatic plants occurs in relatively significant quantities, the most common being lesser bulrush (*Typha angustifolia*), as well as rare occurrences of pollen of water milfoils (*Myriophyllum*), including whorled water milfoil (*M. verticillatum*) as well as spiked water-milfoil (*M. spicatum*). The water plantain family (Alismataceae) is represented by pollen of arrowheads (*Sagittaria*-type). Green algae are also present in the assemblage, and include both smooth and reticulate forms of *Spirogyra* (HdV-131) as well as the freshwater algal type *Botryococcus* (HdV-766). No microcharcoal is recorded.
- C.8.8 **Monolith sample 38 (10706) at 1.38-1.39m bgl.** The assessed assemblage from the late – middle Bronze Age peat contain abundant grass and sedge pollen, as well as

a similar range of herbs to those described from the underlying alluvium (see above); however, lower frequencies of cereal-type pollen are present. Tree and shrub pollen represents approximately 28% of the total pollen count, with hazel-type contributing approximately 16% and apparent absence of lime pollen. Fern spores are commonly recorded, in particular, monolete ferns (Pteropsida) as well as occurrences of common polypody and bracken (*Pteridium aquilinum*). Pollen of aquatic plants comprises roughly equal quantities of bulrush (*T. latifolia*) and lesser bulrush and a few grains of arrowheads. Green algae are represented by rare occurrence of *Mougeotia* (HdV-313). Fungal spores are also poorly represented, with only a single record for *Sordaria* (HdV-55A/B) recorded. Microcharcoal is present in very low quantity.

- C.8.9 Monolith sample 38 (10705) at 1.16-1.17m bgl.** The organic silt overlying the late-middle Bronze Age peat contains similar assemblages to those already outlined (above). Pollen of grasses and sedges again dominate the assemblage; however, a greater diversity of herb pollen is recorded. In addition to the taxa already outlined, docks/sorrels (*Rumex*-type), thistles (*Cirsium*-type), pea family (Fabaceae, a large group including plants such as clovers (*Trifolium*-type) and vetches (*Vicia*-type), devil's bit scabious (*Succisa pratensis*) and pollen of the willow-herb family (*Epilobium*-type), are recorded. Rare cereal-type pollen is present. Tree and shrub pollen represents approximately 35% of the total pollen count, and (additionally) includes occurrences of ivy (*Hedera*) and elder (*Sambucus*). Pollen of lime is very rare. Fern spores and pollen of aquatic plants are present in relatively robust numbers, with the most common ferns represented by monolete types and the most common aquatic plants indicated from abundant occurrence of pollen of lesser bulrush. A single fungal spore, *Podospora* (HdV-368) is recorded and several types of green algae are also present (including *Spirogyra* HdV-131, *Mougeotia* (HdV-313) as well as oospores of Oedogoniaceae (HdV-166). Little microcharcoal is present.
- C.8.10 Monolith sample 10 (10703) at 0.94-0.95m bgl.** Pollen is well preserved in this organic silt deposit and contains an assemblage very similar to those previously outlined (above). Tree and shrub pollen contribute approximately 30% of the total pollen count, with assessment suggesting oak may be the most commonly occurring. Sedge pollen appears to exceed counts for grasses; cereal-type pollen is present in low numbers. Fern spores and pollen of aquatic plants occur consistently but in relatively low amounts. Green algae are represented by *Mougeotia*-type (HdV-313) and *Spirogyra* (HdV-131). Microcharcoal values are very low.
- C.8.11 Monolith sample 10 (10703) at 0.77-0.78m bgl:** Early Iron Age peat. This sample is characterised by an apparent reduction in tree pollen (representing approximately 12% of the total land pollen count) and an abundance of pollen of grasses/sedges (approximately 73% of TLP). Pollen of lime is notably absent from the assemblage. A single cereal-type grain is present. A reduction in the quantity of pollen from aquatic plants is also recorded. Monolete fern spores are present in robust numbers. There is little microcharcoal recorded.
- C.8.12 Monolith sample 10 (10702) at 0.66-0.67m bgl.** Alluvium overlying early Iron Age peat: A possible slight increase in tree pollen is noted, with grains of heather (*Calluna*) and pine (*Pinus*) present, but with apparent absence of lime. The assemblage is dominated by grass pollen (57% TLP) with cereal-types also recorded. A relatively diverse herb assemblage includes occurrences of common knapweed (*Centaurea*

nigra), thistles, mints (*Mentha*-type), mugworts, pollen of the pink family and sedges. Rare fern spores are recorded and pollen of aquatic plants is also low. Rare green or freshwater algae occur. There is very little microcharcoal.

- C.8.13 **Monolith sample 10 (10702) at 0.56-0.57m bgl:** peat of middle-late Iron Age or Saxon date. The topmost sample in this section comprises abundant pollen and is characterised by hazel-type, which dominates the pollen counts (45%) with tree and shrub pollen accounting for approximately 63% of the total count. Herb pollen appears relatively poorly diverse, dominated by grasses, with occurrences of pollen of the daisy family, carrot family (Apiaceae, a large group including plants such as fool's-water-cress (*Apium nodiflorum*), sweet cicely (*Myrrhis odorata*) and marsh pennywort (*Hydrocotyle vulgaris*)), thistles and ribwort plantain. No cereal-type pollen is recorded. Abundant pollen of aquatic plants, of bulrush in particular, is recorded. Of significance also is a large count of *Sphagnum* moss spores. Fern spores include counts of common polypody and more significant counts of monolete ferns. Rare green algal types are present. Microcharcoal is present in low quantities.

Transect 3: Core WS307

- C.8.14 The sample at 2.38-2.39m, which could date to the late Glacial or the early Holocene, yielded little pollen, some grasses and monolete fern spores are present. The green algal type, *Mougeotia* (HdV-313) is recorded. Microfossil type 128 is also present.
- C.8.15 The sample at 1.75-1.76m also recorded very poor recovery of pollen, with isolated occurrences of lime, grasses, sedges and a cereal-type recorded. Monolete fern spores are also present.

Transect 4: Core WS405A

- C.8.16 The sample at 2.58m is from a peat, dated to the middle Bronze Age. The pollen is characterised by a tree and shrub assemblage, largely dominated by pollen of lime, followed by hazel-type, oak, alder and ivy. Herbs are dominated by grasses, with higher frequencies of ribwort plantain, buttercup-type and dandelion-type and less commonly occurring pollen of the pink and goosefoot families, and sedges. Fern spores are present, including common polypody, bracken and monolete ferns. Pollen of the aquatic plant, bulrush, is commonly recorded. Rare NPP include occurrences of fungal spores of *Podospora* (HdV-368) and *Sordaria* (HdV-55A/B) and the green algal type, *Spirogyra* (HdV-131). Microcharcoal is very rare.
- C.8.17 The sample at 1.88m is from alluvium, above the dated middle Bronze Age peat and below a peat deposit dated to the late Bronze. The tree and shrub pollen assemblage which is dominated by hazel-type, followed by oak, then alder and occurrences only of lime and ash. Grass pollen dominates the herb assemblage, with cereal-types accounting for more than 10% of the total pollen count. Pollen from aquatic plants includes dominance of grains of bulrushes, with lesser bulrush and arrowheads also recorded. Green algal types include *Spirogyra* (HdV-131) and *Mougeotia* (HdV-313). There is a single record for moss spores of *Sphagnum*. Microcharcoal is rarely present.

Transect 4: Core WS414A

- C.8.18 Three sub-samples were taken from this core. The sample at 2.97-2.98m is from an alluvial deposit beneath dated early Bronze Age organics, the sub-sample at 2.62-

2.63m is from the lower part of an organic silt deposit and the sub-sample at 1.79-1.80m is from the upper part of an organic silt deposit. The peat overlying this organic silt has been dated to the middle Bronze Age.

- C.8.19 The deepest sub-sample, at 2.97-2.98m, is pollen poor, with a count of only 32 total land pollen grains; however, abundant fern spores, in particular of common polypody, are recorded. The most common tree pollen type recorded is pine (*Pinus*), followed by hazel-type, with lime, oak and alder also present. Rare pollen of herbs includes occurrences of daisy type, sedges, grasses, buttercup- and goosefoot families. NPP include occurrence of green algae and scalariform perforation plates (HdV-114).
- C.8.20 At 2.62-2.63m, a rich pollen assemblage is dominated by pollen of lime, with hazel-type and alder also present. A relatively diverse herb assemblage includes higher counts of grasses and sedges, with occurrences of ribwort plantain, cereal-type, docks/sorrels, dandelion-, goosefoot- and daisy families as well as pollen of the pea family (Fabaceae), including clovers (*Trifolium*-type). Fern spores are present in abundance, with high frequency of both common polypody and monoete ferns. Pollen from aquatic plants is rarely recorded and includes occurrences of bulrush and duckweed (*Lemna*-type). NPP are overwhelmingly dominated by abundance of fungal spores of *Sporomiella* (HdV-113); commonly occurring scalariform perforation plates are also present (HdV-114). Microcharcoal values are low.
- C.8.21 At 1.79-1.80m, a rich pollen assemblage is dominated by herbs, in particular, grasses, which account for approximately 58% of TLP. A relatively diverse range of herbs includes occurrences of ribwort plantain, docks/sorrels, cereal-types, pink family, thistles (*Cirsium*-type), mints (*Mentha*-type) as well as more commonly recorded pollen of the daisy- and dandelion families. Tree and shrub pollen accounts for approximately 19% of TLP, consisting mostly of oak and hazel-type but with alder, birch, lime, willow, birch and beech (*Fagus*) also recorded. Fern spores are present; pollen from aquatic plants is dominated by bulrushes, with occurrences of lesser bulrush, arrowheads and white water-lilies (*Nymphaea alba*). NPP are represented by green algal types, in particular *Spirogyra* (HdV-130). Rare fungal spores include occurrences of *Podospora* (HdV-368) and *Sordaria* (HdV-55A/B). Microcharcoal is rarely recorded.

Pollen interpretation

- C.8.22 No interpretation is possible for either of the sub-samples from core WS307, as neither produced sufficient pollen.
- C.8.23 In contrast, abundant pollen was present in most of the deposits from dated early Bronze Age peat through to and including peat dated from the middle to the late Iron Age. The stratigraphy reflects a series of peats intercalated with organic silts and alluvial deposits.
- C.8.24 The stratigraphically oldest deposit that produced sufficient pollen to allow palynological interpretation is from core WS414A, from an alluvial deposit underlying dated early Bronze Age organic silts. Although some pollen was preserved in this deposit, the abundance of fern spores together with commonly occurring pine pollen, may suggest preservation of more robust pollen types, which may have survived transport whilst other, more delicate pollen types did not preserve. The presence of green and freshwater algae provide evidence of shallow water environments.

- C.8.25 The overlying sub-sample, from an early Bronze Age organic silt deposit, contains abundant tree pollen, in particular of lime, with some hazel-type and some alder, reflecting, at assessment, an assemblage dominated by approximately 67% woodland. Openness within or adjacent to the woodland is suggested from a variety of pollen of herbs such as grasses, ribwort plantain, docks/sorrels, pollen of the goosefoot, pink, daisy and dandelion families, which may occupy disturbed ground or waste areas. Fern spores are particularly abundant and may have been epiphytic on woodland trees or growing at the edges of the woodland. Another striking aspect to the assemblage is the abundance of fungal spores of *Sporomiella* (HdV-113), a known coprophilic fungal spore, suggesting the presence of grazing herbivores.
- C.8.26 A sub-sample from a peat of middle Bronze Age, from core WS405A, contains pollen that may be interpreted to suggest expansion of open, grassy areas and decreasing woodlands. Although the arboreal assemblages are still dominated by lime pollen (followed by hazel-type and oak, with some alder), the overall woodland component of the total pollen count is approximately 43%, an apparent decrease of more than 20% in woodland coverage since the early Bronze Age assemblages (above), suggesting potential woodland clearance activity. An expansion of meadow areas may have provided environments for pastoral activity, supported by relatively commonly occurring ribwort plantain.
- C.8.27 Alluvium deposits and peats (the latter dated to the middle – late Bronze Age in sample <38>) contain similar pollen assemblages to each other. Three sub-samples are available from monolith samples <39> and <38>. Similar pollen assemblages from organic silts are also available from core WS414A (at 1.79-1.80m) and from core WS405A (at 1.87-1.88m). The pollen assessed from all of these sub-samples may be interpreted to suggest reducing woodland cover and expansion of open areas. The sub-samples from core WS405A and the sub-sample from monolith sample <39>, are perhaps, particularly significant, as several cereal-type grains (largely of wheat/oats and some barley) are recorded (accounting for approximately 10-13% of the total land pollen counted from each sub-sample, respectively). The distinction between wild and cultivated grass pollen is difficult as the dimensions of wild grasses that grow in wet areas, such as sweet-grasses (*Glyceria*-type), overlap with those of cultivated grains (Andersen 1979). If the pollen grains represent cultivated cereals, then the data suggest that arable farming may have been practiced locally or that cereal grains were derived (possibly fluvially) from arable fields upstream or brought on-site by people for local use or for animals (e.g. in straw or hay). Pollen from aquatic plants along with green algal types support the presence of fresh water in the environment, with oospores of Oedogoniaceae (HdV-166) indicative of quiet bodies of shallow, perhaps stagnant open water (van Geel 1978).
- C.8.28 Four sub-samples, all from monolith sample <10>, provide a snapshot of palaeoenvironments largely through an Iron Age sequence. The deepest sub-sample is from organic silts overlain by a peat, which is dated to the early Iron Age. This is in turn overlain by another alluvial package over which peat of middle – late Iron Age is deposited. Pollen from the deepest sub-sample, at 0.45-0.46m, may be interpreted to suggest a dominantly open, possible sedge-fen local environment, with trees and shrubs accounting for approximately 30% of the total pollen count. Oak and hazel-type are the most commonly recorded with alder, birch, elm and beech suggesting derivation from possible regional woodlands. Within the early Iron Age peat, a pollen sub-sample (0.32-0.33m) suggests only 12% arboreal cover, with further

development of sedge-fen communities and open grassy areas. The overlying alluvial deposits contains slightly higher proportions of tree and shrub pollen and a reduction in sedge fen communities. Grasses are the dominant herb type recorded and support a diverse herb community including plants associated with disturbed ground (for example, mugworts, thistles, ribwort plantain, docks/sorrels and common knapweed). Probable cereal-type pollen is recorded, including wheat/oats and possibly barley, and could have been derived from nearby arable land or brought on site by people, for example, in straw or hay for animal food or bedding. Grassy meadows would have provide suitable areas of land for pastoral farming.

- C.8.29 The overlying peat (context 10702), which could date either from the middle-late Iron Age or as late as the Saxon period, as the radiocarbon dates were inconsistent, contains quite a different pollen assemblage, in that shrub pollen, in particular hazel-type, contributes approximately 45% of the total pollen count (TLP). Pollen from other trees/shrubs records alder and oak, with occurrences only of elm, birch, willow and heather. These data may suggest re-growth of hazel-type scrub and may be indicative that some areas of land, perhaps previously used for pasture and/or arable activity, had been abandoned. Pollen of herbs is dominated by grasses, and together with daisies, thistles and ribwort plantain, may be interpreted to suggest that some meadow land still existed. The quantity of pollen from aquatic plants suggests locally damp conditions, with sufficient water for plants with submerged leaves to grow. Of significance also is an abundance of moss spores of *Sphagnum*, suggesting the moss was expanding at the site.

Conclusions and recommendations

- C.8.30 The assessed pollen data provide evidence of good recovery of pollen through a depositional sequence ranging in age from the early Bronze Age to the late Iron Age or Saxon period. Assessment has been interpreted to suggest variations in woodland cover, including dominance of lime woodland during the early Bronze Age, followed by a probable lime decline, together with expansion of open areas. Evidence from pollen and NPP data supports use of the land for pastoral and probable arable farming, during the middle and late Bronze Age. Local environments, inferred from pollen assemblages, include sedge fens and wetland areas capable of supporting aquatic plants. At some point within the later Iron Age to Saxon periods, there is evidence to support expansion of sedge fen communities, which may reflect higher water-tables, and possible re-growth of hazel-type scrub, possibly coinciding with the area no longer being used for farming activity. No evidence of marine environments was recorded.
- C.8.31 The sub-samples submitted at assessment provide a very coarse resolution palynostratigraphy; more precise data, providing clear indications of woodland changes and inferred potential human impact on the environment, as well as developments of sedge fen communities, perhaps reflecting local water-table changes, should be achieved through analysis of close spaced sub-sampling, at a minimum of 0.04m intervals, to fully document changes through the pollen profiles. These data could be integrated with previous pollen work from the Lower Thames region.

Monolith/Core Sample		10	10	10	10	38	38	39	OCA-WS307	OCA-WS307	OCA-WS405A	OCA-WS405A	OCA-WS414A	OCA-WS414A	OCA-WS414A
Preservation		Good	Good	Good	Good	Good	Good	Good	Mixed	Poor	Good	Mixed	Good	Mixed	Mixed
Potential		Y	Y	Y	Y	Y	Y	Y	N	N	Y	Y	Y	Y	N
Depth bgl (m)		0.56-0.57	0.66-0.67	0.77-0.78	0.94-0.95	1.16-1.17	1.38-1.39	1.67-1.68	1.75-1.76	2.38-2.39	1.87-1.88	2.57-2.58	1.79-1.80	2.62-2.63	2.97-2.98
Context		10702	10702	10703	10703	10705	10706	10707							
Trees/Shrubs															
<i>Alnus</i>	Alder	8	4	2	3	5	3	7			3	2	3	4	1
<i>Betula</i>	Birch	1	1	1	3	3	3	2					1		
<i>Quercus</i>	Oak	6	3	2	14	6	5	5			11	7	8	3	1
<i>Corylus avellana</i> -type	Hazel-type	49	10	6	8	23	20	11			18	14	5	10	6
<i>Fagus</i>	Beech		1	1	1	1	1	1					2		
<i>Fraxinus</i>	Ash						1	1			1				
<i>Pinus</i>	Pine		1	1	1										14
<i>Ulmus</i>	Elm	1	1		2	1		1							
<i>Hedera</i>	Ivy		1			1						1			
<i>Calluna</i>	Heather	2	1												
<i>Rubus</i> -type	Blackberry										1				
<i>Salix</i>	Willow	1					1						2		
<i>Sambucus</i>	Elder				1	1									
<i>Sorbus</i> -type	Rowans			1											
Rosaceae	Rose family											1			
<i>Tilia</i>	Lime					1		1	1		1	25	1	53	3
Crops															
<i>Cerealia</i>	Cereal-type		7	1	2	2	2	12	1		14		5	1	
Herbs															
Amaranthaceae/ Chenopodiaceae	Goosefoot family			4	1	1	1	2			1	1	2	1	1
Apiaceae	Carrot family	1			1										
<i>Artemisia</i>	Mugworts		1		1	1	1	1							
Asteraceae	Daisy family	4	3	1	1	10	3	3			6	3	6	1	2
Caryophyllaceae	Pinks family		8	3	1	3		1			2	1	2	1	
<i>Centaurea nigra</i>	Common knapweed		1												
<i>Cirsium</i> -type	Thistles	3	2			1							1		
Cyperaceae	Sedges		10	47	41	14	23	5	1			2	2	9	2
<i>Epilobium</i> -type	Willowherbs					1									
Fabaceae	Pea family					1								1	
<i>Mentha</i> -type	Mints		1										1		
<i>Persicaria maculosa</i>	Redshank							2			1				
<i>Plantago lanceolata</i>	Ribwort plantain	2	3	1		2	1	3			2	4	1	2	
Poaceae	Grasses	30	62	40	24	29	52	57	3	3	38	49	68	14	1
Ranunculaceae	Buttercups		1	1	1	1	3	1			1	3	1		
Rubiaceae	Bedstraws			1	2										
<i>Rumex</i> spp.	Docks/Sorrels		2	3	3	4	2						1	1	
<i>Stellaria</i> -type	Chickweeds		1	1											
<i>Succisa</i>	Devil's Bit Scabious		1		1	1									
<i>Taraxacum</i> -type	Dandelion- type		1	2		7	1	4			8	3	5	2	1
<i>Trifolium</i> -type	Clover-type													1	
	Total land pollen	108	127	119	112	120	123	120	6	3	108	116	117	104	32
	Traverses	1	1	2	2	2	1	1	10	10	1	4	2	5	10
Fern spores															
<i>Osmunda regalis</i>	Royal fern	1													

Monolith/Core Sample		10	10	10	10	38	38	39	OCA-WS307	OCA-WS307	OCA-WS405A	OCA-WS405A	OCA-WS414A	OCA-WS414A	OCA-WS414A
<i>Polypodium vulgare</i>	Polypodies	5		1		1	1	2			1	5	2	33	40
<i>Pteridium aquilinum</i>	Bracken			1	1	1	2				1	1	2	1	
Pteropsida	Monolete ferns	13	1	20	3	20	48		2	1	4	4	2	28	5
Aquatics															
<i>Lemna-type</i>	Duckweeds			1	1									1	1
<i>Myriophyllum spicatum</i>	Spiked water-milfoil							1							
<i>Myriophyllum verticillatum</i>	Whorled water-milfoil							1							
<i>Nymphaea alba</i>	White water-lilies											2			
<i>Sagittaria-type</i>	Arrowheads			1		3	3	1			2		1		
<i>Typha angustifolia</i>	Lesser Bulrush	8	4	6	4	28	13	30			20	6	20	1	
<i>Typha latifolia</i>	Bulrush	42		1	5	2	16				1		1		
Mosses															
<i>Sphagnum</i>	Moss spores	66	1								1				
Microscopic charcoal		9	1	1	2	3	3				1	1	2	7	2
Green algae															
<i>Botryococcus</i> HdV-766			1	1				1					1		
Oedogoniaceae HdV-166						3							1		
<i>Pediastrum</i> HdV-760															1
<i>Mougeotia</i> HdV-313			1		4	1	1		1		1				1
<i>Spirogyra</i> HdV-130/131		1	1		1	1		8			3	1	14	1	1
NPP															
HdV-114														12	4
HdV-128		1		1		1	1		6						
<i>Podospora</i> HdV-368						1						1	1	1	
<i>Sordaria</i> HdV-55A/B							1					1	1		
<i>Sporomiella</i> HdV-113														64	
Deteriorated															
Broken grains				1			1					2	1		2
Concealed grains		3		1	6	1		6		6	7			1	
Crumpled grains		1		2	1	2	2	1			5	6	6	6	8
Corroded grains				1											

Table 29: Pollen grain counts per sample by species

C.9 Summary of Geoarchaeological Fieldwork

By Liz Stafford

Introduction

- C.9.1 The geoarchaeological component of the evaluation works undertaken within Land Parcels (LPs) 47 and 48f-h, situated within the middle reaches of the Mar Dyke valley, comprised the targeted recording of sedimentary sequences exposed in trenches to supplement standard archaeological recording. In addition, the opportunity was taken to drill four transects of purposive boreholes (Transects 2-5) to investigate and sample the more deeply buried sequences present within the Mar Dyke floodplain. The deposits anticipated, based on a review of previous geotechnical data, included alluvium and potentially waterlogged organic deposits associated with palaeochannel sequences, as well as Pleistocene Head (and perhaps fluvial) deposits overlying London Clay bedrock.
- C.9.2 The focus of the evaluation was primarily to assess the geoarchaeological potential of the Holocene sedimentary sequences. The Pleistocene deposits are to be investigated in detail as part of a separate phase of purposive test pits and any information in this report is provisional, intended to provide additional information beyond that provided by geotechnical data.
- C.9.3 As stated in the WSI (which also covers the higher ground to the west of the Mar Dyke Basin across Land Parcels 43, 46 and 45a-d, detailed in OCA 2022a), the main aims of the evaluation were to:
- determine the degree of complexity of any surviving horizontal or vertical stratigraphy;
 - investigate areas where topography indicates the likelihood of deep deposit sequences for evidence of buried archaeological horizons and palaeo-environmental sequences;
 - investigate and record the extent, character and chronology of sedimentary sequences occurring within and adjacent to floodplains, as well as those contained within palaeochannels;
 - use the data obtained to refine existing geoarchaeological deposit models.
- C.9.4 More specific objectives were to:
- establish the extent, depth and complexity of alluvial, colluvial and slope deposits;
 - determine whether buried archaeological activity is preserved beneath or within any of these deposits;
 - clarify whether the wider Mar Dyke valley is of largely late Pleistocene date, or if earlier Palaeolithic channel deposits and sediments associated with the 'Ockendon meander' survive within it;
 - establish the former course(s) and complexity of the late Glacial and Holocene channel system of the river, and date its development;

- clarify whether there are successive sequences of channel deposits preserved within the river valley and examine evidence for activity along channel edges and across the wider alluvial floodplain;
- identify areas along the edge of the former palaeochannels and within the wider Mar Dyke floodplain, including any floodplain islands or areas which would have only received shallow seasonal inundation, that may have been used for human activity in the past.

C.9.5 The area under investigation is situated on the floodplain in the middle reaches of the Mar Dyke River valley, located to the east of the modern, canalised, course of the river. The BGS maps the underlying bedrock geology as London Clay throughout all the land parcels. The mapped superficial geology predominantly consists of alluvium, although Head deposits outcrop on the surrounding slopes and on low islands within the floodplain. One of these islands occurs prominently within the centre of LP 48h measuring approximately 400m wide. The study area has been previously reviewed as part of the scheme-wide Palaeolithic and Quaternary Deposit Model (PQDM) where areas were split into Palaeolithic–Quaternary (PQ) Zones (Wenban-Smith and Bates 2020). The current evaluation predominantly falls within Zone PQ-23a Orsett Fen, characterised by Head deposits outcropping on bedrock that have been eroded by fluvial activity or cold climate downcutting. Zone PQ-23a was assessed to be of low to moderate Palaeolithic potential.

Holocene geoarchaeological background

General

C.9.6 The route of the LTC crosses a tract of alluvium associated with the middle reaches of the Mar Dyke river immediately north-west of Orsett, Essex. Here the floodplain topography forms a large flat basin underlain by London Clay, previously occupied by Orsett and Bulphan Fens, mostly drained during the medieval period. The lower reaches in the vicinity of Stifford and Purfleet have been the subject of considerable geoarchaeological study, particularly the fossiliferous Pleistocene gravels associated with the ‘Ockendon meander’, a former course of the River Thames. There are areas of the scheme where Pleistocene deposits are likely to be exposed, for instance alongside the M25, and LTC has appointed a Palaeolithic specialist, Francis Wenban-Smith and geoarchaeologist Martin Bates, to provide a strategy for the investigation and recording of these deposits where the scheme impacts upon them. This is discussed in the Palaeolithic and Quaternary Deposit Model (PQDM), and Preliminary Assessment of Archaeological Potential (Wenban-Smith and Bates 2020).

C.9.7 The Mar Dyke valley floor alluvium (Holocene) was investigated during improvements to the A13 further downstream in the vicinity of North Stifford, where it reached over 5m in thickness (Wilkinson 1988). The sedimentary sequences at this location were complex, comprising intercalated freshwater peat and estuarine silt clay units dating back to the middle Holocene. Diatoms from the basal silts indicated estuarine conditions prevailed at this location, and a radiocarbon date of 4780-4380 cal BC (HAR 4522, 5740 ± 80 BP) from the top of this unit correlated it with Devoy’s Thames II marine transgression (Devoy 1979). The lower wood peat, formed in freshwater alder carr, was correlated with Devoy’s Tilbury III regression (ibid.) and provided pollen evidence for the early Neolithic elm decline. Evidence of human activity associated with the peat consisted of wood charcoal and a late Neolithic to early

Bronze Age flint knife from the top of the unit. Later prehistoric burnt flint, pottery and charcoal was also recovered from the overlying sediments. Upper peat units were radiocarbon dated to the late Roman to Saxon periods, although altitudes diverged from the Devoy model, possibly due to local micro-topography of the valley floor (Wilkinson 1988, 106).

- C.9.8 In contrast, the sedimentary sequences associated with the middle reaches of the Mar Dyke have been subject to little geoarchaeological study. The current course of the Mar Dyke has been realigned and straightened and prior to the current project, the only borehole data available from the BGS online dates from the 1970s (the Mar Dyke Improvement Scheme) and consists of hand-written logs without overall interpretation. The descriptions in the boreholes vary with alluvial type deposits (silt and clay) noted at c 1.5 to >4.0m in thickness. In several locations the alluvium was described as peaty with laminations and waterlogged wood. Gravel was noted in the base of some of the sequences; where absent the presence of selenite or gypsum crystals may indicate tertiary bedrock, although the transition with the overlying alluvium is not always clear.
- C.9.9 The Mar Dyke was still tidal up to Stifford bridge in the eighteenth century and navigable to Orsett Hall and into the fens (Allison 1966, 11). While it is possible that it was tidal even further upstream earlier than this, it is more probable that the sequence of deposits in the middle reaches will be shallower and formed in differing depositional environments than the deep estuarine sequences recorded downstream towards the Thames confluence (Bates and Stafford 2013; Wilkinson 1988).
- C.9.10 The Holocene sedimentary sequences associated with the floodplain of the Mar Dyke where it is crossed by the Lower Thames Crossing scheme have the potential to preserve buried archaeological and palaeo-environmental remains of significance. The current course of the Mar Dyke has been realigned and straightened, but clear evidence for former channels is visible on LiDAR data and further palaeochannels along with floodplain islands may lie buried at depth.

LTC Geotechnical and LiDAR data

- C.9.11 Examination of a tranche of recent LTC geotechnical and LiDAR data for the wider Mar Dyke valley was undertaken prior to the evaluation commencing which provided some additional information on the buried topography and the depth and character of sedimentary sequences. The results have been outlined in detail in the WSI (OA 2021, fig. 4b).
- C.9.12 In summary, for LPs 47 and 48f-h, detailed analysis of the LiDAR data identified the presence of a complex of palaeochannels meandering across the floodplain (ground surface average 3m OD), apparently encircling a large low-lying island or promontory (ground surface reaching up to c 4.5m OD) that corresponded to an outcrop of Head mapped by the BGS (OA 2021, figs 2, 4a and 4c). On the south side of the island in LPs 48f and 48g a single very well-defined palaeochannel was evident, measuring approximately 80-180m wide. The widest expanse appeared to cut into the northern bank of the island in an arc, perhaps suggesting at this location a deep meander, or the presence of more than one channel. A slight rise in ground levels in the centre of the palaeochannel also suggested the possible presence of deeper channels either side. To the north-east of the island a single well-defined meandering palaeochannel was noted, albeit narrower at c 25-30m. To the north, this becomes less well defined

with a large low-lying area containing a complex of channel meanders and a small possible island. On the western side of the main island in LP 48h ground levels are a little higher than the surrounding floodplain at c 3.8m OD, which may suggest at one point the island may have formed a promontory, a lobe of head/solifluction deposits extending from the western slopes.

- C.9.13 Subsurface data derived from geotechnical interventions indicated the wide well-defined palaeochannel on the south side of the island extended to depths of c 4m and contained thin units of organic silt clay within 1.5m of ground surface, in places described as peaty. Locally thicker deposits of organic silt clays were noted either side of a bedrock high in the centre of the channel, apparently confirming the evidence from the LiDAR data for the presence of two deeply incised buried channels.
- C.9.14 Interpretation of the sequences to the north of the island were less clear, partly due to the difficulty in separating weathered London Clay from alluvium and Head, all of which were invariably described as dense orangey brown clay. There were few records of coarser clastic sediment – sands and gravels- within the geotechnical logs and no indication of extensive tracts of blanket peat. Only one intervention recorded organic sediment to the north of the island with sequences dominated by minerogenic clay alluvial sediment to depths of up to c 4m.
- C.9.15 Records from the highest elevations within LP 48h confirmed the island was underlain by ‘Head’ deposits described as orangey brown clay directly underlying the modern ploughsoils at just over c 4.5m OD.

Method

Boreholes

- C.9.16 The programme of purposive boreholes comprised the drilling of 43 boreholes in four transects (Transects 2-5, Figs 14-17, Table 30). The borehole transect numbers are a continuation of those from LP 45 (reported upon separately, OCA 2022a) and begin in this evaluation at Transect 2. The primary aim of the borehole survey was to investigate deposits at depth and to recover intact core samples. The boreholes were intended as contingency in the event difficult wet ground conditions precluded sampling from trench faces, or if deposits of interest extended below 2m BGL (eg. Transects 3 and 4).

Transect	Borehole	Easting	Northing	Elevation (m OD)	Total Depth (m)
Transect 2	OCA-WS201A	562118.968	183259.863	3.66	3
	OCA-WS202A	562124.813	183019.668	3.79	2
	OCA-WS203A	562130.189	182809.980	2.92	3
Transect 3	OCA-WS301	562023.125	183541.069	3.18	5
	OCA-WS302	562031.269	183528.765	3.06	5
	OCA-WS303	562039.890	183515.746	3.10	5
	OCA-WS304	562048.191	183502.857	3.30	4
	OCA-WS306	562068.604	183476.008	3.58	5
	OCA-WS307	562076.313	183464.753	3.28	4
	OCA-WS308	562084.981	183452.347	3.14	4
	OCA-WS309	562093.520	183440.012	3.12	3

Transect	Borehole	Easting	Northing	Elevation (m OD)	Total Depth (m)
	OCA-WS310A	562102.040	183427.491	3.08	4
	OCA-WS311	562110.241	183415.495	3.06	4
	OCA-WS312	562119.060	183402.622	2.96	4
	OCA-WS313	562127.756	183390.098	3.00	4
	OCA-WS314	562136.098	183377.672	3.03	4
	OCA-WS315A	562144.527	183365.267	3.04	4
	OCA-WS316	562153.205	183352.996	2.99	5
	OCA-WS317	562161.756	183340.508	3.04	4
	OCA-WS318	562170.793	183328.466	3.10	5
	OCA-WS319	562180.754	183316.997	3.12	5
	OCA-WS320	562187.467	183303.150	3.19	5
	OCA-WS321	562196.085	183290.942	3.49	4
	OCA-WS323A	562255.289	183204.283	4.25	3
Transect 4	OCA-WS402	562447.180	182987.253	3.64	3.7
	OCA-WS403	562451.152	182975.502	3.20	4
	OCA-WS404	562457.009	182961.588	2.76	5
	OCA-WS405A	562462.815	182946.727	2.89	5
	OCA-WS406	562468.301	182932.479	2.93	5
	OCA-WS407	562474.217	182918.454	2.89	5
	OCA-WS408	562479.190	182904.750	2.91	4
	OCA-WS409	562481.308	182889.046	2.82	4
	OCA-WS410	562489.763	182876.412	2.83	4
	OCA-WS411	562495.335	182862.235	2.82	4
	OCA-WS412	562500.794	182848.230	2.88	5
	OCA-WS413	562505.780	182834.166	2.88	4
	OCA-WS414A	562510.962	182820.610	2.91	5
	OCA-WS416	562518.773	182795.747	3.58	3
Transect 5	OCA-WS501	562267.240	183406.952	3.52	5
	OCA-WS502	562267.228	183391.862	3.22	4
	OCA-WS503A	562266.913	183378.818	3.13	5
	OCA-WS504	562267.130	183362.052	3.31	4
	OCA-WS505	562267.039	183347.008	3.50	4

Table 30: Summary of borehole locations

C.9.17 Transect 2 (Fig. 14) is aligned broadly north south to the west of the island promontory to investigate the area immediately east of the current Mar Dyke channel. This transect was originally intended to have boreholes placed at 100m intervals to investigate whether a deep early channel existed in this area. However, during the evaluation, it became apparent that the London Clay bedrock lay at comparatively shallow depths, frequently exposed within the footprint of the trenches. For this reason, the number of boreholes was significantly reduced (relocated to Transect 5, see below). Three locations were drilled with full core recovery (OCA-WS201A-OCA-WS203A). At each location a second set of cores was recovered and retained unopened in the event they may subsequently be required by the Palaeolithic specialist for OSL dating (the primary borehole numbers suffixed A, the second set intended of OSL dating suffixed, B).

- C.9.18 Transects 3 (OCA-WS301-OCA-WS23A, Fig. 15) and 4 (OCA-WS402-OCA-WS16, Fig. 16) were positioned to provide detailed profiles of the palaeochannel zones both north and south of the island. Given the anticipated complexity of the sequences, the array was designed to sample with continuous core recovery at broadly 15m intervals. The alignment was selected to coincide broadly with the centre line of scheme. Duplicate borehole cores were recovered at five locations should OSL dating be required from minerogenic sediments (relocated from Transect 2). This was an additional contingency in the event radiocarbon dating of the channel sequences was not possible and was based on initial observations of the sequences as the drilling progressed (OCA-WS310, OCA-WS315, OCA-WS323, OCA-WS405, OCA-WS414).
- C.9.19 Transect 5 (Fig. 17) was an additional set of boreholes (relocated from Transect 2) to investigate the palaeochannel associated with a timber stake structure identified in Trench 14, c 110m east of Transect 3. This structure has subsequently been radiocarbon dated to the early Iron Age.
- C.9.20 The boreholes were drilled by Wheeler Site Investigation and Dynamic Sampling, under the supervision of an OA Geoarchaeologist, using a terrier type rig (windowless sampler). The rig can extract intact 1m long sleeved cores approximately 100mm wide. The boreholes were drilled until the upper levels of the London Clay bedrock had been reached, in order to enable the recovery of a complete sequence of deposits.
- C.9.21 Drilling locations were set out by an OCA Surveyor, and each location was CAT scanned prior to intrusive work commencing. Each borehole was cased to prevent collapse and to minimize contamination from deposits already drilled. On completion of the drilling, the boreholes were backfilled with bentonite pellets.

Trenches

- C.9.22 Trenches predominantly within the floodplain/palaeochannel zones were generally excavated to a maximum of 2m depth BGL, which in some cases was sufficient to expose weathered bedrock. Machine dug test pits extended the depths to 3m at selected locations to investigate deeper sequences for the presence of archaeological remains, although very poor ground conditions, flooding and edge collapse precluded this in every trench. Trench flooding also limited visibility and access to record and sample the exposed sequences in several trenches, particularly in the large palaeochannel in the southern part of LP 48f and LP 48g.
- C.9.23 The recording of the sediments comprised the detailed geoarchaeological logging of one or more 1m wide sections in trenches considered to be broadly representative of the site sequences or where stratified archaeological remains were identified. Each geoarchaeological log was allocated a section number and located relative to the National Grid and Ordnance Datum. The sediment sequences were recorded from ground surface on a geoarchaeological log proforma with each layer allocated a unique context number. Preliminary interpretations of associated depositional processes were also recorded on the logs.
- C.9.24 Overall, 188 section logs were completed. Following stratigraphic analysis, 70 of these logs have been incorporated into borehole Transects 2-5 (Figs 14-17). An additional three transects (Transects 12-14, Figs 18-20) have been created from

trench logs. These transects continue the numbering from Land Parcel 45 (OCA 2022a).

C.9.25 Transect 12 is aligned west-east across the northern part of LP48, intersecting with Transect 3 and incorporates palaeochannel sequences as well as a small floodplain island where a LBA cremation deposit was excavated. Transect 13 is also aligned west-east across the main part of the island, incorporating the floodplain margins and palaeochannel to the east. Transect 14 is located in the southern part of the site to illustrate the sequences along the north bank of the main palaeochannel on the south side of the island.

C.9.26 Table 31 summarises the location, elevation and total depth of the trench sections included in Transects 1-5 and Transects 12-14.

Transect	Section	Easting	Northing	Elevation (m OD)	Total Depth (m)
2, 3, 12	100	562058.948	183434.491	3.1787	1.84
2, 3, 12	101	562050.963	183442.589	3.139554	1.93
12	200	562135.874	183444.885	3.1	3
12	300	562163.430	183439.517	3.169334	1.82
12	301	562162.875	183452.136	3.06702	3
12	400	562216.322	183450.447	3.097485	1.89
12	401	562233.412	183452.549	3.53549	1.9
5, 12	601	562276.870	183442.637	3.546965	1.95
5, 12	602	562270.732	183455.120	3.518238	1.98
12	700	562347.201	183453.093	3.446103	1.97
12	701	562370.890	183429.665	3.35	2
2	900	562063.890	183384.197	3.145218	2.17
3	1000	562086.896	183398.635	3.087469	1.8
3	1001	562095.102	183389.892	3.052323	3.2
3	1100	562130.440	183349.918	3.0727	1.7
3	1101	562122.602	183358.123	3.026242	1.71
5	1400	562276.546	183369.311	3.2	1.95
5	1401	562276.546	183365.311	3.2	3.3
2	1601	562069.789	183330.718	3.078	1.86
3	1700	562154.277	183321.070	3.031768	1.72
2	1800	562085.652	183287.871	3.401528	2
3	2000	562202.165	183259.577	3.865613	1.34
3	2001	562190.184	183275.667	3.8	2.16
13	2700	562148.829	183178.465	3.757	2
13	2800	562215.994	183184.989	4.100386	2
13	2801	562197.678	183184.192	3.896601	2
13	2900	562248.290	183181.363	4.3	2
2, 13	3200	562121.581	183134.449	3.76369	0.9
2, 13	3201	562100.877	183136.651	3.836676	0.9
13	3500	562297.478	183181.025	4.297112	0.92
13	3700	562400.304	183205.820	3.575418	1.6
13	3701	562412.816	183213.664	3.291773	1.91

Transect	Section	Easting	Northing	Elevation (m OD)	Total Depth (m)
13	3702	562420.414	183214.438	3.212839	1.12
13	3800	562424.585	183240.304	3.295749	2
13	3801	562441.862	183240.223	3.29	3
13	4400	562347.481	183133.229	4.379433	0.49
13	4500	562369.407	183164.587	4.110584	0.44
2	4801	562100.725	183051.188	3.815795	1.68
14	7200	562504.018	183084.559	4.079996	1.16
14	7300	562066.132	182871.139	3.061423	1.98
14	7301	562076.341	182881.796	3.097225	1.99
2	7400	562111.344	182832.635	2.908212	2.1
2	7401	562112.466	182847.126	3.078701	2.01
2, 14	7500	562113.911	182922.990	3.354892	2
2, 14	7501	562130.437	182926.720	3.411369	1.71
14	7600	562158.973	182886.229	3.639906	2.6
14	7601	562171.794	182892.216	3.722805	1.1
14	7700	562177.690	182932.641	3.741103	1.95
14	7701	562191.561	182936.734	3.82119	1.85
14	7900	562227.761	182835.754	3.514287	1.85
14	7901	562221.788	182823.507	3.41591	2.6
14	8000	562222.100	182940.057	3.884	2
4, 14	8602	562416.167	183006.901	4.133171	1.04
14	9002	562414.301	182974.923	4.03	0.6
14	9101	562330.621	182899.756	3.584014	2.8
14	9300	562415.053	182933.572	3.581702	3
14	9500	562476.638	183032.011	3.814611	1.96
14	9501	562460.926	183026.977	3.932326	2
14	9601	562508.174	183049.799	3.924928	3
4	10700	562466.320	182880.193	2.891415	2.15
4	10701	562460.090	182894.683	2.908313	1.9
4	10702	562472.867	182873.053	2.914	3
4	10900	562507.092	182809.045	2.945321	1.84
4	10901	562513.137	182803.844	3.145445	2.08
4	10902	562516.696	182800.895	3.259772	2.14
4	10903	562519.636	182798.068	3.368863	2
4	9400-P1	562442.608	182970.903	3.3291	0.8
4	9400-P2	562443.580	182967.596	3.253	1.3
4	9403-P1	562446.700	182955.750	2.89	1.8
4	9403-P2	562447.254	182953.827	2.85	3

Table 31: Summary of selected geoarchaeological section locations

C.9.27 Sediment recording followed Historic England guidelines (2015b) and Jones *et al* (1999), and typically included a description of texture, compaction, colour, clast size and abundance, bedding structures and other inclusions (eg. charcoal), post-depositional features (eg. rooting, mottling, mineralisation), and the nature of sediment contacts (eg abrupt, diffuse, irregular).

C.9.28 Sampling of the sediment sequences in the trenches was carried out in accordance with Historic England guidelines (2011) and was targeted to allow for representative channel/alluvial sequences through 10L bulk samples (mainly to assess for the preservation of waterlogged plant remains (WPR) and molluscs) and monoliths for further sediment description and subsampling for radiocarbon dating and microfossils (Appendices C.5, C.6, C.7 and C.8). Priority was given to any artefact rich contexts where larger bulk samples up to 40 litres were also recovered for assessment of charred plant remains (CPR) and recovery of micro-artefacts (see Appendices C.1 and C.2 this report). Along with the monoliths, OSL samples were also taken from some of these sequences to allow for further analysis and dating should this be required. Where sampling was carried out, the log proforma was accompanied by a measured section drawing on permatrace marking the position of the samples. Table 32 summarises the samples collected from the sediment sequences in the evaluation trenches.

Trench	Section	Bulk	Monolith	OSL	Total
7	701	12	4	5	21
14	1400	10	6	7	23
16	1600	3		4	7
19	1901	1			1
73	7301	2	4	4	10
86	8602		2	4	6
94	9402	2	5	3	10
94	9403	5	1	2	8
97	9700	4			4
102	10200	2		3	5
107	10700	4	4	5	13
109	10901	5	5	8	18
111	11100	6		3	9
111	11101	1			1
	Total	60	31	48	139

Table 32: Summary of trench samples recovered from sediment sequences

C.9.29 Following the completion of fieldwork, the lithological information from the logs was entered into geological modelling software (Rockworks17) to allow the identification and broad correlation of a series of sediment facies. This enabled the creation of digital transects illustrating the key deep trench profiles across the main valley sequences and the location of corresponding recovered samples and associated archaeological finds/features.

C.9.30 Following preliminary stratigraphic analysis, several key sequences from borehole cores and monoliths were targeted for subsampling. This included subsampling for radiocarbon dating and assessment of WPR, pollen, diatoms, ostracods and foraminifera. In total 12 horizons were subsampled for radiocarbon dating, either from waterlogged seeds extracted from bulk samples or, in the absence of seeds, sediment subsampled from monoliths/cores (both humic and humin fractions were dated in this instance, see Nicholson, Appendix C.5). The subsamples submitted for microfossil assessment are summarised in Table 33. Due to poor recovery of the upper peaty sediments in the boreholes, the monoliths from Trenches 107 and 14 were subsampled in Transects 4 and 5. The purpose of the subsampling was to

evaluate the general preservation status of a range of palaeo-environmental proxies, the degree of waterlogging and overall, address the potential of the sequences to provide well-dated and detailed landscape reconstructions. In addition, the diatoms, ostracod and foraminifera assessments were particularly aimed at identifying any tidal influence within the channel system. The detailed specialist reports for each category are reported above.

Transect	Section/Core	14C	Diatoms	Ostracods/ Foraminifera	Pollen	WPR
3	OCA-WS307	1	2		2	
4	10700	3	7	5	7	4
4	OCA-WS405A	2	2	2	2	3
4	OCA-WS414A	2	3	2	3	2
5	1400	2				8
5	OCA-WS503A	2				2
	Total	12	14	9	14	19

Table 33. Summary of subsample numbers from monoliths and cores, and bulk samples (WPR) from key sediment sequences

Results

C.9.31 Overall, several broad sediment facies were recorded across the site. The results are presented below and are discussed in relation a series of composite transects incorporating key trench and borehole profiles.

- I. **Topsoil** - modern ploughsoils.
- II. **Subsoil** – thin clayey interface subsoils beneath topsoil/ploughsoils, derived from underlying alluvium and Head-Brickearth deposits
- III. **Alluvium** – Fine-grained silts and clays occurring as overbank alluviation and minerogenic silting with channels. Can be massive and homogenous to finely laminated, a number of sub-facies were identified:

IIIa - Alluvium (oxidised) – forming the upper parts of the sequence on the floodplain, oxidised orange brown, but softer and greyer than the brickearth deposits. Contains one or more thin intercalated peaty /stabilisation horizons of later prehistoric and historic date.

IIIb - Alluvium (laminated) – as above but with some evidence of bedding and ephemeral horizontal laminations.

IIIc - Alluvium (detrital) – very pale brown silt clay with some organic detritus and moderate to heavy rooting with Fe precipitation. Tends to occur ubiquitously within the low-lying floodplain north of the island promontory filling in the upper parts of palaeochannels and beyond – shallow reed swamp?

IIId – Alluvium (gleyed) – bluish and greenish grey silts and clays, often with some detrital material and flecking, associated particularly with lower channel profiles, mostly homogenous with little bedding.

IIIe – Gravelly alluvium (gleyed/channel) - as above but with some clast content including reworked organics (rip-up clasts), infrequent and very localised to the base of channels sequences.

- IV. **Organic stabilisation horizons** – deposits of variable appearance and distribution, that can be divided into several sub-facies:
- IVa - Peaty silts and clay** – occurring as thin to very thin, often continuous beds, very dark brown to black and humified. Very low energy relatively stable but short lived horizons. Frequently exhibited a minerogenic component within the matrix, and also as thin alluvial lenses indicating continued pulsed input. Occasionally, observed to be heavily disturbed and eroded within and adjacent to the main channel systems.
- IVb - Organic silt and clay** – organic, often detrital, mid to dark grey or reddish brown silts and clays. Shallow low-energy channel/wetland environment with vegetation.
- IVc - Organic silt and clay (laminated)** – as above but displaying horizontal laminations, often located above detrital alluvium (hydrosere?), bedding suggestive of low energy marginal/edge environments.
- V. **Weathered/Leached horizons** - firm but friable pale blueish or greenish grey to white fine clay silt deposits. Largely stoneless with frequent post-depositional weathering features (leaching, iron mineralisation, and rhizome calcretes) and evidence of bioturbation (rooting) from overlying deposits. Predominantly occurs weathered into Unit VI and VII, sealed by alluvium or an alluvial subsoil. Charcoal flecks maybe present albeit infrequent and artefactual material maybe recovered from this horizon.
- VI. **Brickearth-type (mapped by the BGS as Head)** - fine-grained, dense, but locally soft to firm, yellowish brown and strong brown clays, clay silts and silt clays of probable polygenetic origin and potentially of both Pleistocene (late Glacial) and early Holocene date. Generally stone-free or with limited clast content (gravel stringers) in the upper parts of the sequences. These deposits may derive in part from alluvial processes, perhaps a fining- up sequence (eg. high clay content) and erosion/weathering of London Clay bedrock. Although locally a higher silt content may also point to some deflation/aeolian inputs. Structural bedding is detected at depth with localised thin ephemeral darker grey (stabilisation?) horizons, seen to be organic and peaty in OCA-WS307 and radiocarbon dated to the late Glacial or early Holocene. Down-profile this unit exhibits increasing clast content and some fine bedding suggestive of input from down-slope processes (Head). Locally, in the absence of gravelly facies, the lower interface with weathered brown London Clay can be ambiguous.
- VII. **Gravelly Head** – variable deposits of dense clayey poorly sorted matrix supported gravel. Cold climate probable solifluction slope deposits and locally reworked fluvial gravel. Predominates in the western and northern parts of the site abutting footslopes of higher ground, frequently beneath Unit VI. At depth possibly a lateral equivalent of Unit VII.
- VIII. **Sand and gravel** – loose, coarse grained Pleistocene (fluvial?) gravel, frequently clast supported with occasional beds of coarse sand (ripple bedded). Located at depth below the Unit VI, particularly on the southern margins of the island promontory.
- IX. **Weathered/soliflucted bedrock** – in its weathered form the bedrock appears as a dense reddish brown, sometimes mottled blush grey and olive brown, silty

clay and clay. It includes frequent degraded fossils appearing as clasts and lenses along with gypsum crystals. Frequently it retains faint laminations and local sand partings. Occasionally it appears puddled, often fissured and with polished surfaces (slickensides). Here, it is, probably effected by hydrological change (swell/shrink) and cryoturbation (freeze/thaw). Mass movement may also be involved adjacent to slopes (solifluction lobes/ landslips) as indicated by rare poorly sorted clasts up to cobble size within an overall chaotic/fissured structure.

- X. **London Clay Formation (LCF) bedrock** - unweathered, the LCF appears as an unmistakably very dense bluish grey or dark grey silty clay, frequently with fine but clear horizontal laminations, sand partings and gypsum crystals.

Transect 2 (Fig. 14)

- C.9.32 Transect 2 is aligned broadly north-south to the west of the main island and immediately east of the current Mar Dyke channel. Here, current ground levels are slightly lower (c 3.8m OD) than those on the island (max. of c 4.8m OD) but above the floodplain (c 3.0m OD), forming what appears to be denuded interfluvium with the higher ground to the west (LP45, c 4.5m OD). This area was specifically targeted to investigate whether a buried N—S channel was present at depth. Three boreholes were drilled in this area (OCA-WS201A-OCA-WS203A) accompanied by several evaluation trenches. Figure 14 illustrates that the surface of the underlying weathered bedrock (Unit IX) occurs at relatively high elevations between Trenches 18 and 75, above c 2.5m OD, reaching a high of over 3m OD in Trench 32. There is no indication of a palaeochannel at this location. Deposit sequences invariably comprise Unit VI brickearth capped with a thin veneer of alluvium (Plate 11). To the north and south of the interfluvium, ground levels reduce from c 3.8m OD to c 3.0m onto the floodplain. Here a complex series of intercalated minerogenic alluvial and organic/peat deposits are present of similar character to those described for Transects 3 and 4 (below). In Trench 16 (Section 1601) these reached to almost 1.5m BGL with thick deposits of detrital alluvium (Unit IIIc). This alluvium was invariably sealed by peat (Unit IVa) and, above c 2.5m OD, oxidised alluvium (Unit IIIa). A thin peaty lens was recorded, intercalated within this upper alluvium at c 0.5m BGL (Plate 12).

Transect 3 (Fig. 15)

- C.9.33 Transect 3 was positioned to provide a detailed profile of the palaeochannel zones north of the main island promontory. Aligned NW-SE, it includes Boreholes OCA-WS301 to OCA-WS323A and incorporates Trenches 1, 10, 11, 17 and 20. Figure 15 illustrates London Clay bedrock (Unit X) and weathered bedrock (Unit IX) at the base of the sequences. Across most of the transect the surface of the weathered bedrock occurred at similar, though slightly undulating elevations of between -0.5m and 0.5m OD. However, elevations rise significantly south of OCA-WS320, reaching c 2.4m OD in OCA-WS323A, located at the northern edge of the main island promontory.
- C.9.34 Overlying the weathered bedrock are relatively thin deposits of gravelly Head (Unit VII), sealed by significant thicknesses of brickearth (Unit VI) (Plate 13). Localised faint horizontal bedding was noted intermittently within the brickearth at depth in several the boreholes, slightly greyer lenses that may indicate stabilization horizons. In Borehole OCA-WS307 one deposit at 2.29-2.44m BGL was notably more organic and peaty (Plate 14). A radiocarbon date from a 10mm dark humic layer within this deposit suggests deposition either in the late Glacial at 11220-11130 cal BC (Allerød

interstadial), or the very early Holocene at 9270-8930 cal BC (Fig. 21 and Appendix C.5). Unfortunately, pollen and macroscopic plant remains were poorly preserved in this deposit and diatoms were entirely absent.

- C.9.35 Regarding the overlying Holocene alluvial and peat deposits, two deep incisions into the brickearth deposits indicate the location of palaeochannels, recorded in OCA-WS308 to OCA-WS310A, and OCA-WS316. These were largely filled with gleyed alluvium (Unit III d), although OCA-WS316 did contain more organic units as well as a gravelly unit with reworked detrital material towards the base (Plate 15). This latter palaeochannel based on the LiDAR data, is probably equivalent to that recorded in Transect 5, OCA-WS503A (described below), the base of which was dated to the middle Bronze Age at 1380-1120 cal BC (Fig. 21; Appendix C.5). The base of the channel in OCA-WS316 occurred at c -0.2m OD, whereas that in OCA-WS503A occurred at a similar elevation of -0.4m OD.
- C.9.36 Throughout the remainder of the Transect 3, gleyed and detrital alluvium (Units III d and III c) infill the lower lying area, overlain by a relatively continuous unit of peat, a very similar sequence to that in recorded Trench 16 (Plate 12). This also included a upper thin peaty stabilisation horizon at c 0.5m BGL. At the southern end of the Transect in Trench 20, numerous worked flints were recovered from the base of the alluvium (context 2003) of both Mesolithic to early Neolithic and later prehistoric date.

Transect 4 (Fig. 16)

- C.9.37 Transect 4 was positioned to provide a detailed profile of the main palaeochannel south of the main island promontory. Aligned broadly N-S, it includes Boreholes OCA-WS402 to OCA-WS416. and incorporates Trenches 94, 107 and 109. Figure 16 illustrates London Clay bedrock (Unit X) and weathered bedrock (Unit IX) at the base of the sequences. Across most of the transect the surface of the weathered bedrock occurred at similar elevations of c 1m OD apart from where it is incised by channels. However, elevations rise significantly in the vicinity of Trench 109, reaching c 2m OD in OCA-WS416, located on the rising ground on the southern bank of the main palaeochannel.
- C.9.38 Overlying the weathered bedrock on the north bank of the palaeochannel are relatively thin deposits of sand and gravel (Unit VIII), sealed by significant thicknesses of brickearth (Unit VI). The basal gravel was exposed in section in nearby Trench 97 (Plate 16). In Trench 86 on the higher ground at the northern end of the transect an extensive flint scatter (Fig. 6; Plate 7) was recorded, extending c 1m into the top of the brickearth. It is possible this scatter is preserved within a subsoil hollow within this trench. The flint was of late Mesolithic date, although early Neolithic pottery was also recovered towards the top of the sequence.
- C.9.39 Regarding the main palaeochannel identified on the LiDAR, the borehole survey confirmed the presence of two deep incisions, either side of a bedrock high in the centre. These incisions occurred at c 0.1m OD in the north and c -0.3m OD in the south – similar to the base of the channels recorded in Transects 3 and 5. The channels were filled with gleyed and intercalated organic silt clays (Units III d and IV b). There was no indication of coarser-grained sand or gravel deposits in the base of these channels in the boreholes.

- C.9.40 Organic deposits towards the base of each of the channels in Transect 4 were radiocarbon dated. To the south (the slightly deeper channel) deposits at 2.63m BGL in OCA-WS414A were dated to the early Bronze Age at 2200-1970 cal BC and 1890-1640 cal BC (Plate 17; Fig. 21; Appendix C.5). Pollen assemblages were well-preserved and contained abundant tree pollen of lime, with some hazel-type and alder, suggestive of 67% arboreal cover in the catchment. Open areas contained grasses and a range of herbs including those which may occupy disturbed ground or waste areas. Fungal spores suggest the presence of grazing herbivores. Pollen from aquatic plants was rarely recorded but includes occurrences of bulrush and duckweed. (see Rutherford, Appendix C.8 this report). The waterlogged seed assemblage was dominated by water crowfoot, although rushes and spike rushes were also well-represented. Small fragments of degraded wood are also present along with fragmentary insect remains and occasional caddisfly larval cases (see Cook, Appendix C.2).
- C.9.41 To the north, similar deposits at 2.56-2.61m BGL in OCA-WS405A (Plate 18) were dated to the middle Bronze Age at 1510-1400 cal BC (ibid). Here, pollen assemblages indicate an expansion of open, grassy areas and decreasing woodlands in the catchment to 43%, suggesting potential woodland clearance activity, perhaps for pastoral agriculture. In terms of aquatics, pollen of bulrush was commonly recorded along with spores of green algae. Waterlogged seeds include pondweed, water crowfoot, water plantain, water-dropwort, and spike rushes. Most of the seeds are from plants which are typical of marshy areas, in slow moving or standing water or on the banks of rivers, streams, ponds and ditches. Fragmentary insect remains were common as well as caddisfly larval cases.
- C.9.42 In both boreholes OCA-SW405A and OCA-WS414A, and across the bedrock high in Transect 4, the upper parts of the deeply-incised channels were infilled with gleyed alluvium, organic clay silt (sometimes laminated) and peaty deposits (detrital), the latter stretching across the width of the transect averaging 1.3m to 1.6m OD. In Borehole OCA-WS414A these peaty deposits were dated at 1.43-1.48m BGL to 910-800 cal BC in the late Bronze Age. In OCA-WS405A similar deposits at 1.40-1.45m BGL were dated to 930-810 cal BC.
- C.9.43 The upper sediment sequence in Transect 4 was also investigated in detail in Trench 107 (Section 10700), lying directly above the bedrock high in the centre of the main palaeochannel (Plate 19). Here, a peaty clay silt (context 10706) at 1.47m BGL and correlated with the upper deposits dated in the adjacent boreholes, produced a similar later prehistoric radiocarbon date of 1420-1230 cal BC and 1050-840 cal BC (Fig. 21; Appendix C.5). It was noted in Section 10704 that the surface of context 10706 was heavily disturbed (Plate 20), as were similar deposits in Trench 97 where large clasts of peat appeared to have been eroded out (Plate 21). Here, there were clear fine sandy silt laminations and bedding structures within the channel fills. Within the gleyed alluvium, organic clay silt, and overlying peat sealing the incised channels and dated to the middle to late Bronze Age, subsamples contained pollen suggesting a further reduction in woodland cover and expansion of open areas. Several possible cereal-type grains (largely of wheat/oats and some barley) were recorded which may suggest that arable farming may have been practiced locally. Pollen from aquatic plants along with green algae support the presence of fresh water, with oospores indicative of quiet bodies of shallow, perhaps slow moving or standing water (Appendix C.8). The waterlogged seed assemblage was similar to that described

above with a range of wetland plants. Water flea (*Daphnia*) ephippia and bryozoan statoblasts indicate the likelihood of variable water levels (Appendix C.2).

- C.9.44 Up-profile across Transect 4, spanning the width of both incised channels and the bedrock high lay a c 1.5m thick sequence of organic clay silts, including a further peaty horizon averaging 1.9-2.1m OD and dated in Trench 107 (context 10703) to the early Iron Age at 750-400 cal BC. This sequence was invariably sealed by oxidised orangey brown silt clay alluvium. Pollen samples from Trench 107 suggest the organic clay silt (contexts 10705/3) was deposited locally in a predominantly open, possible sedge-fen environment, with regional woodland at 30% comprising oak, and hazel-type with alder, birch, elm and beech. Pollen from the peat (context 10703) suggests by the early Iron Age regional arboreal cover was reduced to just 12%, with further development of sedge-fen communities and open grassy or meadow areas. The deposition of the overlying alluvium (context 10702) coincides with slightly higher proportions of tree and shrub pollen and a reduction in sedge fen communities. Here, grasses are dominant, along with plants associated with disturbed ground and evidence of possible cereal cultivation (Appendix C.8). Preservation of waterlogged seeds appeared to be much poorer in this upper sequence from Trench 107 and limited to occasional seeds of sedge and buttercup (Appendix C.2).
- C.9.45 A thin upper peat lens (context 10702) at 0.55m BGL produced a rather ambiguous radiocarbon date on the humic/humin fractions of 160 cal BC-cal AD 70 and cal AD 600-760 (Fig. 21; Appendix C.5). Pollen here suggests a significant increase in tree and shrub cover to 45%, notably hazel-type, but also alder and oak, with occurrences of elm, birch, willow and heather. This may suggest re-growth of hazel-type scrub and may indicate that some areas of land, perhaps previously used for pasture and/or arable activity, had been abandoned. The quantity of pollen from aquatic plants suggests locally damp conditions, with sufficient water for plants with submerged leaves to grow. Of significance also is an abundance of moss spores of *Sphagnum*, suggesting the moss was expanding at the site (Appendix C.8). Waterlogged plant remains largely comprised fine, poorly preserved seed coat fragments which appear to be from bulrushes (*Typha* sp.), as well as small fragments of stem/stalk (Appendix C.2).
- C.9.46 Subsamples for ostracods, foraminifera and diatoms were assessed from a range of deposits from OCA-WS405A, OCA-WS414A and Trench 107 (Fig. 21). Unfortunately, ostracods and foraminifera were found to be entirely absent throughout (see Whittaker, Appendix C.6 this report). In contrast, diatom assemblages were found to be abundant and diverse in the more organic sediments from the boreholes infilling the deeply incised channels, and in the lower part of the sample sequence in Trench 107 (contexts 10706 and 10705). Diatoms were present in the upper part of the sequence in Trench 107 (contexts 10704, 10703 and 10702), but preservation was poorer and the assemblages less diverse (see Hill, Appendix C.7 this report). Overall, in the better-preserved subsamples, the assemblages were of similar character, typified by the benthic species that thrive on muddy substrates and on living or decaying organic matter. In addition, some species identified are classified as aerophilous, preferring periods of submergence and emergence from water. No planktonic diatoms were encountered in any samples, suggesting that all depositional contexts were probably quite shallow. There was no indication from the diatom assemblages of brackish conditions from direct tidal influence, all diatoms

appeared to derive from freshwater contexts. The majority of the subsamples also contained chrysophyte cysts, which are predominantly freshwater and are found in specific habitats such as lakes, wet meadows, ephemeral ponds, and Sphagnum bogs. The testate amoebae *Cyclopyxis arcelloides*, encountered in three of the samples, is also most often linked to freshwater contexts and sphagnum mosses.

Transect 5 (Fig. 17)

- C.9.47 Transect 5 was positioned to provide a profile of the well-defined palaeochannel north of the main island promontory. Aligned broadly N-S, it includes Boreholes OCA-WS501-OCA-WS505 and incorporates Trenches 6 and 14, the latter notable for the discovery of an alignment of wooden stakes radiocarbon dated to the early Iron Age at 760-410 cal BC (Figs 5 and 13; Plates 3-5; Appendices B.5 and C.5). Figure 17 illustrates London Clay bedrock (Unit X) and weathered bedrock (Unit IX) at the base of the sequences. The surface of the weathered bedrock occurred at c 1m OD in Trench 6 to the north, and c 1.5m OD in OCA-WS505 to the south. Overlying the bedrock lay brickearth type deposits (Unit VI), similar to that seen elsewhere on the site, to a maximum of c 1.5m in thickness in OCA-WS501.
- C.9.48 An incised palaeochannel, corresponding to that seen on the LiDAR is clearly illustrated truncating the bedrock and brickearth with the deepest point located in OCA-WS503A at c -0.4m OD. The palaeochannel is predominantly filled with a series of fine-grained dark brownish grey organic clay silts, detrital in nature, with a peaty unit recorded at 0.86-1.2m BGL (2.27-1.93m OD). The peat was sealed by oxidised alluvium and a further intercalated thin peat lens at 0.52-0.58m BGL (2.61-2.55m OD) (Plate 22).
- C.9.49 Similar to Transect 4, the base of the palaeochannel in OCA-WS503A at 3.08-3.13m BGL was radiocarbon dated to the middle Bronze Age at 1380-1120 cal BC (Fig.21; Appendix C.5). Waterlogged plant remains from this horizon were dominated by seeds of water plantains and water crowfoot. Rushes, pondweed, and water dropwort are also well-represented. Fragmentary Insect remains and caddisfly larval cases are present together with water flea (*Daphnia*) ephippia and bryozoan statoblasts (Appendix C.2).
- C.9.50 Up-profile at 1.50-1.55m BGL the organic clay silt was dated to the early Iron Age at 790-540 cal BC. The deposit produced as similar seed assemblage to that described above. Here, the organic clay silt may be an equivalent of that recorded in Trench 14 (contexts 1416 and 1415) through which the similarly dated wooden stakes were driven through (Plate 23). The overlying peat was dated in Trench 14 to the middle to late Iron Age at 410-200 cal BC and 360-50 cal BC (see Nicholson, this report), suggesting this unit accumulated after the wooden structure was constructed. The structure is aligned broadly perpendicular to the channel, perhaps suggesting it was constructed across the watercourse. Given the very organic nature of the fills, together with the palaeo-environmental data provided here, and from similar deposits in Transect 4 (see above), it is probable the channel at this point was much silted, vegetated with sedges and rushes, shallow with a slow-moving current and backwater areas of standing water. The high level of the weathered bedrock in Section 10700 (Trench 107) at just under 1m OD would suggest the stakes at this location were driven into the bank of the channel. The weathered bedrock here appeared as a stiff blue and olive brown mottled clay exhibiting polished surfaces (slickensides).

C.9.51 Within the overlying oxidised alluvium, the thin peat lens was radiocarbon dated in Trench 107 (context 1412) to the Saxon period at cal AD 700-950 and cal AD 880-1020. It is notable that these dates are similar to that produced from the humic (soluble) fraction of a similar upper peat lens in Trench 107, Transect 4 (context 10702, Fig. 21).

Transects 12, 13 and 14 (Figs 18, 19 and 20)

C.9.52 Transects 12, 13 and 14 were generated mainly from trench profiles in order to illustrate the basal topography across the main island promontory from west to east. Transect 12 is located across the northern part of LP48, intersecting with Transects 3 and 5. It incorporates palaeochannel sequences as well as a small floodplain island where a LBA cremation deposit was excavated. Transect 13 is located across the main (northern part) part of the island promontory, incorporating the floodplain margins and a palaeochannel to the east. Transect 14 is located in the southern part of the site to illustrate the sequences along the north bank of the main palaeochannel on the south side of the island promontory.

C.9.53 Overall, the basal topography is consistent with that described above and with the LiDAR data. The incised palaeochannels illustrated in Transect 12 (Fig. 18) correspond with those in Transects 3 and 5. The fills and overlying peat and alluvial sequences are very similar to that seen elsewhere across the site north of the island promontory, with the detrital and gleyed alluvium (Units IIIc and III d) featuring prominently beneath the main peat body. The upper thin peaty lens is also apparent in a number of locations, although varying from an organic silt clay to a more humic facies. In the eastern part of the transect a rise in the surface of the underlying brickearth to c 2.7m OD (Unit VI, Trenches 4, 6 and 7) marks the location of a possible island, close to the edge of the higher ground as indicated on the LiDAR. Here a cremation deposit in Trench 6 (context 606, Plate 1) sealed beneath the oxidised alluvium was radiocarbon dated to the late Bronze Age at 1110-900 cal BC (see Appendix C.5), and is associated with a possible leached horizon (Unit V, context 604) weathered into the top of the underlying brickearth. A further small island is located in the vicinity of Trench 3 (south, Section 300).

C.9.54 Transect 13, illustrated in Figure 19, crosses the denuded interfluvium in the west (described in Transect 2, above). On the western side of the island promontory high-level gravelly Head deposits (Unit VII) were recorded in Trenches 27, 28 and 29. In Trench 28 these are recorded at c 0.55m BGL. The surface of these deposits beneath subsoil was marginally leached and weathered. To the east the basal deposits are dominated by brickearth (Unit VI), the surface reaching c 4.0m OD in Trench 44. East of Trench 45, the transect descends onto the floodplain. The alluvial and peat sequences in Trenches 37 and 38 are typical of those described elsewhere across the site. Based on the LiDAR data, the incised palaeochannel in Trench 38 (Plate 24) is correlated with that investigated in Transect 5 (Section 1400, Plate 23, Fig.17).

C.9.55 Transect 14, illustrated in Figure 20, crosses from the margins of the main palaeochannel in the south-east, across the southern end of the denuded interfluvium, and onto the higher ground along the southern side of the island promontory. As with Transect 13, high-level gravelly Head (Unit VII) is recorded on the western side of the island promontory, here beneath a thin layer of alluvium. In Trench 76 (Section 7601), the surface of the Head (context 7602) occurred at 0.48m BGL (3.24m OD) where it exhibited heavy weathering with iron mineralisation (Plate 25). Overlying the Head

was a thin grey horizon (context 7606) interpreted as a possible buried soil, sealed by a thin layer of oxidised alluvium (context 7601). Further east, Transect 14 skirts the edge of the main palaeochannel on the south side of the island promontory, intersecting with Transect 4 (Trenches 79, 91, 93, Borehole OCA-WS402, Trenches 90, 86, 95, 96 and 72). Here, the low-level sand and gravel (Unit VII), overlying weathered bedrock and sealed beneath the brickearth (Unit VI), is well-represented, occurring at c 1m to 2m OD. In Trench 91 the sand was coarse-grained, slightly clayey and strong reddish brown with iron mineralisation. The overlying brickearth was thinly bedded horizontally, with a minor clast component and gravel stringers. The upper surface of the brickearth was notably leached/weathered (Plate 26). As with Transect 13, brickearth appears to dominate much of the sequences towards the east in Transect 14, capped by relatively thin deposits of oxidised alluvium.

Discussion

- C.9.56 Overall, for the purpose of this evaluation, the extensive geoarchaeological investigations undertaken throughout Land Parcels (LPs) 47 and 48f-h, supported by detailed analysis of LiDAR data, radiocarbon dating and palaeo-environmental assessment, have served well in broadly characterising the nature and potential of the sub-surface sedimentary sequences underlying the site. In summary the following observations can be made, supported by a series of composite transects (Transects 2-5 and 12-14, Figures 14-21).
- C.9.57 The site is located predominantly on a wide low-lying floodplain or basin (at c 3m OD) in the middle reaches of the Mar Dyke tributary, c 9.5km upstream of the Thames confluence and east of the current Mar Dyke channel (a man-made canalised diversion). The BGS maps the bedrock geology as London Clay, overlain by Pleistocene 'Head' deposits which mantle the surrounding slopes and outcrop as low islands within the floodplain, surrounded by alluvium of probable Holocene age. Detailed analysis of LiDAR data and geotechnical interventions prior to the evaluation commencing suggested the presence of a large island (c 400m across) of slightly raised ground (maximum of c 4.5m OD) in the centre of the site mantled by 'Head' and circled by a series of clearly-defined meandering palaeochannels to the south, east and north. West of the island, a less well-defined N-S dip between the main island and adjacent higher ground west of the modern Mar Dyke canal indicated this area to be a denuded interfluvium, although it was not clear whether a deep palaeochannel were present in this area at depth. Two smaller floodplain islands were also detected on the LiDAR in the north-eastern area of the site adjacent to higher ground of the valley slopes.
- C.9.58 In addition to the evaluation trenches, which were excavated to a 2m BGL in the alluvial zones (with machine-dug test pits at selected locations extending the depth to 3m), an extensive series of boreholes (windowless samples) were drilled to extract intact cores from the deeper sequences, anticipated to reach depths of up to 4m below ground level (BGL). All of the boreholes were successfully drilled to deposits interpreted as weathered London Clay Bedrock, enabling composite profiles of the full sedimentary sequence to be generated across the site, illustrated as a series of transects.
- C.9.59 The basal topography revealed by the transects closely mirrors that indicated from the initial LiDAR analysis. The central part of the large floodplain island appears to be underlain by London Clay bedrock, the upper parts of which are weathered orange

brown and are capped by an orangey brown silt clay brickearth-type deposit that thickens to the north, east and south. The lower interface of the weathered London Clay and brickearth was not always easy to detect in the absence of the basal gravelly facies (see below) due to their similarity in appearance. The generally clayey nature of most of the facies recorded on the site and the rarity of coarse-grained facies is likely to be a reflection of the composition of the underlying bedrock from which the sediment derives locally. Where sand and gravel deposits were recorded, these are almost exclusively associated with higher energy fluvio-glacial outwash and slope deposits (solifluction), probably dating to the late Devensian, transporting material from a wider catchment (including older terrace gravels capping the higher ground).

- C.9.60 At the base of the deeper brickearth on the south side of the island (Transects 4 and 14) lie thin deposits of sand and gravel of possible late Devensian fluvial origin. To the north (Transect 3), deeply buried deposits in a similar stratigraphic position appear as clayey gravels more akin to Head. Higher level gravelly deposits were also detected on the western side of the island associated with the denuded interfluvium. The interfluvium, investigated in Transect 2, does not appear to be associated with deep palaeochannel deposits – here, the weathered London Clay appeared to lie at relatively shallow depths (Transects 2, 13 and 14) and it may represent a late Devensian overflow to the main channel during periods of high discharge.
- C.9.61 It is not wholly clear if the brickearth was originally deposited as late Devensian slope deposits (Head) emanating from the higher ground and/or through alluvial deposition. Although the deposit frequently appeared homogenous, at depth there was some indication of localised bedding with increasing sand and gravel content (gravel stringers). Occasionally slightly darker grey lenses hint at potential buried surfaces suggesting greater structural complexity than is presented in the transects. It is possible that the upper levels of the brickearth date to the earlier part of the Holocene, representing a fining up sequence. A rare organic lens within the brickearth in OCA-WS307 (Transect 3) has been radiocarbon dated to the late Glacial or early Holocene period (Figs 15 and 21, see also Nicholson, Appendix C.5). Samples from this submitted for palaeo-environmental assessment (pollen, diatoms and waterlogged plant remains) suggested poor preservation and limited potential.
- C.9.62 In a number of trenches on the island, *in situ* flint scatters were recorded within the very upper levels of the brickearth, although in Trench 86 late Mesolithic worked flint extending to c 1m BGL and early Neolithic pottery in the upper levels may be preserved within a shallow subsoil hollow. A weathered (E-leached) horizon was frequently found at the top of the brickearth and high-level gravelly Head which may represent the remnants of a buried landsurface. A cremation deposit dated to the late Bronze Age was also found associated with the leached horizon on a smaller island in the north-eastern part of the site, sealed by alluvium (Transects 5 and 12, Trench 6).
- C.9.63 Investigation of the Holocene floodplain and palaeochannel zones marginal to the main island was mainly carried out through N-S borehole Transects 3-5 to the north and south, although E-W transects 12-14 also provide additional detail from trench profiles. In general, the larger palaeochannels identified appear to have been incised to depths of c 2.5-3.5m BGL. In Transect 4, the wider channel to the south of the island promontory exhibited some complexity with two deeper incisions either side of a bedrock high in the centre, perhaps representing an old meander bend cutting into

the southern edge of the island. Radiocarbon dating of the basal deposits at three locations in Transects 4 and 5 produced similar dates of the early to middle Bronze Age (Fig. 21, Appendix C.5). No palaeochannel deposits of Mesolithic or Neolithic date were identified. It is possible that earlier deposits have been eroded/reworked, given the meandering form of the palaeochannels visible on the LiDAR, although locally it is also possible that such deposits may be preserved in other areas of site as fragmentary records.

- C.9.64 The deposits infilling the identified palaeochannels and extending across the floodplain varied from gleyed and detrital alluvium to organic clay silts and more humic peaty deposits. The upper part of the sequence consisted of typical oxidized orange brown silty clay alluvium. Overall, although individual sequences appeared complex with various interdigitating facies (see defined facies types in the Results section above), the broad pattern appeared remarkably consistent across the site. For the most part radiocarbon dates suggest that deposition of a large part of the alluvial sedimentary stack occurred during the later prehistoric period, from the early Bronze Age (the base of the southern channel in Transect 4) into the late Iron Age. At least three peaty organic horizons were detected that could be correlated across numerous interventions. The earliest was located in the large palaeochannel south of the island promontory in Transect 4, radiocarbon dated to the late Bronze Age. A further horizon up-profile was identified in a large number of floodplain profiles and was dated in Transects 4 and 5 to the early and middle to late Iron Age. A thin upper peaty lens intercalated within the upper oxidised alluvium produced an ambiguous radiocarbon date on the humin/humin fractions in Transect 4 (Trench 107) of either middle to late Iron Age or Saxon. However, a clear Saxon radiocarbon date (c cal AD 700-1020) was forthcoming from a stratigraphically similar deposit in Transect 5 (Trench 14).
- C.9.65 Assessment of a range of palaeo-environmental proxies (pollen, waterlogged plant remains and diatoms) indicates preservation of assemblages to be generally very good within the palaeochannel deposits, although less so within the upper 1m of the sediment stack associated with the two upper peat deposits and oxidised alluvium. The pollen demonstrated clear developmental change within the regional catchment suggesting a gradual reduction in arboreal cover from 67% in the early Bronze Age to as little as 12% by the early Iron Age which may be related to woodland clearance for pastoral and arable agriculture. This coincides with the occurrence of possible pollen of cereals - barley and wheat/oats. Locally, the pollen and waterlogged seed assemblages suggest freshwater aquatic environments with species typical of marshy areas, in slow moving or standing water or on the banks of rivers and streams - bulrush was commonly recorded along with pondweed, water crowfoot, water plantain, water-dropwort, and spike rushes. Fragmentary insect remains were common as well as caddisfly larval cases and waterfleas. It is probable that by the early Iron Age (coinciding with the construction of the timber stake alignment in Trench 14) the channel system was much silted, vegetated with sedges and rushes, and shallow with a slow-moving current and backwater areas of standing water. There is some indication from the pollen assemblages of a gradual transition to a sedge-fen environment within the upper parts of the palaeochannels during this period.
- C.9.66 No ostracod or foraminifera were preserved within the samples. However, diatom assemblages were found to be abundant and diverse. The assemblages were

generally of similar character, typified by the benthic species that thrive on muddy substrates and on living or decaying organic matter. In addition, some species identified are classified as aerophilous, preferring periods of submergence and emergence from water. No planktonic diatoms were encountered in any samples, suggesting that all depositional contexts were probably quite shallow. There was no indication from the diatom assemblages of brackish conditions from direct tidal influence, all diatoms appeared to derive from freshwater contexts. The majority of the samples also contained chrysophyte cysts, which are predominantly freshwater and are found in specific habitats such as lakes, wet meadows, ephemeral ponds, and Sphagnum bogs. The testate amoebae *Cyclopyxis arcelloides*, encountered in three of the samples, is also most often linked to freshwater contexts and sphagnum mosses.

- C.9.67 Although no direct tidal influence was detected in the sequences, the development of sedge-fen environments during the Iron Age, as detected in the pollen assemblages, may be related to the backing up of freshwater systems as a consequence of a migrating tidal head further downstream - it is during this period that major marine incursion was occurring on the Thames floodplain. However, it is also very likely channel silting, flooding and overbank alluviation occurred as a result of an increase in sediment load from run-off as a result of woodland clearance and agricultural intensification within the catchment during the later prehistoric period.

Conclusions and recommendations

- C.9.68 In conclusion, the waterlogged Holocene floodplain and channel sequences investigated during the evaluation have high potential for more detailed geoarchaeological and palaeo-environmental study in terms of landscape reconstruction and palaeohydrology coupled with a robust programme of radiocarbon dating. This appears particularly so for the later prehistoric period from the early Bronze Age onwards. The evaluation indicated limited preservation of sediment sequences from the early to middle Holocene (Mesolithic and Neolithic), although it is possible that fragmentary sequences are preserved elsewhere on the site that have not yet been exposed.
- C.9.69 Some problems were encountered related to the radiocarbon dating of the humic and humin fractions of the organic sediments due to taphonomic issues of reworking in channel situations. For this reason, future radiocarbon dating should prioritise macroscopic plant remains where possible (see Nicholson, Appendix C.5 this report).
- C.9.70 It is recommended that a small selection of cores and monoliths from key sequences (along with some OSL samples) are retained until the post excavation stage has been completed in the event that they are required for full analysis. Selection of samples for retention should be carried out in consultation with the LTC Palaeolithic and geoarchaeological specialists following a review of this report, in case OSL dating is required from the Pleistocene sequences to further clarify the age of the basal brickearth and Head deposits related to the earlier (Pleistocene) development of the Mar Dyke basin.

Appendix D References

ACBMG, 2007 Ceramic building material, minimum standards for recovery, curation, analysis and publication

Allison, R, 1966 *The changing landscape of south-west Essex from 1600 to 1850*, London, unpublished PhD thesis

Allen, T, forthcoming *Eton Rowing Lake*

Allen, T, Barclay, A, Cromarty, A M, Anderson-Whymark, H, Parker, A and Robinson, M, 2013. *Opening the wood, making the land. The Archaeology of a Middle Thames Landscape: the Eton College Rowing Course Project and the Maidenhead, Windsor and Eton Flood Alleviation Scheme. Volume 1: Mesolithic, Neolithic and Early Bronze Age*. Oxford: Oxford University School of Archaeology.

Andersen, S T, 1979 Identification of wild grasses and cereal pollen, *Danm Geol Unders* 1978, 69-92

Ballin, T B, 2021 *Classification of Lithic Artefacts from the British Late Glacial and Holocene Periods*. Oxford, Archaeopress.

Bamford, H, 1985 *Briar Hill: excavation 1974-1978*, Northampton: Northampton Development Corporation Archaeological monograph **3**

Barrett, J C, 1988 Pottery, in D Bond, Excavation at the North Ring, Mucking, Essex, *East Anglian Archaeology* **43**, 25-37

Bates, M and Stafford, E, 2013 *Thames Holocene: A Geoarchaeological Approach to the Investigation of the River Floodplain for High Speed 1, 1994-2003*, Oxford Wessex Archaeology Monograph

Berglund, B E and Ralska-Jasiewiczowa, M, 1986 Pollen analysis and pollen diagrams, In B E Berglund (ed) *Handbook of Holocene Palaeoecology and Palaeohydrology*, Wiley, 455-484

BGS, 2020 *Geology of Britain Viewer*. Retrieved from

Bishop, B, 2008 A Microlithic Industry from Woodbridge Road, Guildford, Surrey *Archaeological Collections* **94**, 125-157

Bronk Ramsey, C, 2009 Bayesian analysis of radiocarbon dates, *Radiocarbon* **51(1)**, 337-360

Brooks, D and Thomas, K W, 1967 The distribution of pollen grains on microscope slides. The non-randomness of the distribution, *Pollen et Spores* **9**, 621-629

Brück, J, 2017 Reanimating the dead: The circulation of human bone in the British Later Bronze Age, in J Bradbury, and C Scarre (eds.), *Engaging with the dead:*

Exploring changing human beliefs about death, mortality and the human body, Oxbow Books, 138-148

Brudenell, M, 2016a Late Bronze Age Pottery, in C Evans, G Appleby and S Lucy, with J Appleby and M Brudenell *Lives in the Land. Mucking Excavations by Margaret and Tom Jones, 1965-1978: Prehistoric, Context and Summary*, Oxbow Books, 158-88

Brudenell, M, 2016b Middle Iron Age Pottery, in C Evans, G Appleby and S Lucy, with J Appleby and M Brudenell *Lives in the Land. Mucking Excavations by Margaret and Tom Jones, 1965-1978: Prehistoric, Context and Summary*, Oxbow Books, 365-93

Butler, C, 2005 *Prehistoric Flintwork*, Tempus, Stroud

Cappers, R T J, Bekker R M and Jans, J E A, 2012 *Digital Seed Atlas of the Netherlands*, Groningen Archaeological Studies **4**, 2nd Edition, Barkhuis Publishing, Eelde, The Netherlands

Champion, T, 2014 Food, Technology and Culture in the Late Bronze Age of Southern Britain: Perforated Clay Plates of the Lower Thames Valley, *Proc. Prehist. Soc.* **80**, 2014, 279-98

Champness, C, Donnelly, M, Ford, B M and Haggart, A, 2015 'Life at the floodplain edge: Terminal Upper Palaeolithic and Mesolithic flint scatters and early prehistoric archaeology along the Beam River Valley Dagenham', *Essex Archaeol. Hist.* **6**, 5-45

Champness, C, Donnelly, M, Davies, A and Boothroyd, J, 2019 Bexhill to Hastings Link Road: Post-Excavation Assessment and Updated Project Design, Oxford Archaeology

Chartered Institute for Archaeologists (CIfA), 2014a *Standard and Guidance for Archaeological Evaluation*, Retrieved from

[REDACTED]

Chartered Institute for Archaeologists (CIfA), 2014b *Standard and Guidance for the Creation, Compilation, Transfer and Deposition of Archaeological Archives*

Clark, J G D and Rankine, W F, 1939 Excavations at Farnham, Surrey (1937–38): The Horsham Culture and the Question of Mesolithic Dwellings, *Proc Prehist Soc* **5**, 1-32

Cotswold Archaeology, 2022 Bulphan Fen, Bulphan, Essex Archaeological Evaluation, CA Report: SU0327_1, unpublished report prepared for Enso Energy

Denys, L, 1991-92 *A check-list of the diatoms in the Holocene deposits of the western Belgian coastal plain with a survey of their apparent ecological requirements: I. Introduction, ecological code and complete list*, Service Geologique de Belgique, professional paper **246**

- Denys, L, 1994 Diatom assemblages along a former intertidal gradient: a palaeoecological study of a subboreal clay layer (western coastal plain, Belgium). *Netherlands Journal of Aquatic Ecology* **28**, **1**, 85-96
- Devoy, R J N, 1979 Flandrian sea level changes and vegetational history of the lower Thames estuary, *Philosophical Transactions of the Royal Society of London. B, Biological Sciences*, **285**, 355-407
- Ellaby, R, 1987 The Upper Palaeolithic and Mesolithic in Surrey, in Bird, D and Bird, J (eds.), *The archaeology of Sussex to 1540*, Guildford: Surrey Archaeological Society, 54-69.
- English Heritage, 2010 *Waterlogged Wood: Guidelines on the Recording, Sampling, Conservation and Curation of Waterlogged Wood*
- Faegri, K, and Iversen, J, 1989 *Textbook of Pollen Analysis*, 4th Ed Wiley
- Field, N and Parker-Pearson, M, 2003 *Fiskerton – An Iron Age Timber Causeway with Iron Age and Roman Votive Offerings*, Oxford
- Ford, S, Bradley, R, Hawkes, J and Fisher, P, 1984 Flint-working in the metal age, *Oxford Journal of Archaeology* **3(2)**, 158-173
- Froom, R, 1976 *Wawcott III, a Stratified Mesolithic Succession*, Oxford: British Archaeological Reports (British Series) **27**
- Froom, R, 2012 *The Mesolithic of the Kennet Valley*, Roy Froom
- Goodburn, D and Davis, S, 2010 Two new tide mill finds of the 690's and 1190's and a brief update on archaeological evidence for medieval tidal levels, in J, Galloway ed *Tide and Floods*, Centre for Metropolitan History, Working Paper No **4**
- Healy, F, 1988 *The Anglo-Saxon Cemetery at Spong Hill, North Elmham. Part VI: Occupation in the seventh to second millennia BC*. East Anglian Archaeology **39**
- Hendy, N I, 1964 *An introductory account of the smaller algae of the British coastal waters. Part V: Bacillariophyceae (Diatoms)*, Fisheries Investigation Series, **I**, H.M.S.O., London.
- Highways England, 2018 *Lower Thames Crossing: A Scheme Wide Specification for Archaeological Trial Trenching: unpublished document HE540039-CJV-GEN-GEN-SPE-HER-00001draft, Revision 1.05*
- Historic England, 2010 *Waterlogged Wood, Guidelines on the recording, sampling, conservation and curation of waterlogged wood*
- Historic England, 2011 *Environmental Archaeology. A guide to the theory and practice of methods, from sampling and recovery to post-excavation*, 2nd edition, Centre for Archaeology guidelines
- Historic England, 2015a *Management of Research Projects in the Historic Environment: The MoRPHE Project Managers' Guide*, Swindon: Centre for Archaeology Guidelines

Historic England, 2015b *Geoarchaeology: Using an earth sciences approach to understand the archaeological record*

Jacobi, R M, 1975 *Aspects of the post-glacial archaeology of England and Wales*, Unpublished PhD thesis: University of Cambridge

Jacobi, R M, 1978 The Mesolithic of Sussex, in P.L. Drewett (ed.) *Archaeology in Sussex to AD 1500*, Council for British Archaeology Research Report **29**, 15-22

Jacobi R M, 1980 The Mesolithic of Essex, in Buckley, D G (ed.) *Archaeology in Essex to AD 1500*, Council for British Archaeology Research Report **34**, 14-25

Jacobi, R M, 1996 The Late Upper Palaeolithic and Mesolithic in Essex, in O Bedwin (ed.) *The Archaeology of Essex; Proceedings of the Writtle Conference*, Chelmsford: Essex County Council, 10-14

Jacomet, S, 2006 *Identification of cereal remains from archaeological sites*, Basel University, Basel

Jacques, D, Lyons, T and Phillips, T, 2018 *Blick Mead: Exploring the 'first Place' in the Stonehenge Landscape*, Peter Lang

Jones, A P, Tucker, M E and Hart, J K, 1999 Guidelines and Recommendations, in *The description and analysis of Quaternary stratigraphic field sections*, Technical Guide No. **7**. (eds A P Jones, M E Tucker and J K Hart), Quaternary Research Association: London, 27-76

Jones, P, 2013 *A Mesolithic 'Persistent Place' at North Park Farm, Betchingley, Surrey*, Woking: Spoilheap Publications, Monograph **10**

Kinnes, I and Birley, 2016 Earlier Neolithic Pottery, in C Evans, G Appleby and S Lucy, with J Appleby and M Brudenell *Lives in the Land. Mucking Excavations by Margret and Tom Jones, 1965-1978: Prehistoric, Context and Summary*, Oxbow Books, 69-70

Krammer, K and Lange-Bertalot, H, 1986-1991 *Subwasserflora von Mitteleuropa. Bacillariophyceae: 2 (1) Naviculaceae; 2 (2) Bacillariaceae, Epithemiaceae, Surirellaceae; 2 (3) Centrales, Fragilariaceae, Eunotiaceae; 2 (4) Achnantheaceae*, Fischer, Stuttgart

Lavender, N, 1998 Prehistoric and Romano-British Activity at the William Edwards School, Stifford Clay Road, Grays; excavations 1997, *Essex Archaeology and History* **29**, 19-32

Leivers, M, Barnett, C and Harding, P, 2007 'Excavation of Mesolithic and Neolithic flint scatters and accompanying environmental sequences at Tank Hill Road, Purfleet, 2002', *Essex Archaeol. Hist.* **38**, 1-44

Mann, D G, Round, F E and Crawford, R M, 2007 *The Diatoms: Biology and Morphology of the Genera*, 2nd edn, Cambridge

Marples, N, 2013 Flint Report [and] The Flint Assemblage, in Jones, P. *A Mesolithic 'Persistent Place' at North Park Farm, Bletchingley, Surrey*, Woking: Spoilheap Publications, Monograph **10**, 30-79; 109-114

McKinley, J I, 1994 Bone fragment size in British cremation burials and its implications for pyre technology and ritual, *Journal of Archaeological Science* **21 (3)**, 339-342

McKinley, J I, 2000 'The analysis of cremated bone', in Cox, M and Mays, S, (eds) 2000 *Human Osteology in Archaeology and Forensic Science*, London, Greenwich Medical Media

McKinley, J I, 2004 Compiling a skeletal inventory: cremated human bone, in M Brickley and J I McKinley (eds) 2004, *Guidelines to the Standards for Recording Human Remains*, IFA Paper No. **7**, British Association for Biological Anthropology and Osteoarcheology and the Institute of Field Archaeologists, 9-13

McKinley, J I, 2013 Cremation: excavation and analysis, in S Tarlow and L Nilsson Stutz (eds) *The Oxford Handbook of the Archaeology of Death and Burial*, Oxford, Oxford University Press, 147-72

Medlycott, M (ed.), 2011 *Research and Archaeology Revisited: A Revised Framework for the East of England*, East Anglian Archaeology Occasional Paper **24**: Association of Local Government Archaeological Officers.

Mithen, S, Marshall, G, Dopel, B and Lane, M, 2000 The Experimental Knapping of Flint Beach Pebbles, in Mithen, S (ed.) *Hunter-gatherer landscape archaeology: The Southern Hebrides Mesolithic Project 1988-98. Volume 2: Archaeological Fieldwork on Colonsay, computer modelling, experimental archaeology and final interpretations*, Cambridge: McDonald Institute for Archaeological Research Monographs, 529-539

Moore, P D, Webb J A and Collinson, M E, 1991 *Pollen analysis*, 2nd edn Oxford

Oxford Archaeology, 2020a Lower Thames Crossing Scheme-wide Written Scheme of Investigation for Trial Trenching south of the River Thames

Oxford Archaeology, 2020b Lower Thames Crossing Scheme-wide Written Scheme of Investigation for Trial Trenching north of the River Thames

Oxford Archaeology, 2021 Lower Thames Crossing: Detailed Written Scheme of Investigation P for Trial Trenching of Land Parcels 43, 45-48, 120-125

Oxford Cotswold Archaeology, 2020a Lower Thames Crossing Archaeological Evaluation Report for Trial Trenching of Land Parcel 21, Whitfield, North of Stifford Clays Road, Baker Street, Essex, Document Number: HE540039-BAL-GEN-GEN-REP-HER-00027, Oxford: Oxford Cotswold Archaeology

Oxford Cotswold Archaeology, 2020b Lower Thames Crossing Archaeological Evaluation Report for Trial Trenching of Land Parcel 22, Whitfield South Scheduled Monument Cropmark Complex, South of Stifford Clays Road, Baker Street, Essex,

Document Number: HE540039-BAL-GEN-GEN-REP-HER-00026, Oxford: Oxford Cotswold Archaeology

Oxford Cotswold Archaeology, 2021 Lower Thames Crossing Archaeological Evaluation Report for Trial Trenching of Land Parcels 48B and 48C, Mar Dyke Valley, between South Ockendon and Orsett, Essex, Document Number: HE540039-BAL-GEN-GEN-REP-HER-00041, Oxford: Oxford Cotswold Archaeology

Oxford Cotswold Archaeology, 2022a Lower Thames Crossing Archaeological Evaluation Report for Trial Trenching of Land Parcels 43, 45A-E and 46, Mar Dyke Valley, between South Ockendon and Orsett, Essex, Document Number: HE540039-BAL-GEN-GEN-REP-HER-00062 Oxford: Oxford Cotswold Archaeology

Oxford Cotswold Archaeology, 2022b Lower Thames Crossing Archaeological Evaluation Report for Trial Trenching of Land Parcels 6-8, Land West of Linford, East Tilbury, Essex, Document Number: HE540039-BAL-GEN-GEN-REP-HER-00042, Oxford: Oxford Cotswold Archaeology

Palmer, J J, 2019 *Open Domesday*, [REDACTED] University of Hull

Pietrzak, B and Slusarczyk, M, 2006 The fate of ehippia – Daphnia dispersal in time and space, *Polish Journal of Ecology* **54**(4), 709-714

Pitts, M W and Jacobi, R M, 1979 Some Aspects of Change in Flakes Stone Industries of the Mesolithic and Neolithic in Southern Britain, *Journal of Archaeological Science* **6**, 163–177

Place Services, 2019 *Lower Thames Crossing Aerial Investigation and Mapping Report*, Essex County Council

Pryor, F, 2002 *Archaeology and Environment of the Flag Fen Basin*, London: English Heritage archaeological reports.

Rankine, W F, 1952 A Mesolithic chipping floor at the Warren, Oakhanger, Selborne, Hampshire, *Proceedings of the Prehistoric Society* **18**, 21-35

Reimer, P, Austin, W, Bard, E, Bayliss, A, Blackwell, P, Bronk Ramsey, C, Butzin, M, Cheng, H, Edwards, R, Friedrich, M, Grootes, P, Guilderson, T, Hajdas, I, Heaton, T, Hogg, A, Hughen, K, Kromer, B, Manning, S, Muscheler, R, Palmer, J, Pearson, C, van der Plicht, J, Reimer, R, Richards, D, Scott, E, Southon, J, Turney, C, Wacker, L, Adolphi, F, Büntgen, U, Capano, M, Fahrni, S, Fogtmann-Schulz, A, Friedrich, R, Köhler, P, Kudsk, S, Miyake, F, Olsen, J, Reinig, F, Sakamoto, M, Sookdeo, A, and Talamo, S, 2020 The IntCal20 Northern Hemisphere radiocarbon age calibration curve (0–55 cal kBP), *Radiocarbon*, **62**

Reynier, M, 1994 A stylistic analysis of ten Early Mesolithic assemblages in south east England In N Ashton and A David (eds.) *Stories in Stone*. Lithic Studies Society Occasional Paper 4. London, 199-205.

Reynier, M J, 2005 *Early Mesolithic Britain: Origins, development and directions*. British Archaeological Reports (British Series) No. **393**

- Ruppert, E E, Fox, R S and Barnes, R D, 2004 Lophoporata, *Invertebrate Zoology*, 7th edition, Brooks/Cole, 829-845
- Saville, A, 1981 *Grimes Graves, Norfolk: Excavations 1971-72. Vol.2. The Flint Assemblage*, London: HMSO
- Schweingruber, F H, 1990 *Microscopic Wood Anatomy; Structural variability of stems and twigs in recent and subfossil woods from Central Europe*, 3rd edition, Birmensdorf, Eidgenössische Forschungsanstalt WSL.
- Stace, C, 2010 *New flora of the British Isles*, Cambridge University Press
- Stafford, E, Goodburn, D and Bates, M, 2012 *Landscape and prehistory of the east London wetlands; Investigations along the A13 DBFO, Road Scheme, Tower Hamlets, Newham and Barking and Dagenham*, Oxford Archaeology Monograph No **17**
- Stuiver, M and Polach, H A, 1977 Reporting of ¹⁴C data, *Radiocarbon* **19**, 355–363
- Taylor, M, with Mitchell, N and Thomas, G, forthcoming The Worked Wood, in Allen, T G, Bradley, P, Cromarty, A-M and Parker, A, *Bridging the river, dividing the land: the archaeology of a Middle Thames Landscape. Volume 2: from the middle Bronze Age to the Roman period*, Oxford Archaeology Thames Valley Landscapes Monograph
- Van Dam, H, Mertens, A and Seinkeldam, J, 1994 A coded checklist and ecological indicator values of freshwater diatoms from the Netherlands, *Netherlands Journal of Aquatic Ecology*, **28**, (1), 117-133
- van Der Werff and Huls, 1958-1974 *Diatomeeënflora van Nederland*, Eight parts, published privately by van der Werff, De Hoef (U), The Netherlands
- van Geel, B, 1978 A palaeoecological study of Holocene peat bog sections in Germany and the Netherlands based on the analysis of pollen, spores and macro- and microscopic remains of fungi, algae, cormophytes and animals, *Review of Palaeobotany and Palynology*, **25**, 1-120
- Vos, P C and de Wolf, H, 1988 Methodological aspects of palaeo-ecological diatom research in coastal areas of the Netherlands, *Geologie en Mijnbouw*, **67**, 31-40
- Vos, P C and de Wolf, H, 1993 Diatoms as a tool for reconstructing sedimentary environments in coastal wetlands: methodological aspects, *Hydrobiologia*, **269/270**, 285-96
- Wenban-Smith, F and Bates, M, 2020 *Lower Thames Crossing, Palaeolithic and Quaternary Deposit Model (PQDM), and Preliminary Assessment of Archaeological Potential*.
- Wilkinson, T, 1988 *Archaeology and environment in South Essex: Rescue archaeology along the Grays by-pass 1979-80*, East Anglian Archaeol Rep **42**

Appendix E Abbreviations and Glossary

ADS Archaeology Data Service. Digital archaeological archive

CDM Construction Design Manual. Health and safety guidance for the construction industry

CPD Continuing Professional Development

ClfA Chartered Institute for Archaeologists

DBA Desk Based Assessment. Detailed assessment of archaeology and other aspects of the historic environment

DCO Development Consent Order

EIA Environmental Impact Assessment. Detailed study of environmental impacts as directed under the The Town and Country Planning (Environmental Impact Assessment) Regulations 2017 following on from EU Directive EIA Directive (85/337/EEC)

ES Environmental Statement. The principal environmental report detailing environmental impacts within an EIA

GPS Global Positioning System

HER Historic Environment Record

LTC Lower Thames Crossing

MCIfA Member of the Chartered Institute for Archaeologists

MoRPHE Management of Research Projects in the Historic Environment

NMP National Mapping Programme. A study of aerial photographs and digitisation of resulting data into GIS. Originally funded by Historic England

OASIS Online Access to the Index of archaeological investigations.
The OASIS project brings together a number of strategic partners: the Archaeology Data Service, Historic England, Historic Environment Scotland, and the Royal Commission on the Ancient and Historical Monuments of Wales under the umbrella of the University of York

OCN Old County Number. Historic England's reference for material that is not readily-available online and may represent historic archaeological work that consists of paper archives or has yet to be formally reported on

PINS Planning Inspectorate

RAMS Risk Assessment Method Statement

SMC Scheduled monument consent

TDR Trusted Digital Repository

UKIC United Kingdom Institute for Conservation

WSI Written Project of Investigation. A detailed method statement for archaeological work

WSL – Western Southern Link
The Western Southern Link (WSL) is an alternative for Short List Routes 2, 3 and 4 to the south of the River Thames.

Appendix F Site Summary

Site name:	Lower Thames Crossing Land Parcels 47 and 48f-h, Mar Dyke Valley between South Ockendon and Orsett, Essex
Site code:	LTC43M21
Grid Reference	NGR TQ 62012 83241
Type:	Evaluation
Date and duration:	13th August to 5th November 2021, 12 weeks
Area of Site	32.68ha

Location of the archive:

The archive from LTC43M centre (Land Parcels 47 and 48f-h) will form part of the overall trial trenching scheme archive. This will be deposited in a repository consistent with the standards required by the Museums and Galleries Commission following completion of the archaeological phase of this project. This may either be with the local receiving museum in Thurrock or, if no such repositories are available, with a repository for the whole project designated by LTC. LTC retain the overall responsibility for the successful deposition of the project archive.

Currently, the archive is held at Oxford Archaeology's head office, Janus House, Osney Mead, Oxford, Oxfordshire, OX2 0ES. Oxford Archaeology will store the archive for LTC for a maximum period of 2 years following the completion of the project. If the storage of the archive at OA's office extends past this period, an extension to the storage period and final deposition timetable will be reviewed by OA and LTC and agreed with the major stakeholders.

Summary of Results:

Oxford Cotswold Archaeology was commissioned by Balfour Beatty to undertake a trial trench evaluation of land parcels 47 and 48f-h covered by WSI P of the Lower Thames Crossing Pre-Enabling Works. These land parcels are located in the Mar Dyke valley between South Ockendon and Orsett within the county of Essex and Thurrock unitary authority (NGR TQ 62012 83241). A total of 123 trenches were dug and recorded between 13th August and 5th November 2021.

The investigations revealed a series of palaeochannels meandering on an E-W alignment across the northern section of the investigation area, then looping around the eastern edge and returning along the southern edge of the site. These palaeochannels contained alluvial sequences in excess of 3m deep providing good conditions for the preservation of waterlogged plant and insect remains and pollen. The centre of the site, around which the palaeochannels had formed was a slightly raised promontory of head deposits, at a height of 4-4.5m aOD. To the west of this elevated area the topography sloped down to a height of approximately 3.1m aOD

but no palaeochannels and only a thin layer of alluvium were seen on this side of the site.

On the southern edge of the raised promontory a dense scatter of 1254 worked flints, with diagnostic material of late Mesolithic date, was found, concentrated in Trench 86 and extending south into Trench 90. The assemblage included microburins, microliths and a tranchet axe/adze sharpening flake. A small quantity of early Neolithic pottery, representing at least six different vessels were also recovered from the top of the flint scatter in Trench 86, and some of the upper flints may also be of this date.

The remains of other flint scatters were recorded on the north and east edges of the promontory and floodplain in Trenches 20 and 72 respectively, and smaller groups of flint in most of the trenches along the north edge. Whilst these included a high proportion of blades suggesting later Mesolithic or early Neolithic technologies, some were also mixed with later prehistoric material.

Assessment of the borehole and trench transects identified two palaeochannel cuts on both the north and south sides of the promontory. The channel crossing Trench 14 on the north was radiocarbon-dated to the middle Bronze Age, while those on the south were dated to the early and middle Bronze Age. The character of the sediments filling both sets of channels and the wider floodplain thereafter, and the environmental evidence from the organic sediments and peats, was similar, and indicated a gradual silting of the channel system, becoming slow-flowing by the early Iron Age. Environmental evidence demonstrate increased clearance through to the middle Iron Age, with grazing throughout and possibly some arable agriculture in the late Bronze Age and Iron Age. No evidence of marine transgression this far up the Mar Dyke river was found.

Few archaeological cut features were encountered. Two unurned cremations were found, in Trenches 6 and 90, and although without accompanying artefacts, charcoal from the cremation in Trench 6 was radiocarbon dated to the late Bronze Age. A scatter of pits, some containing charcoal, was also found, but no dating evidence. Later prehistoric sherds of pottery were recovered in small quantities from alluvial deposits or the surface of the natural in Trenches 22, 60, 69, 90 and 97 and part of a late Bronze Age, fired clay perforated plate from Trench 44.

In Trench 14 in the north-east part of the site a row of six waterlogged timber piles was found set within alluvial silt and traversing an east-west aligned palaeochannel. One of the timbers has been radiocarbon dated to the early Iron Age. The full extent of the structure is unknown at this stage but may have formed a footbridge across the channel.

Roman, Saxon/early medieval and medieval evidence is absent, although a widespread deposit of peat overlying the channels and thought to represent a phase of the Mar Dyke fen was dated to the mid-late Saxon period. No early post-medieval activity nor any drainage ditches were evident either, and historic maps provide the first evidence for partial drainage of the fen after the canalisation of the Mar Dyke, probably in the 18th century, but as the maps make clear, the majority of the site remains fen throughout the 19th century.

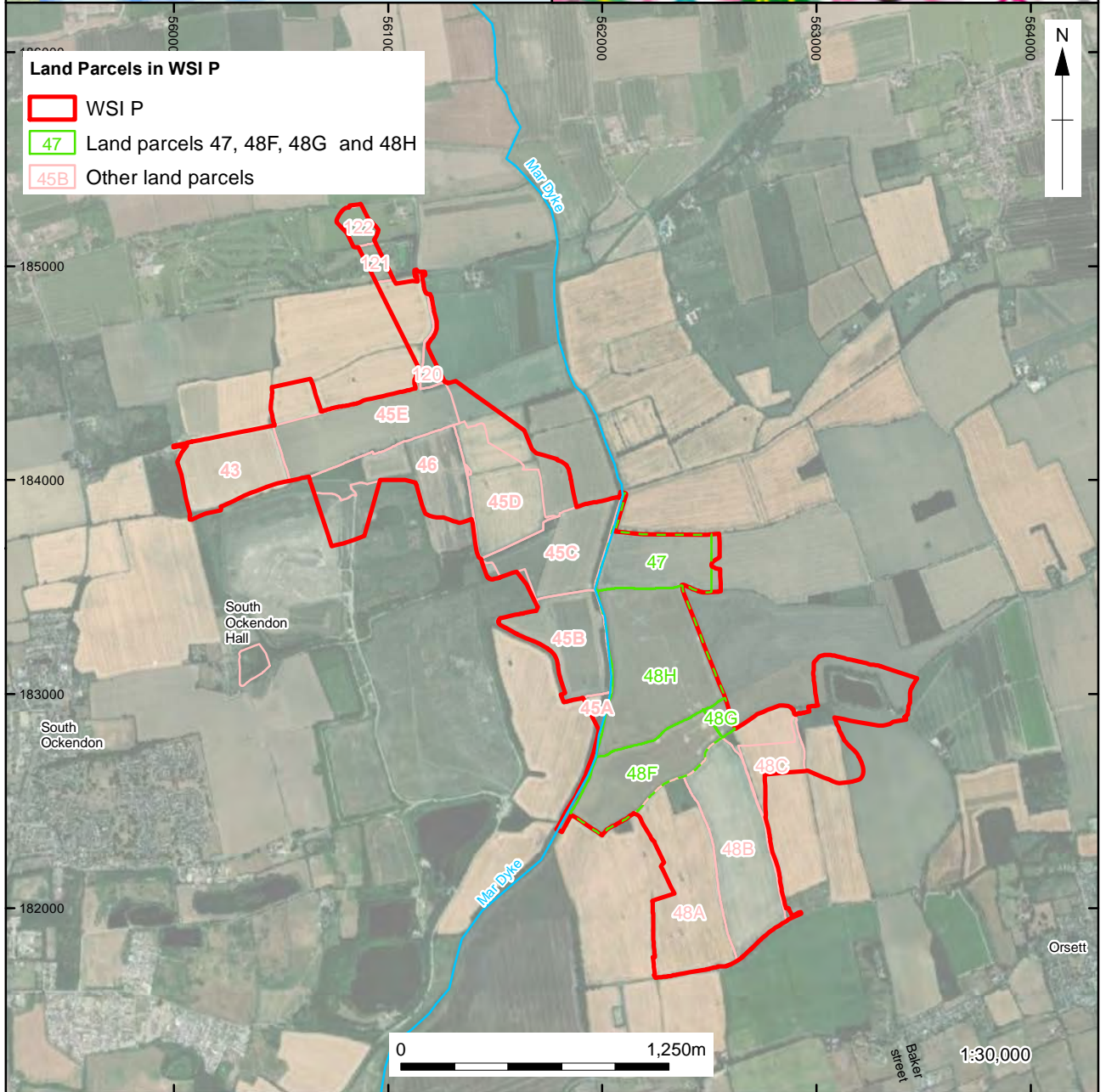
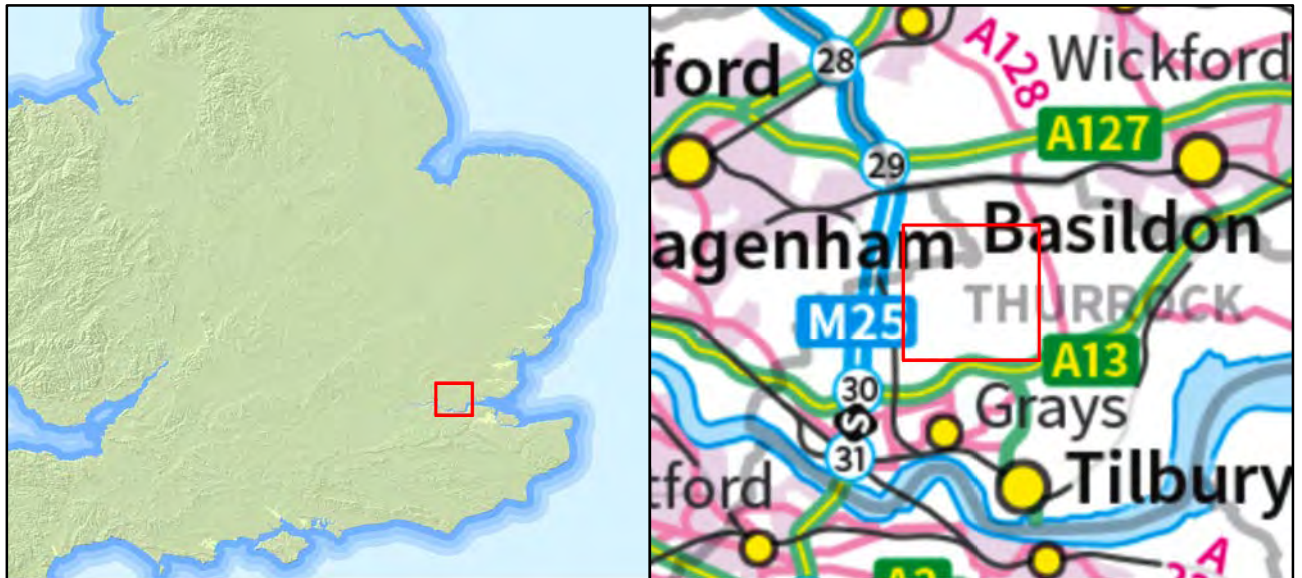

Source: Esri, Maxar, GeoEye, Earthstar Geographics, CNES/Airbus DS, USDA, USGS, AeroGRID, IGN, and the GIS User Community
 Contains Ordnance Survey data © Crown copyright and database right 2016

Figure 1: Map showing the location of the Mar Dyke valley evaluation area

\\10.0.10.86\Projects\1010\Geomatics\03 GIS Projects - LTC43M21\Figures\LTC43M21_CENTRE_Fig1.mxd*caroline.souday*25/02/2022

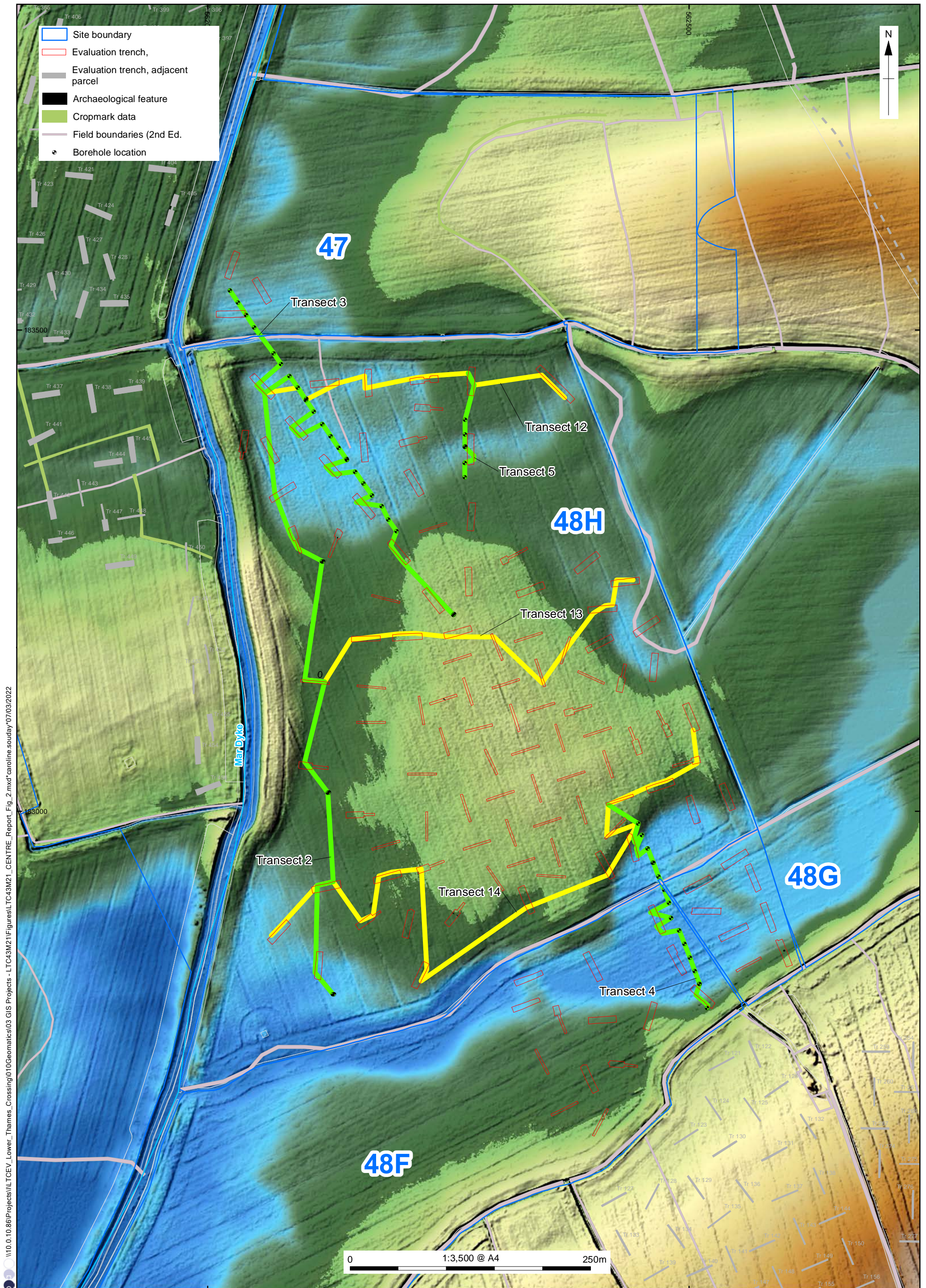

Contains public sector information licensed under the Open Government Licence v3.0 (Environment Agency)

Figure 2 : Trench and borehole layout of Land Parcels 47 and 48f-h

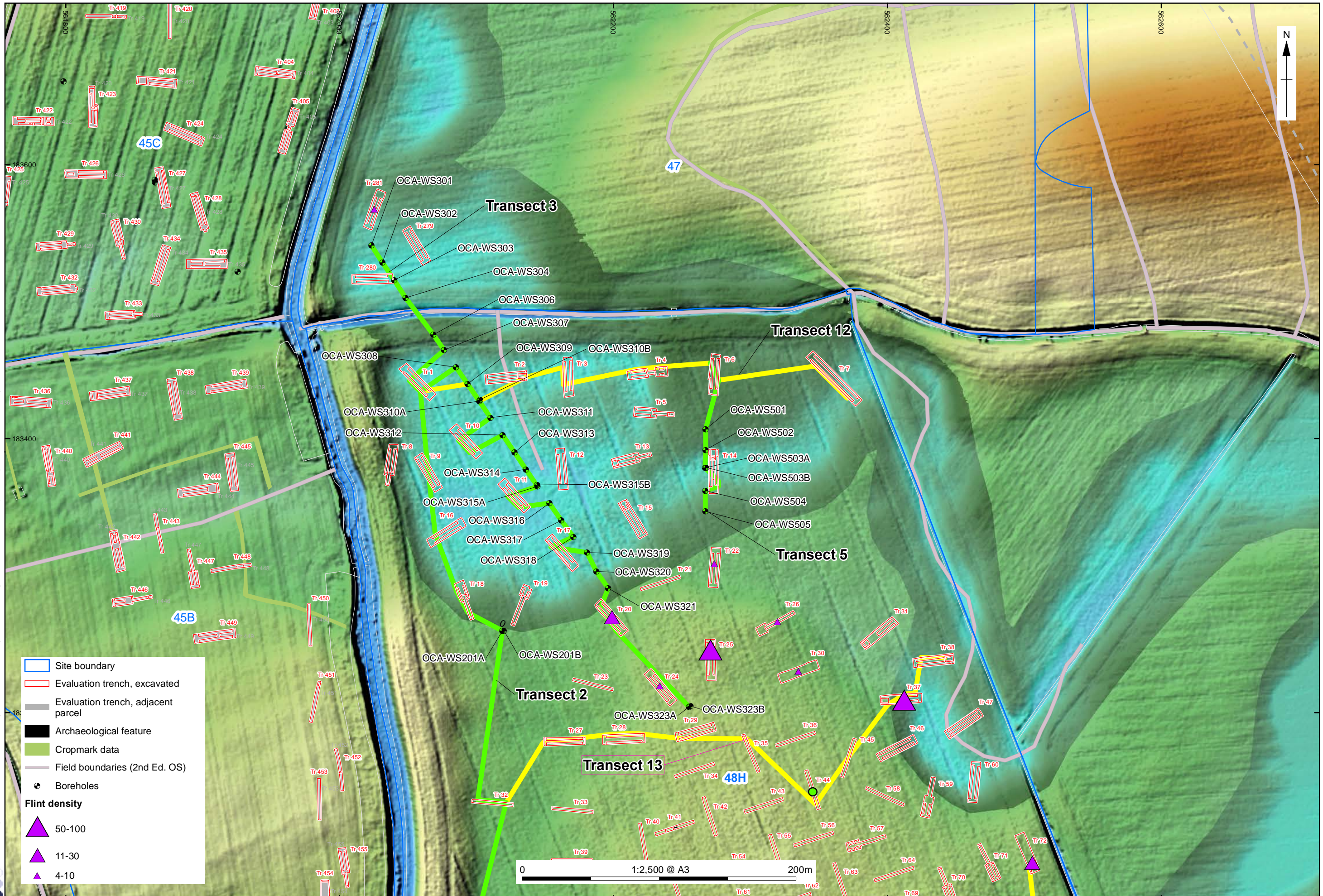

I:\10.10.86\Projects\TCEV_Lower_Thames_Crossing\010\Geomatics\03 GIS Projects - L\TC3M2\Figures\TC3M2_L_CENTRE_Report_Sitelayout_DD.mxd\caroline_soudry\08\03\2022

Contains public sector information licensed under the Open Government Licence v3.0 (Environment Agency)

Figure 3: Overview of trenches and archaeological features in the northern area

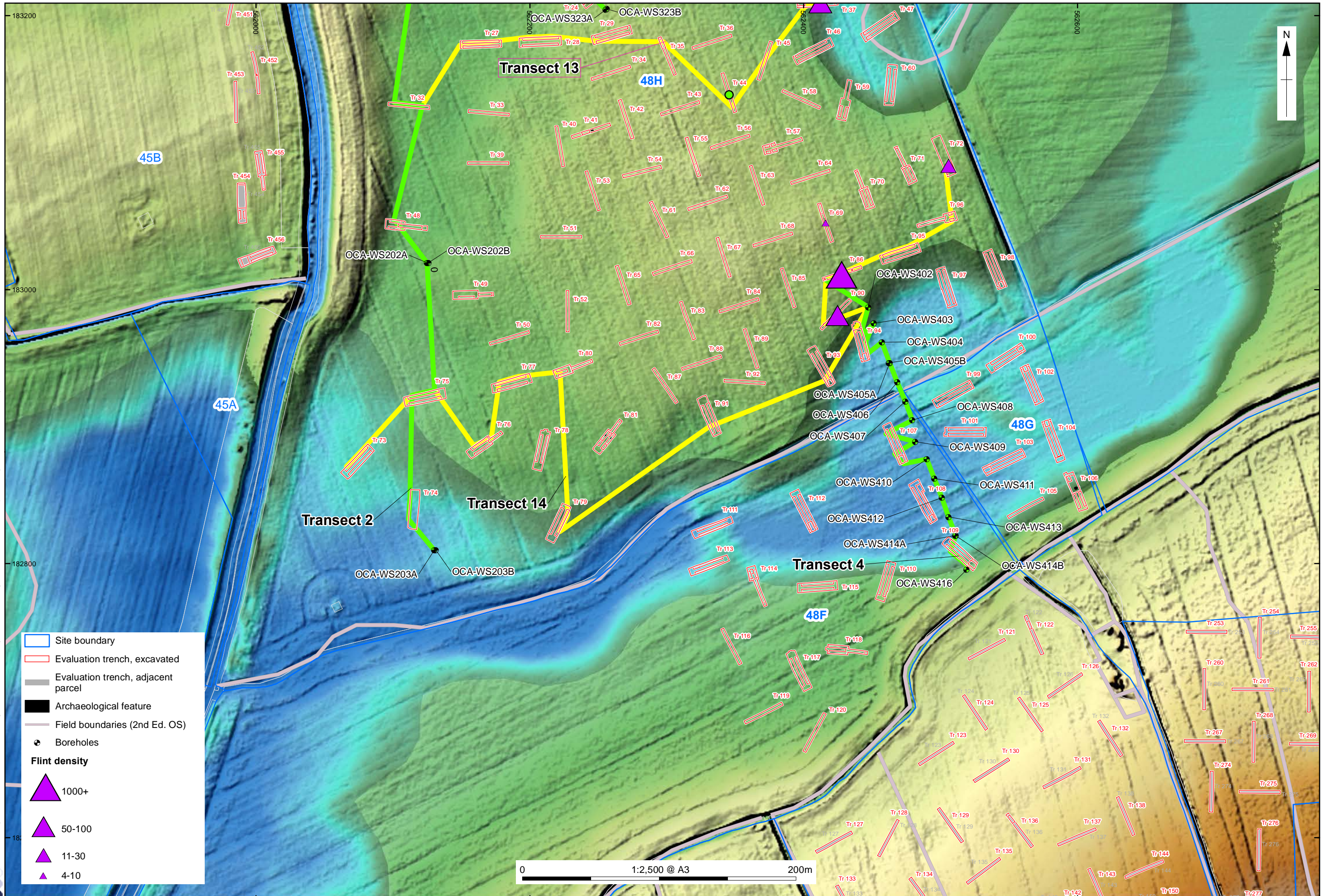

Contains public sector information licensed under the Open Government Licence v3.0 (Environment Agency)

Figure 4: Overview of trenches and archaeological features in the southern area

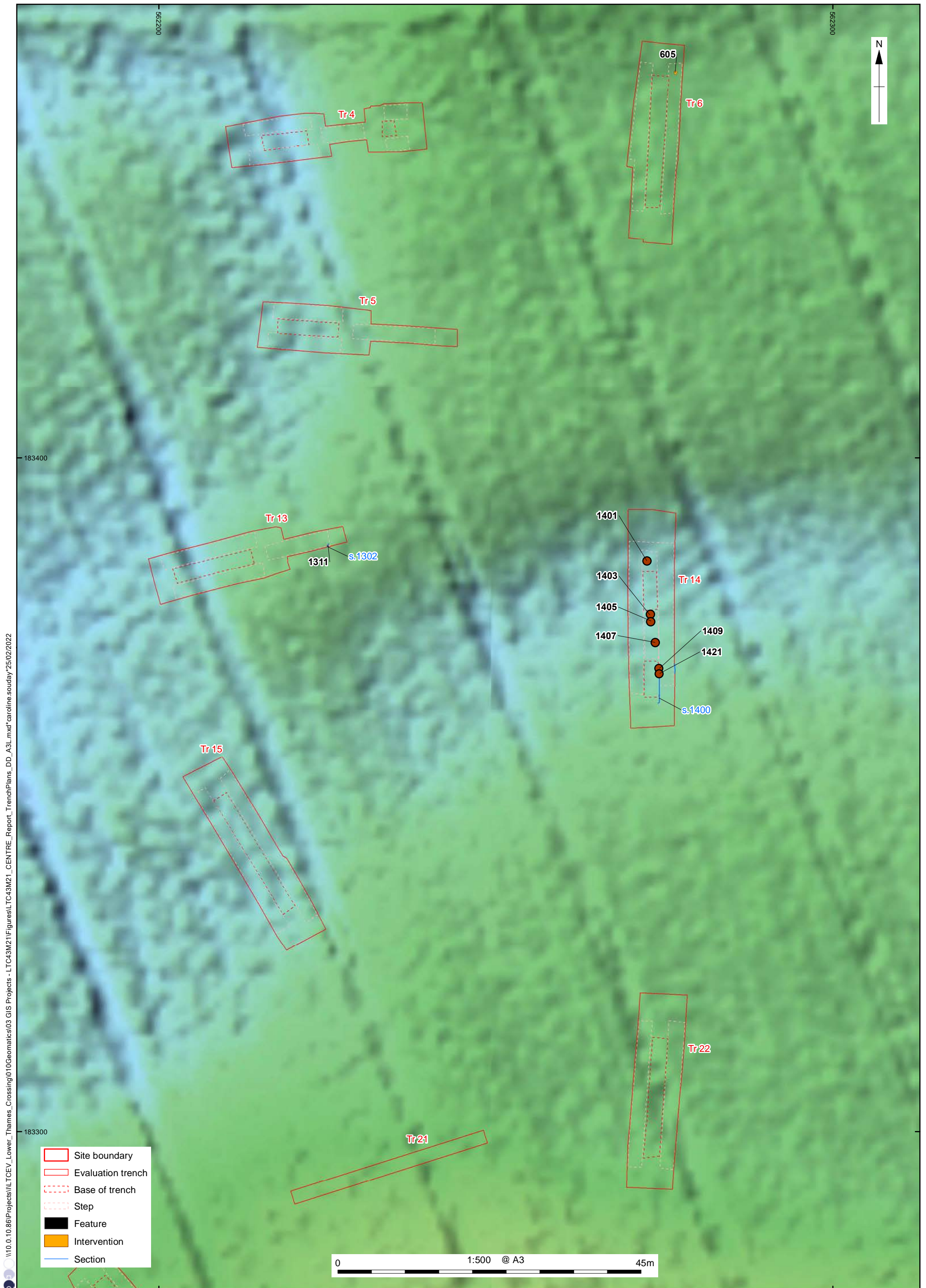

Figure 5: Detailed plan of Trenches 6, 13 and 14

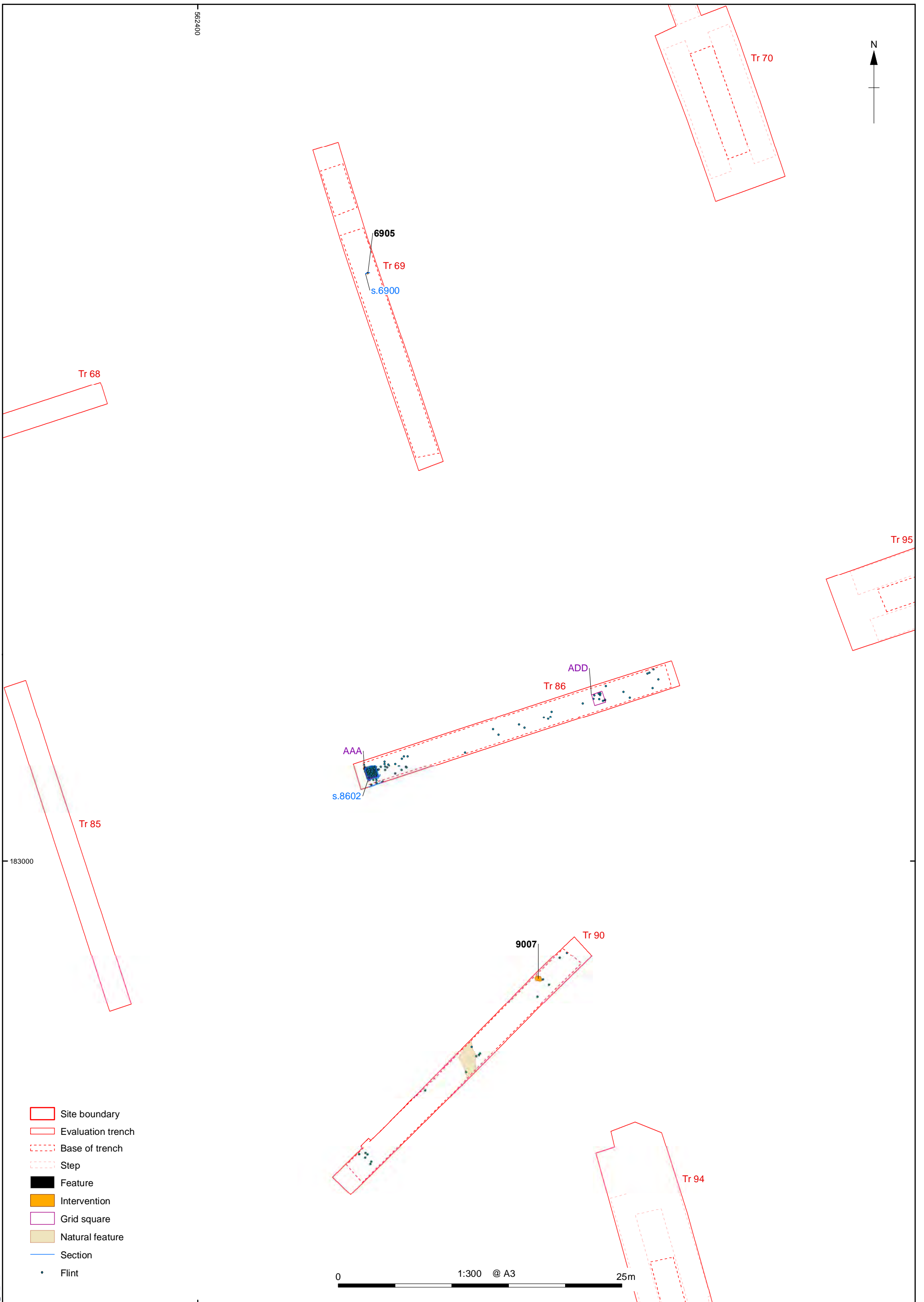
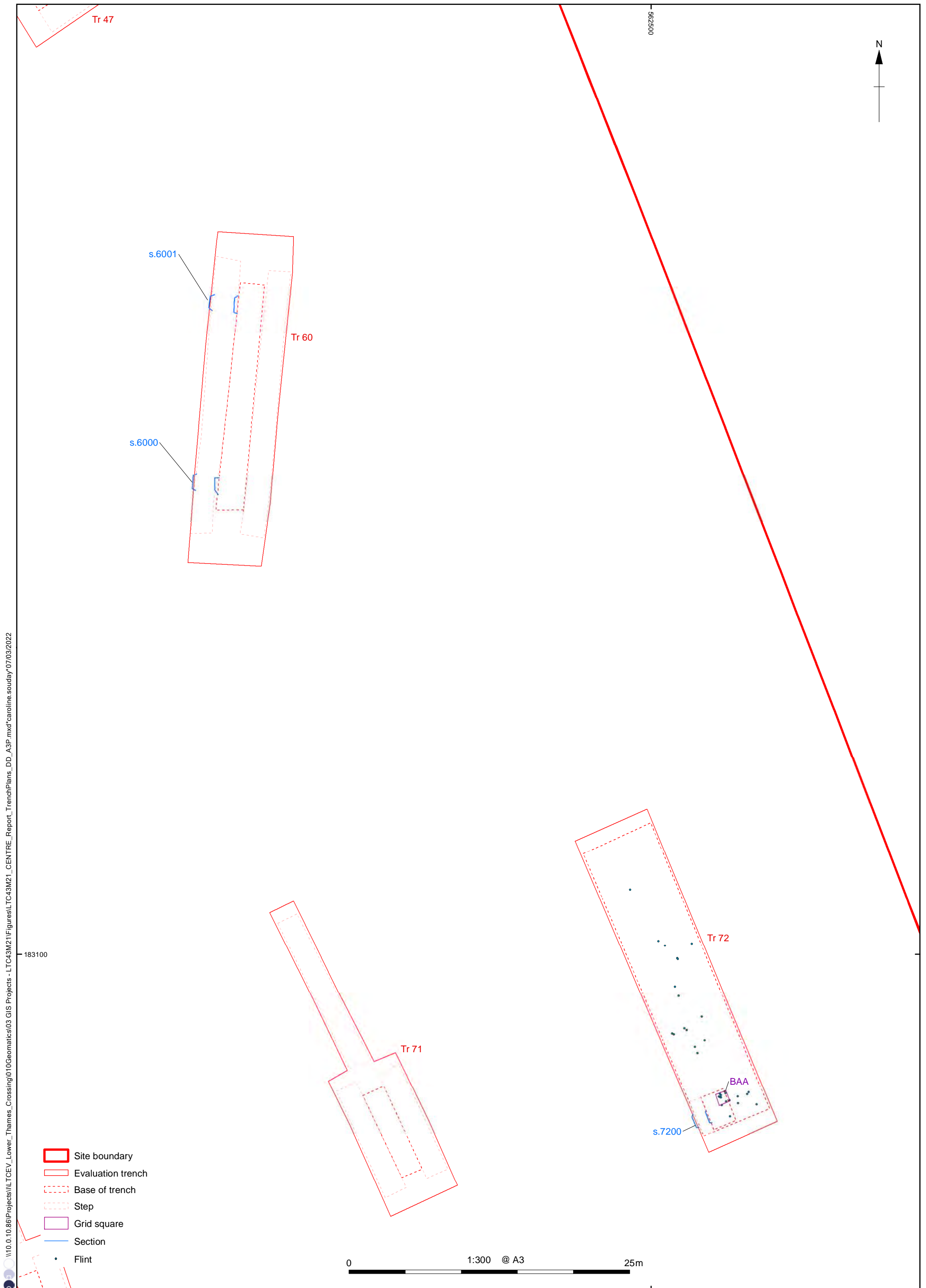

Figure 6: Detailed plan of Trenches 69, 86 and 90



I:\10.0.10.86\Projects\Lower_Thames_Crossing\10\Geomatics\03 GIS Projects - LTC43M21\Figures\LTC43M21_CENTRE_Report_TrenchPlans_DD_A3P.mxd*caroline.souday*07/03/2022

Figure 7: Detailed plan of Trenches 60, 71 and 72

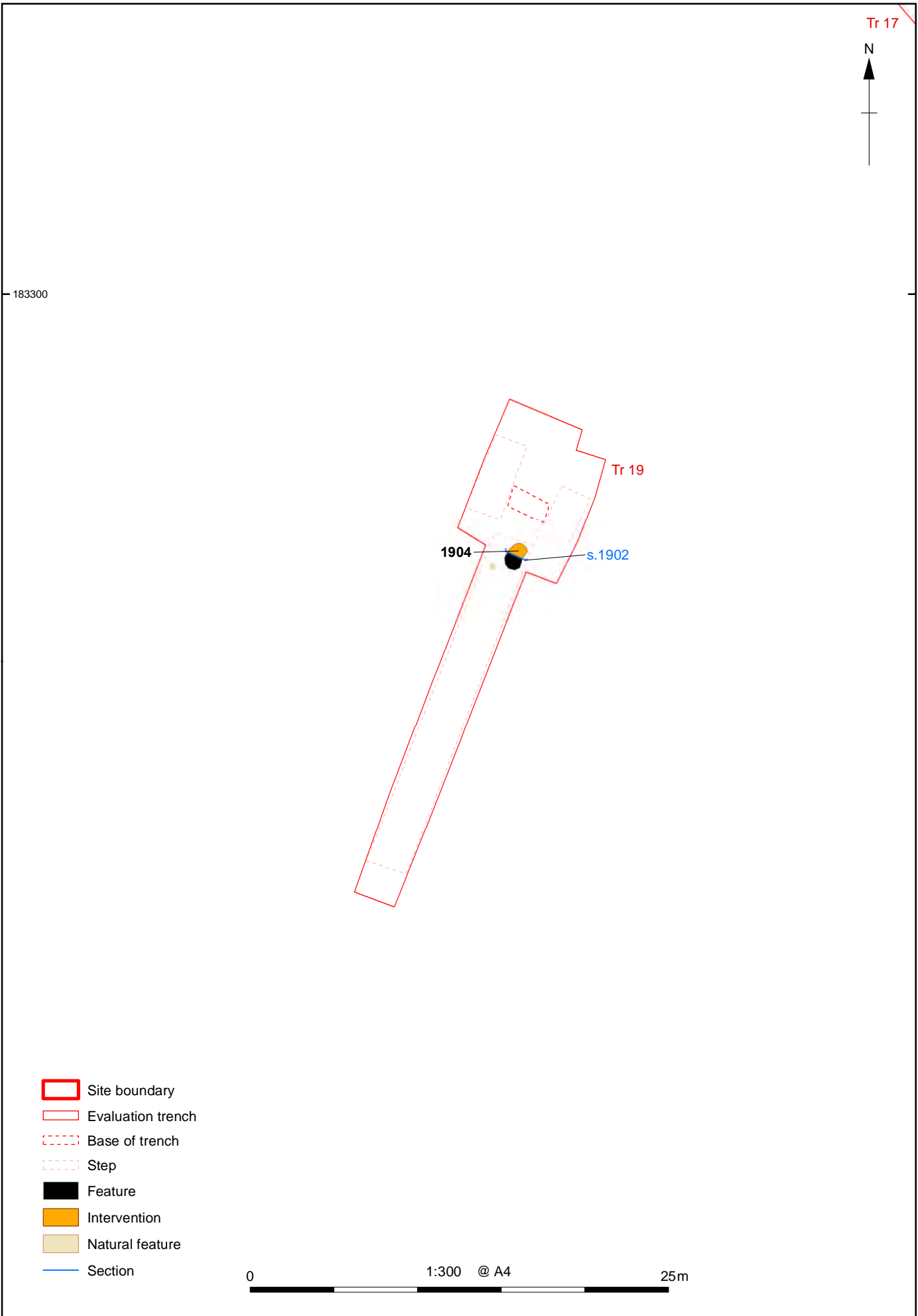

Figure 8: Detailed plan of Trench 19

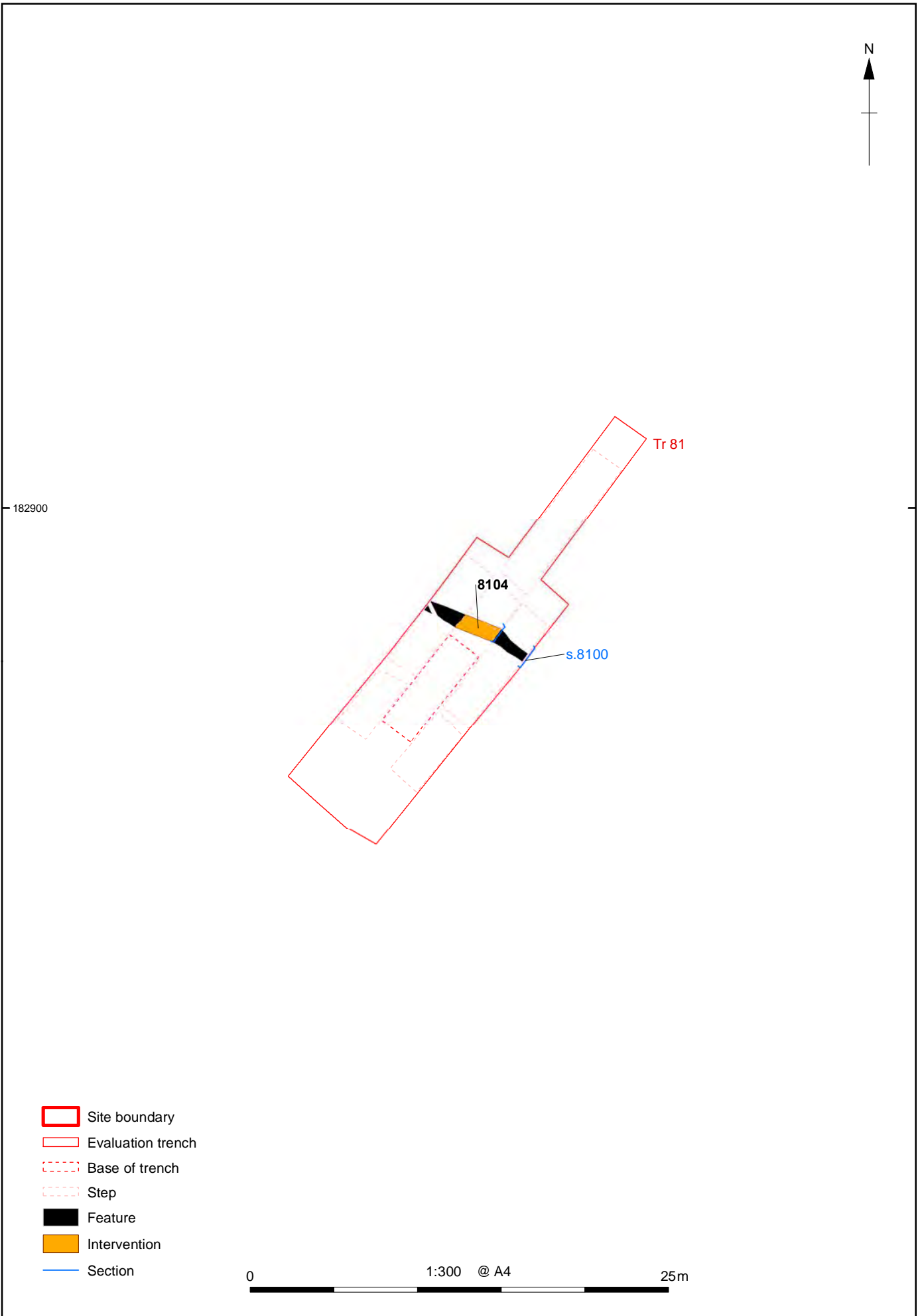

Figure 9: Detailed plan of Trench 81

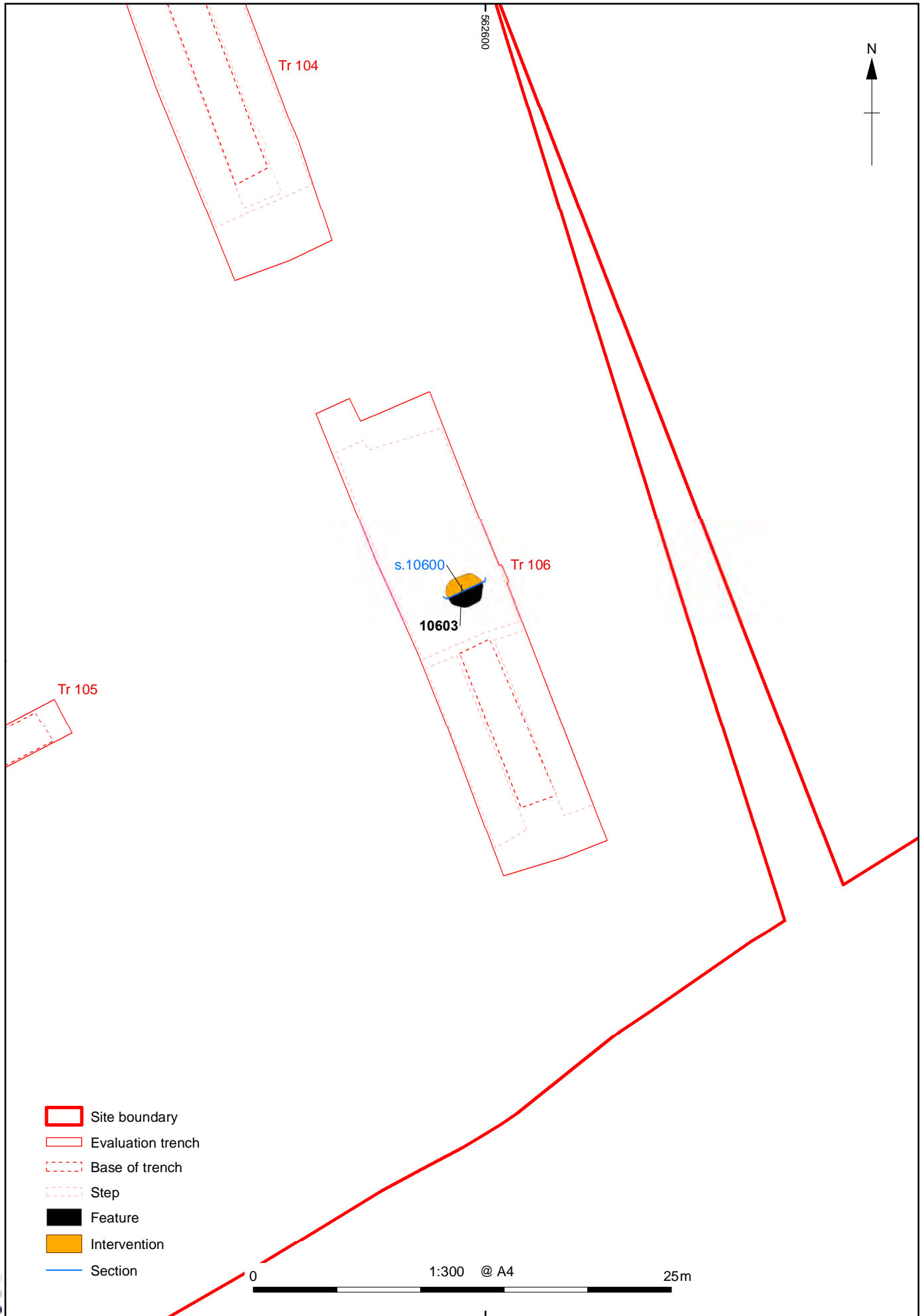

Figure 10: Detailed plan of Trench 106

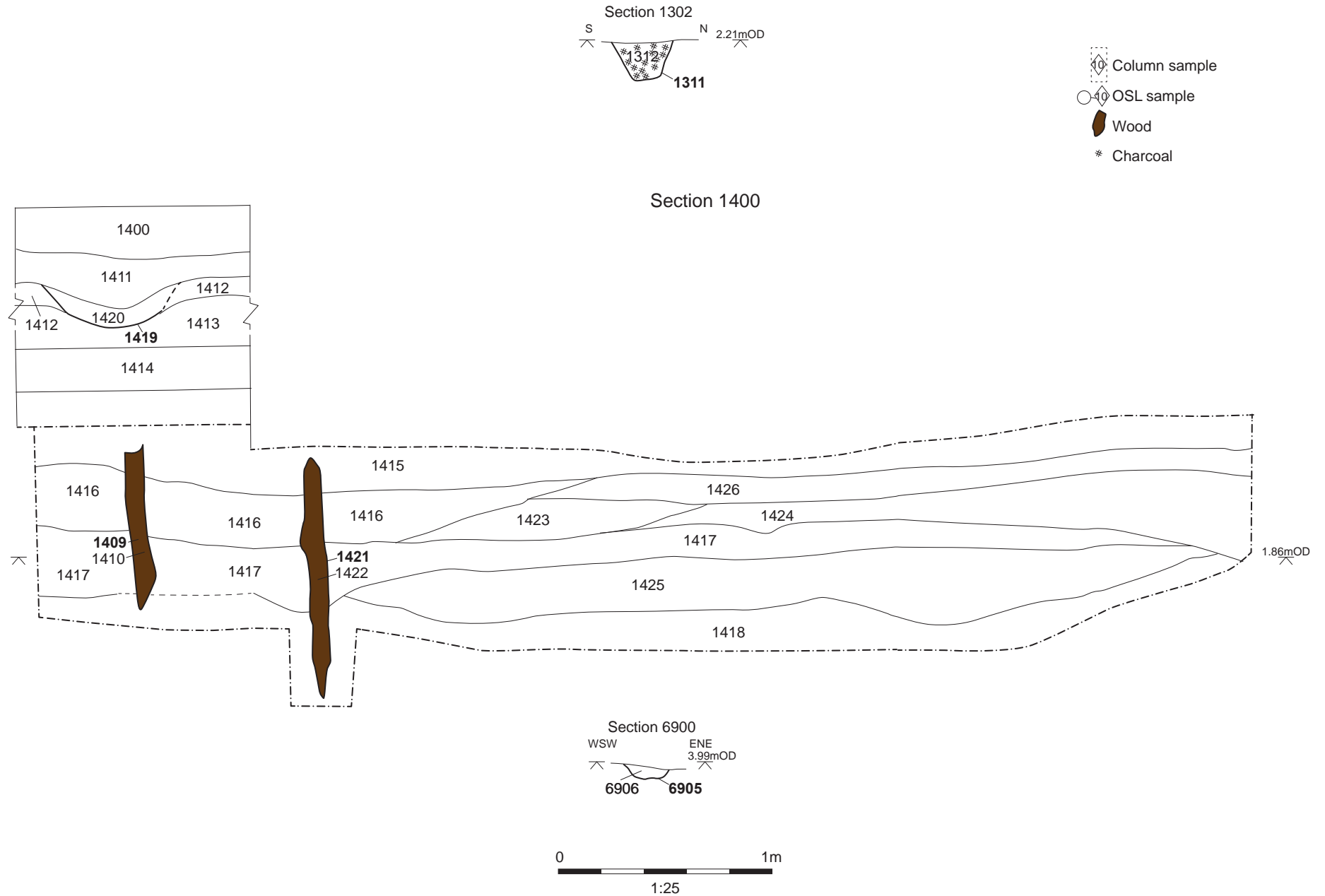

Figure 11: Sections 1302, 1400 and 6900

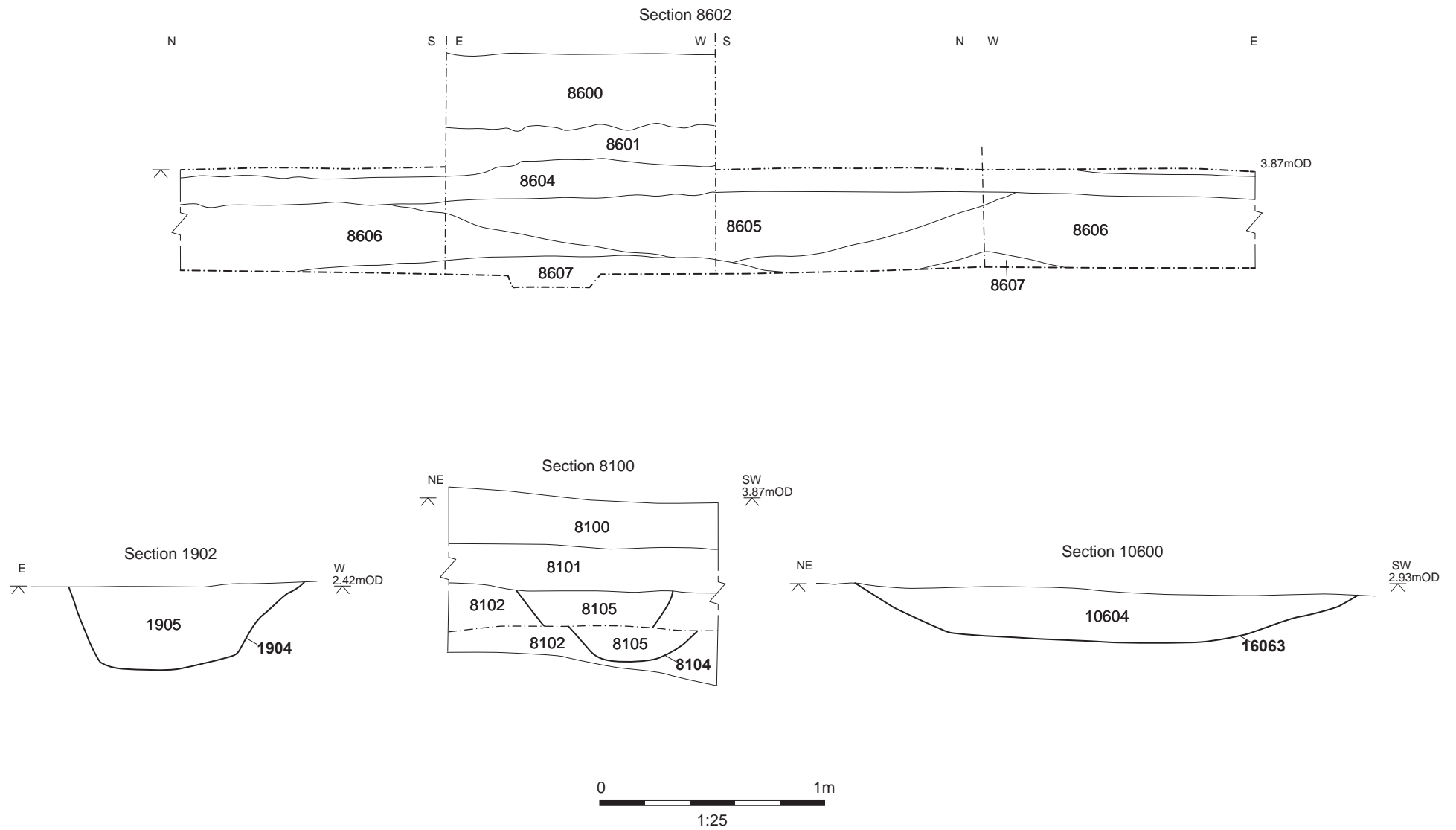

Figure 12: Sections 8602, 1902, 8100 and 10600

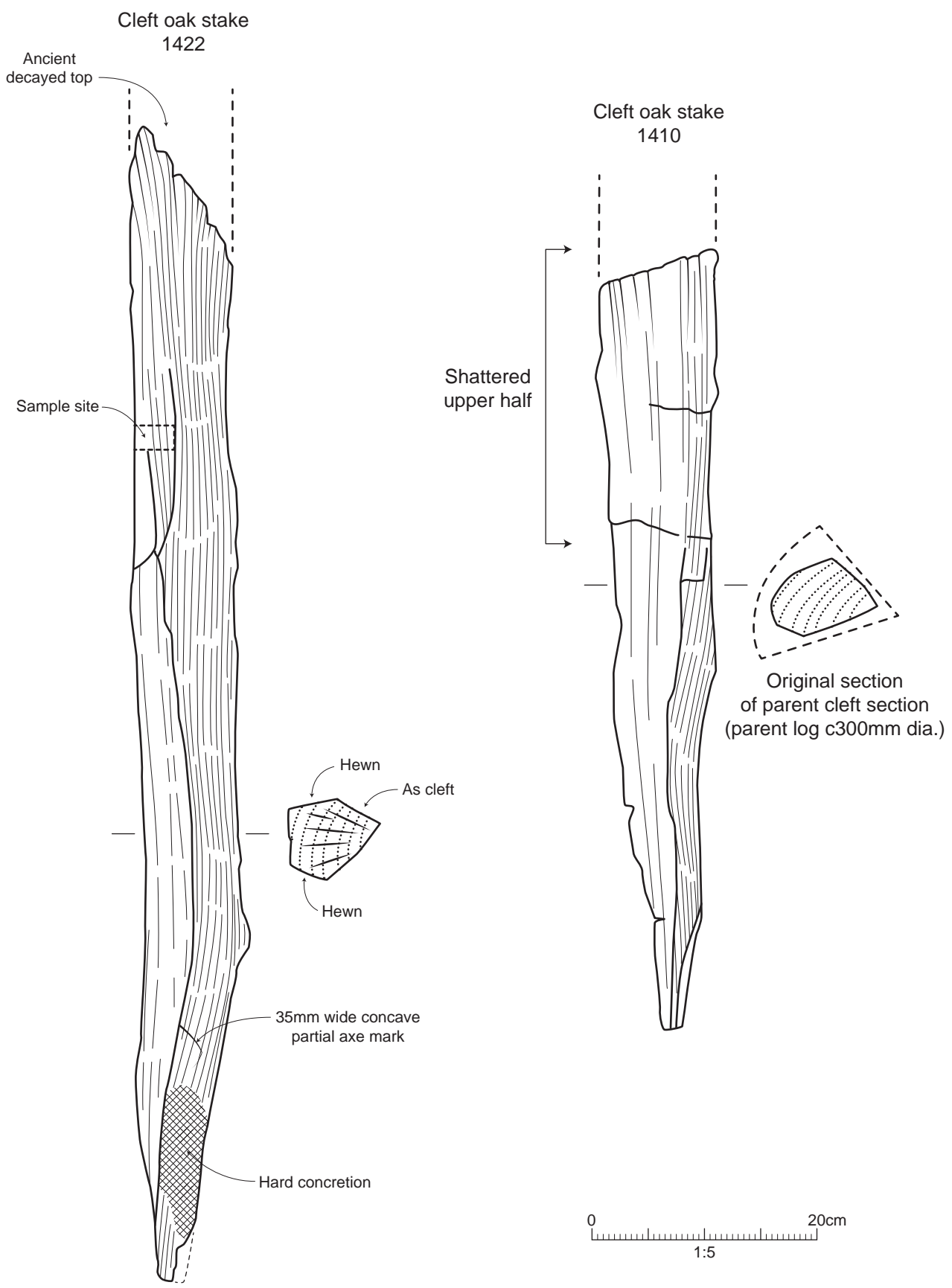

Figure 13: Detail of wooden stakes 1410 and 1422 from the structure in Trench 14

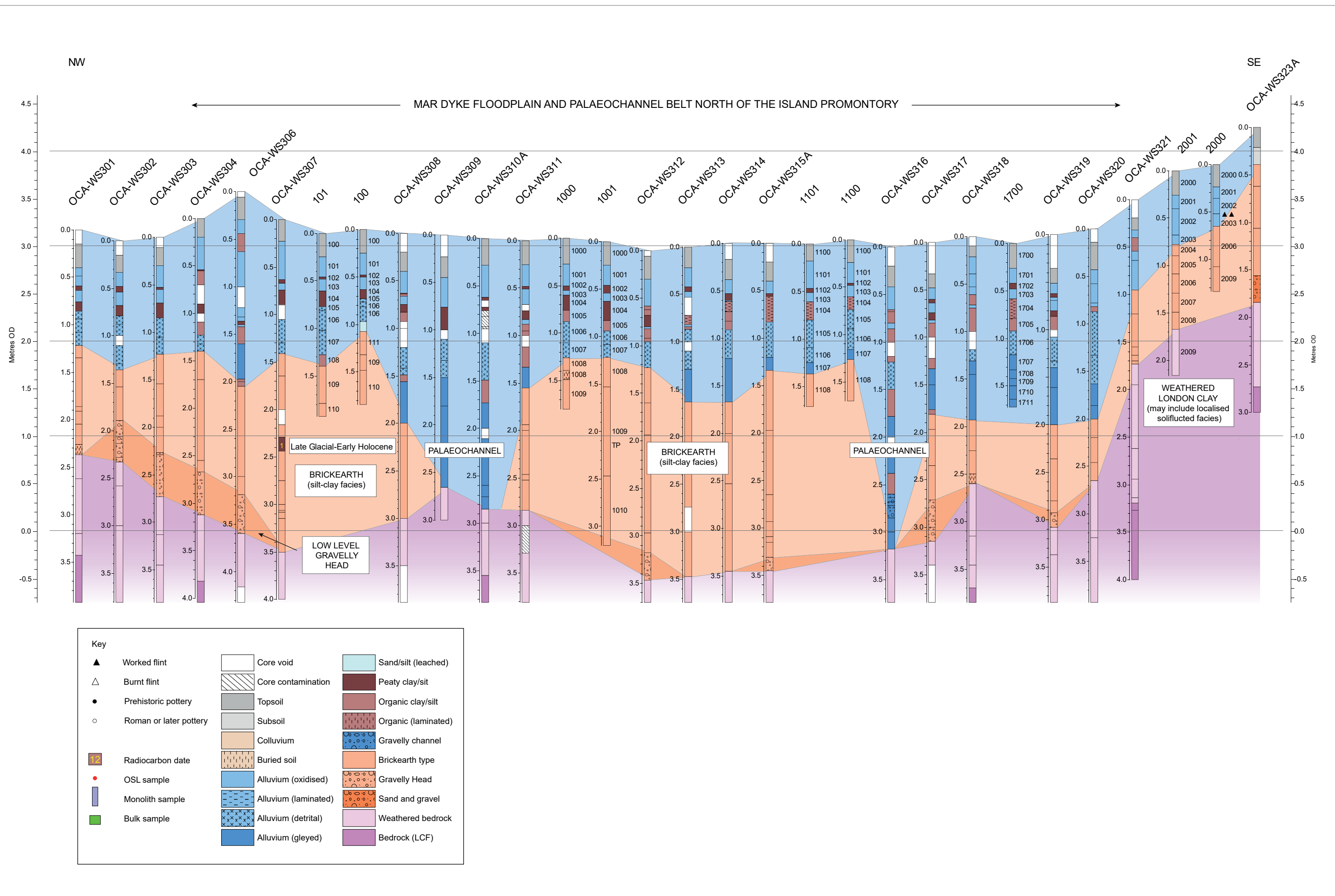

Figure 15: Geoarchaeological Transect 3, Boreholes OCA-WS301 to OCA-WS323A and Trenches 1, 10, 11, 17 and 20

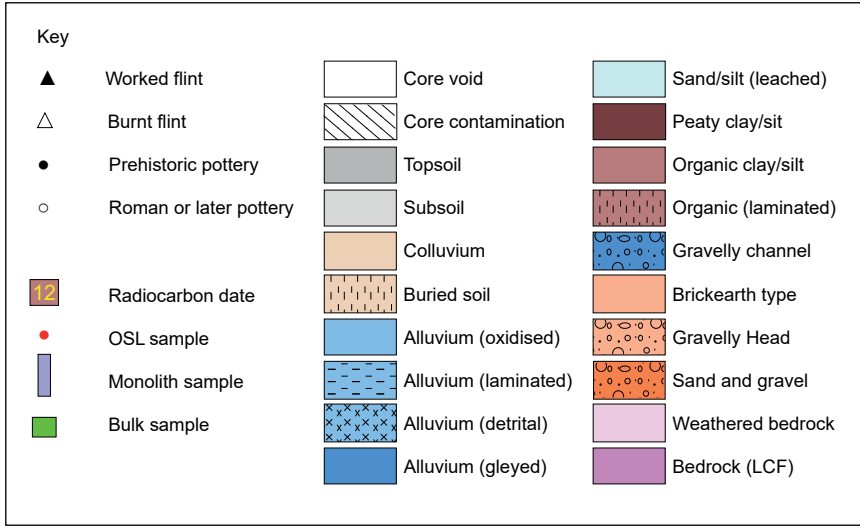
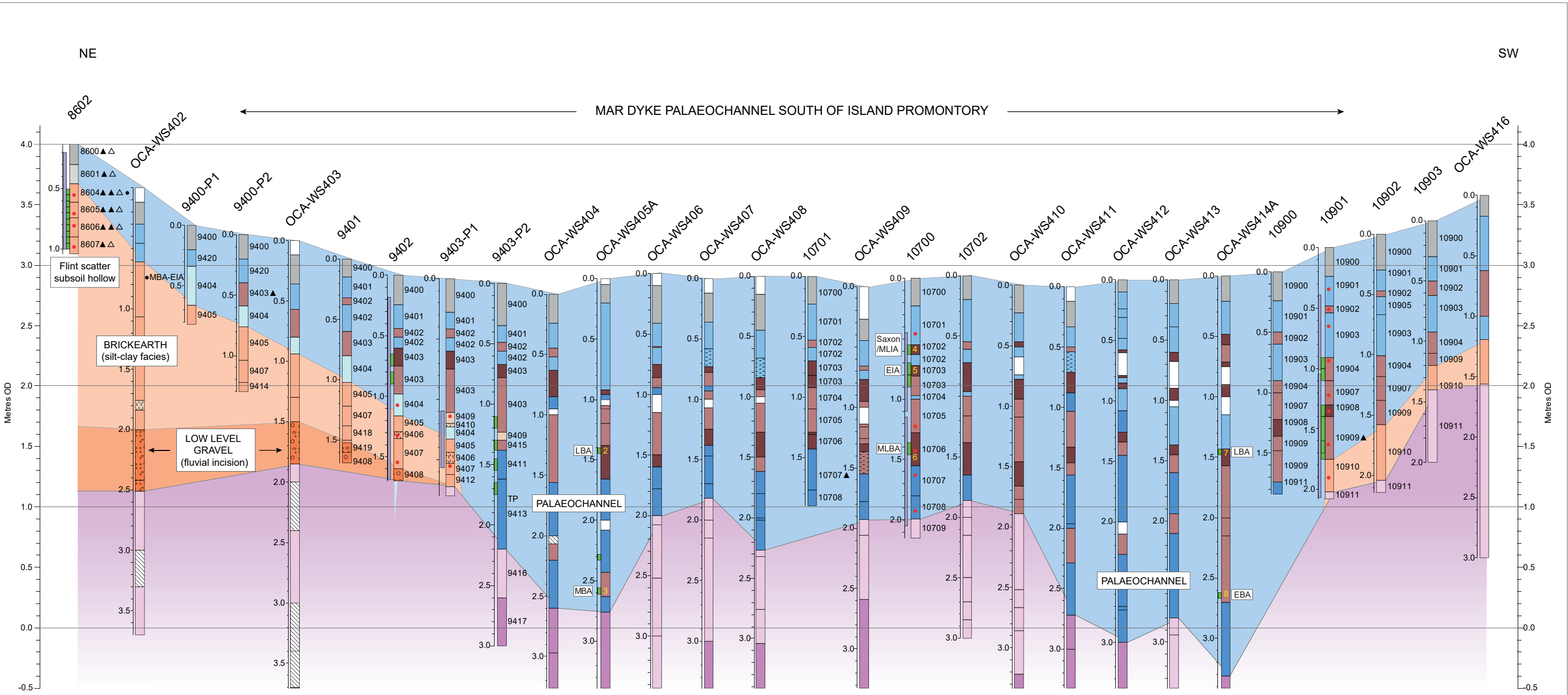

Figure 16: Geoarchaeological Transect 4, Boreholes OCA-WS402 to OCA-WS416 and Trenches 86, 94, 107-9

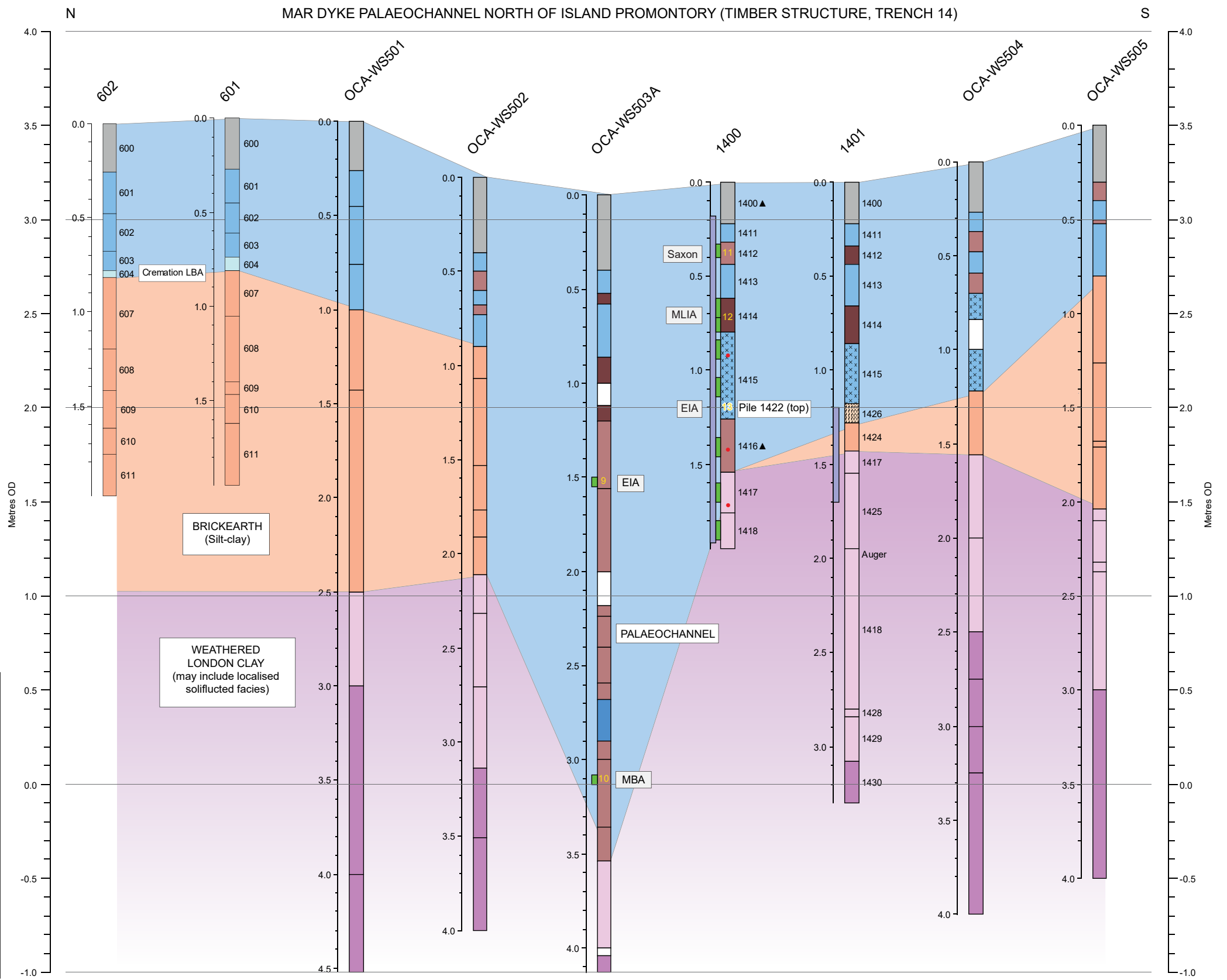

Figure 17: Geoarchaeological Transect 5, Boreholes OCA-WS501 to OCA-WS505 and Trenches 6 and 14

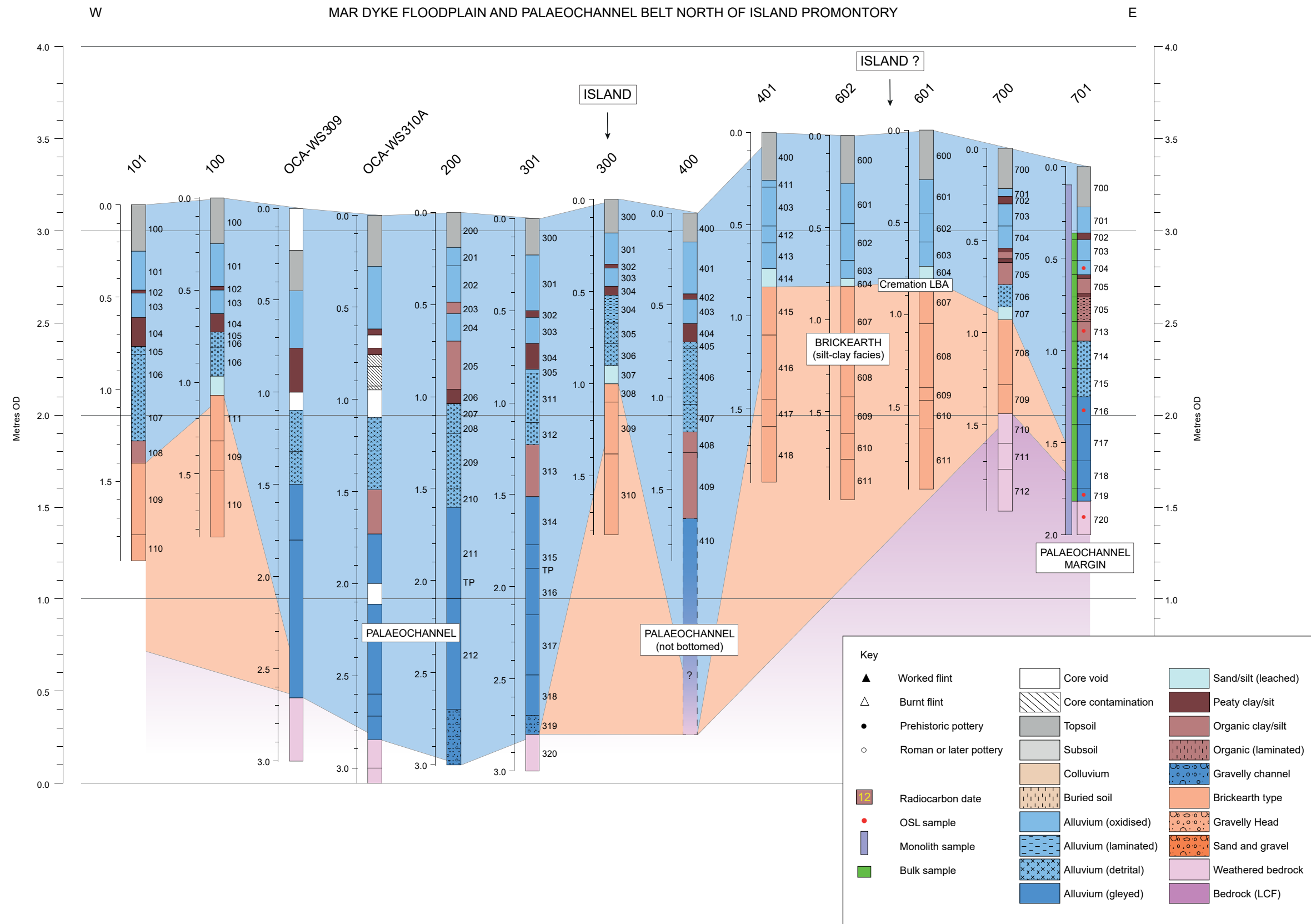

Figure 18: Geoarchaeological Transect 12, Boreholes OCA-WS39 and OCA-WS310A and Trenches 1-4, 6 and 7

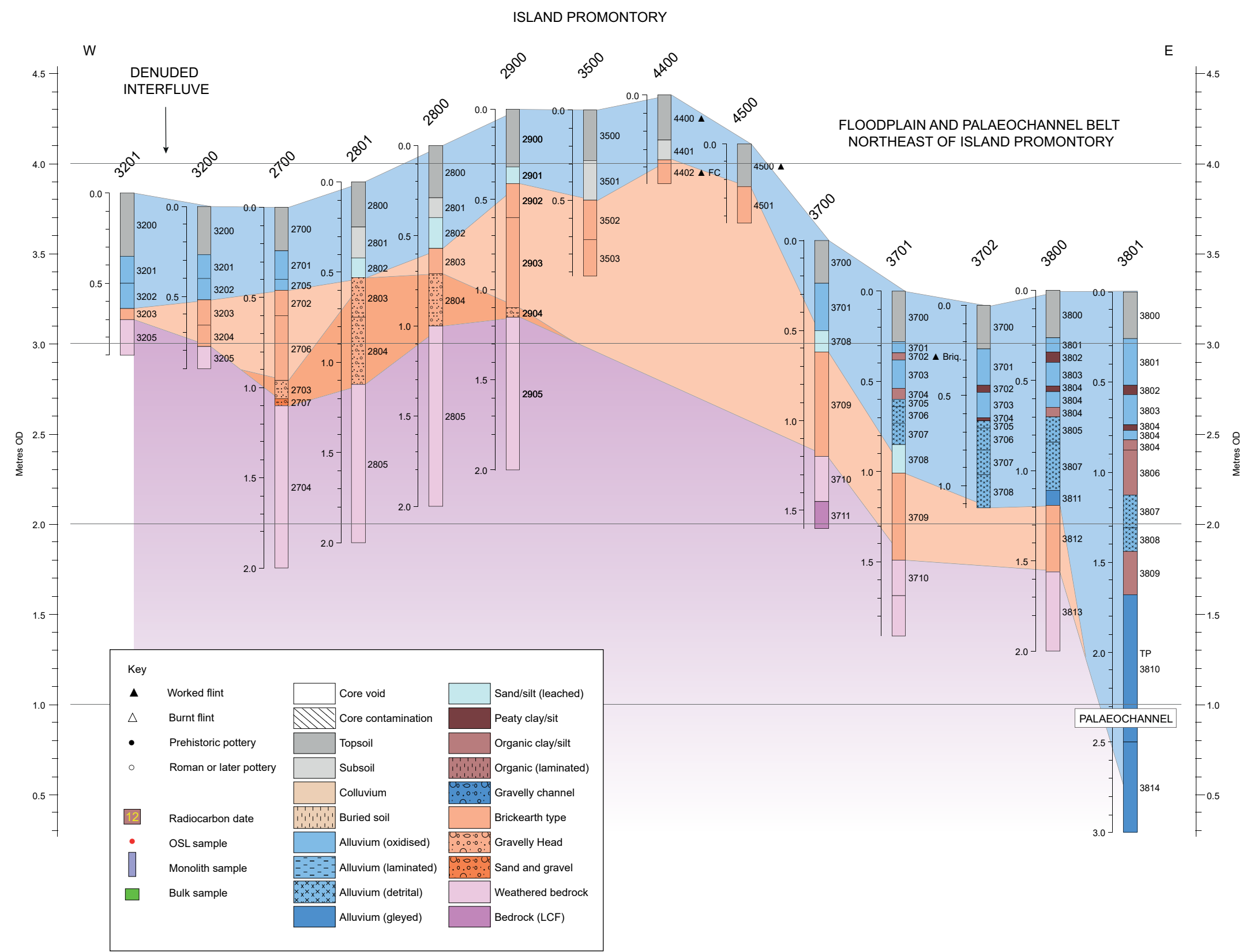

Figure 19: Geoarchaeological Transect 13, Trenches 32, 27-9, 35, 44-5 and 37-8

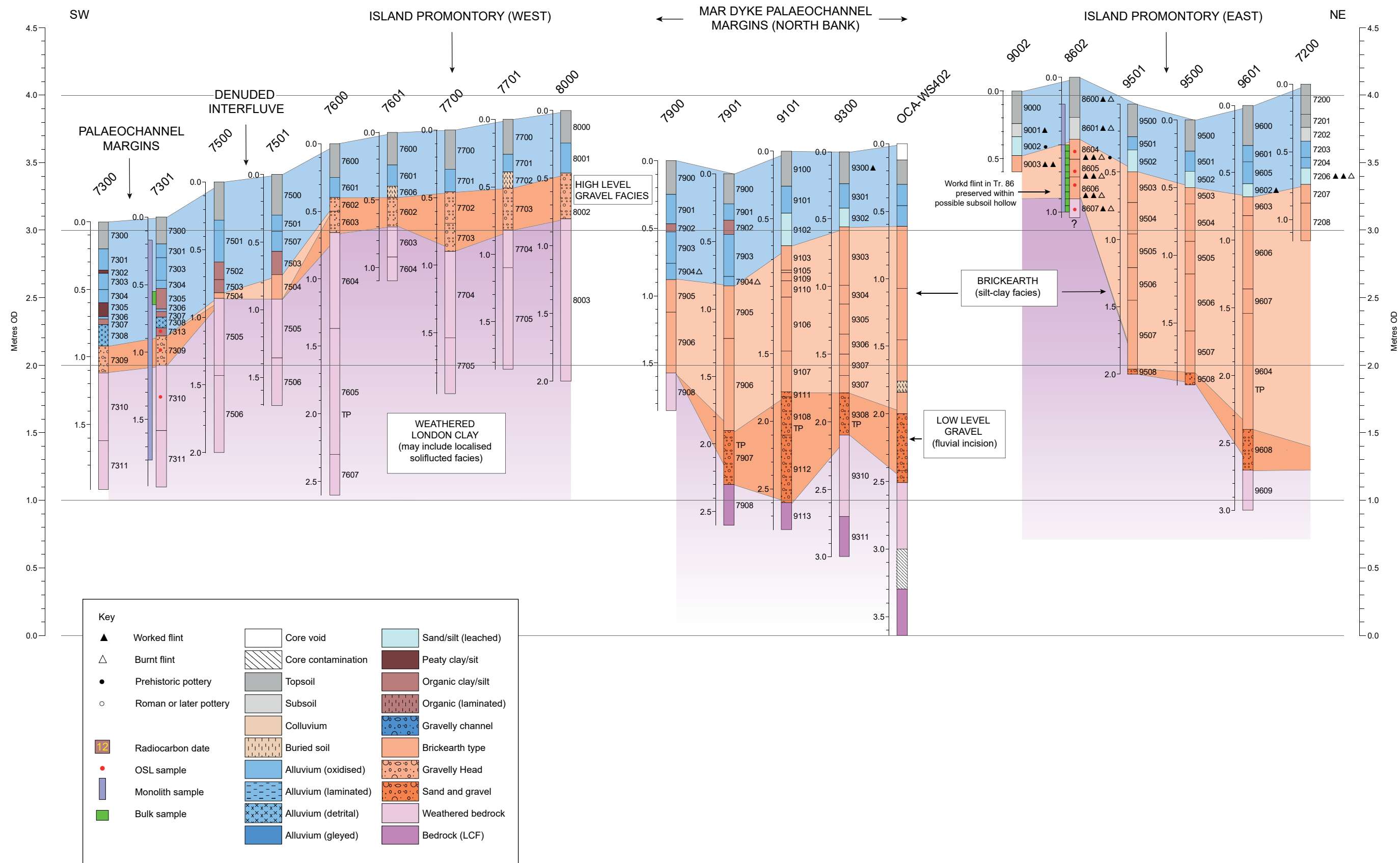

Figure 20: Geomorphological Transect 14, Borehole OCA-WS402 and Trenches 73, 75-7, 80, 79, 91, 93, 90, 86, 95-6 and 72



Plate 1: Cremation pit 605, looking south



Plate 2: Pit 1311, looking north-west



Plate 3: General view of Trench 14 with flags marking the locations of postholes 1403, 1405 and 1407, looking SSE



Plate 4: Timbers 1410 and 1422, looking east



Plate 5: Timber 1422, looking east



Plate 6: NNW facing section of Test Pit AAA (S.8602), Trench 86



Plate 7: Flint scatter 8603 in Test Pit AAA following excavation of Spit 2, looking WSW



Plate 8: Cremation pit 9007, looking north-west

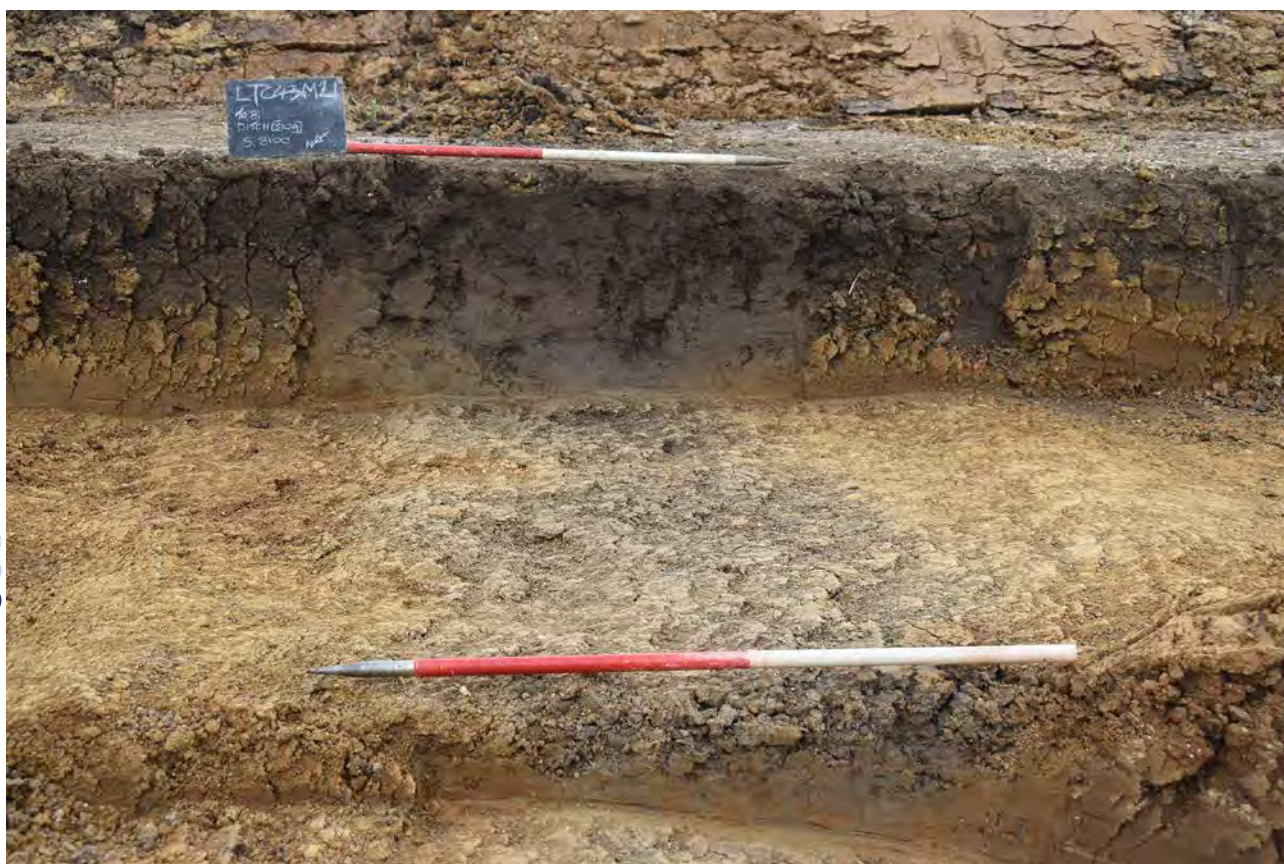

Plate 9: Ditch 8104 looking south-east



Plate 10: Possible pit 10603, looking south



Plate 11: Weathered bedrock overlain by brickearth and a thin alluvium, Borehole OCA-WS201A, 0-3m, Transect 2 (ground surface, top left)



Plate 12: Alluvial and peat sequence, Section 1601, Trench 16, Transect 2



Plate 13: Weathered bedrock overlain by gravelly Head, sealed by brickearth and intercalated Holocene alluvial and peat deposits, Borehole OCA-WS304, 0-5m, Transect 3 (ground surface, top left)



Plate 14: Peaty deposit at 2.29-2.44m BGL within brickearth, radiocarbon dated to the late Glacial or early Holocene, Borehole OCA-WS307, 0-4m, Transect 3 (ground surface, top left)



Plate 15: Organic, gleyed and gravelly detrital palaeochannel deposits (later prehistoric) overlying weathered bedrock, OCA-WS316, 0-5m, Transect 3 (ground surface, top left)



Plate 16: Basal low-level fluvial gravel beneath brickearth exposed at c 2m BGL in Section 9701, Trench 97



Plate 17: Organic and gleyed palaeochannel deposits (later prehistoric) overlying weathered bedrock, OCA-WS414A, 0-5m, Transect 4 (ground surface, top left)



Plate 18: Organic and gleyed palaeochannel deposits (later prehistoric) overlying weathered bedrock, OCA-WS405A, 0-5m, Transect 4 (ground surface, top left)



Plate 19: Organic and gleyed palaeochannel deposits (later prehistoric) overlying weathered bedrock, Section 10700, Trench 107

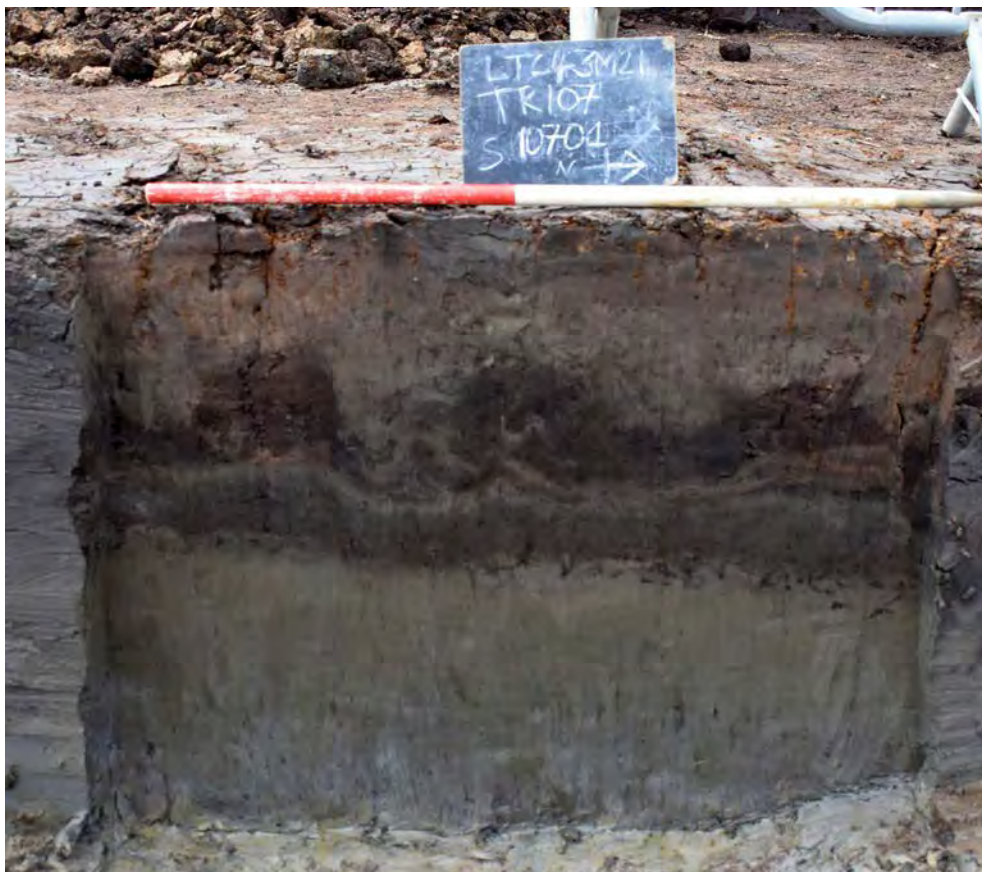

Plate 20: Eroded and disturbed peat deposits within the main palaeochannel, Section 10704, Trench 107



Plate 21: Eroded peat clasts and fine sandy laminations within the main palaeochannel, Section 9701, Trench 97



Plate 22: Organic and gleyed palaeochannel deposits (later prehistoric) overlying weathered bedrock, OCA-WS503A, 0-5m, Transect 5 (ground surface, top left)



Plate 23: The sediment sequence associated with stake 1410 of the timber structure in Section 1400, Trench 14, Transect 5. Stake 1422 adjacent was radiocarbon dated to the early Iron Age, 760-410 cal BC



Plate 24: Organic and gleyed palaeochannel deposits (later prehistoric) Section 3801, Trench 38, Transect 13



Plate 25: Higher level gravel deposits in Section 7601, Trench 76, Transect 14



Plate 26: Basal sand and gravel overlain by brickearth and capped by alluvium, Section 9100, Trench 91, Transect 14. Note the leached horizon at the top of the brickearth

COVER SHEET

Title:	Archaeological Evaluation Report for Trial Trenching of Land Parcels 48B and 48C Mar Dyke Valley, between South Ockendon and Orsett
Project Name:	Lower Thames Crossing Enabling Works
Ref No:	HE540039-BAL-GEN-GEN-REP-HER-00041
Revision No:	P01
Review Date:	29/11/2021
Status:	S2 – For Information
No. of Pages	166

Rev	Date of Issue	Revision Status	Originator	Checker	Approver
P01	29/11/2021	S2	Conal Mundy	Jack Fletcher	Emily Erswell



Lower Thames Crossing

Archaeological Evaluation Report for Trial Trenching of
Land Parcels 48B and 48C
Mar Dyke Valley, between South Ockendon and Orsett

Document Number: HE540039-BAL-GEN-GEN-REP-HER-00041

November 2021



Revision	Production Date	Prepared by	Checked by	Approved for release by	Sections revised
1.1	November 2021	Mark Hewson Cotswold Archaeology	Richard Young, Principal Fieldwork Manager Cotswold Archaeology Tim Allen, Senior Project Manager, Oxford Archaeology	Steve Lawrence, Senior Project Manager Oxford Archaeology	

This Evaluation Report has been prepared for Highways England in accordance with the terms and conditions of appointment stated in the Lower Thames Crossing (LTC) Technical Partner Contract. LTC cannot accept any responsibility for any use of or reliance on the contents of this document by any third party.

Contents

Section	Page
Summary	8
Acknowledgements	9
1 Introduction	10
1.1 Project details and scope of work	10
1.2 Location, topography and geology	11
1.3 Previous investigations	11
1.4 Archaeological and historical background.....	11
2 Project Aims	19
2.1 General aims	19
2.2 Specific objectives	20
3 Methodology	21
3.1 Constraints.....	21
3.2 Methodology for the evaluation.....	21
4 Results	23
4.1 Introduction and presentation of results	23
4.2 General soils and ground conditions.....	23
4.3 General distribution of archaeological deposits	24
4.4 Trenches 127, 129, 130, 131-134, 136, 140, 142-144 and 148 (Fig. 3; Figs 6-12).....	24
4.5 Trenches 162, 163, 171, 178 and 179 (Fig. 3; Figs 13, 14 and 20)	26
4.6 Trenches 168, 170, 174, 175, 180, 181 and 182 (Fig. 3; Figs 14-16 and 20)	28
4.7 Trenches 184, 185, 187, 188, 190 and 192 (Fig. 4; Figs 17-20)	29
4.8 Trenches 194, 196, 197 and 199 (Fig. 4; Figs 18-21).....	31
4.9 Trenches 203, 204, 211, 212, 213 and 214 (Fig. 4; Figs 22, 23 and 27).....	31
4.10 Trenches 217, 218, 219, 222, 230, 233 and 250 (Fig. 4; Figs 24-7, 30 and 36).....	33
4.11 Trenches 226, 230, 231, 233, 234, 235 and 239 (Fig. 4; Figs 25-9)	34
4.12 Trenches 253, 255, 259, 265, 266, 273 and 276 (Fig. 5; Figs 31-3 and 35-6)	36
4.13 Trenches 254, 267 and 274 (Fig. 5; Figs 31, 34 and 36)	37
4.14 Finds summary	39
4.15 Environmental summary	39
5 Discussion	40
5.1 Reliability of field investigation	40
5.2 Interpretation.....	41
5.3 Evaluation objectives and results.....	43
Appendix A Trench Tables	45
Appendix B Finds Reports	96
Appendix C Environmental Reports	104

Appendix D	Geoarchaeological Report.....	108
Appendix E	References	111
Appendix F	Abbreviations and Glossary	113
Appendix G	Site Summary.....	114

Figures

Figure 1: Map showing the location of Land Parcels 48B and 48C

Figure 2: Plan of trenches, cropmark features and archaeological features

Figure 3: Detailed overview of north half of Land Parcel 48B

Figure 4: Detailed overview of south half of Land Parcel 48B

Figure 5: Detailed overview of Land Parcel 48C

Figure 6: Plan of Trenches 127, 133

Figure 7: Plan of Trenches 128-9 and 134-5

Figure 8: Plan of Trenches 129-30 and 136

Figure 9: Plan of Trenches 125 and 131-2

Figure 10: Plan of Trenches 140-2, 147 and 148

Figure 11: Plan of Trenches 143-4

Figure 12: Sections (Trenches 127, 129-34, 136, 142-4 and 148)

Figure 13: Plan of Trenches 162-164

Figure 14: Plan of Trenches 171-2 and 178-180

Figure 15: Plan of Trenches 167-8 and 170

Figure 16: Plan of Trenches 174-5 and 181-2

Figure 17: Plan of Trenches 184-5, 191-2 and 199

Figure 18: Plan of Trenches 187-8 and 194

Figure 19: Plan of Trenches 189-90 and 196-7

Figure 20: Sections (Trenches 162-3, 168, 170-1, 174-5, 178-9, 181, 184-5, 187, 190, 192, 194 and 196-7)

Figure 21: Plan of Trenches 198-9 and 205-6

Figure 22: Plan of Trenches 203-4

Figure 23: Plan of Trenches 211-14

Figure 24: Plan of Trenches 215 and 217-19

Figure 25: Plan of Trenches 222 and 229-31

Figure 26: Plan of Trenches 225-6 and 233

Figure 27: Sections (Trenches 199, 203-4, 211, 213-14, 217-19, 222, 230 and 233)

Figure 28: Plan of Trenches 234-5

Figure 29: Plan of Trench 239

Figure 30: Plan of Trench 250

Figure 31: Plan of Trenches 253-5

Figure 32: Plan of Trenches 257-9 and 264-6

Figure 33: Plan of Trench 273

Figure 34: Plan of Trenches 267-8 and 274-5

Figure 35: Plan of Trenches 276-7

Figure 36: Sections (Trenches 250, 253-5, 259, 265-7, 273-4 and 276)

Plates

Plate 1: Ditch 12703 looking NNW

Plate 2: Ditch 14403 looking north-west

Plate 3: Ditches 12904/12906 looking north-east

Plate 4: Ditch 13203 looking west

Plate 5: Ditch 13103 looking north

Plate 6: Ditch 14303 looking west

Plate 7: Ditch 13305 looking north-west

Plate 8: Pit 13307 looking north-west

Plate 9: Ditch 16303 looking north-east

Plate 10: Ditch 16803 looking west

Plate 11: Ditch 17403 looking west

Plate 12: Ditch 18103 looking east

Plate 13: Ditch 18107 looking east

Plate 14: Tree-throw 17503 looking north-west

Plate 15: Ditch 18403 looking south-east

Plate 16: Ditch 19203 looking south

Plate 17: Ditch 18503 looking north

Plate 18: Ditch 18703 looking east

Plate 19: Ditch 21703 looking west

Plate 20: Ditch 25005 looking north

Plate 21: Ditch 21803 looking north

Plate 22: Ditch 21903 looking north
Plate 23: Ditch 27603 looking north-east
Plate 24: Ditch 26503 looking north-east
Plate 25: Natural Feature 27403 looking west
Plate 26: Trench 122
Plate 27: Trench 136
Plate 28: Trench 146

Tables

Table 1: Summary and quantification of the pottery by context
Table 2: Catalogue of ceramic building material
Table 3: Catalogue of fired clay
Table 4: Breakdown of flint assemblage by type
Table 5: Summary of metal finds by context
Table 6: Summary of glass by context
Table 7: Assessment of CPR flots
Table 8: Summary of animal bones by context
Table 9: Assessment of molluscs from samples

Summary

Oxford Cotswold Archaeology was commissioned by Balfour Beatty to undertake a trial trench evaluation of Land Parcels 48B and 48C of the Lower Thames Crossing Pre-Enabling Works. Land Parcels 48B and 48C are located c 800m NW of the village of Baker Street in the historic parish of South Ockendon in Thurrock unitary authority within the county of Essex (NGR 561994 183659). The evaluation comprised 157 trenches and was completed between the 5th July and the 24th September 2021.

A total of 58 trenches revealed features of archaeological significance. These features were distributed across the site on the head clay deposits located on the southern slope of the Mar Dyke river valley with no particularly evident foci of activity.

The earliest activity was limited to two worked flints of Mesolithic origin. The occurrence of these artefacts in such small numbers suggests that activity during this period was little more than transitory.

The results suggest the site lay within the agricultural hinterland of the Iron Age and Roman settlement evaluated within Land Parcels 21 and 22, located on the high ground overlooking the southern slope of the Mar Dyke valley. Remains within the site principally comprised narrow, shallow cultivation or agricultural drainage ditches. A number of these were broadly aligned NE-SW and NNE-SSW and others more or less perpendicular to these on NW-SE and WNW-ESE alignments. The majority of these features remain undated but are considered likely to be associated with the few examples from which late Iron Age - early Roman and Roman pottery was recovered. A series of other ditches in Land Parcel 48C share similar characteristics but are aligned more north to south. A single abraded sherd of Roman pottery was recovered from one ditch.

The evidence recorded in Land Parcels 48B and 48C should be considered in conjunction with the results from the evaluation of Land Parcels 21 and 22. This suggests that the present investigation probably represents the outer element of the core settlement's agricultural hinterland.

Post-medieval field boundaries were encountered in both land parcels, which were also evident in the cropmark data and on 19th century historic mapping.

Acknowledgements

Oxford Cotswold Archaeology would like to thank the client, Balfour Beatty, for commissioning this project and managing the site safety and attendances. Thanks are also extended to the Historic Environment Consultants (Richard Havis and Katie Lee-Smith) of Place Services for Essex County Council advising the Borough of Thurrock, for monitoring and providing advice throughout the project.

The project was managed for Oxford Cotswold Archaeology by Steve Lawrence. The fieldwork was directed by Mark Dodd and Jack Easen, who were supported by Gregg Bowen, Rose Britton, Alex Capon, Bevan Cope, Jessica Domiczew, Alex Foley, Kerree Foster, Stephen Foster, Chris Griffiths, Christof Heistermann, Agata Kowalska, Harlie Mason, James McCallum, Tiger-Lily Mileto, Holly Owen, Tanja Peter, Ashley Pooley, Elodie Powell, Joan Roig, Marionna Sandin-Catacora, Joseph Smith, Molly Vowles and Kat Whitehouse. Site survey was undertaken by Caroline Souday and digitising was carried out by Gary Jones and Benjamin Brown.

Thanks are also extended to the teams of Oxford Cotswold Archaeology staff that cleaned and packaged the finds under the management of Natasha Dodwell and supervision of Carlotta Marchetto, processed the environmental remains under the management of Rebecca Nicholson and Natasha Dodwell and supervision of Martha Craven, and processed the digital images, scanned the records for security copying and prepared the archive under the management of Nicola Scott and supervision of Jody Bloom.

1 Introduction

1.1 Project details and scope of work

- 1.1.1 The Lower Thames Crossing Project is located between the A2 in Kent and the M25 in the London Borough of Havering. It will run underneath the River Thames through a tunnel and emerge on the northern side of the river at East Tilbury. From the North Portal the road will run to the M25 at Junction 29 via the A13 and pass between North and South Ockendon. The development of the project is managed by LTC, a partnership between Highways England and a consultancy joint venture set up to oversee the scheme.
- 1.1.2 A programme of archaeological trial trenching began in the Essex part of the scheme in November 2019. A scheme-wide specification for trial trenching was written by LTC (Highways England 2018), and in July 2019 LTC commissioned Balfour Beatty to deliver the pre-Enabling Works. Balfour Beatty appointed Oxford Archaeology (hereafter OA) to prepare a project-wide written scheme of investigation (WSI) for the scheme, which (at the request of the key archaeological stakeholders) is divided into two parts, one for the Kent section, the other for Essex and Havering (Oxford Archaeology 2019a, 2019b).
- 1.1.3 Following completion of the project-wide WSIs, OA was also instructed to prepare a series of site-specific or group-site specific WSIs for approval by the key archaeological stakeholders in advance of trial trenching to inform the Development Consent Order (DCO). A detailed WSI (WSI P) was created for Land Parcels 43, 45 – 48 and 120 – 125 prior to the trial trenching (Oxford Archaeology 2021). WSI P details the archaeological background and potential within these Land Parcels (Oxford Archaeology 2021). It also indicated the archaeological aims and objectives appropriate to the investigation of these Land Parcels by trenching and set out the methodology. This WSI was approved by Richard Havis, Principal Historic Environment Consultant for Place Services, Essex County Council, prior to the start of the fieldwork. Oxford Cotswold Archaeology was commissioned as Balfour Beatty's archaeological contractor to undertake the evaluation in accordance with the approved WSI and local and national planning policies. This trial trench evaluation report provides the results of the works in Land Parcels 48B and 48C specifically.
- 1.1.4 The fieldwork was completed between the 5th July and the 24th September 2021. All work adhered to the *Management of Research Projects in the Historic Environment: The MoRPHE Project Managers' Guide* (Historic England 2015) and the *Code of conduct* of the Chartered Institute for Archaeologists (CIfA) (CIfA 2014a, revised 2019). It also followed the *Standard and guidance for archaeological evaluation* and the *Standard and guidance for the creation, compilation, transfer and deposition of archaeological archives* (CIfA 2014b updated 2020; CIFA 2014c updated 2020).
- 1.1.5 The work was monitored by Richard Havis, Place Services, Essex County Council advising the Borough of Thurrock.

1.2 Location, topography and geology

- 1.2.1 Land Parcels 48B and 48C are located c 800m NW of the village of Baker Street (Fig. 1) in the historic parish of South Ockendon in Thurrock unitary authority within the county of Essex (NGR 561994 183659). Both land parcels are roughly rectangular, though land parcel 48C tapers to a point at its southern end. Together they cover an area of 29.71ha. These land parcels are bounded to the west and north by agricultural fields, to the east by further agricultural fields and to the south by Green Lane. An unmetalled north-south length of Green Lane also lies between the two land parcels. These land parcels are hereafter referred to as the 'site'.
- 1.2.2 The bedrock geology of the site is London clay formation (clay, silt and sand). The superficial geology is head clay (clay, silt, sand and gravel) located on the southern slopes of the Mar Dyke river valley (Fig. 2). Both land parcels are currently in use as part of two large agricultural fields; Land Parcel 48B in pastoral use and 48C in arable use.
- 1.2.3 The site is situated on a slope on the southern side of the Mar Dyke valley. The Mar Dyke itself is located 700m west of the land parcels. The southern edge of the site is situated on the southern river valley slope at a height of c 13m above Ordnance Datum (aOD), the ground sloping downwards to the north, with the lowest point of the site along its northern edge at c 5m aOD. Colluvial Head deposits have accumulated along the slopes of the river terrace and within the Mar Dyke river valley.

1.3 Previous investigations

- 1.3.1 No known below-ground archaeological investigations have been undertaken within the site previously.
- 1.3.2 Elsewhere, in 1993-94, Wessex Archaeology conducted several watching briefs in the vicinity of the wider site as part of the Horndon to Barking Natural Gas Transmission Pipeline investigations. One of these watching briefs was undertaken c 2km to the north-west of the site, where a SW-NE aligned ditch was found, which contained Bronze Age pottery (Oxford Archaeology 2021).
- 1.3.3 In the mid-19th century a Roman settlement and a possible Roman cemetery was excavated by labourers in the vicinity of the site, though there is some confusion about its location. The HER places this excavation to the north of the site, whilst Pastscape places it further to the west (Oxford Archaeology 2021).

1.4 Archaeological and historical background

- 1.4.1 The chronological summary of known archaeology given below is taken from WSI P (Oxford Archaeology 2021). The site is situated on the southern slope of the Mar Dyke river valley where, c 500m to the south, Holocene prehistoric features, findspots and cropmarks have been identified. The cropmarks that have been recorded within and around the site are those mapped by the Aerial Investigation and Mapping report (Place Services 2019). These cropmarks are shown on Figure 2.

- 1.4.2 **Palaeolithic.** No Palaeolithic finds have been recorded within 1km of the site. A Palaeolithic handaxe was found on the ground surface c 1.5km north-west of the site at South Ockendon Hall. The find was discovered in 1978 when a windmill on the south side of the moat was demolished. This object may have been disturbed during the excavation of the nearby moat.
- 1.4.3 **Mesolithic.** No known Mesolithic flints have been recorded within the site. During an excavation at the William Edwards School 1km south of the site residual flints of Mesolithic and Neolithic date were recorded.
- 1.4.4 **Neolithic and early Bronze Age.** No certain Neolithic or early Bronze Age features or finds have been recorded within 1km of the site.
- 1.4.5 A cropmark possibly representing a large sub-circular enclosure 45m across and with opposing entrances is located c 2km north-west of the site, and if archaeological, this might well represent a late Neolithic henge monument. During the Hordon to Barking Gas Pipeline watching brief a shallow pit was recorded just north of this enclosure, which contained cremated bones of a mature/older adult female. There were no finds, but this could date from the later Neolithic or Bronze Age.
- 1.4.6 Elsewhere, the cropmarks of two parallel lines with a rounded terminal were identified 0.8km south-west of the site. This feature may have been a long-barrow or long mortuary enclosure of early or middle Neolithic date.
- 1.4.7 A ring ditch was also recorded 0.3km south of the site on the slopes of the Mar Dyke valley. This feature is 32m diameter and may represent the site of a ploughed out Bronze Age barrow.
- 1.4.8 **Later Bronze Age and Iron Age.** A ditch containing late Bronze Age finds was found 2km to the north-west of the site during the Hordon to Barking gas pipeline. This ditch was on a SW-NE alignment and was parallel to, and 40m north of, the existing field boundary. The ditch contained a relatively large quantity of burnt flint and three sherds of flint-gritted pottery, probably of late Bronze Age date. A second ditch on a parallel alignment produced a single sherd of late Bronze Age pottery along with 19th-20th century pottery. These ditches, which follow the downward slope of the topography, may conceivably indicate survival of ancient field systems, or may have cut through late Bronze Age features on the slopes of the Mar Dyke Valley.
- 1.4.9 Two rectilinear cropmark enclosures, one only partially visible, and a system of linear boundaries probably representing a field system have also been identified c 2km to the north of the site. Although currently undated, these may be of later prehistoric date, or alternatively may be Roman (see below).
- 1.4.10 The cropmark of a long curving ditch following an irregular course was recorded as part of the aerial mapping survey c 1km to the north of the site. This defines the western edge of a promontory and follows the topography of an area of higher ground. This feature can also be seen as an earthwork on LiDAR imagery, and it is therefore possible that a bank and a ditch may be present at this location. Late Iron Age pottery was found nearby on the edge of this promontory during the Hordon to Barking gas pipeline. It is possible that that the bank and ditch are of later

prehistoric date and the siting of it may suggest a defensive site. Alternatively, these features may represent a medieval or post-medieval field boundary, although it differs in character to the regular north-south post-medieval field boundaries just to the east.

- 1.4.11 On the southern edge of the Mar Dyke valley the scheduled Orsett cropmark complex (1002134) is located on the gravel terrace 0.4km south of the site. The main concentration of enclosures, ring ditches (probable prehistoric round house gullies), trackways and field systems are located in the northern part of the monument. Recent evaluation of these within Land Parcel 22 has confirmed that the complex is a mixture of late Bronze Age, early, middle and late Iron Age and Roman features (OCA 2020a). A small probable ring ditch on the west edge of Land Parcel 22 some 600m south of the site produced struck flints of later Bronze Age character, and much of a late Bronze Age vessel was recovered from a pit elsewhere within the complex.
- 1.4.12 In 1979 the southern part of the Orsett (Grey Goose Farm) Cropmark Complex was excavated during alterations to the A13, and several late Bronze Age to early Iron Age features, comprising one large and three small pits, postholes and a gully. These features were mostly located in the A1089 loop junction just north of the A13. The A13 investigations also found that some of the 'pits' were of geological origin, and the recent evaluations have confirmed that most of the discrete cropmarks are geological, although one pit alignment that continues as a ditch appears to be archaeological.
- 1.4.13 Two possible prehistoric cropmark enclosures have been identified east of the Orsett scheduled complex, and the site of a scheduled probable late Bronze Age enclosure (1009287) lies some 950m south-east of the site. To the west of the Orsett cropmark complex and 0.8km south-west of the site, an excavation at William Edwards school revealed late Bronze Age and early Iron Age settlement.
- 1.4.14 Bronze Age and Iron Age pottery was recovered from a mound c 1km north-west of the site. This mound may have been one of three Roman barrows once present around South Ockendon Old Hall. Two sherds of Iron Age pottery were also found during the excavation of the Roman scheduled barrow (1019106) located c 2km north-west of the site. The Roman barrows may have truncated Bronze Age or Iron Age features during their construction.
- 1.4.15 In 1966, 13 Bronze Age weights were found in a clay pit 0.8km west of the site. The exact purpose of these weights is unknown, but they may have been roof weights or loom weights. These finds were recorded in the vicinity of the cropmarks of a circular feature. The feature was recorded by the HER as a ploughed-out mound, but it is possible this may have been a domestic Bronze Age enclosure.
- 1.4.16 A number of cropmarks have been recorded on the area of higher ground to the north-west of the site. This includes a trackway and linear features north-west of South Ockendon Hall, a ring ditch and a number of pits 0.5km south of the site, ring ditches and a possible mound located c 2km north-west of the site and further ring ditches and rectilinear features 1km

south of the site. It is likely that some of these features are later prehistoric or Roman in date.

- 1.4.17 **The Roman period.** A scheduled burial mound (1019106) lies adjacent to, and just west of, the site on the high ground of the terrace edge on the western side of the Mar Dyke river valley, c 2km to the north-west of the site. In 1957 a trench through this barrow found 17 sherds of Roman pottery, although the central burial was not disturbed. This barrow may have been one of three spaced a similar distance apart. A second barrow was located c 400m south of the scheduled barrow, and was excavated prior to removal, the finds being dated to the late second century AD. A third barrow is also documented, though it was the first to be destroyed and its exact location is now unknown. An east-west trackway and other linear features that may be Roman in date were identified north of South Ockendon Hall by the aerial mapping survey.
- 1.4.18 A possible Roman cemetery was excavated somewhere to the north of the site in the 19th century but the exact location of this discovery is unknown, as noted above. The records suggest that in 1858 farm laborers found Roman pottery, animal bones and charcoal within shallow pits of black earth 3-12m diameter wide in a field within the Mar Dyke valley. This site extended for 2.4 hectares. A number of these pits contained parts of vessels and were located equidistant from one another. The absence of human bones may simply be due to effective cremation of the remains, but the large size of the features described makes it unlikely that these represent cremation burials, though they might indicate pyre sites. On balance, the 'urn sherds' reported may simply represent domestic pottery. One of the fields in which the remains were found in was called 'Ruin Field' and so it is possible that these features may have been part of a settlement that contained one or more buildings. The tithe maps for North Ockendon, South Ockendon, Bulphan and Orsett were checked for references to 'Ruin Field' but none was found.
- 1.4.19 Two rectilinear enclosures have been identified as cropmarks c 2km to the north of the site. One had an uncertain relationship with part of a field system to the south and was possibly cut by it. The two parallel ditches running WSW-ESE run between two existing field boundaries, so may be post-medieval field boundaries. These enclosures are located on slightly higher ground just above the floodplain. Given their morphology, and their proximity to the possible Roman settlement and/or cemetery, these enclosures may be of Roman (or later prehistoric) date.
- 1.4.20 The Orsett cropmark complex, located 0.4km south of the site, includes evidence for Roman activity as demonstrated in the recent evaluation (OCA 2020a). A cropmark site to the west at Stifford Clays-Primrose Island and 0.9km south-west of the site was excavated in the 1960s and 1970s and revealed a farmstead that was in use from the late Iron Age to the late Roman period with enclosures, ditches, pits, cremations and a corn drying oven. Another Roman enclosure site was also identified close to the Orsett cropmark complex, on the edge of the river terrace, and 0.8km south-east of the site. Roman finds have also been recorded on the terrace. These sites are aligned along the north edge of the gravel terrace

and may well have been linked by tracks or a road to Roman settlements around Orsett Cock further east, close to a Roman road.

- 1.4.21 Roman finds have been recorded to the west and north-east of the site. These include a coin of Marcus Aurelius (AD 161-180) and sherds of Roman pottery of mid-1st to mid-2nd century AD date found whilst stripping the topsoil during an excavation at South Ockendon Hospital.
- 1.4.22 **The medieval period.** No Saxon features or finds have been recorded within the site, and only limited evidence of Saxon activity has been found in the area surrounding it.
- 1.4.23 A dense pattern of cropmarks of varying size and shape are dispersed across the Orsett Cropmark Complex located 0.4km south of the site (1002134). The evaluation of Land Parcels 21 and 22 demonstrated that these are of natural origin and do not represent Saxon sunken-featured buildings as has previously been suggested (OCA 2020a and 2020b). Excavations directly to the south of the monument and 0.9km south of the site also indicated that features identified as pits by cropmark interpretation were primarily of natural origin. Saxon artefacts were however recorded in a few features, and a late Saxon baked clay loom-weight was recovered from one feature.
- 1.4.24 Documentary evidence suggests that this area was occupied during the Saxon period. During the late Saxon period the site and its surroundings was very likely part of the manorial estate of North and South Ockendon and also the manor of Orsett. The Domesday survey notes that North and South Ockendon was very large for the period with 90 households. Orsett was also large with 61 householders. These three settlements included entries for plough teams, pigs and sheep indicating a mixed agrarian economy. The division between these manors may have later formed the later medieval parish boundaries. The division boundary between the parishes of South Ockendon and Orsett is the Mar Dyke river. The division between South Ockendon and North Ockendon is more arbitrary and runs along field boundaries to the south of Fen Lane and drainage ditches to the north-east of the site.
- 1.4.25 The roads within this part of the scheme appear to have a roughly NNW-SSE and east-west alignment and this could relate to the formation of the parishes or the use of more ancient droveways. The medieval road network is probably much the same as is shown on the OS First edition of 1805 (not illustrated), as the area remained undeveloped into the 20th century. This map shows the north-south road (North Lane) from Puddle Dock to North and South Ockendon (now the B186), which is just west of the site.
- 1.4.26 **South Ockendon.** The nucleated settlement of South Ockendon was likely to have been located around the Church of St Nicholas and farmsteads scattered throughout the parish.
- 1.4.27 A medieval moated manor was located at South Ockendon Hall, which is now scheduled (1002155). The manor, c 2km north-west of the site, was known as 'Bruyns' and was certainly established by the 12th century but may have late Saxon origins. This manor house may have been rebuilt

several times during the post-medieval period. The moated site does not have any remaining structures internally except part of a medieval gatehouse. It is likely that medieval and post-medieval remains may be located below ground here.

- 1.4.28 This manor was split in the early 16th century and the manor of Groves was created to the north (see below). It is possible that there were water management ditches associated with the moat, though these are unlikely to extend into the site. A possible watermill, which was later replaced by a windmill, was located on the south side of the moat. This is thought to be post-medieval in date, but it is possible the watermill may have been medieval in date and contemporary with the medieval moat. This would have required an extensive water management system of drainage ditches, leats and sluice gates which may have extend into the area of the site. It seems plausible that the moat and possible watermill were fed by a spring line on the terrace since the Mar Dyke river is located downslope to the east.
- 1.4.29 It is possible that there was a medieval settlement located around the area of the moated manor, which may extend eastwards, though as far as the site. Cropmarks have been also identified 400m north-west of the moated manor house. These include rectangular enclosures, linear features and pits. In addition, an east-west trackway was identified by the aerial survey to the north-west of the hall along with a rectangular enclosure. It is possible this track could be medieval or earlier in date. Further linear features have been recorded as cropmarks c 2km west of the site. It is possible the enclosures and linear features could define stock enclosures and field systems associated with the manor. Alternatively, these features may of post- medieval date and associated with the later manor house.
- 1.4.30 **Orsett.** The site is located at the western extent of the manor and later parish of Orsett. The site of Bishop Bonners Palace is scheduled (1111592) and located 900m south-east of the scheme on the north edge of Orsett. This ringwork and bailey earthwork belonged to the Bishops of London during the medieval period. The later medieval settlement of Orsett was situated south of Bishop Bonners Palace around the Church of St Giles and All Saints (1147049). The Church of St Giles and All Saints located 1.4km south-east of the site has elements of architecture dating to the 12th century with extensive 14th and 15th century alterations. The later medieval settlement of Orsett was located c 1.1km south-east of the site. The hamlet of Baker Street, west of Orsett, and 800m south of the site may have been founded in the later medieval period.
- 1.4.31 The cropmarks of a possible medieval moated site were identified on the slopes of the valley c 150m north of Land Parcel 48B. Several other possible medieval moated sites have been identified as cropmarks just east of the site and within the parish of Orsett. This includes the cropmarks of two sub-rectangular enclosures jointed by a wide ditch located 600m north-east of the site. This could indicate the site of a double medieval moated site. An additional ditch is located just north of the easterly ditch. Another possible moat was recorded nearby but the

HER recorded this as destroyed so it may be on the site of a modern reservoir.

- 1.4.32 A number of possible medieval or post-medieval field boundaries were identified by the aerial mapping survey close to the site and within the parish of Orsett.
- 1.4.33 **Post-medieval period.** During the post-medieval period the road network in the area surrounding the site probably continued without significant change from that of the later medieval period. In relation to the principal estates of this period, the wider site, covered by WSI P, was located within the North Ockendon Hall estate, the Grove Barns estate, The South Ockendon Hall estate and the Orsett Hall estate. Prior to the later 20th century this area retained a largely rural character with dispersed farmsteads along tracks.
- 1.4.34 The relatively straight course of the Mar Dyke river on the 1691 estate map appears to match the modern route of the river, suggesting that it might have been canalized, or at least straightened, prior to 1691. Records of flooding of the river in the 18th century as far up as Stifford, however, may indicate that the canalization was later than this. Chapman and Andre's map of Essex of 1777 certainly shows the Mar Dyke following the canalized course, so it probably took place in the third quarter of the 18th century. Mar Dyke Fen is marked on this map east of the canalized course, bounded on the south side by a series of farms: unnamed, Jotts, unnamed (containing only one building), Hoblets, unnamed and Larkins. The same outline is shown on the 1805 Ordnance Survey First Series map of 1805, but this map usefully shows the promontory of high ground bounding the fen on the north.
- 1.4.35 A post-medieval mill was located c 2km north-west of the site, on the south side of the medieval moated manor of South Ockendon Hall (1002155). This mill was a post-medieval wind-powered smock mill which had been built on the site of a possible former watermill. The windmill was demolished in 1978. No trace of the watermill or windmill was found during a site visit in 2011. It is possible that the watermill or windmill could have been medieval in origin. As mentioned above, a series of medieval or post-medieval water management ditches may associated with this mill site.
- 1.4.36 The Orsett enclosure map of 1837 shows the extent of Mar Dyke Fen, which has not changed since 1805. The 1840 tithe map for Orsett shows that the southern part of the site had number of owners including the Baker family and William Wingfield of Orsett Hall. There are several field boundaries, which have been recorded by the aerial survey that lie c 500m west of the site. These field boundaries appear on the 1840 Orsett tithe map and are likely to be post-medieval in date, but some may be medieval in date.
- 1.4.37 The area just to the north of the site is still labelled as Orsett Fen on the tithe map and this area is blank on the map and also on the later 19th century OS maps, showing that this area was still too wet to make use of for arable or pastoral purposes.

- 1.4.38 The tithe maps and later 19th century OS maps indicate that there were five post-medieval farms located close to or within the site. These include Thrifts and Abrahams to the north-east of the site, Botney Farm (on the site of a formerly unnamed farm) on the northern boundary of the site, Hobletts Farm just to the north-east of the site, Old Barn to the north-west and Chantry Farm to the west. At least three of these farms originated in the later medieval period including Thrifts, Chantry Farm and Hobletts. All of these farms apart from Hobletts were demolished by the 1970s.
- 1.4.39 North of Botney Farm, and east of the modern field boundary and trackway running NNW from the former farm, there are rectilinear areas and lines showing as light patches within a palaeochannel of the Mar Dyke. These may possibly represent further buildings or areas of hard-standing associated with the farm or may have been caused by the temporary storage of materials very recently.
- 1.4.40 **Modern.** A number of 20th century military sites are located within the wider area but none of these are located within the site. These comprise a First World War landing site, a Second World War observation post, now destroyed, two heavy anti-aircraft gun sites and a Ground Controlled Interception Station.
- 1.4.41 In the late 20th century parts of the area surrounding the site were subjected to intensive quarrying. This removed historic field boundaries and probably buried archaeological remains, which may have been present in these areas.
- 1.4.42 **Undated features and cropmarks.** There are a number of undated features which have been recorded within the site. This includes the two rectilinear enclosures and linear features c 2km to the north of the site, which have been discussed above and may have either prehistoric or Roman origins. The possible ditch and bank at the edge of the promontory c 1km to the north of the site may be defensive in nature or may just be an unusually shaped field boundary above the floodplain. As discussed above, this may be of prehistoric origin or of medieval to post-medieval origin. A possible medieval moated site has also been recorded as a cropmark c 150m north-west of the site.

2 Project Aims

2.1 General aims

2.1.1 The general project aims of the project were as follows:

- i. To establish the presence or absence of archaeological remains along the line of the scheme, and the extent of any areas where remains appear likely to be absent;
- ii. In areas where archaeological remains are known or suspected, to clarify the reliability of the cropmark or geophysical survey evidence;
- iii. In areas where no archaeological remains are indicated by aerial or geophysical survey, to clarify whether this apparent absence of remains is genuine;
- iv. To determine the degree of complexity of any surviving horizontal or vertical stratigraphy, and in particular, to investigate areas where topography indicates the likelihood of deep deposit sequences for evidence of buried archaeological horizons and palaeo-environmental sequences;
- v. Where remains are present, to determine the period(s) represented, the extent, state of preservation and character of the archaeological remains;
- vi. To establish the range and state of preservation of archaeological artefacts, and through their recovery and examination, to establish the potential for information about the economy, status and contacts of past inhabitants of the scheme footprint;
- vii. To determine whether palaeo-environmental remains are preserved, and, where these are found, to determine their types (eg charred plant remains, waterlogged remains, molluscan remains), state of preservation and potential for environmental information. This will be achieved through the recovery of samples from sedimentary sequences and archaeological features suitable for assessment of a range of palaeoenvironmental remains (e.g. charred and waterlogged plant remains, charcoal, insects, pollen, diatoms, ostracods/foraminifera and molluscs) and scientific dating (e.g. radiocarbon and OSL dating);
- viii. To investigate and record the extent, character and chronology of the sedimentary sequences, in particular those immediately adjacent to and in floodplains, contained within palaeochannels or in dry valleys, and to use the data to refine existing geoarchaeological (predictive) deposit models.
- ix. To place any identified archaeological remains into their local and, where appropriate, regional or national context, and to assess the implications of any such discoveries for our current understanding of settlement and landscape change in the area, including an assessment of the associations of any remains with reference to the historic landscape;
- x. To provide sufficient information to enable the LTC archaeological advisor, in consultation with the Key Archaeological Stakeholders, to determine the significance of the archaeological assets identified within the land parcel;

- xi. To provide a report on the discoveries to inform the Environmental Statement (ES) supporting the Development Consent Order (DCO) and support the preparation of a further archaeological mitigation strategy for the Enabling Works and Construction phases of the scheme;
- xii. Following the DCO, to deposit the report in the public domain, and to generate an accessible and useable archive which will allow future research of the evidence to be undertaken.

2.2 Specific objectives

2.2.1 The specific project objectives, which were set out in WSI P and that are relevant to this site (Land Parcels 48 and 48C) were as follows:

- xiii. To conduct the programme of archaeological investigation within the general research parameters and objectives defined by the revised East of England Research Framework (Medlycott 2011);
- xiv. To establish the extent, depth and complexity of slope deposits, colluviation and alluviation, and to determine whether buried archaeological activity is preserved beneath or within them;
- xv. To identify areas along the edge of the former palaeochannels that may have been used for activity in the past, together with any islands or areas with only shallow seasonal inundation within the palaeochannels that may have had human activity, and if found, to characterise the type, date and complexity of activity upon and associated with them;
- xvi. To clarify the tidal limit of the former Mar Dyke river by examining sediment sequences in the southernmost parts of the Mar Dyke palaeochannels within the scheme for evidence of saltwater;
- xvii. To aim to relate any activity found on the valley slopes to activity on the higher ground, and in particular to the cropmark evidence;
- xviii. To clarify whether the cropmarks provide an accurate representation of the range, quantity and types of archaeological features present on the areas without alluvial covering within the site;
- xix. To look for evidence of domestic activity of earlier prehistoric date that may be associated with the possible monuments suspected from cropmarks to the west and south of the site;
- xx. To establish the presence or absence of the four medieval/post-medieval farmsteads which were located within the area of the site, one building of which may be extant at Hobletts Farm (2057); and,
- xxi. To establish the date of the possible medieval or post-medieval field boundaries that have been identified within the eastern and southern part of the site.

3 Methodology

3.1 Constraints

- 3.1.1 Several constraints limited the area of the land parcel available for trial trenching (OA 2021, fig. 8). These comprised a High-Pressure gas pipeline, aligned NE-SW, which lies within the southern third of Land Parcel 48B and an irrigation pipeline, aligned ENE-WSW, which lies centrally within Land Parcel 48B. An unexploded ordnance (UXO) survey also highlighted that parts of Land Parcel 48B, in the north-west and south of the site, present a moderate potential for the presence of UXO. An unexploded bomb is mapped in the north-west corner of Land Parcel 48C and three high explosive bombs were also recorded to the north of Land Parcel 48C. The remainder of the site was classified as having a low potential for the presence of UXO. Great crested newts are present in almost all of the ponds within the Mar Dyke valley. Where necessary the appropriate licence was acquired from Natural England and appropriate measures for their protection put in place.
- 3.1.2 These limitations were taken into account when designing the detailed trench layout. No significant alterations to the layout were implemented during the fieldwork phase.
- 3.1.3 In accordance with the safe system of work established by Balfour Beatty, excavation was ceased at a maximum depth of 1m below ground level. Several of the larger features were not excavated to full depth within this constraint, although there was an option to widen trenches to allow deeper excavation where it was deemed appropriate to inform the evaluation results.

3.2 Methodology for the evaluation

- 3.2.1 The total area of Land Parcels 48B and 48C was 29.71ha, and the area available for investigation excluding areas of services was 27.00ha. The archaeological trial trenching comprised a total of 157 trenches, each measuring 30m x 2m. This represents a 3.5% sample of the area available for trenching. The location of the trenches is shown on Figure 2.
- 3.2.2 The trench design was developed to target cropmark features identified by the aerial investigation and mapping report (Place Services, 2019), anomalies identified in the geophysical survey (Magnitude Surveys 2020) and otherwise to provide even coverage of the blank areas. Several trenches were not laid out on a standard grid but adjusted slightly to account for an exclusion zone associated with the high-pressure gas pipeline in the southern third of Land Parcel 48B. Trenches were spaced to avoid any large gaps, and to cover all underlying geologies. A proportion of the trenches have been aligned at right angles to the orientation of the valley slope (Fig. 2).
- 3.2.3 Trenches 174, 175 and 179 were slightly repositioned to account for a revision to the location of the irrigation pipeline in the central part of Land Parcel 48B. Trench 162 was also moved away from the footprint of the

site compound and relocated into the space where the former irrigation pipeline exclusion zone had been defined prior to its revision.

- 3.2.4 All trenches were located using a Global Positioning System (GPS) prior to machine excavation. All trenches were excavated using a tracked excavator fitted with a toothless bucket under constant archaeological supervision.
- 3.2.5 Revealed features were hand cleaned where appropriate and sampled by hand excavation. They were recorded as outlined with the approved WSI. All finds were bagged by context throughout the evaluation and were recovered for further investigation.

4 Results

4.1 Introduction and presentation of results

- 4.1.1 The results of the evaluation are presented below and include a stratigraphic description of the trenches that contained archaeological remains. The full details of all trenches with dimensions and depths of all deposits, and a summary of the finds, can be found in Appendix A. Finds data are tabulated and reported upon in Appendix B, and environmental materials in Appendix C. A geoarchaeological report is presented in Appendix D.
- 4.1.2 Context numbers reflect the trench numbers unless otherwise stated. The first numerals of a context number reflect the trench number whilst allowing for a maximum range of 100 individual records for any one trench. For example, pit 102 is a cut within Trench 1, while ditch 304 is a cut within Trench 3.
- 4.1.3 An overview of the results for the site is shown on Figure 2, and slightly more detailed views of the north and south halves of Land Parcel 48B, and of Land Parcel 48C, in Figures 3-5. Further detailed plans and sections of the trenches that contained archaeological features are shown on Figures 6-36.
- 4.1.4 In the following narrative the features are described by area, each area covering a group of plan figures, and the plans are followed by a single A3 section figure.

4.2 General soils and ground conditions

- 4.2.1 The ploughsoil typically measured between 0.2m and 0.45m thick, the variation in depth resulting from mixed agricultural activities across the site. Across much of the site this overlay a subsoil layer, measuring between 0.08m and up to 0.3m thick. Slightly thicker deposits of subsoil measuring up to 0.36m thick were also recorded in several trenches across the middle and southern part of Land Parcel 48B. Possible alluvial deposits were also recorded in Trenches 136 and 146 in the north of Land Parcel 48B, but nowhere else within the site (Appendix D). The underlying natural geology comprised London clay formation across the whole site and the superficial geology comprised a deposit of head clay. No colluvial sequences were found on the site, with the possible exception of a deposit in Trench 122 measuring 0.27m thick, which was overlain by ploughsoil and in turn overlay a 0.45m thick deposit of weathered London clay. No palaeochannels were thought to be present within the site and none were identified in any of the trenches.
- 4.2.2 The fieldwork was accompanied predominantly by reasonably fine weather throughout with no periods of rain sufficient to cause any of the trenches to flood. Most of the deeper features remained dry throughout the evaluation and there was no measurable impact associated with prevailing weather conditions. Where present, archaeological features were easily identifiable against the natural geology, and the initial

investigation of features of natural origin provided a solid benchmark for distinguishing these from archaeological features subsequently without the need for excavation.

4.3 General distribution of archaeological deposits

- 4.3.1 Archaeological features were revealed in 58 of the trenches: 127, 129, 131-134, 136, 140, 142-144, 148, 162-163, 168, 170, 171, 174-175, 178-182, 184-185, 187-188, 190, 192, 194, 196-197, 199, 203-204, 211, 213-214, 217-219, 222, 226, 230-231, 233-235, 239, 250, 253-255, 259, 265-267, 273 and 276.
- 4.3.2 The predominant concentration of archaeological features lay within the southern half of Land Parcel 48B. Features comprised a combination of enclosure and field boundary ditches, pits and one posthole, along with several tree-throw holes and other natural features such as periglacial cracks. Where features were dateable, these were of late Iron Age / early Roman or Roman origin.
- 4.3.3 All other trenches were devoid of archaeology or contained only natural features. Whilst several of the natural features were investigated, specifically in Trenches 130, 136, 142, 212 and 274, the majority, found in Trenches 180, 191, 198, 205, 209, 215, 219, 226, 229, 241, 249, 253, 256, 257, 258, 265, 269, 270, 276 and 277, were recorded in plan but were not excavated.

4.4 Trenches 127, 129, 130, 131-134, 136, 140, 142-144 and 148 (Fig. 3; Figs 6-12)

- 4.4.1 This group of trenches lay at the northern end of Land Parcel 48B (Fig. 3). The remains of six NNW-SSE aligned ditches, five of them quite substantial, were recorded: one in Trench 127 (Fig. 6, ditch 12703), one in Trench 140 (Fig. 10, ditch 14003) and three in Trench 144 (Fig. 11, ditches 14403, 14405 and 14408). A naturally occurring periglacial crack on a similar alignment was also inspected in Trench 142 (Fig. 10, feature 14203).
- 4.4.2 In **Trench 127** ditch 12703 had a moderately sloped, rounded profile and measured 1.76m wide by 0.5m deep with a single fill, from which no finds were recovered (Fig. 12, Plate 1).
- 4.4.3 In **Trench 140** ditch 14003 represented the remains of a former field boundary of probable post-medieval origin, which is evident on historic mapping and as a cropmark (Figs 3 and 10). A modern ceramic field drain was identified within this ditch, following which excavation ceased.
- 4.4.4 The three ditches in **Trench 144** had steep-sided, flattish-based profiles and measured between 0.96-1.46m wide and up to 0.77m deep (Fig. 12). Ditches 14405 and 14408 each contained two fills, but no finds were recovered from any of these. Ditch 14403, however, was only 0.19m deep and had a single fill, from which no finds were recovered (Plate 2).
- 4.4.5 It is possible that ditch 13205 in Trench 132 to the north, which was also on a NNW-SSE alignment, was a continuation of ditch 14405, as this ditch was around 1m wide and was not bottomed at 0.5m deep, but the

distance between Trenches 132 and 144 means that this remains tentative. No continuations of any of the three ditches in Trench 144 were seen in Trench 156 to the south.

- 4.4.6 **Trench 132** contained four ditches in all. Ditch 13205 was crossed by ditch 13207, one of three parallel ditches on an ENE-WSW alignment, the others 12.5 and 15.5m further south-east in Trench 132 (Fig. 9). Ditch 13207 was 0.9m wide and 0.18m deep with concave sides and a flat base and had a single fill (13208) from which one piece of animal bone was recovered. Ditch 13209 lay south of 13203, and these ditches were narrower, were respectively 0.6m and 0.4m wide and 0.13m and 0.10m deep, with moderately sloping sides and rounded bases (Fig. 12, Plate 4, ditch 13203). Neither had any finds in their single fills.
- 4.4.7 It is possible that all three ditches were part of one contemporary field system, but no trace of either ditch was seen in Trench 131 to the west. Ditches 12904 and 12906 were on the projected line of ditch 13207, but were both significantly deeper than it, and the alignment of the ditches in 129 was slightly different. Due to the distance between these trenches, matching these ditches must remain speculative.
- 4.4.8 A recut ditch on a NE-SW alignment was recorded in **Trench 129** (Fig. 8). Ditch 12904 was substantial, measuring 2.44m wide and 0.45m deep with moderately sloped sides and a rounded base. No finds were recovered from its single deliberately backfilled deposit. This was cut by U-shaped ditch 12906, which measured 0.77m wide and 0.6m deep. With the exception of an iron belt buckle fragment of probable post-medieval or modern origin, no finds were recovered from its single deliberately backfilled deposit (Fig. 12, Plate 3).
- 4.4.9 Two further ditches on a broadly ENE-WSW alignment were found. In **Trench 134** (Fig. 7, ditch 13403) the ditch curved slightly within the trench, was 0.56m wide and survived 0.10m deep and had concave sides and base. Its single fill did not contain finds.
- 4.4.10 Machining of **Trench 136** and geoarchaeological inspection of the soil sequence identified a possible alluvial origin for the subsoil deposit 0.26m thick that lay beneath the topsoil (Section 13602, Plate 27). Below this a linear feature was found (Fig. 8, ditch 13606). Feature 13606 was linear, but when excavated appeared to be undercutting the natural at the base, and was reinterpreted as a naturally occurring periglacial crack. There were, however, three fills in this feature, and only the lowest (13607) actually undercut the natural; while the middle fill (13608) was sterile, the top fill (13609) contained a Mesolithic microlith, so it is possible that there was a ditch overlying the periglacial crack at this point.
- 4.4.11 The remains of three ditches aligned north-south were recorded, one in Trench 131 (Fig. 9, ditch 13103), one in Trench 143 (Fig. 11, ditch 14303) and one in Trenches 142 and 148 (Fig. 10, ditch 14206 continuing as 14803 c 30m to the south). Ditch 14206 was not excavated, but ditch 14803 was. Each of the ditches had similar moderate to steep-sided, flat-based profiles, although the excavated section through ditch terminal 14303 exposed only half its profile (Fig. 12, Plate 5). All three ditches measured 0.7-0.98m wide; ditches 13103 (Plate 6) and 14803 were 0.4-

0.5m deep, while ditch terminal 14303 was 0.24m deep. Single fills were recorded in each ditch and the fills of ditches 13103 and 14803 could perhaps represent deliberate backfill. No finds were recovered. These ditches do not correspond to historic field boundaries or other evident cropmarks but are likely to represent the remains of agricultural cultivation practices.

- 4.4.12 Four pits, one posthole and one tree-throw hole were also recorded in the northernmost part of Land Parcel 48B. In **Trench 127** (Fig. 6) tree-throw hole 12705 measured 1.62m wide and 0.34m deep with moderately sloped sides and an irregular base (Fig. 12). No finds were recovered from its single fill.
- 4.4.13 **Trench 129** exposed 0.6m of an elongated pit or ditch terminal 12902 only 1m north of ditches 12904 and 12906 (Fig. 7). This was 0.36m wide by only 0.04m deep with sloping sides and a rounded base (Fig. 12). No finds were recovered from its single fill.
- 4.4.14 **Trench 133** exposed two pits (13303 and 13307) and one posthole (13305), all forming a NW-SE line (Fig. 6). Pit 13303 and posthole 13305 were only just over 2m apart, and were of similar size, measuring 0.34-0.37m long and only 0.05-0.07m deep with sloping sides and a rounded base (Fig. 12, Plate 7). No finds were recovered from either of their single fills. Sub-circular pit 13307 measured 0.93m in diameter by only 0.08m deep and had a quite irregular profile, steeply-sloped on its north-west side, much less so on its south-east side, with a flattish base (Fig. 12, Plate 8). No finds were recovered from its fill, although it did contain charcoal. Environmental sample <S.6> yielded both frequent charcoal and a possible free-threshing wheat grain. Trench 136 exposed part of a sub-circular pit 13603 (Fig. 8). It was steeply sloped on both sides (more irregular on its north-west side) and had a flattish base (Fig. 12). No finds were recovered from either of its two fills.
- 4.4.15 A natural feature was investigated in **Trench 130** and interpreted as a periglacial crack (13002). No finds were recovered from its multiple naturally accumulated fills.

4.5 Trenches 162, 163, 171, 178 and 179 (Fig. 3; Figs 13, 14 and 20)

- 4.5.1 This group of trenches lay in the northern part of Land Parcel 48B, and south of an ENE-WSW cropmark division separating them from the trenches at the northern end of the land parcel described above (Fig. 3).
- 4.5.2 The remains of eight ditches on varying alignments were found in this group of trenches. 17103, 17105, 17803, 17903 and 17906). None contained datable artefacts. This is speculative, based on the broadly NNW-SSE and ENE-WSW alignment of several examples, which accord well with cropmark evidence, and the evidence of historic mapping; none yielded datable finds. The other examples, aligned NE-SW, are also probably associated with cultivation activities, perhaps within these putative field systems, but of possible earlier origin (see below).

- 4.5.3 **Trench 162** revealed two ditches (Fig. 13, ditches 16203 and 16207). Ditch 16203 crossed the western end of the trench on a NE-SW alignment, measured 1.62m at its widest point and was 0.4m deep. It contained three fills, which appear to have naturally accumulated (Fig. 20), but no finds.
- 4.5.4 Ditch 16207 lay east of ditch 16203, and was aligned broadly NNW-SSE. It measured 0.8m wide by 0.18m deep, had steeply-sloped sides and a rounded base and contained a single naturally accumulated fill (Fig. 20), again without finds.
- 4.5.5 **Trench 163** was crossed at the northern end by ditch 16303 running ENE-WSW (Fig. 13). This ditch lay only 3m south of cropmark and historic mapping depictions of a former field boundary on the same alignment, and it is likely that this ditch either corresponds to the cropmark, or marked another phase of the same boundary (Fig. 3). It had steeply-sloped sides, a flat base and measured 0.99m wide by 0.35m deep (Fig. 20, Plate 9). Two small fragments of undatable Ceramic Building Material (CBM) were recovered from its single naturally accumulated fill.
- 4.5.6 **Trench 171** exposed two phases of a sinuous ditch on a broadly NNE-SSW alignment crossing the centre of the trench (Fig. 14). Ditch 17105 is the earlier of the two and its full width was not exposed within the trench. The surviving part of the ditch was >1m wide and was 0.25m deep (Fig. 20). Its single naturally accumulated fill contained frequent charcoal.
- 4.5.7 Ditch 17105 was cut on the east side by ditch 17103, which was 0.68m wide by 0.26m deep with steeply sloped sides and a broadly V-shaped base. There were no finds from the fill.
- 4.5.8 **Trench 178** contained a single ditch at the western end (Fig. 14, ditch 17803). It was aligned NNW-SSE, measured 1.37m wide and 0.25m deep and had sloping sides and a flattish, slightly irregular base (Fig. 20). The ditch contained a single naturally accumulated fill that was devoid of finds. The projected continuation of ditch 17105/17103 was in line with ditch 17803, and although the alignments of the two ditches differed, since ditch 17105/17103 was somewhat sinuous, it is possible that the two were parts of a single boundary. It is however equally possible that ditch 17803 continued south as ditch 19203 (see below). In Trench 184 further south (Fig. 17) ditch 18403 was also on the same line, but again on a NNW-SSE alignment. It is possible either that this boundary was sinuous all along its length, and continued through all three trenches, or that these ditches, which also vary in width, are unconnected.
- 4.5.9 **Trench 179** contained two ditches (Fig. 14, ditches 17903 and 17906). Ditch 17903 was aligned more ENE-WSW than east-west, and ran across the north-west end of the trench. It measured 0.99m wide by at least 0.42m deep, but was not bottomed due to water ingress. The ditch sides were steeply sloping and slightly irregular, being almost vertical in part on the north-west side. Two naturally accumulated fills were exposed (Fig. 20), neither containing finds. Ditch 17903 was very similar to ditch 16303 c 140m to the north-west, and probably also represents a former field boundary.

4.5.10 Ditch 17906 was orientated just east of north-south and measured 1.17m wide by 0.37m deep. It had steeply sloping sides and an almost V-shaped base, and contained a single naturally accumulated fill (Fig. 20) but no finds. No continuation of this ditch was seen in Trench 186 to the south (Fig. 3). This ditch is very similar morphologically to ditch 17103, which lies 30m to the north-west, and may have been associated with it.

4.6 Trenches 168, 170, 174, 175, 180, 181 and 182 (Fig. 3; Figs 14-16 and 20)

4.6.1 This group of trenches also lay south of the ENE-WSW cropmark subdivision within the northern part of Land Parcel 48B, and east of the trenches described above. The remains of six ditches were recorded on an approximately east-west alignment, one in Trench 168 (Fig. 15, ditch 16803), one in Trench 174 (Fig. 14, ditch 17403), one in Trench 180 (Fig. 14, ditch 18003), two in Trench 181 (Fig. 16 ditches 18103 and 18107, and a continuation of 18103 in Trench 182, where it was numbered 18203).

4.6.2 In **Trench 168** ditch 16803 was orientated broadly east-west and crossed the middle of the trench. It measured 0.8m wide by 0.43m deep, had steeply sloping sides and a rounded base, and contained two naturally accumulated fills, neither of which contained finds (Fig. 20, Plate 10). No continuation of this ditch was seen in Trench 167 to the west, but the continuation may lie just north of this trench.

4.6.3 **Trench 174** revealed ditch 17403 running WNW-ESE at the north-east end of Trench 174 (Fig. 16). It measured 1.1m wide by 0.59m deep, had steeply sloping, slightly irregular sides and a flat base, and contained three fills (Fig. 20, Plate 11). These fills had probably naturally accumulated and whilst no finds were recovered from the primary or secondary fills, two small abraded Roman sherds were recovered from its final fill.

4.6.4 In **Trench 180**, approximately 80m south-west of Trench 174, a ditch on a WNW-ESE alignment crossed the west end of the trench (Fig. 14, ditch 17403). It measured 0.96m wide by 0.49m deep, had almost vertical sides and a slightly rounded, flattish base and contained a single, possibly deliberately deposited fill, from which no finds were recovered (Fig. 20).

4.6.5 **Trench 181** lay east of Trench 180, and contained two ditches (Fig. 16, ditches 18103 and 18107). Ditches 18103 and 18107 lay c 50m to the east of ditch 18003, and were parallel to one another, with a c 13m gap between them. Ditch 18103 measured 1.1m wide and 1m deep, with steeply sloping sides and a flat base; ditch 18107 was 1.6m wide and 0.7m deep, again with steeply sloping sides but with a more V-shaped profile and a much narrower flat base (Fig. 20, Plate 12, 13). Each ditch contained a single fill, which may have been deliberately deposited. Five small sherds of abraded middle to late Roman pottery were recovered from fill 18104 of ditch 18103 and three sherds of late Iron Age - early Roman and Roman sherds from fill 18108 of ditch 18107. A residual Mesolithic microlith was also recovered from fill 18108.

- 4.6.6 Ditch 18103 continued across the centre of Trench 182, and here it was of varying width in plan, but was not investigated further. No continuation of this ditch was found yet further east in Trench 183.
- 4.6.7 On the basis of the pottery from the ditches in Trench 181, it is possible that all of these similarly-aligned ditches represent evidence principally of Roman agricultural activity and are likely to comprise elements of a network of cultivation or drainage ditches. It is possible that they may be contemporary with undated examples that are aligned broadly perpendicular to these on a NE-SW alignment in Trenches 162, 171 and 179, though this is somewhat speculative.
- 4.6.8 **Trench 170** contained a tree-throw hole (Fig. 15, feature 17003) of irregular sub-oval shape in plan measuring 1.0-1.8m by 0.7-0.83m and 0.22m deep. No finds were recovered from the single fill of tree-throw hole 17003.
- 4.6.9 **Trench 175** also contained a tree-throw hole (Fig. 16, feature 17503) of irregular sub-oval shape in plan, and of very similar size. No finds were recovered from the two fills of tree-throw hole 17503, although the latter exhibited signs of burning (Fig. 20, Plate 14). Abundant charcoal was also recovered from environmental sample S.5 taken from 17504, the fill of 17503, along with a small quantity of very abraded charred cereal grain.
- 4.6.10 **Trench 181** partially exposed a pit (Fig. 16, pit 18105), and this measured 1.15m by 0.54m in plan and was 0.16m deep (Fig. 20). It had steeply sloped sides with a flat base and contained a single naturally accumulated fill from which no finds were recovered.

4.7 Trenches 184, 185, 187, 188, 190 and 192 (Fig. 4; Figs 17-20)

- 4.7.1 This group of trenches lay in the central portion of Land Parcel 48B, and south of Trenches 180-183 (Fig. 4).
- 4.7.2 Two similar ditches, in Trenches 184 and 192 respectively, lay on a similar NNW-SSE alignment to ditches 17803 and 16207 to the north and may also represent elements of the more recent, perhaps post-medieval agricultural landscape, though, as with the other examples no datable finds were recovered (Fig. 17, 18403 and 19203).
- 4.7.3 In **Trench 184** ditch 18403 measured 0.75m wide by 0.41m deep and had steeply sloping sides and a rounded base, very similar in morphology to ditch 16207 to the north (Fig. 20, Plate 15). It contained a single naturally accumulated fill.
- 4.7.4 In **Trench 192** to the south-east ditch 19203 measured 0.77m wide by 0.16m deep and had steeply sloped sides with a flat base (Fig. 20, Plate 16). Its morphology was very similar to ditch 17803 and its alignment sufficiently close to consider the two parts of the same probable post-medieval field boundary.
- 4.7.5 **Trench 185** contained a single ditch aligned NNE-SSW at the southern end (Fig. 17, 18503). It measured 0.93m wide by 0.3m deep and had steeply sloped sides with a rounded base (Fig. 20, Plate 17). There was only one fill, which did not contain finds. The projected line of this ditch

meets ditch 19203 to the south, but this ditch is on a different alignment, so this may be coincidental. From its alignment and morphology, it may possibly be associated chronologically with ditches on a similar alignment slightly further to the north, including 16203, 17103 and 17906, and probable Roman period cultivation ditches that lie on a NW-SE alignment.

- 4.7.6 The remains of four ditches were recorded on a broadly WNW-ESE alignment, two in Trench 187 (Fig. 18 ditches 18703 and 18707, one in Trench 188 (Fig. 18 ditch 18803) and one in Trench 190 (Fig. 19, ditch 19003).
- 4.7.7 In **Trench 187** ditch 18703 lay toward the north end of the trench. It had steeply sloping sides and a flat base, measured 1.08m wide by 0.42m deep and contained a naturally accumulated primary fill with a deliberately deposited secondary fill (Fig. 20, Plate 18). No finds were recovered from either.
- 4.7.8 Ditch 18707 lay approximately 7.5m to the south and though on a very similar alignment exhibited a quite different morphology. It had moderately sloping sides with an irregular base and measured 1.21m wide by 0.32m deep, and contained a naturally accumulated fill from which no finds were recovered (Fig. 20). Cut by ditch 18707 was ditch 18709, which was sinuous and aligned broadly north-south. It measured 0.43m wide and was only 0.12m deep, had a moderate slope on the west side and a flat base (Fig. 20). No finds were recovered from its single fill.
- 4.7.9 A further ditch was investigated in Trench 187 (Fig. 18). Ditch 18705 was aligned ENE-WSW, had steeply sloping sides with a rounded base and measured 0.85m wide by 0.42m deep (Fig. 20). No finds were recovered from its single naturally accumulated fill.
- 4.7.10 In **Trench 188** WNW-ESE ditch 18803 lay at the north-east end, and was 0.4-0.55m wide, but was not excavated. Its projected line passes just north of the end of Trench 187, and a similar distance from 18703 to that between 18703 and 18707, suggesting that all three ditches may have formed part of a contemporary system, probably also including ditches 18003, 18103 and 18203 to the north.
- 4.7.11 **Trench 190** contained a ditch towards its west end (Fig. 19, ditch 19003). It measured 1.5m wide and 0.45m deep and had steeply sloping sides, the upper part of its south side being more irregular, and a rounded base (Fig. 20). Without this irregularity or disturbance, it may originally have been morphologically similar to the other examples on the same alignment. There were two fills, a primary spill down the north side (19004) that was without finds, and the main fill (19005), also probably derived from natural silting, in which four sherds of abraded Roman pottery were found. If the Roman finds date this ditch, it is possible that the whole series of ditches on this alignment are of Roman date, which would also make ditch 18709 either earlier Roman or prehistoric. The sherds in ditch 19003 were, however, abraded, so may merely provide a *terminus post quem* for the ditch system.
- 4.7.12 A possible ditch or irregularly shaped pit was also investigated at the west end of Trench 190 (Fig. 19, 19006). It appeared to be broadly NE-SW

aligned though looked heavily disturbed at its north-east end though did not appear to cut or be cut by Roman period ditch 19003 (Figs 19 and 20). Where preserved it had steeply sloped sides with a flat base and measured 1.4m wide by 0.36m deep. No finds were recovered from either of its two naturally accumulated fills.

4.8 Trenches 194, 196, 197 and 199 (Fig. 4; Figs 18-21)

- 4.8.1 This group of trenches lay south and east of Trenches 187-188 in the central part of Land Parcel 48B. They contained an ill-defined irregular feature, a probable tree-throw hole and two pits.
- 4.8.2 **Trench 194** was crossed at the west end by an irregularly-shaped feature that was broadly aligned north-south but was not fully exposed (Fig. 18, 19403, 19603, 19703 and 19903). The excavated part measured 1.2m wide, and the feature was excavated to a depth of 0.44m, but was not bottomed (Fig. 20). The two exposed fills resulted from natural silting, and a single piece of animal bone was recovered from the interface between the earlier fill (19404) and the later fill (19405). No other finds were seen.
- 4.8.3 **Trench 196** contained one feature aligned NNW-SSE at the west end (Fig. 19, feature 19603). throw 19603 was elongated in plan along a broadly NNE-SSW alignment, and was 1.14m wide and 0.28m deep with a stepped profile and a curving base (Fig. 20). There were two fills, both the result of natural silting, the lower main fill overlain in the centre at the top by a second fill. No finds were recovered from either fill.
- 4.8.4 **Trench 197** contained a circular pit (Fig. 19 pit 19703) towards the north end of the trench. This was 0.74m in diameter and 0.2m deep, with steep sides and a flat base (Fig. 20). No finds were recovered from its naturally accumulated fill.
- 4.8.5 **Trench 199** lay south-west of Trench 194, and contained a large irregularly-shaped pit or possible tree-throw hole (Fig. 21, feature 19903). It measured 2.8m long by 1.8m wide and was 0.24m deep (Fig. 27). No finds were recovered from any of its three naturally accumulated fills, although there was evidence of *in situ* burning, which along with its morphology supports interpretation as a tree-throw hole. Environmental sample S.4 was taken from secondary fill 19905, and produced a moderately large quantity of charcoal.

4.9 Trenches 203, 204, 211, 212, 213 and 214 (Fig. 4; Figs 22, 23 and 27)

- 4.9.1 This group of trenches lay in the southern third of Land Parcel 48B, just south of an ENE-WSW linear cropmark that subdivided the land parcel, and north of the major service crossing the site (Fig. 4).
- 4.9.2 **Trench 203** contained an ENE-WSW ditch at the north end (Fig. 22, ditch 20303), which was on the same line as a former post-medieval field boundary (Fig. 4). Ditch 20303 had steeply sloping sides with a rounded base and measured 0.96m wide by 0.38m deep. It had a single naturally accumulated fill from which no finds were recovered (Fig. 27).

- 4.9.3 **Trench 211** contained a ditch that crossed the centre of the trench on a NNW-SSE alignment (Fig. 23, ditch 21103). This ditch was very wide, measuring 2.7m by 0.24 m deep, with shallow sloping sides and a flat base. No finds were recovered from its single naturally accumulated fill (Fig. 27). The very broad and shallow character of this feature is more like that of a medieval or post-medieval furrow than a ditch, but no similar parallel features were seen in the trenches, so this interpretation is unlikely. Feature 21103 was, however, also in line with a broad soilmark with irregular edges identified in Trenches 205 and 198 to the north. The soilmarks were interpreted as of natural origin, but an alternative possibility is that these, together with 21103, represent the remains of a hollow-way.
- 4.9.4 **Trench 213** contained a ditch at its west end that was also on a NNW-SSE alignment (Fig. 23, ditch 21307). This ditch had steeply sloping sides with a rounded base and measured 0.96m wide by 0.34m deep (Fig. 27). No finds were recovered from its single naturally accumulated fill. The ditch was very similar morphologically to ditch 20303, though aligned broadly perpendicular to that feature. Ditch 21307 was cut into a deposit (21309) thought to be a slightly mixed interface with the natural substrate, and also cut a short length of ditch 21305, only whose northern terminus lay within the trench (Fig. 23). Ditch 21305, like 21307, had steeply sloping sides and a rounded base (Fig. 27). It survived 0.66m wide and was 0.34m deep with a single naturally accumulated fill from which no finds were recovered. These features are likely to associated chronologically with those already discussed to the north.
- 4.9.5 **Trench 204** exposed part of two features towards the west end along its northern edge (Fig. 22, 20403 and 20405). The larger of these (20403), measured 2.85m wide and was 0.24m deep, and had sloping sides and a flat base (Fig. 27). No finds were recovered from its naturally accumulated fill. This feature may have been a tree-throw hole rather than a pit. Adjacent to its east side was feature 20405, which was 0.88m wide and 0.38m deep with steeply sloping sides and a flat base (Fig. 27). The profile of probable tree-throw 20405 was somewhat irregular, however and had a primary fill comprising a dense deposit of charcoal (20406). With the exception of a small quantity of charcoal recovered from environmental sample S.2, this fill and the two subsequent naturally accumulated fills of 20405 produced no finds. This could also represent the remains of a burnt-out tree-throw hole rather than a pit.
- 4.9.6 As well as ditch 21305, Trench 213 also contained a pit 10m further east (Fig. 23, 21303). Pit 21303 was oval, measuring 1.2m north-south by 1.04m east-west and 0.11m deep, and had steeply sloping sides and a flat base (Fig. 27). No finds were recovered from the single naturally accumulated fill.
- 4.9.7 **Trench 214** revealed a ditch on a NNE-SSW alignment towards the north end of the trench (Fig. 23, ditch 21403). This measured 0.64m wide and 0.42m deep, and unlike most of the ditches further north, had vertical sides and a flat base. No finds were recovered from its single fill.

Morphologically this is similar to a series of ditches on a similar alignment further south (see below).

4.10 Trenches 217, 218, 219, 222, 230, 233 and 250 (Fig. 4; Figs 24-7, 30 and 36)

- 4.10.1 This group of trenches lay at the southern end of Land Parcel 48B, south of the major service crossing this land parcel, and north of Green Lane (Fig. 4). Description of this area is divided into two, a group of NNE-SSW and north-south aligned ditches being described first, as they are likely to represent the remains of cultivation ditches associated with Roman period agricultural activity. This is followed by the description of the remaining ditches, which are on different alignments (see Section 4.11 below).
- 4.10.2 Eight ditches aligned NNE-SSW or north-south were found, one in Trench 217 (Fig. 24, ditch 21703), one in Trench 218 (Fig. 24, ditch 21803), one in Trench 219 (Fig. 24, ditch 21903), one in Trench 230 (Fig. 25, ditch 23005), two in Trench 233 (Fig. 26, ditches 23303 and 23305) and three in Trench 250 (Fig. 30, ditches 25003, 25005 and 25007).
- 4.10.3 In **Trench 217** ditch 21703 was 0.9m wide and at least 0.4m deep with near-vertical sides, but was not bottomed (Fig. 27, Plate 19). Two fills were exposed (21704 overlain by 21705), both deposited by natural silting, and a sherd of late Iron Age - early Roman
- 4.10.4 The ditch in **Trench 218** (Fig. 24, ditch 21803) had a different profile, being bowl-profiled with curving sides and base, and was 1.12m wide and 0.42m deep (Fig. 27, Plate 21). Its single fill (21804) appeared to have been deliberately deposited, and contained a single sherd of Roman pottery.
- 4.10.5 Unlike trenches 217 and 218, the ditch in **Trench 219** was aligned slightly west of north-south (Fig. 24, ditch 21903), but had the same vertical-sided and flat-bottomed profile in its lower part as 21703. Ditch 21903 measured 1.4m wide and 0.6m deep with a stepped profile, deeper on the east side, where the profile was vertical-sided and flat-bottomed. (Plate 22) The deeper part of the ditch was filled with one fill (21904), the wider and shallower cut with a second fill (21905). A sherd of Roman pottery was recovered from the lower fill, and a fragment of undated CBM from the upper fill. No trace of continuations of any of ditches 21703, 21803 or 21903 was seen in Trenches 222-224 or 229 to the south.
- 4.10.6 **Trench 230** contained two ditches, one on a NNE-SSW alignment, the other, which was further south, on an ENE-WSW alignment (Fig. 25, ditches 23005 and 23003 respectively) Ditch 23005 was 0.75m wide and 0.52m deep, with steeply sloping sides and a flat base (Fig. 27). It had a single fill that appeared to have been deposited deliberately, but which did not contain any finds. No continuation of this ditch was seen in Trenches 224 and 236 to the north-east and south-west respectively. Ditch 23003 is described in report section 4.11 below.
- 4.10.7 **Trench 233** contained three features (Fig. 26), including a ditch on a NNE-SSW alignment (23305) and another aligned slightly west of north-south (23303). Just west of 23303 was a much wider feature (23307).

Ditch 23305 was 0.77 wide and just under 0.6m deep with near vertical sides and a flat base, and had a single fill due to natural silting that did not produce any finds, but was very similar in size and profile to ditch 21403 and the lower part of ditch 21903. The projected line of ditch 23305 is broadly in line with ditch 25007 120m further south-west, but the distance is too great to regard this equivalence as anything other than highly tentative. Features 23303 and 23307 are described in report section 4.11 below.

- 4.10.8 **Trench 250** revealed three parallel ditches on a NNE-SSW alignment, fairly evenly spaced between 8.5m and 9.5m apart (Fig. 30, ditches 25005, 25003 and 25007 from west to east). Ditch 25007 was 0.83m wide and 0.32m deep with a bowl-shaped profile, ie curving sides and base (Fig. 36). It contained a single deliberately deposited fill that did not contain finds. Ditch 25003 was 1m wide and at least 0.4m deep with steeply sloping sides, the west steeper than the east, but was not bottomed (Fig. 36). It has a single deliberately deposited fill that did not contain finds. Ditch 25005 was 0.76m wide and at least 0.4m deep with very steep sides flaring at the top, but was not bottomed (Fig. 36, Plate 20). Three sherds of late Iron Age - early Roman pottery were recovered from the deliberately deposited fill (25006), along with a small quantity of charcoal fragments and a single charred hulled wheat grain recovered from environmental sample S.1. No continuations of ditches 25003 or 25005 were seen in Trench 239 to the north, or of any of the ditches in Trench 252 to the south.
- 4.10.9 Many of the ditches on a NNE-SSW alignment share the same steep-sided profile and contain Roman pottery, suggesting that they may have formed a system of this date. They are on a similar alignment to others already described to the north in Trenches 129, 132, 134, 162, 171, 179, 185 and 214.
- 4.10.10 **Trench 222** revealed part of a pit on the east edge of the northern part of the trench (Fig. 25, pit 22303). Pit 22203 had steeply sloping sides and a flattish base slightly higher in the middle than at the edges (Fig. 27). The exposed part measured 0.7m wide by 0.24m deep, and contained a single naturally accumulated fill from which no finds were recovered.

4.11 Trenches 226, 230, 231, 233, 234, 235 and 239 (Fig. 4; Figs 25-9)

- 4.11.1 The remaining evidence in the southern part of the site comprises the remains of ditches on NNW-SSE and ENE-WSW alignments, which are likely to be of post-medieval date. There are one (possibly two) examples in Trenches 226 and 233 (Fig. 26, ditches 22605, 23303 and 23307), another in Trenches 230 and 231 (Fig. 25, ditches 23003 and 23103), two in Trench 234 (Fig. 28, ditches 23402 and 23403) that may be linked to two in Trench 235 (Fig. 28, ditches 23503 and 23505) and to two in Trench 239 (Fig. 29, ditches 23903 and 23904) (Fig. 4). Of these, ditches 22605, 23103, 23402, 23903 and 23904 were not excavated.
- 4.11.2 **Trench 226** revealed one side of a ditch running along the west edge of the trench (Fig. 26). The edge of ditch 22605 curved slightly, becoming

closer to north-south towards the south end of the trench. The edge of this feature was investigated where it appeared to cut a linear feature on a NE-SW alignment (22603), but 22603 was determined to be of natural origin, and the slot was not extended. A discrete circular feature (22602) was also tested, but again provide to be natural. The projected alignment of ditch 22605 is close to the line of ditch 23303 to the south, and this may have been a continuation.

- 4.11.3 **Trench 233** (Fig. 26) contained three features, of which ditch 23305 has already been dealt with (report Section 4.10 above). Ditch 23303 was on a NNW-SSE alignment, though close to north-south, had sloping sides and a cupped base, and was 1.27m wide and 0.44m deep (Fig. 27). Its single fill produced post-medieval brick and tile. Feature 23307 just to the west of 23303, was 2m wide and 0.18m deep, and had shallow sloping sides and an irregular, flattish base. No finds were recovered from the three silty clay fills across the feature. A former field boundary marked on historic maps runs between 23303 and 23307, and it seems clear that one or both features correspond to this. A combination of narrow ditch and broad shallow ditch is also known in connection with a former historic field boundary crossing trenches 234, 235 and 239 (see Figs 28 and 29 below), so both features may relate to this boundary.
- 4.11.4 **Trench 230** (Fig. 25) contained two ditches, of which ditch 23005 has already been described in report section 4.10 above. Ditch 23003 was aligned WSW-ENE, and was 0.74m wide and 0.33m deep with a bowl-profile, ie sloping sides and a cupped base (Fig. 27). It had a single fill, from which one fragment of post-medieval or modern tile and one piece of animal bone were recovered.
- 4.11.5 This ditch was planned crossing **Trench 231**, where it had an irregular outline and varied from 0.7m to 1m wide, but was not excavated (Fig. 25).
- 4.11.6 **Trench 234** contained two ditches at the south end of the trench, a broader ditch (23402) 1.2m wide to the south and a narrower one (23403) only 0.3m wide about 1.5m further north. Neither was excavated, because they were probably continuations of the same two ditches exposed and excavated in Trench 235 to the east.
- 4.11.7 **Trench 235** exposed two ditches, a broad one 1m south of a narrow one, crossing the centre of the trench on an ENE-WSW alignment, angled slight further north than the ditches in Trench 234. Ditch 23505 was the larger ditch, measuring 1.75m wide and 0.31m deep, and had shallow sloping sides and a flattish but somewhat irregular base. The dark greyish-brown fill (23506) contained a fragment of modern glass and two residual flint flakes. Ditch 23503 was 0.4m wide and 0.35m deep, with steeply sloping sides and a rounded base. It contained a single fill that did not produce any finds.
- 4.11.8 **Trench 239** also uncovered a broad ditch (23903) and a narrow ditch (23904) on the same alignment and line as the ditches in Trenches 234 and 235, although in this case the narrow ditch lay 1m south of the wider one. The width of ditch 23903 was not fully exposed, but it was at least 4.5m wide, and narrow ditch 23904 was 0.72m wide; neither ditch was excavated.

4.11.9 The double ditches in Trenches 234, 235 and 239 follow the line of a former ENE-WSW field boundary marked on the late 19th century OS map (OA 2021, figure 7). Dating evidence consistent with this late date has been found in the excavated features. The wide shallow ditches could represent the remains of the grubbed-out hedges, with a narrow ditch alongside, or possibly a ditch on one side of a hedge and a worn track or hollow way on the other. Ditches 23003 and 23103 probably also mark continuations of the same boundary, while ditches at approximately right angles to these in Trench 233 have also produced post-medieval finds. The ditches on similar alignments recorded further north are likely to be associated chronologically with these examples, for which historic and cropmark mapping also suggest consistent alignments.

4.12 Trenches 253, 255, 259, 265, 266, 273 and 276 (Fig. 5; Figs 31-3 and 35-6)

4.12.1 This group of trenches lies within Land Parcel 48C east of the northern end of Land Parcel 48B (Fig. 5). The description of this area is divided between a group of ditches, mostly on a NNW-SSE to north-south alignment, thought to be of similar, possibly Roman date, and other ditches and features of later date, which are dealt with in report section 4.13 below.

4.12.2 Seven ditches in Land Parcel 48C could potentially represent the remains of cultivation ditches of Roman date, one in Trench 253 (Fig. 31, ditch 25303), one in Trench 255 (Fig. 31, ditch 25503), one in Trench 259 (Fig. 32, ditch 25903), one in Trench 266 (Fig. 32, ditch 26602), one in Trench 273 (Fig. 33, ditch 27305) and one (on a NE-SW alignment) in Trench 276 (Fig. 35. Ditch 27603).

4.12.3 **Trench 253** contained one ditch at the east end (Fig. 31, ditch 25303) and several natural features, one of which (25306) was tested. Ditch 25303 measured 0.67m wide and 0.31m deep, and had steeply sloping sides and a flat base (Fig. 36). The ditch contained two fills, the lower numbered 25304, the upper 25305, both described as the result of natural silting, and neither fill contained finds.

4.12.4 **Trench 255** lay some 48m east of Trench 253, and this contained only one ditch, which was in its western half. Ditch 25503 was aligned NNW-SSE, measured 0.65m wide and was at least 0.42m deep with one vertical and one steeply sloping side, but was not bottomed (Fig. 36). The sides flared out at the top, suggesting that the ditch was open long enough for erosion to take place. There was only one fill, which was the result of natural silting, and this did not contain finds. No continuation of either ditch 25303 or 25503 was

4.12.5 **Trench 259** was situated in the north-east corner of the area of Land Parcel 48C available for trenching, and contained a single ditch aligned just westwards of north-south at its western end. This ditch had been truncated by machining, but was 1.1m wide and 0.55m deep in the section, with fairly steeply sloping sides and a flattish bottom (Fig. 36). Its single naturally accumulating fill did not contain finds. The projected line of

this ditch was close to that of ditch 27305, which may therefore have been a continuation (see Fig. 5).

- 4.12.6 **Trench 265** contained one ditch on an alignment slightly westwards of north-south (Fig. 32, ditch 26503), and a natural soilmark on much the same alignment. This ditch had sloping sides and a curved, almost pointed base, and measured 0.88m wide and 0.36m deep (Fig. 36, Plate 24). There were two natural silting fills, 26504 below 26505, and a single small sherd of abraded Roman pottery was recovered from the upper fill.
- 4.12.7 **Trench 266** contained a short length of ditch on an alignment just westwards of north-south, which ran for nearly 17m and had rounded ends (Figs 32 and 33, ditch 26602). This ditch was nearly 1m wide at the top, narrowing to only 0.45m wide at a depth of 0.45m, where excavation ceased due to groundwater. The sides were steep at the top, becoming near-vertical lower down (Fig. 36). There was one fill resulting from natural silting, which did not contain any finds. This ditch was in line with ditch 27303 to the south, and although ditch 26602 terminated within the trench, it is possible that ditch 27303 was associated.
- 4.12.8 **Trench 273** contained two ditches on the same alignment, both being running just slightly westwards of north-south (Fig. 33, ditches 27303 and 27305). Ditch 27303 lay at the eastern edge of the site, parallel with ditch 27305 c 20m to its west. It was 0.94m wide and only 0.19m deep, with shallow sloping sides and a rounded, almost flat base (Fig. 36). No finds were recovered from its deliberately deposited fill. Although of similar width to ditch 26602 to the north, it was much shallower, though the fills were similar, a yellowish-brown and a greyish-brown silty clay respectively.
- 4.12.9 Ditch 27305 was a narrower ditch measuring 0.65m wide and at least 0.3m deep, with one vertical (slightly undercut) side and the other steeply sloping, but was not bottomed. The single fill appeared to consist of redeposited natural, and did not contain any finds. The projected line of this ditch was close to that of ditch 25903 to the north (see Fig. 5), which could therefore have been a continuation, although the distance between them makes this very tentative.
- 4.12.10 **Trench 276** contained a single ditch on a NE to SW alignment (Fig. 35, ditch 27603). This ditch had steeply sloping sides with a flat base and measured 0.5m wide by 0.58m deep (Fig. 36, Plate 23). It had a primary spill down the south-east side, followed by a main naturally accumulating fill. No finds were recovered from either fill.

4.13 Trenches 254, 267 and 274 (Fig. 5; Figs 31, 34 and 36)

- 4.13.1 The remaining ditches in Land Parcel 48C are likely to represent the remains of later, post-medieval agricultural features.
- 4.13.2 **Trench 254** contained a single sinuous ditch (Fig. 31, ditch 25403), running on a NNW-SSE alignment. Ditch 25403 had moderately sloping sides with a rounded, slightly irregular base and measured 0.95m wide by 0.22m deep (Fig. 36). A large, square shafted iron spike or tent peg of recent date was recovered from its naturally accumulated fill. This ditch

corresponded to a former field boundary evident on historic maps (Fig. 31; OA 2021, figure 7).

- 4.13.3 **Trench 267** lay on the west edge of the land parcel, and contained a ditch on a NNW-SSE ditch parallel to the existing field boundary (Fig. 34, ditch 26703) Ditch 26703 measured 0.63m wide by 0.14m deep and exhibited a regular profile with steeply sloping sides and a rounded base (Fig. 36). No finds were recovered from its naturally accumulated fill. It may represent a former field boundary associated with an example depicted in historic mapping c 10m further to the east.
- 4.13.4 **Trench 274** exposed an ill-defined, large natural feature some 20m long from north to south, covering the centre of the trench (Fig. 34, feature 27403). A 1m² box section was excavated encountering the bottom at a depth of 0.38m (Fig. 36, Plate 25). Its single naturally accumulated fill yielded one small sherd of late Iron Age - early Roman pottery, four fragments of fired clay and a fragment of oyster shell. Given the small area from which the finds came, this may have been a shallow quarry or working hollow of Roman date.

4.14 Finds summary

- 4.14.1 **Pottery.** A total of 22 sherds (104g) of pottery were recovered from the evaluation. The pottery comprises a small group of six sherds that could be dated to the late Iron Age or early Roman period from Trenches 181, 217, 250 and 274, along with five sherds of middle Roman pottery from ditch 18103 in Trench 181. The remainder comprised another 11 featureless body sherds, from Trenches 181, 174, 190, 218, 219 and 265, which could be broadly dated to the Roman period.
- 4.14.2 **Ceramic building material.** A small assemblage of nine undated and post-medieval/modern fragments was recovered from Trenches 163, 219, 230 and 233.
- 4.14.3 **Fired clay.** Four fragments were recovered, all entirely undiagnostic and undated. All four fragments were derived from Trench 274.
- 4.14.4 **Worked flint.** A small assemblage of five struck flints was recovered. They comprised two microliths typical of the Mesolithic period from Trenches 136 and 181, two flakes from Trench 235 and a retouched flake from Trench 269.
- 4.14.5 **Metalwork.** Two fragmentary and corroded iron objects were recovered from Trenches 129 and 254. They comprised a fragment of an iron buckle from ditch 12906 and a large iron spike or tent peg from ditch 25403. Both objects are probably of post-medieval or modern date.
- 4.14.6 **Glass.** One fragment of colourless glass was recovered from Trench 235. This was etched with a diamond lattice pattern and may represent a fragment of lamp glass from a motor vehicle.

4.15 Environmental summary

- 4.15.1 **Charred plant remains.** Six samples were assessed from those taken in the evaluation of the site. The only mode of preservation evident in the sampled remains is charring, with the quantity and quality of the charred remains very low. Sample 5 from tree-throw hole 17503 produced the largest quantity of charcoal. Very few whole charred cereal grains or fragments were recovered.
- 4.15.2 **Animal bone.** A very small assemblage of three fragments of animal bone was recovered, from undated ditches in Trenches 132 and 230 and from an ill-defined, undated feature in Trench 194.

5 Discussion

5.1 Reliability of field investigation

- 5.1.1 The archaeological features were reasonably well defined against the underlying London clay and head deposits, although several natural features were sample excavated to establish if they were of geological or archaeological significance. The investigation was undertaken in reasonably fine weather throughout with no periods of rain sufficient to cause any of the trenches to flood and there was no measurable impact associated with prevailing weather conditions.
- 5.1.2 All trenches set out within the WSI were excavated, and only four of these repositioned to account for on-site constraints. During the machining excavation of some trenches in the south of Land Parcel 48B it proved, in places, quite difficult to discern the interface between subsoil deposits and underlying head deposits. This was mitigated through an ongoing review of the activity to adjust the depth of excavation accordingly when the interface was identified. Despite this there remains a possibility that additional archaeological remains were not identified, but on balance, the potential for this is low.
- 5.1.3 Some features were not fully excavated as they extended below the safe working depth of 1m below ground level. However, the depths of these features can be confidently extrapolated based on the predictable profiles of any such features, limiting the impact of this factor. These features were also reviewed during excavation and thought unlikely to provide useful additional information if they were excavated to full depth.
- 5.1.4 There was only limited correlation between the aerial survey cropmarks, the geophysical survey results and archaeological features in most the trenches. Recorded cropmark evidence comprised the remains of former historic field boundaries and these were identified in Trenches 140, 163, 203, 233 and 254. The results of the geophysical survey principally identified field drainage, former historic field boundaries and other agricultural anomalies and probable ferrous/debris spreads. Former field boundary ditches were identified in Trenches 230, 231, 234, 235 and 239. With these exceptions, all other recorded features, comprising ditches, pits, tree-throws and postholes were not evident in these sources.
- 5.1.5 Archaeological features were sparsely distributed throughout the site and where these were present were either naturally infilled with the deposits into which they were dug or deliberately infilled with the same very localised deposits. It is this factor and the typically quite shallow depth of most features – commonly less than 0.5m – that probably resulted in the lack of cropmark evidence and the invisibility of the features in the geophysical survey results. Shallow cut ditches, small pits and postholes are typically not identified on the prevailing geology as cropmarks.
- 5.1.6 On balance, whilst the overall density of archaeological remains within the site was somewhat underrepresented by the cropmark evidence and

geophysical survey results this had no measurable impact on the reliability of the evaluation.

- 5.1.7 Archaeological remains across the site were generally truncated by ploughing, although the features were mostly preserved to a reasonable depth. As noted above also, occasional difficulty in defining the interface between subsoil and head deposits in places at the south end of the site may have resulted in slight over-machining of deposits. This may have further truncated the uppermost elements of features. Despite this, the types, morphology, distribution and preservation of archaeological features that were identified across the site was sufficient to enable a confident interpretation of the results. It is unlikely that historic truncation or any potential over-machining will have otherwise influenced the preservation of remains.

5.2 Interpretation

- 5.2.1 **Mesolithic/Neolithic.** Early prehistoric evidence was limited to two worked flints, both obliquely blunted points, of Mesolithic origin. These were recovered from the infill of a periglacial crack in Trench 136 and a late Iron Age - Roman cultivation ditch in Trench 181.
- 5.2.2 The occurrence of these artefacts in such a small quantity suggests that activity during this period was little more than transitory. This is also consistent with previously recorded evidence within the vicinity, and with that from recent evaluations of the area south of Stifford Clays Road (OA 2020a and OA2020b). Recent evaluation of Land Parcel 48H beyond the Mar Dyke palaeochannel that bounds Land Parcel 48B on the north has revealed a sizeable Mesolithic flint scatter, and the activity in Land Parcel 48B should therefore be seen as peripheral to that focus within the Mar Dyke valley. No activity of the Neolithic or Bronze Age has been identified within the site.
- 5.2.3 **Later prehistoric.** No finds or features were identified that definitely belong to this period. A single small and sinuous ditch was identified in Trench 187 that was cut across by a ditch thought possibly to be part of the Roman agricultural system, and if true, this feature must be of either earlier Roman or prehistoric date. Overall, however, the absence of finds or other features of this period suggests that any activity was sparse or of a nature that did not leave archaeological evidence.
- 5.2.4 **Iron Age and Roman.** The results of the evaluation suggest the site lay within the agricultural hinterland of the later Iron Age and Roman settlement that lay at the top of the southern slope of the Mar Dyke valley (OCA 2020a and OCA 2020b). Remains within the site principally comprised quite narrow, shallow cultivation or agricultural drainage ditches. A number of these across both Land Parcels 48B and 48C, in Trenches 129, 132, 134, 162, 171, 185, 214, 217, 218, 219, 230, 233, 250 and 276, were broadly aligned NE-SW and NNE-SSW. Others, in Trenches 168, 174, 180, 181, 187 and 190, were aligned more or less perpendicular to these on a NW-SE and WNW-ESE alignment. Most of these features did not contain finds, but based on typical morphology and their alignments, are here tentatively associated with the few examples

from which late Iron Age - early Roman pottery (ditches 18107, 21703 and 25003) and Roman pottery (ditches 17403, 18103, 19003, 21803 and 21903) was recovered.

- 5.2.5 A series of other ditches in Land Parcel 48C, in Trenches 253, 255, 259, 265, 266 and 273 are of quite similar morphology to those discussed above but are aligned more north-south. A single abraded sherd of Roman pottery was recovered from Ditch 26503 and hints at a Roman period origin, at least for this ditch, but this may be too little in terms of evidence to assume a contemporary association with the other ditches.
- 5.2.6 The entire pottery assemblage comprises only 22 sherds and with the exception of two comes from ditches in Land Parcel 48B. All were in poor condition, averaged less than 5g in weight and are characteristic of having been subject to heavy disturbance, probably the majority finding their way into feature fills through natural processes. This assemblage also indicates that the site lies at some distance from any focus of settlement, the sherds probably finding their way onto the site by means of rubbish disposal and manuring.
- 5.2.7 Land use on site in the Roman period can be associated with similar evidence recorded during the evaluation of Iron Age and Roman period settlement to the south, higher up the valley slope in Land Parcel 21, Whitfield north of Stifford Road (OCA 2020b). This comprised similar groups of parallel ditches with very steep or vertical sides and flat bases, some of which contained small quantities of Roman pottery. On that site these features were interpreted as drainage features similar to lazy beds.
- 5.2.8 The evidence recorded in Land Parcels 48B and 48C should be considered in conjunction with the cropmark complex visible in part to the north of Stifford Clays Road in Land Parcel 21, but also with the evidence recorded in the evaluation of Land Parcel 22, to the south of Stifford Clays Road (OA 2020a, OA 2020b). This suggests that the present investigation probably represents the outer element of the core settlement's agricultural hinterland.
- 5.2.9 **Post-medieval and modern.** No evidence of occupation or associated settlement activity was identified within the site, although the remains of infilled former field boundary ditches and other ditches that were probably broadly contemporary with these were recorded. These are also evident in the cropmark data and on 19th century historic mapping. The only artefacts recovered that date to the post-medieval or modern periods comprised a very small assemblage of CBM, an iron buckle, an iron shaft or tent peg and a piece of modern glass. Much of this assemblage was recovered from examples of these boundary ditches in Trenches 163, 233, 235 and 254. Possible furrow bases were also recorded in Trenches 211, 267 and 273. These features, based on their relatively wide and shallow profiles, could be of post-medieval origin (or possibly earlier), though remain formally undated. Other undated ditches of similar orientation on the site may well represent further post-medieval field subdivisions prior to the period of the historic maps.

5.3 Evaluation objectives and results

- 5.3.1 This evaluation established the presence of archaeological remains and investigated their character by analysing artefacts and environmental evidence. The evaluation also ground-truthed the cropmark evidence identified by the 2019 aerial survey (Place Services 2019) and the results of the geophysical survey (Magnitude Surveys 2020). The evaluation also investigated the apparently blank areas where no cropmarks were evident and geophysical survey results were either inconclusive or presented no evidence.
- 5.3.2 The archaeological evaluation conducted the investigation within the general research parameters and objectives defined by the revised East of England Research Framework (Medlycott 2011), and took account of the aims and objectives of the Greater Thames Estuary Historic Environment Research Framework.
- 5.3.3 In terms of specific objectives, the evaluation identified dispersed archaeological remains in the northern part of the site, in Land Parcels 48B and 48C and in the southern half of Land Parcel 48B. Cropmark evidence principally comprised former field boundaries, the majority of which were also evident on 19th century historic mapping. Archaeological remains associated with these were accurately identified. With these exceptions, however, the majority of exposed remains had not been evident as cropmarks or in the results of the geophysical survey.
- 5.3.4 This was not due to their being obscured by colluvium or alluvium, which was only identified in Trenches 122 and 136 respectively, rather it is more likely due to the morphology of exposed remains and the deposits with which they had filled. For example, many of the features comprised relatively narrow and shallow ditches, along with small to moderate-sized shallow pits, one posthole and a number of tree-throw holes, which tend not to produce cropmarks or clearly evident geophysical survey results on the London clay and head clay geology. In addition, the majority of naturally infilled features would also have filled with deposits of very similar composition to the surrounding natural substrate, making them more difficult to discern.
- 5.3.5 The evaluation did not find any evidence of activity associated with former palaeochannels within the site. It is probable that the remains of former palaeochannels are located further north beyond this part of the southern valley slope. Similarly, no evidence was identified which could contribute to the clarification of the tidal limit of the former Mar Dyke river.
- 5.3.6 With the exception of a very small residual flint assemblage, no activity of earlier prehistoric date was recorded within the site. Activity on the site began in the late Iron Age - early Roman period and continued throughout the much of the Roman period. This comprised the remains of probable cultivation or drainage ditches across the wider extent of the site in both Land Parcels, though only a very few of these could be dated. These ditches were not evident as cropmarks or in the results of the geophysical survey and so do not have a direct relationship with the cropmark complex to the south of Stifford Clays Road. However, it is highly likely that these

remains represent an element of the wider agricultural hinterland of the settlement that is represented by the focus of the cropmark complex and was evident in the evaluation of Land Parcels 21 and 22 (OA 2020a, OA 2020b). The settlement lay on the higher slopes of the valley, with the agricultural hinterland lying northwards as the landscape drops into the valley.

- 5.3.7 No remains of buildings associated the former late medieval to post-medieval Hobletts Farm, the focus of which lay just to the north-east of Land Parcel 48C, were identified with the site. Similarly, no evidence of remains, which could be associated with the former Botney Farm on the north-east boundary of Land Parcel 48B, were identified.
- 5.3.8 Post-medieval field boundaries corresponding to those depicted on historic maps and evident as cropmarks were identified across the length of Land Parcel 48B and in the west half of Land Parcel 48C. Post-medieval or modern artefacts comprised a very small assemblage of CBM, some undated, an iron buckle, an iron shaft or tent peg and a piece of modern glass. Much of this assemblage was recovered from four of these boundary ditches in Trenches 163, 233, 235 and 254 and provides reasonable dating evidence for them. None provided any evidence suggesting medieval origins.

Appendix A Trench Tables

Trench 121							
General description						Orientation	ENE-WSW
Trench devoid of archaeology. Consists of ploughsoil overlaying natural geology of silty clay and gravel.						Length (m)	30
						Width (m)	1.8
						Avg. depth (m)	0.25
Context No.	Type	Fill Of	Width (m)	Depth (m)	Description	Finds	Date
12100	Layer			0.25	Ploughsoil. Dark greyish brown sandy clay.		
12101	Layer				Natural. Light reddish brown silty clay.		
Trench 122							
General description						Orientation	NW-SE
Trench devoid of archaeology. Consists of ploughsoil overlying subsoil/colluvium and reworked London clay and natural London clay.						Length (m)	30
						Width (m)	2
						Avg. depth (m)	0.33
Context No.	Type	Fill Of	Width (m)	Depth (m)	Description	Finds	Date
12200	Layer			0.33	Ploughsoil. Dark greyish brown. Slightly clayey silt. Mottled with small streaks of mid yellowish sediment.		
12201	Layer			0.27	Possible colluvial Layer. Mid yellowish brown slightly silty clay		
12202	Layer			0.45	Other Layer. Brown mottled with a pale bluish grey tinge. Weathered London clay.		
12203	Layer				Natural. Brown mottled with a bluish grey tinge. Patches of very light yellow/chalky sediment. Pebble inclusions.		
Trench 123							
General description						Orientation	SW-NE
Trench devoid of archaeology. Consists of ploughsoil overlying natural geology.						Length (m)	30
						Width (m)	1.8
						Avg. depth (m)	0.33
Context No.	Type	Fill Of	Width (m)	Depth (m)	Description	Finds	Date
12300	Layer			0.33	Ploughsoil. Dark greyish brown sandy clay.		
12301	Layer				Natural. Light reddish brown silty clay.		
Trench 124							
General description						Orientation	NW-SE

Trench devoid of archaeology. Consists of ploughsoil overlaying natural geology of silty clay and gravel.						Length (m)	30
						Width (m)	1.8
						Avg. depth (m)	0.3
Context No.	Type	Fill Of	Width (m)	Depth (m)	Description	Finds	Date
12400	Layer			0.3	Ploughsoil. Dark greyish sandy clay.		
12401	Layer				Natural. Light reddish brown silty clay.		
Trench 125							
General description						Orientation	NNW-SSE
Trench devoid of archaeology. Consists of ploughsoil and subsoil overlying natural geology of silty clay.						Length (m)	30
						Width (m)	2
						Avg. depth (m)	0.41
Context No.	Type	Fill Of	Width (m)	Depth (m)	Description	Finds	Date
12500	Layer			0.26	Ploughsoil. Dark greyish brown clayey silt.		
12501	Layer			0.15	Subsoil. Mid yellowish brown silty clay.		
12502	Layer				Natural. Light reddish brown silty clay.		
Trench 126							
General description						Orientation	WSW-ENE
Trench devoid of archaeology. Consists of ploughsoil and subsoil overlying natural geology of sandy clay and gravel.						Length (m)	30
						Width (m)	2
						Avg. depth (m)	0.37
Context No.	Type	Fill Of	Width (m)	Depth (m)	Description	Finds	Date
12600	Layer			0.24	Ploughsoil. Dark greyish brown clayey silt.		
12601	Layer			0.13	Subsoil. Mid yellowish brown silty clay.		
12602	Layer				Natural. Light reddish brown sandy clay and gravel.		
Trench 127							
General description						Orientation	ENE-WSW
Trench revealed one ditch and one tree-throw. Consists of ploughsoil and subsoil overlying natural geology of silty clay and gravel.						Length (m)	30
						Width (m)	2
						Avg. depth (m)	0.37
Context No.	Type	Fill Of	Width (m)	Depth (m)	Description	Finds	Date
12700	Layer			0.28	Ploughsoil. Dark greyish brown clayey silt.		
12701	Layer			0.09	Subsoil. Mid yellowish brown silty clay.		
12702	Layer				Natural. Mid reddish brown silty clay and gravel.		
12703	Cut		1.76	0.5	Ditch		

12704	Fill	12703	0.76	0.5	Secondary Fill. Mid greyish brown silty clay		
12705	Cut		1.62	0.34	Tree-throw		
12706	Fill	12705	1.62	0.34	Other Fill. Light grey and charcoal clayey silt		
Trench 128							
General description						Orientation	NE-SW
Trench devoid of archaeology. Consists of ploughsoil and subsoil overlying a natural of silty clay.						Length (m)	30
						Width (m)	2
						Avg. depth (m)	0.3
Context No.	Type	Fill Of	Width (m)	Depth (m)	Description	Finds	Date
12800	Layer			0.21	Ploughsoil. Dark greyish brown clayey silt.		
12801	Layer			0.09	Subsoil. Mid yellowish brown silty clay.		
12802	Layer				Natural. Mid orangish brown silty clay		
Trench 129							
General description						Orientation	NW-SE
Trench revealed one small pit and two ditches. Consists of ploughsoil overlying natural.						Length (m)	30
						Width (m)	2
						Avg. depth (m)	0.24
Context No.	Type	Fill Of	Width (m)	Depth (m)	Description	Finds	Date
12900	Layer			0.24	Ploughsoil. Dark greyish brown clayey silt.		
12901	Layer				Natural. Mid orangey brown, silty clay with gravel inclusions.		
12902	Cut		0.36	0.04	Pit		
12903	Fill	12902	0.37	0.04	Secondary Fill. Mid brownish grey silty clay.		
12904	Cut		2.44	0.45	Ditch		
12905	Fill	12904	2.44	0.75	Deliberate Backfill. Mottled yellowish brown and blue grey silty clay.		
12906	Cut		0.77	0.74	Ditch		
12907	Fill	12906	0.77	0.74	Deliberate Backfill. Mottled mid bluish grey and yellowish brown.	Iron object	Post-med/mod
Trench 130							
General description						Orientation	ENE-WSW
Trench devoid of archaeology. Natural feature excavated. Consists of ploughsoil overlying a silty clay natural.						Length (m)	30
						Width (m)	2
						Avg. depth (m)	0.26
Context No.	Type	Fill Of	Width (m)	Depth (m)	Description	Finds	Date
13000	Layer			0.26	Ploughsoil. Dark greyish brown clayey silt.		

13001	Layer				Natural. Mid reddish brown silty clay with patches of yellowish brown.		
13002	Cut		1.8	0.54	Natural Feature		
13003	Fill	13002	0.71	0.54	Other Fill. Medium blackish grey, silty clay.		
13004	Fill	13002	0.98	0.54	Other Fill. Medium greyish yellow, silty clay.		
13005	Fill	13002	1.44	0.22	Other Fill. Light whitish grey, silty clay.		
13006	Fill	13002	0.37	0.54	Other Fill. Medium greyish brown, silty clay.		
Trench 131							
General description						Orientation	WSW-ENE
Trench revealed one ditch. Consists of ploughsoil and subsoil overlying natural geology of silty clay.						Length (m)	30
						Width (m)	2
						Avg. depth (m)	0.46
Context No.	Type	Fill Of	Width (m)	Depth (m)	Description	Finds	Date
13100	Layer			0.31	Ploughsoil. Dark greyish brown clayey silt.		
13101	Layer			0.15	Subsoil. Mid yellowish brown silty clay.		
13102	Layer				Natural. Mid reddish brown silty clay.		
13103	Cut		0.98	0.4	Ditch		
13104	Fill	13103	0.98	0.4	Deliberate Backfill. Mid greyish brown clayey silt.		
Trench 132							
General description						Orientation	NNW-SSE
Trench revealed four ditches. Consists of ploughsoil and subsoil overlying natural silty clay.						Length (m)	30
						Width (m)	2
						Avg. depth (m)	0.44
Context No.	Type	Fill Of	Width (m)	Depth (m)	Description	Finds	Date
13200	Layer			0.3	Ploughsoil. Dark greyish brown clayey silt.		
13201	Layer			0.14	Subsoil. Mid yellowish brown silty clay.		
13202	Layer				Natural. Mid reddish brown silty clay.		
13203	Cut		0.4	0.1	Ditch		
13204	Fill	13203	0.4	0.1	Secondary Fill. Light brownish grey clayey silt.		
13205	Cut		0.57	0.5	Ditch		
13206	Fill	13205	0.57	0.5	Deliberate Backfill. Mottled grey and yellowish brown silty clay.		
13207	Cut		0.48	0.18	Ditch		
13208	Fill	13207	0.48	0.18	Secondary Fill. Dark greyish brown clayey silt.		
13209	Cut		0.6	0.13	Ditch		
13210	Fill	13209	0.6	0.13	Secondary Fill. Light brownish grey silty clay.		

Trench 133							
General description						Orientation	NNW-SSE
Trench revealed two pits and one posthole. Consists of ploughsoil and subsoil overlying natural geology of silty clay.						Length (m)	30
						Width (m)	2
						Avg. depth (m)	0.43
Context No.	Type	Fill Of	Width (m)	Depth (m)	Description	Finds	Date
13300	Layer			0.28	Ploughsoil. Dark greyish brown clayey silt.		
13301	Layer			0.15	Subsoil. Mid yellowish brown silty clay.		
13302	Layer				Natural. Light reddish brown silty clay and gravel.		
13303	Cut		0.34	0.05	Pit		
13304	Fill	13303	0.34	0.05	Secondary Fill. Dark brown clayey silt.		
13305	Cut		0.37	0.07	Pit		
13306	Fill	13305	0.37	0.07	Secondary Fill. Light brownish grey clayey silt.		
13307	Cut		0.93	0.08	Pit		
13308	Fill	13307	0.93	0.08	Other Fill. Black charcoal.	Sample <6>	
Trench 134							
General description						Orientation	NNW-SSE
Trench revealed one ditch. Consists of ploughsoil and subsoil overlying natural geology of silty clay.						Length (m)	30
						Width (m)	2
						Avg. depth (m)	0.43
Context No.	Type	Fill Of	Width (m)	Depth (m)	Description	Finds	Date
13400	Layer			0.3	Ploughsoil. Dark greyish brown clayey silt.		
13401	Layer			0.13	Subsoil. Mid yellowish brown silty clay.		
13402	Layer				Natural. Light yellowish brown silty clay.		
13403	Cut		0.56	0.1	Ditch		
13404	Fill	13403	0.56	0.1	Secondary Fill. Mid greyish brown silty clay.		
Trench 135							
General description						Orientation	WSW-ENE
Trench devoid of archaeology. Consists of ploughsoil and subsoil overlying natural geology of silty clay.						Length (m)	30
						Width (m)	2
						Avg. depth (m)	0.46
Context No.	Type	Fill Of	Width (m)	Depth (m)	Description	Finds	Date
13500	Layer			0.35	Ploughsoil. Dark greyish brown clayey silt.		
13501	Layer			0.11	Subsoil. Mid yellowish brown silty clay.		
13502	Layer				Natural. Mid reddish brown silty clay.		

Trench 136							
General description						Orientation	NNW-SSE
Trench revealed one pit and one natural feature excavated. Consists of ploughsoil and three alluvial contexts overlying natural geology of London clay, possible gravelly head deposit, that ends 5.9m away from NNW end of trench.						Length (m)	30
						Width (m)	2
						Avg. depth (m)	0.3
Context No.	Type	Fill Of	Width (m)	Depth (m)	Description	Finds	Date
13600	Layer			0.3	Ploughsoil. Dark brownish grey clayey silt.		
13601	Layer			0.26	Alluvial Layer. Mid yellowish brown silty clay.		
13602	Layer			0.22	Alluvial Layer. Dark yellowish brown slightly silty clay.		
13603	Cut		0.77	0.47	Pit		
13604	Fill	13603	1.57	0.47	Primary Fill. Mid blackish grey, silty clay.		
13605	Fill	13603	1.47	0.22	Secondary Fill. Mottled blackish grey with silty clay.		
13606	Cut		1.08	0.61	Ditch		
13607	Fill	13606	0.25	0.16	Primary Fill. Mid greyish yellow, silty clay, with blue clay mottling.		
13608	Fill	13606	0.74	0.28	Primary Fill. Mid brownish grey, silty clay.		
13609	Fill	13606	1.08	0.23	Primary Fill. Mid brownish yellow, silty clay.	Flint	Mesolithic (residual)
13610	Void						
13611	Layer			0.2	Alluvial Layer. Dark yellowish brown mottled with a mid yellowish brown silty clay.		
13612	Layer			0.09	Natural. Mid yellowish brown mottled with light grey silty clay.		
13613	Layer			0.27	Other Layer. Possible head deposit. Mid yellowish reddish brown sandy clay with abundant large rounded pebbles.		
Trench 137							
General description						Orientation	ENE-WSW
Trench devoid of archaeology. Consists of ploughsoil and subsoil overlying natural geology of silty clay and gravel.						Length (m)	30
						Width (m)	2
						Avg. depth (m)	0.4
Context No.	Type	Fill Of	Width (m)	Depth (m)	Description	Finds	Date
13700	Layer			0.29	Ploughsoil. Dark greyish brown clayey silt.		
13701	Layer			0.11	Subsoil. Mid yellowish brown silty clay.		
13702	Layer				Natural. Mid reddish brown silty clay.		
Trench 138							

General description						Orientation	N/W-S/E
Trench devoid of archaeology. Consists of ploughsoil and subsoil overlying natural geology of clay and gravel patches.						Length (m)	30
						Width (m)	2
						Avg. depth (m)	0.5
Context No.	Type	Fill Of	Width (m)	Depth (m)	Description	Finds	Date
13800	Layer			0.3	Ploughsoil. Dark greyish brown, silty clay.		
13801	Layer			0.2	Subsoil. Mid yellowish brown, silty clay.		
13802	Layer				Natural. Dark reddish brown, clay and gravel patches.		
Trench 139							
General description						Orientation	WSW-ENE
Trench devoid of archaeology. Consists of ploughsoil and subsoil overlying natural geology of silty clay.						Length (m)	30
						Width (m)	2
						Avg. depth (m)	0.41
Context No.	Type	Fill Of	Width (m)	Depth (m)	Description	Finds	Date
13900	Layer			0.28	Ploughsoil. Dark greyish brown clayey silt.		
13901	Layer			0.13	Subsoil. Mid yellowish brown silty clay.		
13902	Layer				Natural. Mid reddish brown silty clay.		
Trench 140							
General description						Orientation	WSW-ENE
Trench revealed one ditch. Consists of ploughsoil and subsoil overlying natural geology of silty clay.						Length (m)	30
						Width (m)	2
						Avg. depth (m)	0.42
Context No.	Type	Fill Of	Width (m)	Depth (m)	Description	Finds	Date
14000	Layer			0.28	Ploughsoil. Dark greyish brown clayey silt.		
14001	Layer			0.14	Subsoil. Mid yellowish brown silty clay.		
14002	Layer				Natural. Mid reddish brown silty clay.		
14003	Cut		0.86	0.35	Ditch		
14004	Fill	14003	0.86	0.35	Secondary Fill. Dark grey silt.		
Trench 141							
General description						Orientation	NNW-SSE
Trench devoid of archaeology. Consists of ploughsoil and subsoil overlying natural geology of silty clay.						Length (m)	30
						Width (m)	2
						Avg. depth (m)	0.42
Context No.	Type	Fill Of	Width (m)	Depth (m)	Description	Finds	Date

14100	Layer			0.28	Ploughsoil. Dark greyish brown clayey silt.		
14101	Layer			0.14	Subsoil. Mid yellowish brown silty clay.		
14102	Layer				Natural. Mid reddish brown silty clay.		
Trench 142							
General description						Orientation	WSW-ENE
Trench revealed one ditch and one natural feature excavated. Consists of ploughsoil and subsoil overlying natural geology of silty clay.						Length (m)	30
						Width (m)	2
						Avg. depth (m)	0.39
Context No.	Type	Fill Of	Width (m)	Depth (m)	Description	Finds	Date
14200	Layer			0.29	Ploughsoil. Dark greyish brown clayey silt.		
14201	Layer			0.1	Subsoil. Mid yellowish brown silty clay.		
14202	Layer				Natural. Mid reddish brown silty clay and gravel.		
14203	Cut		0.83	0.61	Natural Feature		
14204	Fill	14203	0.45	0.07	Primary Fill. Mid greyish yellow, silty clay.		
14205	Fill	14203	0.83	0.54	Secondary Fill. Medium bluish brown, silty clay.		
14206	Unexcavated feature		1.11		Ditch		
Trench 143							
General description						Orientation	NNW-SSE
Trench revealed one ditch. Consists of ploughsoil and subsoil overlying natural geology of silty clay.						Length (m)	30
						Width (m)	2
						Avg. depth (m)	0.39
Context No.	Type	Fill Of	Width (m)	Depth (m)	Description	Finds	Date
14300	Layer			0.3	Ploughsoil. Dark greyish brown clayey silt.		
14301	Layer			0.09	Subsoil. Mid yellowish brown silty clay.		
14302	Layer				Natural. Mid reddish brown silty clay.		
14303	Cut		0.6	0.24	Ditch		
14304	Fill	14303	0.6	0.24	Primary Fill. Mid greyish brown, silty clay.		
Trench 144							
General description						Orientation	N/E-S/W
Trench revealed three ditches. Consists of ploughsoil and subsoil overlying natural geology of clay and gravel patches.						Length (m)	30
						Width (m)	2
						Avg. depth (m)	0.45
Context No.	Type	Fill Of	Width (m)	Depth (m)	Description	Finds	Date
14400	Layer		2	0.25	Ploughsoil. Dark greyish brown, silty clay.		

14401	Layer		2	0.2	Subsoil. Mid reddish brown, silty clay.		
14402	Layer		2		Natural. Dark reddish brown, silty clay and gravel patches.		
14403	Cut		1.17	1.19	Ditch		
14404	Fill	14403	1.17	1.19	Primary Fill. Mid greyish brown, silty clay.		
14405	Cut		1.46	0.44	Ditch		
14406	Fill	14405	1.12	0.44	Primary Fill. Med bluish grey, silty clay.		
14407	Fill	14405	0.59	0.3	Secondary Fill. Mottled yellow/greyish brown and greyish blue, silty clay.		
14408	Cut		0.96	0.39	Ditch		
14409	Fill	14408	0.96	0.39	Secondary Fill. Med orange brown mottled with med brownish grey, silty clay.		
14410	Fill	14408	0.63	0.24	Secondary Fill. Med brownish grey, silty clay.		

Trench 145

General description						Orientation	WSW-ENE
Trench devoid of archaeology. Consists of ploughsoil and subsoil overlying natural geology of silty clay and gravel.						Length (m)	30
						Width (m)	2
						Avg. depth (m)	0.4
Context No.	Type	Fill Of	Width (m)	Depth (m)	Description	Finds	Date
14500	Layer			0.29	Ploughsoil. Dark greyish brown clayey silt.		
14501	Layer			0.11	Subsoil. Mid yellowish brown silty clay.		
14502	Layer				Natural. Mid reddish brown silty clay and gravel.		

Trench 146

General description						Orientation	NW-SE
Trench devoid of archaeology. Consists of ploughsoil, subsoil and a bluish silty clay layer, within a depression, overlying natural geology of silty clay and gravel. The trench enters a depression midway to the SE end. Sondage excavated to 1m at SE end.						Length (m)	30
						Width (m)	2
						Avg. depth (m)	0.38
Context No.	Type	Fill Of	Width (m)	Depth (m)	Description	Finds	Date
14600	Layer			0.2	Ploughsoil. Dark greyish brown clayey silt.		
14601	Layer			0.18	Subsoil. Mid yellowish brown silty clay.		
14602	Layer			0.43	Natural. Mid greyish blue silty clay mottled brownish yellow, not bottomed Bedrock. LONDON CLAY FORMATION.		
14603	Layer				Natural. Mid reddish brown silty clay.		

Trench 147

General description						Orientation	WSW-ENE
---------------------	--	--	--	--	--	-------------	---------

Trench devoid of archaeology. Consists of ploughsoil, subsoil overlying natural geology of clay.						Length (m)	30
						Width (m)	2
						Avg. depth (m)	0.4
Context No.	Type	Fill Of	Width (m)	Depth (m)	Description	Finds	Date
14700	Layer			0.3	Ploughsoil. Dark greyish brown clayey silt.		
14701	Layer			0.1	Subsoil. Mid yellowish brown silty clay.		
14702	Layer				Natural. Mid reddish brown silty clay.		
14703	Cut				Natural Feature		
14704	Void						
Trench 148							
General description						Orientation	NNW-SSE
Trench revealed one cultivation ditch. Consists of ploughsoil, subsoil overlying natural geology of clay.						Length (m)	30
						Width (m)	2
						Avg. depth (m)	0.41
Context No.	Type	Fill Of	Width (m)	Depth (m)	Description	Finds	Date
14800	Layer			0.3	Ploughsoil. Dark greyish brown clayey silt.		
14801	Layer			0.11	Subsoil. Mid yellowish brown silty clay.		
14802	Layer				Natural. Mid reddish brown silty clay and gravel.		
14803	Cut		0.84	0.46	Ditch		
14804	Fill	14803	0.84	0.46	Deliberate Backfill. Mid greyish brown silty clay.		
Trench 149							
General description						Orientation	WSW-ENE
Trench devoid of archaeology. Consists of ploughsoil and subsoil overlying natural geology of silty clay.						Length (m)	30
						Width (m)	2
						Avg. depth (m)	0.37
Context No.	Type	Fill Of	Width (m)	Depth (m)	Description	Finds	Date
14900	Layer			0.26	Ploughsoil. Dark greyish brown clayey silt.		
14901	Layer			0.11	Subsoil. Mid yellowish brown silty clay.		
14902	Layer				Natural. Mid reddish brown silty clay.		
Trench 150							
General description						Orientation	N/W-S/E
Trench devoid of archaeology. Consists of ploughsoil and subsoil overlying natural geology of clay.						Length (m)	30
						Width (m)	2
						Avg. depth (m)	0.55
Context No.	Type	Fill Of	Width (m)	Depth (m)	Description	Finds	Date

15000	Layer		2	0.3	Ploughsoil. Dark greyish brown, silty clay.		
15001	Layer		2	0.25	Subsoil. Mid yellowish brown, silty clay.		
15002	Layer		2		Natural. Mid reddish brown, clay and gravel patches.		
Trench 151							
General description						Orientation	NNW-SSE
Trench devoid of archaeology. Consists of ploughsoil and subsoil overlying natural geology of clay.						Length (m)	30
						Width (m)	2
						Avg. depth (m)	0.48
Context No.	Type	Fill Of	Width (m)	Depth (m)	Description	Finds	Date
15100	Layer			0.2	Ploughsoil. Dark greyish brown, silty clay.		
15101	Layer			0.28	Subsoil. Mid yellowish brown, silty clay.		
15102	Layer				Natural. Dark reddish brown, clay with sandy gravel patches.		
Trench 152							
General description						Orientation	ENE-WSW
Trench devoid of archaeology. Consists of ploughsoil and subsoil overlying natural geology of clay.						Length (m)	30
						Width (m)	2
						Avg. depth (m)	0.5
Context No.	Type	Fill Of	Width (m)	Depth (m)	Description	Finds	Date
15200	Layer			0.25	Ploughsoil. Dark greyish brown, silty clay.		
15201	Layer			0.25	Subsoil. Mid yellowish brown, silty clay.		
15202	Layer				Natural. Dark reddish brown, clay.		
15203	Void						
Trench 153							
General description						Orientation	NNW-SSE
Trench devoid of archaeology. Consists of ploughsoil and subsoil overlying natural geology of clay.						Length (m)	30
						Width (m)	2
						Avg. depth (m)	0.41
Context No.	Type	Fill Of	Width (m)	Depth (m)	Description	Finds	Date
15300	Layer			0.3	Ploughsoil. Dark greyish brown clayey silt.		
15301	Layer			0.11	Subsoil. Mid yellowish brown silty clay.		
15302	Layer				Natural. Mid reddish brown silty clay.		
Trench 154							
General description						Orientation	ENE-WSW

Trench devoid of archaeology. Consists of ploughsoil and subsoil overlying natural geology of silty clay.						Length (m)	30
						Width (m)	2
						Avg. depth (m)	0.4
Context No.	Type	Fill Of	Width (m)	Depth (m)	Description	Finds	Date
15400	Layer			0.28	Ploughsoil. Dark greyish brown clayey silt.		
15401	Layer			0.12	Subsoil. Mid yellowish brown silty clay.		
15402	Layer				Natural. Mid reddish brown silty clay.		

Trench 155

General description						Orientation	NNW-SSE
Trench devoid of archaeology. Consists of ploughsoil and subsoil overlying natural geology of clay.						Length (m)	30
						Width (m)	2
						Avg. depth (m)	0.43
Context No.	Type	Fill Of	Width (m)	Depth (m)	Description	Finds	Date
15500	Layer			0.36	Ploughsoil. Dark greyish brown clayey silt.		
15501	Layer			0.07	Subsoil. Mid yellowish brown silty clay.		
15502	Layer				Natural. Mid reddish brown silty clay.		

Trench 156

General description						Orientation	ENE-WSW
Trench devoid of archaeology. Consists of ploughsoil and subsoil overlying natural geology of silty clay.						Length (m)	30
						Width (m)	2
						Avg. depth (m)	0.35
Context No.	Type	Fill Of	Width (m)	Depth (m)	Description	Finds	Date
15600	Layer			0.25	Ploughsoil. Dark greyish brown clayey silt.		
15601	Layer			0.1	Subsoil. Mid yellowish brown silty clay.		
15602	Layer				Natural. Mid reddish brown silty clay.		

Trench 157

General description						Orientation	ENE-WSW
Trench devoid of archaeology. Consists of ploughsoil and subsoil overlying natural geology of silty clay.						Length (m)	30
						Width (m)	2
						Avg. depth (m)	0.35
Context No.	Type	Fill Of	Width (m)	Depth (m)	Description	Finds	Date
15700	Layer			0.28	Ploughsoil. Dark greyish brown clayey silt.		
15701	Layer			0.07	Subsoil. Mid yellowish brown.		
15702	Layer				Natural. Mid reddish brown silty clay.		

Trench 158							
General description						Orientation	NNW-SSE
Trench devoid of archaeology. Consists of ploughsoil and subsoil overlying natural geology of silty clay.						Length (m)	30
						Width (m)	2
						Avg. depth (m)	0.38
Context No.	Type	Fill Of	Width (m)	Depth (m)	Description	Finds	Date
15800	Layer			0.26	Ploughsoil. Dark greyish brown clayey silt.		
15801	Layer			0.12	Subsoil. Mid yellowish brown silty clay.		
15802	Layer				Natural. Mid reddish brown silty clay.		
Trench 159							
General description						Orientation	ENE-WSW
Trench devoid of archaeology. Consists of ploughsoil and subsoil overlying natural geology of silty clay.						Length (m)	30
						Width (m)	3
						Avg. depth (m)	0.4
Context No.	Type	Fill Of	Width (m)	Depth (m)	Description	Finds	Date
15900	Layer			0.3	Ploughsoil. Dark greyish brown clayey silt.		
15901	Layer			0.1	Subsoil. Mid yellowish brown silty clay.		
15902	Layer				Natural. Mid reddish brown silty clay.		
Trench 160							
General description						Orientation	SSE-NNW
Trench devoid of archaeology. Consists of ploughsoil and subsoil overlying natural geology of silty clay.						Length (m)	30
						Width (m)	2
						Avg. depth (m)	0.41
Context No.	Type	Fill Of	Width (m)	Depth (m)	Description	Finds	Date
16000	Layer			0.31	Ploughsoil. Dark greyish brown clayey silt.		
16001	Layer			0.1	Subsoil. Mid yellowish brown silty clay.		
16002	Layer				Natural. Mid reddish brown silty clay.		
Trench 161							
General description						Orientation	ENE-WSW
Trench devoid of archaeology. Consists of ploughsoil and subsoil overlying natural geology of silty clay.						Length (m)	30
						Width (m)	2
						Avg. depth (m)	0.42
Context No.	Type	Fill Of	Width (m)	Depth (m)	Description	Finds	Date
16100	Layer			0.3	Ploughsoil. Dark greyish brown clayey silt.		

16101	Layer			0.12	Subsoil. Mid yellowish brown silty clay.		
16102	Layer				Natural. Mid reddish brown silty clay.		
Trench 162							
General description						Orientation	E-W
Trench revealed two ditches. Consists of ploughsoil and subsoil overlying natural geology of clay.						Length (m)	30
						Width (m)	2
						Avg. depth (m)	0.58
Context No.	Type	Fill Of	Width (m)	Depth (m)	Description	Finds	Date
16200	Layer		2	30	Ploughsoil. Dark greyish brown, silty clay.		
16201	Layer		2	0.3	Subsoil. Mid yellowish brown, silty clay.		
16202	Layer		2		Natural. Dark reddish brown, clay.		
16203	Cut		1.64	0.4	Ditch. Cut of ditch		
16204	Fill	16203	1.02	0.38	Primary Fill. Firm, dark bluish black, silty sand		
16205	Fill	16203	0.44	0.4	Secondary Fill. Hard, med whitish grey, silty clay (powdery)		
16206	Fill	16203	0.34	0.4	Tertiary Fill. Hard, mottled med orangish brown, silty clay		
16207	Cut		0.88	0.28	Ditch. Cut of ditch		
16208	Fill	16207	0.88	0.28	Primary Fill. Firm, med reddish brown, silty clay		
Trench 163							
General description						Orientation	NNW-SSE
Trench revealed a single ditch. Consists of ploughsoil and subsoil overlying natural clay.						Length (m)	30
						Width (m)	2
						Avg. depth (m)	0.41
Context No.	Type	Fill Of	Width (m)	Depth (m)	Description	Finds	Date
16300	Layer			0.28	Ploughsoil. Dark greyish brown clayey silt.		
16301	Layer			0.13	Subsoil. Mid yellowish brown silty clay.		
16302	Layer				Natural. Mid reddish brown silty clay.		
16303	Cut		0.99	0.35	Ditch		
16304	Fill	16303	0.99	0.35	Primary Fill. Med brownish grey, silty clay.	CBM	undated
Trench 164							
General description						Orientation	ENE-WSW
Trench devoid of archaeology. Consists of ploughsoil and subsoil overlying natural geology of silty clay.						Length (m)	30
						Width (m)	2
						Avg. depth (m)	0.46
Context	Type	Fill Of	Width	Depth	Description	Finds	Date

No.			(m)	(m)			
16400	Layer			0.32	Ploughsoil. Dark greyish brown clayey silt.		
16401	Layer			0.14	Subsoil. Mid yellowish brown silty clay.		
16402	Layer				Other Layer. Dark greyish brown silty clay.		
16403	Layer			0.35	Alluvial Layer. Mid yellowish brown clayey sand with large strong brown patches		
Trench 165							
General description						Orientation	NNW-SSE
Trench devoid of archaeology. Consists of ploughsoil and subsoil overlying natural geology of silty clay.						Length (m)	30
						Width (m)	2
						Avg. depth (m)	0.49
Context No.	Type	Fill Of	Width (m)	Depth (m)	Description	Finds	Date
16500	Layer				Ploughsoil. Mid greyish brown clayey silt		
16501	Layer				Subsoil		
16502	Layer				Natural		
16503	Void						
16504	Void						
16505	Void						
16506	Void						
Trench 166							
General description						Orientation	ENE-WSW
Trench devoid of archaeology. Consists of ploughsoil and subsoil overlying natural geology of silty clay.						Length (m)	30
						Width (m)	2
						Avg. depth (m)	0.41
Context No.	Type	Fill Of	Width (m)	Depth (m)	Description	Finds	Date
16600	Layer			0.28	Ploughsoil. Dark greyish brown clayey silt.		
16601	Layer			0.13	Subsoil. Mid yellowish brown silty clay.		
16602	Layer				Natural. Mid reddish brown silty clay.		
Trench 167							
General description						Orientation	NNW-SSE
Trench devoid of archaeology. Consists of ploughsoil and subsoil overlying natural geology of silty clay.						Length (m)	30
						Width (m)	2
						Avg. depth (m)	0.38
Context No.	Type	Fill Of	Width (m)	Depth (m)	Description	Finds	Date
16700	Layer			0.28	Ploughsoil. Dark greyish brown clayey silt.		
16701	Layer			0.1	Subsoil. Mid yellowish		

					brown silty clay.		
16702	Layer				Natural. Mid reddish brown silty clay.		
Trench 168							
General description						Orientation	NE-SW
Trench revealed a single ditch. Consists of ploughsoil and subsoil overlying natural geology of silty clay.						Length (m)	30
						Width (m)	2
						Avg. depth (m)	0.61
Context No.	Type	Fill Of	Width (m)	Depth (m)	Description	Finds	Date
16800	Layer		2	0.25	Ploughsoil. Dark greyish brown, silty clay.		
16801	Layer		2	0.36	Subsoil. Mid yellowish brown, silty clay.		
16802	Layer		2		Natural. Dark reddish brown, clay.		
16803	Cut		0.8	0.43	Ditch		
16804	Fill	16803	0.25	0.43	Primary Fill. Light yellowish brown, silty clay.		
16805	Fill	16803	0.64	0.43	Primary Fill. Mid greyish brown, silty clay.		
Trench 169							
General description						Orientation	E-W
Trench devoid of archaeology. Consists of ploughsoil and subsoil overlying natural geology of silty clay.						Length (m)	30
						Width (m)	2
						Avg. depth (m)	0.6
Context No.	Type	Fill Of	Width (m)	Depth (m)	Description	Finds	Date
16900	Layer		2	0.3	Ploughsoil. Dark greyish brown, silty clay.		
16901	Layer		2	0.3	Subsoil. Mid reddish brown, silty clay.		
16902	Layer		2		Natural. Dark reddish brown, clay.		
Trench 170							
General description						Orientation	N-S
Trench revealed one tree-throw. Consists of ploughsoil and subsoil overlying natural geology of clay.						Length (m)	30
						Width (m)	2
						Avg. depth (m)	0.47
Context No.	Type	Fill Of	Width (m)	Depth (m)	Description	Finds	Date
17000	Layer		2	0.27	Ploughsoil. Dark greyish brown, silty clay.		
17001	Layer		2	0.2	Subsoil. Mid reddish brown, silty clay.		
17002	Layer		2		Natural. Dark reddish brown, clay.		
17003	Cut		1	0.22	Tree-throw		
17004	Fill	17003	1	0.22	Other Fill. Mid greyish brown silty clay.		

Trench 171							
General description						Orientation	N-S
Trench revealed two ditches. One of the ditches cuts the other. Consists of ploughsoil and subsoil overlying natural geology of clay.						Length (m)	30
						Width (m)	2
						Avg. depth (m)	0.56
Context No.	Type	Fill Of	Width (m)	Depth (m)	Description	Finds	Date
17100	Layer			0.36	Ploughsoil. Dark greyish brown clayey silt.		
17101	Layer			0.2	Subsoil. Light yellowish brown silty clay.		
17102	Layer				Natural. Mid greyish orange sandy clay and gravel.		
17103	Cut		0.68	0.26	Ditch		
17104	Fill	17103	0.68	0.26	Primary Fill. Med blackish grey, silty clay.		
17105	Cut		1	0.25	Ditch		
17106	Fill	17105	1	0.25	Primary Fill. Med yellowish brown, silty clay, frequent patches of charcoal.		
Trench 172							
General description						Orientation	E--W
Trench devoid of archaeology. Consists of ploughsoil and subsoil overlying natural geology of silty clay.						Length (m)	30
						Width (m)	2
						Avg. depth (m)	0.53
Context No.	Type	Fill Of	Width (m)	Depth (m)	Description	Finds	Date
17200	Layer			0.33	Ploughsoil. Dark greyish brown clayey silt.		
17201	Layer			0.2	Subsoil. Light greyish brown silty clay.		
17202	Layer				Natural. Mid greyish orange sandy clay.		
Trench 173							
General description						Orientation	N-S
Trench devoid of archaeology. Consists of ploughsoil and subsoil overlying natural geology of silty clay.						Length (m)	30
						Width (m)	2
						Avg. depth (m)	0.46
Context No.	Type	Fill Of	Width (m)	Depth (m)	Description	Finds	Date
17300	Layer			0.34	Ploughsoil. Dark greyish brown clayey silt.		
17301	Layer			0.12	Subsoil. Light greyish brown silty clay.		
17302	Layer				Natural. Mid yellowish brown silty clay.		
Trench 174							
General description						Orientation	N/E-S/W
Trench revealed a single ditch. Consists of ploughsoil and subsoil overlying natural geology of clay.						Length (m)	30
						Width (m)	2

							Avg. depth (m)	0.6
Context No.	Type	Fill Of	Width (m)	Depth (m)	Description	Finds	Date	
17400	Layer			0.3	Ploughsoil. Dark greyish brown, silty clay.			
17401	Layer			0.3	Subsoil. Mid yellowish brown, silty clay.			
17402	Layer				Natural. Dark reddish brown, clay.			
17403	Cut		1.1	0.59	Ditch			
17404	Fill	17403	0.33	0.07	Primary Fill. Mottled blueish/yellowish grey brown, silty clay.			
17405	Fill	17403	0.9	0.5	Primary Fill. Light reddish brown, silty clay.			
17406	Fill	17403	0.8	0.43	Primary Fill. Mottled blueish/yellowish grey brown, silty clay.	Pot	AD40-410	
Trench 175								
General description						Orientation	NW-SE	
Trench revealed a single tree-throw with signs of burning. Consists of ploughsoil and subsoil overlying natural geology of clay.						Length (m)	30	
						Width (m)	2	
						Avg. depth (m)	0.45	
Context No.	Type	Fill Of	Width (m)	Depth (m)	Description	Finds	Date	
17500	Layer			0.25	Ploughsoil. Dark greyish brown, silty clay.			
17501	Layer			0.2	Subsoil. Mid yellowish brown, silty clay.			
17502	Layer				Natural. Dark reddish brown, clay.			
17503	Cut				Tree-throw			
17504	Fill	17503			Primary Fill. Dark greyish brown, silty clay with charcoal.	Sample <5>		
Trench 176								
General description						Orientation	E-W	
Trench devoid of archaeology. Plough soil and sub soil overlying a natural clay geology.						Length (m)	30	
						Width (m)	2	
						Avg. depth (m)	0.42	
Context No.	Type	Fill Of	Width (m)	Depth (m)	Description	Finds	Date	
17600	Layer				Natural. Mid reddish brown silty clay.			
17601	Layer			0.12	Subsoil. Mid reddish brown clay silt.			
17602	Layer			0.3	Ploughsoil. Dark reddish brown, silty clay.			
Trench 177								
General description						Orientation	SSE-NNW	
Trench devoid of archaeology. Consists of ploughsoil and subsoil overlying natural geology of silty clay.						Length (m)	30	
						Width (m)	2	

						Avg. depth (m)	0.52
Context No.	Type	Fill Of	Width (m)	Depth (m)	Description	Finds	Date
17700	Layer			0.36	Ploughsoil. Dark greyish brown clayey silt.		
17701	Layer			0.16	Subsoil. Mid yellowish brown silty clay.		
17702	Layer				Natural. Light greyish orange silty clay.		
Trench 178							
General description						Orientation	WNW-ESE
Trench revealed one ditch. Consists of ploughsoil and subsoil overlying natural geology of silty clay						Length (m)	30
						Width (m)	2
						Avg. depth (m)	0.43
Context No.	Type	Fill Of	Width (m)	Depth (m)	Description	Finds	Date
17800	Layer			0.31	Ploughsoil. Dark greyish brown clayey silt.		
17801	Layer			0.12	Subsoil. Mid yellowish brown silty clay.		
17802	Layer				Natural. Mid greyish orange silty clay.		
17803	Cut		0.25	1.37	Ditch		
17804	Fill	17803	1.37	0.25	Primary Fill. Mottled brownish orange and greyish blue, silty clay.		
Trench 179							
General description						Orientation	NW-SE
Trench revealed two ditches. Consists of ploughsoil and subsoil overlying natural geology of silty clay.						Length (m)	30
						Width (m)	2
						Avg. depth (m)	0.65
Context No.	Type	Fill Of	Width (m)	Depth (m)	Description	Finds	Date
17900	Layer		2	0.38	Ploughsoil. Dark greyish brown, silty clay		
17901	Layer		2	0.27	Subsoil. Mid yellowish brown, silty clay.		
17902	Layer		2		Natural. Light reddish brown, clay.		
17903	Cut		0.99	0.42	Ditch		
17904	Fill	17903	0.37	0.42	Primary Fill. Mottled med yellowish brown, silty clay.		
17905	Fill	17903	0.63	0.42	Secondary Fill. Med greyish blue, silty clay.		
17906	Cut		1.17	0.37	Ditch		
17907	Fill	17906	1.17	0.37	Primary Fill. Med brownish grey, silty clay.		
Trench 180							
General description						Orientation	NE-SW
Trench revealed one ditch. Consists of ploughsoil and subsoil overlying natural geology of clay.						Length (m)	30
						Width (m)	2

						Avg. depth (m)	0.5
Context No.	Type	Fill Of	Width (m)	Depth (m)	Description	Finds	Date
18000	Layer			0.26	Ploughsoil. Dark greyish brown clayey silt.		
18001	Layer			0.25	Subsoil. Mid yellowish brown silty clay.		
18002	Layer				Natural. Mid reddish brown silty clay.		
18003	Cut		0.96	0.49	Ditch		
18004	Fill	18003	0.96	0.49	Deliberate Backfill. Mid greyish brown clayey silt.		
18005	Cut		0.69	0.4	Natural Feature. Likely tree-throw		
Trench 181							
General description						Orientation	N-S
Trench revealed two ditches and one pit. Consists of plough and sub soil overlaying natural clay geology.						Length (m)	30
						Width (m)	2
						Avg. depth (m)	0.4
Context No.	Type	Fill Of	Width (m)	Depth (m)	Description	Finds	Date
18100	Layer				Natural. Mid yellowish brown. silty clay.		
18101	Layer			0.34	Subsoil. Mid yellowish brown, silty clay.		
18102	Layer			0.2	Ploughsoil. Dark reddish brown clayey silt.		
18103	Cut		1.1	1	Ditch		
18104	Fill	18103	1.1	1	Deliberate Backfill. Greyish mid-brown clayey silt.	Pot	AD140-250
18105	Cut		1.15	0.16	Pit		
18106	Fill	18105	1.15	0.16	Primary Fill. Dark greyish brown clayey silt.		
18107	Cut		1.6	0.7	Ditch		
18108	Fill	18107		0.7	Secondary Fill. Mid grey clay.	Pot Pot Flint	AD40-410 LIA/ERB (residual)
Trench 182							
General description						Orientation	E-W
Trench revealed one ditch. Subsoil and plough soil overlaying silty clay.						Length (m)	30
						Width (m)	2
						Avg. depth (m)	0.38
Context No.	Type	Fill Of	Width (m)	Depth (m)	Description	Finds	Date
18200	Layer				Natural. Mid yellowish brown, silty clay.		
18201	Layer			0.2	Subsoil. Mid yellowish brown, silty clay.		
18202	Layer			0.18	Ploughsoil. Dark reddish brown, clayey silt.		
18203	Unexcavated feature		0.81		Ditch. Cultivation ditch. Light yellowish grey silty clay. Same as in trench 181.		

Trench 183							
General description						Orientation	N-S
Trench devoid of archaeology. Consists of ploughsoil and subsoil overlying natural geology of silty clay.						Length (m)	30
						Width (m)	2
						Avg. depth (m)	0.4
Context No.	Type	Fill Of	Width (m)	Depth (m)	Description	Finds	Date
18300	Layer			0.28	Ploughsoil. Mid brownish grey clayey silt.		
18301	Layer			0.12	Subsoil. Mid yellowish grey silty clay.		
18302	Layer				Natural. Light yellowish brown silty clay.		
Trench 184							
General description						Orientation	E-W
Trench revealed a single ditch. Consists of ploughsoil and subsoil overlying natural geology of clay.						Length (m)	30
						Width (m)	2
						Avg. depth (m)	0.42
Context No.	Type	Fill Of	Width (m)	Depth (m)	Description	Finds	Date
18400	Layer			0.32	Ploughsoil. Dark greyish-brown silty clay.		
18401	Layer			0.1	Subsoil. Mid reddish-brown silty clay.		
18402	Layer				Natural. Mid reddish brown silty clay.		
18403	Cut		0.75	0.41	Ditch		
18404	Fill	18403	0.75	0.41	Primary Fill. Mid greyish brown, silty clay		
Trench 185							
General description						Orientation	N-S
Trench revealed one ditch. Consists of ploughsoil and subsoil overlying natural geology of silty clay.						Length (m)	30
						Width (m)	2
						Avg. depth (m)	0.38
Context No.	Type	Fill Of	Width (m)	Depth (m)	Description	Finds	Date
18500	Layer			0.28	Ploughsoil. Mid greyish-brown clay.		
18501	Layer			0.1	Subsoil. Mid yellowish-brown.		
18502	Layer				Natural. Dark reddish-brown.		
18503	Cut		0.98	0.3	Ditch		
18504	Fill	18503	0.98	0.3	Deliberate Backfill. Mid greyish brown silty clay.		
Trench 186							
General description						Orientation	E-W
Trench devoid of archaeology. Consists of ploughsoil and subsoil overlying natural						Length (m)	30

geology of silty clay.						Width (m)	2
						Avg. depth (m)	0.59
Context No.	Type	Fill Of	Width (m)	Depth (m)	Description	Finds	Date
18600	Layer			0.3	Ploughsoil. Mid greyish-brown silty clay.		
18601	Layer			0.29	Subsoil. Dark reddish-brown clay.		
18602	Layer				Natural. Mid yellowish red clay.		
Trench 187							
General description						Orientation	N-S
Trench revealed four ditches. Consists of ploughsoil and subsoil overlying natural geology of clay.						Length (m)	30
						Width (m)	2
						Avg. depth (m)	0.62
Context No.	Type	Fill Of	Width (m)	Depth (m)	Description	Finds	Date
18700	Layer		2	0.28	Ploughsoil. Dark greyish brown, silty clay.		
18701	Layer		2	0.34	Subsoil. Mid reddish brown, silty clay.		
18702	Layer		2		Natural. Dark reddish brown, clay.		
18703	Cut		1.08	0.42	Ditch		
18704	Fill	18703	0.6	0.27	Deliberate Backfill. Greyish-mid brown, silty clay.		
18705	Cut		0.85		Ditch		
18706	Fill	18705	0.85		Primary Fill. Med brownish grey, silty clay.		
18707	Cut		1.21	0.32	Ditch		
18708	Fill	18707	1.21	0.32	Primary Fill. Med greyish brown, silty clay.		
18709	Cut		0.43	0.12	Ditch		
18710	Fill	18709	0.43	0.12	Primary Fill. Med reddish brown, silty clay.		
18711	Fill	18703	1.08	0.42	Primary Fill. Firm, dark bluish grey, silty clay, occasional stones		
Trench 188							
General description						Orientation	NE-SW
Trench revealed one ditch. Consists of ploughsoil and subsoil overlying natural geology of silty clay.						Length (m)	30
						Width (m)	2
						Avg. depth (m)	0.42
Context No.	Type	Fill Of	Width (m)	Depth (m)	Description	Finds	Date
18800	Layer			0.29	Ploughsoil. Mid blackish brown, silty clay.		
18801	Layer			0.13	Subsoil. Mid brown, silty clay.		
18802	Layer				Natural. Mid reddish brown, silty clay.		
18803	Unexcavated feature		0.51		Ditch. Cultivation ditch. Light yellowish grey silty		

					clay. Same as in 187.		
Trench 189							
General description						Orientation	NW-SE
Trench devoid of archaeology. Consists of ploughsoil and subsoil overlying natural geology of silty clay.						Length (m)	30
						Width (m)	2
						Avg. depth (m)	0.39
Context No.	Type	Fill Of	Width (m)	Depth (m)	Description	Finds	Date
18900	Layer			0.3	Ploughsoil. Dark greyish brown clayey silt.		
18901	Layer			0.09	Subsoil. Mid yellowish brown silty clay.		
18902	Layer				Natural. Mid reddish brown silty clay.		
Trench 190							
General description						Orientation	E-W
Trench revealed two ditches. Consists of ploughsoil and subsoil overlying natural geology of silty clay.						Length (m)	30
						Width (m)	2
						Avg. depth (m)	0.48
Context No.	Type	Fill Of	Width (m)	Depth (m)	Description	Finds	Date
19000	Layer			0.36	Ploughsoil. Mid brownish grey clayey silt.		
19001	Layer			0.12	Subsoil. Mid greyish yellow silty clay.		
19002	Layer				Natural. Light yellowish brown silty clay.		
19003	Cut		1.5	0.45	Ditch		
19004	Fill	19003		0.45	Secondary Fill. Dark Greyish Brown, silty clay.		
19005	Fill	19003		0.1	Secondary Fill. Light greyish yellow, silty clay.	Pot	AD40-410
19006	Cut		1.4	0.36	Ditch		
19007	Fill	19006		0.1	Secondary Fill. Dark grey, silty clay.		
19008	Fill	19006		0.3	Secondary Fill. Light yellowish grey, silty clay.		
Trench 191							
General description						Orientation	N-S
Trench devoid of archaeology. Consists of ploughsoil and subsoil overlying natural geology of clay.						Length (m)	30
						Width (m)	2
						Avg. depth (m)	0.4
Context No.	Type	Fill Of	Width (m)	Depth (m)	Description	Finds	Date
19100	Layer			0.3	Ploughsoil. Dark brownish-grey silty clay.		
19101	Layer			0.1	Subsoil. Mid yellowish brown clay.		
19102	Layer				Natural. Mid reddish brown silty clay.		
19103	Unexcavated		1.55		Natural Feature. Geology,		

	feature				natural channel. Mottled yellowish grey silty clay with dark silty patches.		
Trench 192							
General description						Orientation	E-W
Trench revealed one ditch. Consists of ploughsoil and subsoil overlying natural geology of clay.						Length (m)	30
						Width (m)	2
						Avg. depth (m)	0.47
Context No.	Type	Fill Of	Width (m)	Depth (m)	Description	Finds	Date
19200	Layer			0.35	Ploughsoil. Mid greyish-brown clay.		
19201	Layer			0.12	Subsoil. Mid yellowish-brown clay.		
19202	Layer				Natural. Mid yellowish-grey.		
19203	Cut		0.77	0.16	Ditch		
19204	Fill	19203	0.77	0.16	Primary Fill. Med orange grey, silty clay.		
19205	Void						
Trench 193							
General description						Orientation	N-S
Trench devoid of archaeology. Consists of ploughsoil and subsoil overlying natural geology of silty clay.						Length (m)	30
						Width (m)	2
						Avg. depth (m)	0.44
Context No.	Type	Fill Of	Width (m)	Depth (m)	Description	Finds	Date
19300	Layer			0.26	Ploughsoil. Dark greyish-brown silty clay.		
19301	Layer			0.18	Subsoil. Mid reddish-brown clay.		
19302	Layer				Natural. Mid yellowish-red clay.		
Trench 194							
General description						Orientation	E-W
Trench revealed a large feature at the west. Consists of ploughsoil and subsoil overlying natural geology of clay.						Length (m)	30
						Width (m)	2
						Avg. depth (m)	0.55
Context No.	Type	Fill Of	Width (m)	Depth (m)	Description	Finds	Date
19400	Layer		2	0.3	Ploughsoil. Dark greyish brown, silty clay.		
19401	Layer		2	0.25	Subsoil. Mid reddish brown, silty clay.		
19402	Layer		2		Natural. Dark reddish brown, clay.		
19403	Cut		2	0.44	Other Cut. Large unknown feature - not bottomed		
19404	Fill	19403	1	0.2	Primary Fill. Dark blueish grey, silty clay.		
19405	Fill	19403	1.1	0.36	Secondary Fill. Dark greyish brown, silty clay.		

Trench 195							
General description						Orientation	NW-SE
Trench devoid of Archaeology. Consists of ploughsoil and subsoil overlying natural geology of silty clay.						Length (m)	30
						Width (m)	2
						Avg. depth (m)	0.44
Context No.	Type	Fill Of	Width (m)	Depth (m)	Description	Finds	Date
19500	Layer			0.34	Ploughsoil. Mid blackish brown silty clay.		
19501	Layer			0.1	Subsoil. Mid yellowish brown silty clay.		
19502	Layer				Natural. Mid reddish brown silty clay.		
Trench 196							
General description						Orientation	NE-SW
Trench revealed a single probable tree-throw. Consists of ploughsoil and subsoil overlying natural geology of silty clay.						Length (m)	30
						Width (m)	2
						Avg. depth (m)	0.5
Context No.	Type	Fill Of	Width (m)	Depth (m)	Description	Finds	Date
19600	Layer			0.35	Ploughsoil. Mid blackish brown silty clay.		
19601	Layer			0.15	Subsoil. Mid yellowish brown silty clay.		
19602	Layer				Natural. Mid reddish brown silty clay.		
19603	Cut		1.14	0.28	Probable tree-throw		
19604	Fill	19603	0.52	0.12	Primary Fill. Mid brown-greyish clayey sand.		
Trench 197							
General description						Orientation	N-S
Trench revealed one small pit. Consists of ploughsoil and subsoil overlying natural geology of clay.						Length (m)	30
						Width (m)	2
						Avg. depth (m)	0.51
Context No.	Type	Fill Of	Width (m)	Depth (m)	Description	Finds	Date
19700	Layer			0.38	Ploughsoil. Mid brownish grey clayey silt.		
19701	Layer			0.13	Subsoil. Mid greyish yellow silty clay.		
19702	Layer				Natural. Light yellowish brown silty clay.		
19703	Cut		0.74	0.2	Pit		
19704	Fill	19703	0.74	0.2	Secondary Fill. Mid greyish brown, clayey silt.		
Trench 198							
General description						Orientation	E-W
Trench devoid of archaeology. Consists of ploughsoil and subsoil overlying natural						Length (m)	30

geology of silty clay.						Width (m)	2
						Avg. depth (m)	0.53
Context No.	Type	Fill Of	Width (m)	Depth (m)	Description	Finds	Date
19800	Layer			0.38	Ploughsoil. Dark brownish-grey clayey silt.		
19801	Layer			0.15	Subsoil. Light reddish-brown clay.		
19802	Layer				Natural. Mid reddish brown silty clay.		
19803	Unexcavated feature		3.1		Natural Feature. Geology, natural channel. Mottled light greyish brown clayey silt.		
Trench 199							
General description						Orientation	N-S
Trench revealed one irregular shaped pit / tree-throw. Consists of ploughsoil and subsoil overlying natural geology of clay.						Length (m)	30
						Width (m)	2
						Avg. depth (m)	0.45
Context No.	Type	Fill Of	Width (m)	Depth (m)	Description	Finds	Date
19900	Layer			0.22	Ploughsoil. Dark greyish-brown clay.		
19901	Layer			0.23	Subsoil. Mid reddish-brown silty clay.		
19902	Layer				Natural. Mid reddish-brown clay.		
19903	Cut		1.8	2.8	Pit / tree-throw		
19904	Fill	19903	1	0.24	Primary Fill. Light bluish grey, silty clay.		
19905	Fill	19903	2.37	0.24	Secondary Fill. Dark greyish black, clay silt, frequent charcoal.	Sample <4>	
19906	Fill	19903	2.8	0.18	Tertiary Fill. Mottled reddish brown, silty clay.		
Trench 200							
General description						Orientation	E-W
Trench devoid of archaeology. Consists of ploughsoil and subsoil overlying natural geology of silty clay.						Length (m)	30
						Width (m)	2
						Avg. depth (m)	0.52
Context No.	Type	Fill Of	Width (m)	Depth (m)	Description	Finds	Date
20000	Layer			0.22	Ploughsoil. Dark greyish-brown silty clay.		
20001	Layer			0.3	Subsoil. Mid reddish-brown clay.		
20002	Layer				Natural. Light reddish-grey clay.		
Trench 201							
General description						Orientation	N-S
Trench devoid of Archaeology. Consists of ploughsoil and subsoil overlying natural geology of silty clay.						Length (m)	30
						Width (m)	2

						Avg. depth (m)	0.5
Context No.	Type	Fill Of	Width (m)	Depth (m)	Description	Finds	Date
20100	Layer			0.3	Ploughsoil. Mid greyish-brown silty clay.		
20101	Layer			0.2	Subsoil. Light reddish-brown clay.		
20102	Layer				Natural. Mid reddish-brown clay.		
Trench 202							
General description						Orientation	NE-SW
Trench devoid of Archaeology. Consists of ploughsoil and subsoil overlying natural geology of silty clay.						Length (m)	30
						Width (m)	2
						Avg. depth (m)	0.35
Context No.	Type	Fill Of	Width (m)	Depth (m)	Description	Finds	Date
20200	Layer			0.25	Ploughsoil. Mid blackish brown silty clay.		
20201	Layer			0.1	Subsoil. Mid yellowish brown silty clay.		
20202	Layer				Natural. Mid reddish brown silty clay.		
Trench 203							
General description						Orientation	NW-SE
Trench revealed one ditch. Consists of ploughsoil and subsoil overlying natural geology of silty clay.						Length (m)	30
						Width (m)	2
						Avg. depth (m)	0.4
Context No.	Type	Fill Of	Width (m)	Depth (m)	Description	Finds	Date
20300	Layer			0.29	Ploughsoil. Mid blackish brown silty clay.		
20301	Layer			0.11	Subsoil. Mid yellowish brown silty clay.		
20302	Layer				Natural. Mid reddish brown silty clay.		
20303	Cut		0.96	0.38	Ditch		
20304	Fill	20303	0.96	0.38	Primary Fill. Mid-Dark brown clayey sand.		
Trench 204							
General description						Orientation	E-W
Trench revealed two probable tree-throws. Consists of ploughsoil and subsoil overlying natural geology of silty clay.						Length (m)	30
						Width (m)	2
						Avg. depth (m)	0.44
Context No.	Type	Fill Of	Width (m)	Depth (m)	Description	Finds	Date
20400	Layer			0.35	Ploughsoil. Mid brownish grey clayey silt.		
20401	Layer			0.09	Subsoil. Mid yellowish grey silty clay.		
20402	Layer				Natural. Light brownish red silty clay.		

20403	Cut				Probable tree-throw		
20404	Fill	20403			Secondary Fill. Mid brownish grey clay.		
20405	Cut		0.88	0.38	Probable tree-throw		
20406	Fill			0.15	Other Fill. Black charcoal.	Sample <2>	
20407	Fill	20405		0.06	Secondary Fill. Light brownish grey silty clay.		
20408	Fill	20405		0.2	Secondary Fill. Mid yellowish brown silty clay.		
Trench 205							
General description						Orientation	N-S
Trench devoid of archaeology. Consists of ploughsoil and subsoil overlying natural geology of silty clay.						Length (m)	30
						Width (m)	2
						Avg. depth (m)	0.55
Context No.	Type	Fill Of	Width (m)	Depth (m)	Description	Finds	Date
20500	Layer			0.3	Ploughsoil. Mid greyish-brown silty clay		
20501	Layer			0.25	Subsoil. Mid reddish-brown silty clay		
20502	Layer				Natural. Light yellowish-red clay		
20503	Unexcavated feature		1.8		Natural Feature. Geology, natural channel. Light yellowish grey silty clay with dark silty patches.		
Trench 206							
General description						Orientation	E-W
Trench devoid of archaeology. Consists of ploughsoil and subsoil overlying natural geology of silty clay.						Length (m)	30
						Width (m)	2
						Avg. depth (m)	0.65
Context No.	Type	Fill Of	Width (m)	Depth (m)	Description	Finds	Date
20600	Layer			0.3	Ploughsoil. Mid greyish-brown.		
20601	Layer			0.35	Subsoil. Mid reddish-brown clay.		
20602	Layer				Natural. Mid reddish-grey clay.		
Trench 207							
General description						Orientation	N-S
Trench devoid of archaeology. Consists of ploughsoil and subsoil overlying natural geology of silty clay.						Length (m)	30
						Width (m)	2
						Avg. depth (m)	0.5
Context No.	Type	Fill Of	Width (m)	Depth (m)	Description	Finds	Date
20700	Layer			0.3	Ploughsoil. Mid greyish-brown silty clay.		
20701	Layer			0.2	Subsoil. Mid reddish-brown clay.		

20702	Layer				Natural. Mid yellowish-red clay.		
Trench 208							
General description						Orientation	E-W
Trench devoid of archaeology. Consists of ploughsoil and subsoil overlying natural geology of silty clay.						Length (m)	30
						Width (m)	2
						Avg. depth (m)	0.6
Context No.	Type	Fill Of	Width (m)	Depth (m)	Description	Finds	Date
20800	Layer			0.3	Ploughsoil. Mid greyish-brown silty clay.		
20801	Layer			0.3	Subsoil. Light reddish-brown clay.		
20802	Layer				Natural. Dark reddish-grey/brown with striations of mid yellow brown clay.		
Trench 209							
General description						Orientation	NW-SE
Trench devoid of archaeology. Consists of ploughsoil and subsoil overlying natural geology of silty clay.						Length (m)	30
						Width (m)	2
						Avg. depth (m)	0.32
Context No.	Type	Fill Of	Width (m)	Depth (m)	Description	Finds	Date
20900	Layer			0.2	Ploughsoil. Mid blackish brown silty clay.		
20901	Layer			0.12	Subsoil. Mid yellowish brown silty clay.		
20902	Layer				Natural. Mid reddish brown silty clay.		
20903	Cut				Natural Feature		
Trench 210							
General description						Orientation	NE-SW
Trench devoid of Archaeology. Consists of ploughsoil and subsoil overlying natural geology of silty clay.						Length (m)	30
						Width (m)	2
						Avg. depth (m)	0.38
Context No.	Type	Fill Of	Width (m)	Depth (m)	Description	Finds	Date
21000	Layer			0.3	Ploughsoil. Mid blackish brown silty clay.		
21001	Layer			0.08	Subsoil. Mid yellowish brown silty clay.		
21002	Layer				Natural. Mid reddish brown silty clay.		
21003	Void						
Trench 211							
General description						Orientation	E-W
Trench revealed one ditch. Trench consists of ploughsoil and subsoil overlying natural geology of clay.						Length (m)	30
						Width (m)	2

						Avg. depth (m)	0.43
Context No.	Type	Fill Of	Width (m)	Depth (m)	Description	Finds	Date
21100	Layer			0.32	Ploughsoil. Dark greyish black, silty clay, moderate stones		
21101	Layer			0.11	Subsoil. Med brownish yellow, silty clay, occasional stones		
21102	Layer				Natural. Med brownish yellow, silty clay, occasional chalk flecks.		
21103	Cut		2.7	0.24	Ditch		
21104	Fill	21103	2.7	0.24	Primary Fill. Mid orange brown, silty clay.		
Trench 212							
General description						Orientation	N-S
Trench devoid of archaeology. Consisted of ploughsoil and subsoil overlying natural geology of clay.						Length (m)	30
						Width (m)	2
						Avg. depth (m)	0.56
Context No.	Type	Fill Of	Width (m)	Depth (m)	Description	Finds	Date
21200	Layer			0.26	Ploughsoil. Mid greyish-brown silty clay.		
21201	Layer			0.3	Subsoil. Mid reddish-brown clay.		
21202	Layer				Natural. Light reddish-grey clay.		
21203	Cut		0.52	0.17	Natural Feature. Partial excavation of natural feature		
Trench 213							
General description						Orientation	E-W
Trench revealed one pit and two ditches. Consisted of ploughsoil and subsoil overlying natural geology of clay.						Length (m)	30
						Width (m)	2
						Avg. depth (m)	0.47
Context No.	Type	Fill Of	Width (m)	Depth (m)	Description	Finds	Date
21300	Layer			0.3	Ploughsoil. Mid greyish-brown silty clay.		
21301	Layer			0.17	Subsoil. Mid reddish-brown silty clay.		
21302	Layer				Natural. Light reddish-grey clay.		
21303	Cut		1.04	0.11	Pit		
21304	Fill	21303	1.04	0.11	Primary Fill. Mottled med orange brown, silty clay.		
21305	Cut		0.66	0.34	Ditch		
21306	Fill	21305	0.66	0.34	Primary Fill. Light bluish grey, silty clay.		
21307	Cut		0.96	0.34	Ditch		
21308	Fill	21307	0.96	0.34	Primary Fill. Mottled med brownish grey, silty clay.		
21309	Layer		2.4	0.3	Other Layer. Dark mottled		

					reddish brown, silty clay.		
Trench 214							
General description						Orientation	N-S
Trench revealed one ditch. Trench consists of ploughsoil and subsoil overlying natural silty clay geology.						Length (m)	30
						Width (m)	2
						Avg. depth (m)	0.4
Context No.	Type	Fill Of	Width (m)	Depth (m)	Description	Finds	Date
21400	Layer			0.24	Ploughsoil. Dark brownish grey sandy silt.		
21401	Layer			0.16	Subsoil. Mid reddish brown silty clay.		
21402	Layer				Natural. Mid reddish brown silty clay.		
21403	Cut		0.66	0.42	Ditch		
21404	Fill	21403	0.66	0.42	Deliberate Backfill. Mid brownish grey/ yellowish brown mottled silty clay.		
Trench 215							
General description						Orientation	E-W
Trench devoid of archaeology. Consists of ploughsoil and subsoil overlying natural silty clay geology.						Length (m)	30
						Width (m)	2
						Avg. depth (m)	0.6
Context No.	Type	Fill Of	Width (m)	Depth (m)	Description	Finds	Date
21500	Layer			0.34	Ploughsoil. Dark brownish grey clayey silt.		
21501	Layer			0.26	Subsoil. Greyish brown clay mottled with blue clay.		
21502	Layer				Natural. Mid reddish brown silty clay.		
21503	Cut				Natural Feature. Light yellowish grey silty clay.		
Trench 216							
General description						Orientation	N-S
Trench devoid of archaeology. Consists of ploughsoil and subsoil overlying a silty clay natural.						Length (m)	30
						Width (m)	2
						Avg. depth (m)	0.55
Context No.	Type	Fill Of	Width (m)	Depth (m)	Description	Finds	Date
21600	Layer			0.3	Ploughsoil. Dark brownish grey clayey silt.		
21601	Layer			0.14	Subsoil. Mid yellowish brown silty clay.		
21602	Layer			0.11	Other Layer. Mid blueish grey silty clay.		
21603	Layer				Natural. Mid yellowish grey silty clay.		
Trench 217							

General description						Orientation	E-W
Trench revealed one ditch. Trench consists of ploughsoil and subsoil overlying natural clay geology.						Length (m)	30
						Width (m)	2
						Avg. depth (m)	0.6
Context No.	Type	Fill Of	Width (m)	Depth (m)	Description	Finds	Date
21700	Layer			0.31	Ploughsoil. Dark brownish grey clayey silt.		
21701	Layer			0.29	Subsoil. Reddish brown silty clay.		
21702	Layer				Natural. Dark yellowish brown with bluish grey patches, silty clay.		
21703	Cut		0.9	0.43	Ditch		
21704	Fill	21703	0.56	0.23	Primary Fill. Light yellowish blue, silty clay.	Pot Sample <3>	LIA/ERB
21705	Fill	21703	0.9	0.27	Secondary Fill. Mid greyish brown, silty clay.		
Trench 218							
General description						Orientation	N-S
Trench revealed one ditch. Trench consists of ploughsoil and subsoil overlying natural silty clay geology.						Length (m)	30
						Width (m)	2
						Avg. depth (m)	0.54
Context No.	Type	Fill Of	Width (m)	Depth (m)	Description	Finds	Date
21800	Layer			0.37	Ploughsoil. Dark brownish grey clayey silt.		
21801	Layer			0.17	Subsoil. Reddish brown silty clay.		
21802	Layer				Natural. Mid reddish brown silty clay.		
21803	Cut		1.03	0.23	Ditch		
21804	Fill	21803	1.1	0.4	Deliberate Backfill. Mottled brownish grey/yellowish brown silty clay.	Pot	AD40-410
Trench 219							
General description						Orientation	E-W
Trench revealed one ditch. Consists of ploughsoil and subsoil overlying natural geology of silty clay.						Length (m)	30
						Width (m)	2
						Avg. depth (m)	0.54
Context No.	Type	Fill Of	Width (m)	Depth (m)	Description	Finds	Date
21900	Layer			0.35	Ploughsoil. Mid blackish brown silty clay.		
21901	Layer			0.19	Subsoil. Mod yellowish brown silty clay.		
21902	Layer				Natural. Mid reddish brown silty clay.		
21903	Cut		1.4	0.56	Ditch		
21904	Fill	21903	0.88	0.3	Deliberate Backfill. Mottled mid yellowish greyish brown silty clay.	Pot	AD40-410

21905	Fill	21903	1.4	0.26	Deliberate Backfill. Dark greyish brown silty clay.	CBM	undated
21906	Cut		1.56	0.28	Natural Feature. Probable tree-throw. Mottled greyish orangefill with evidence of rooting		
Trench 220							
General description						Orientation	N-S
Trench devoid of archaeology. Consists of ploughsoil overlying natural geology of silty clay.						Length (m)	30
						Width (m)	2
						Avg. depth (m)	0.3
Context No.	Type	Fill Of	Width (m)	Depth (m)	Description	Finds	Date
22000	Layer			0.3	Ploughsoil. Dark brownish grey clayey silt.		
22001	Layer				Natural. Mid reddish brown silty clay.		
Trench 221							
General description						Orientation	E-W
Trench devoid of archaeology. Consists of ploughsoil and subsoil overlying natural geology of silty clay.						Length (m)	30
						Width (m)	2
						Avg. depth (m)	0.4
Context No.	Type	Fill Of	Width (m)	Depth (m)	Description	Finds	Date
22100	Layer			0.32	Ploughsoil. Dark brownish grey clayey silt.		
22101	Layer			0.08	Subsoil. Mid greyish brown silty clay.		
22102	Layer				Natural. Mid bluish brown silty clay.		
Trench 222							
General description						Orientation	N-S
Trench revealed one pit. Consists of ploughsoil and subsoil overlying natural geology of silty clay.						Length (m)	30
						Width (m)	2
						Avg. depth (m)	0.5
Context No.	Type	Fill Of	Width (m)	Depth (m)	Description	Finds	Date
22200	Layer		2	0.3	Ploughsoil. Mid brownish grey clay silt.		
22201	Layer		2	0.2	Subsoil. Light brownish grey clay silt with frequent mid brownish red lenses.		
22202	Layer		2		Natural. Light greyish brown with very frequent light bluish grey and mid brownish orange lenses.		
22203	Cut		0.7	0.24	Pit		
22204	Fill	22203	0.7	0.24	Primary Fill. Midd brownish yellow, silty clay.		
Trench 223							

General description						Orientation	E-W
Trench devoid of archaeology. Consists of ploughsoil and subsoil overlying the natural clay geology.						Length (m)	30
						Width (m)	2
						Avg. depth (m)	0.45
Context No.	Type	Fill Of	Width (m)	Depth (m)	Description	Finds	Date
22300	Layer		2	0.3	Ploughsoil. Dark brownish grey clay silt.		
22301	Layer		2	0.15	Subsoil. Light greyish brown with frequent light yellowish red and occasional light bluish grey lenses.		
22302	Layer		2		Natural. Light brownish red clay silt with frequent mid bluish grey lenses and occasional light greyish green patches.		
Trench 224							
General description						Orientation	N-S
Trench devoid of archaeology. Consists of ploughsoil subsoil overlying natural geology of silty clay.						Length (m)	30
						Width (m)	2
						Avg. depth (m)	0.35
Context No.	Type	Fill Of	Width (m)	Depth (m)	Description	Finds	Date
22400	Layer			0.26	Ploughsoil. Dark greyish brown clayey silt.		
22401	Layer			0.09	Subsoil. Light greyish brown silty clay.		
22402	Layer				Natural. Mid greyish yellow silty clay.		
Trench 225							
General description						Orientation	E-W
Trench devoid of archaeology. Consists of ploughsoil overlying natural geology of sandy clay and gravel.						Length (m)	30
						Width (m)	2
						Avg. depth (m)	0.34
Context No.	Type	Fill Of	Width (m)	Depth (m)	Description	Finds	Date
22500	Layer			0.34	Ploughsoil. Dark brownish grey clayey silt.		
22501	Layer				Natural. Mid reddish brown sandy clay.		
Trench 226							
General description						Orientation	N-S
Trench revealed one ditch. Consists of ploughsoil and subsoil overlying natural geology of silty clay.						Length (m)	30
						Width (m)	2
						Avg. depth (m)	0.55
Context No.	Type	Fill Of	Width (m)	Depth (m)	Description	Finds	Date
22600	Layer			0.32	Ploughsoil. Dark brown		

					grey clayey silt.		
22601	Layer			0.23	Subsoil. Mid brownish orange silty clay.		
22602	Cut		0.95	0.12	Natural Feature. Treethrow, dark greyish brown clayey silt.		
22603	Cut		0.8	0.13	Natural Feature. Light brownish grey silty clay.		
22604	Cut		0.81	0.06	Natural Feature. Mid dark yellowish grey silty clay.		
22605	Unexcavated feature				Ditch. Possible ditch also seen in 233/239. Mottled greyish brown clayey silt.		
22606	Layer				Natural. Mid reddish brown silty clay.		
Trench 227							
General description						Orientation	E-W
Trench devoid of archaeology. Consists of ploughsoil overlying natural geology of silty clay.						Length (m)	30
						Width (m)	2
						Avg. depth (m)	0.28
Context No.	Type	Fill Of	Width (m)	Depth (m)	Description	Finds	Date
22700	Layer			0.28	Ploughsoil. Dark brownish grey clayey silt.		
22701	Layer				Natural. Mid reddish brown silty clay.		
Trench 228							
General description						Orientation	N-S
Trench devoid of archaeology. Trench consists of ploughsoil and subsoil overlying natural clay geology.						Length (m)	30
						Width (m)	2
						Avg. depth (m)	0.38
Context No.	Type	Fill Of	Width (m)	Depth (m)	Description	Finds	Date
22800	Layer		2	0.24	Ploughsoil. Dark greyish brown clayey silt.		
22801	Layer		2	0.14	Subsoil. Light greyish brown clay silt.		
22802	Layer		2		Natural. Dark brownish red silt clay with light grey lenses.		
Trench 229							
General description						Orientation	E-W
Trench devoid of archaeology. Consists of ploughsoil and subsoil overlying natural geology of silty clay.						Length (m)	30
						Width (m)	2
						Avg. depth (m)	0.55
Context No.	Type	Fill Of	Width (m)	Depth (m)	Description	Finds	Date
22900	Layer		2	0.25	Ploughsoil. Mid brownish grey clay silt.		
22901	Layer		2	0.3	Subsoil. Light brownish grey clay silt.		
22902	Layer		2		Natural. Mixed light greyish		

					brown clay silt with light bluish grey lenses and light brownish red with light bluish grey lenses.		
22903	Cut		1.27	0.14	Natural Feature. Natural linear feature, mid reddish brown silty clay.		
Trench 230							
General description						Orientation	N-S
Trench revealed two ditches. Consists of ploughsoil and subsoil overlying the natural clay geology.						Length (m)	30
						Width (m)	2
						Avg. depth (m)	0.4
Context No.	Type	Fill Of	Width (m)	Depth (m)	Description	Finds	Date
23000	Layer		2	0.3	Ploughsoil. Dark brownish grey clay silt.		
23001	Layer		2	0.1	Subsoil. Dark brownish grey clay silt with moderate dark brownish red and mid greyish brown lenses.		
23002	Layer		2		Natural. Mid brownish red silt clay with frequent mid bluish grey lenses.		
23003	Cut		0.74	0.28	Ditch		
23004	Fill	23003	0.74	0.28	Secondary Fill. Dark greyish brown clayey silt.	Peg tile	Post-med/mod
23005	Cut		0.86	0.55	Ditch		
23006	Fill	23005	0.86	0.55	Deliberate Backfill. Greyish mid brown clayey silt.		
Trench 231							
General description						Orientation	E-W
Trench revealed one ditch. Consists of ploughsoil and subsoil overlying natural geology of silty clay.						Length (m)	30
						Width (m)	2
						Avg. depth (m)	0.4
Context No.	Type	Fill Of	Width (m)	Depth (m)	Description	Finds	Date
23100	Layer			0.32	Ploughsoil. Mid brownish grey clayey silt.		
23101	Layer			0.08	Subsoil. Mid yellowish grey silty clay.		
23102	Layer				Natural. Light yellowish brown silty clay.		
23103	Unexcavated feature				Ditch. SW-NE. Dark greyish brown silty clay.		
Trench 232							
General description						Orientation	N-S
Trench devoid of archaeology. Consists of ploughsoil overlying natural geology of sandy clay.						Length (m)	30
						Width (m)	2
						Avg. depth (m)	0.32
Context No.	Type	Fill Of	Width (m)	Depth (m)	Description	Finds	Date

23200	Layer			0.32	Ploughsoil. Dark brownish grey clayey silt.		
23201	Layer				Natural. Mid reddish brown sandy clay.		
Trench 233							
General description						Orientation	E-W
Trench revealed four ditches. Comprises of ploughsoil, subsoil and natural clay deposits.						Length (m)	30
						Width (m)	2
						Avg. depth (m)	0.4
Context No.	Type	Fill Of	Width (m)	Depth (m)	Description	Finds	Date
23300	Layer			0.33	Ploughsoil. Dark grey clayey silt.		
23301	Layer			0.07	Subsoil. Dark brownish grey clayey silt.		
23302	Layer				Natural. Mid reddish brown sandy clay.		
23303	Cut		1.27	0.44	Ditch		
23304	Fill	23303	1.27	0.44	Primary Fill. Dark brownish grey clayey silt.	Tile and brick	Post-med/mod
23305	Cut		0.8	0.6	Ditch		
23306	Fill	23305	0.8	0.6	Primary Fill. Mottled greyish/reddish brown, silty clay.		
23307	Cut		2	0.18	Ditch		
23308	Fill	23307	1.78	0.2	Primary Fill. Dark to mid mottled greyish brown, silty clay.		
23309	Fill	23307	2.52	0.2	Primary Fill. Mid greyish orange silty clay.		
23310	Fill	23307	1.3	0.1	Primary Fill. Light yellowish brown, silty clay.		
Trench 234							
General description						Orientation	N-S
Trench revealed two ditches. Consists of ploughsoil overlying natural geology of silty clay.						Length (m)	30
						Width (m)	2
						Avg. depth (m)	0.3
Context No.	Type	Fill Of	Width (m)	Depth (m)	Description	Finds	Date
23400	Layer			0.3	Ploughsoil. Dark greyish brown clayey silt.		
23401	Layer				Natural. Mid bluish brown silty clay.		
23402	Unexcavated feature		1.2		Ditch. Boundary ditch as seen on OS map. Irregular on s side possible hedge line. Dark greyish brown clayey silt.		
23403	Unexcavated feature		0.3		Ditch. Boundary ditch. Possibly related to the one shown on the OS map. Dark blackish brown clayey silt.		
Trench 235							

General description						Orientation	E-W
Trench revealed two ditches. Trench comprised ploughsoil and subsoil over natural clay geology.						Length (m)	30
						Width (m)	2
						Avg. depth (m)	0.5
Context No.	Type	Fill Of	Width (m)	Depth (m)	Description	Finds	Date
23500	Layer		2	0.3	Ploughsoil. Mid brownish grey clay silt.		
23501	Layer		2	0.2	Subsoil. Light greyish brown clay silt.		
23502	Layer		2		Natural. Dark greyish brown clay silt.		
23503	Cut		0.4	0.35	Ditch		
23504	Fill	23503	0.4	0.35	Primary Fill. Mid greyish-brown clay.		
23505	Cut		1.75	0.31	Ditch		
23506	Fill		1.75	0.31	Secondary Fill. Dark greyish brown silty clay.	Flint Glass	Modern
Trench 236							
General description						Orientation	N-S
Trench devoid of archaeology. Trench consists of ploughsoil and subsoil overlying the natural clay geology.						Length (m)	30
						Width (m)	2
						Avg. depth (m)	0.45
Context No.	Type	Fill Of	Width (m)	Depth (m)	Description	Finds	Date
23600	Layer		2	0.25	Ploughsoil. Mid brownish grey clay silt.		
23601	Layer		2	0.2	Subsoil. Light brownish orange clay silt with light grey lenses.		
23602	Layer		2		Natural. Light bluish grey clay silt with very frequent light brownish orange lenses.		
Trench 237							
General description						Orientation	E-W
Trench devoid of archaeology. Trench consists of ploughsoil and subsoil overlying the natural clay geology.						Length (m)	30
						Width (m)	2
						Avg. depth (m)	0.45
Context No.	Type	Fill Of	Width (m)	Depth (m)	Description	Finds	Date
23700	Layer		2	0.25	Ploughsoil. Dark brownish grey clay silt.		
23701	Layer		2	0.2	Subsoil. Mid yellowish brown clay silt with frequent dark greyish brown, light bluish grey and dark brownish red lenses.		
23702	Layer		2		Natural. Light brownish orange clay silt with frequent light bluish grey and dark brownish red lenses.		

Trench 238							
General description						Orientation	N-S
Trench devoid of archaeology. Trench consists of ploughsoil and subsoil overlying the natural clay geology.						Length (m)	30
						Width (m)	2
						Avg. depth (m)	0.5
Context No.	Type	Fill Of	Width (m)	Depth (m)	Description	Finds	Date
23800	Layer		2	0.3	Ploughsoil. Dark brownish grey clay silt.		
23801	Layer		2	0.2	Subsoil. Dark brownish yellow with frequent dark brownish grey lenses.		
23802	Layer		2		Natural. Dark brownish yellow clay silt with moderate patches of yellow and light bluish grey silty clay.		
Trench 239							
General description						Orientation	E-W
Trench revealed two ditches. Consists of plough soil and sub soil overlaying a natural clay geology.						Length (m)	30
						Width (m)	2
						Avg. depth (m)	0.52
Context No.	Type	Fill Of	Width (m)	Depth (m)	Description	Finds	Date
23900	Layer			0.34	Ploughsoil. Mid greyish brown clayey silt.		
23901	Layer			0.18	Subsoil. Dark yellowish brown silty clay.		
23902	Layer				Natural. Mid brownish orange silty clay.		
23903	Unexcavated feature				Ditch. Mottled bluish grey and brown clayey silt.		
23904	Unexcavated feature			0.72	Ditch. OS map boundary ditch. Dark greyish brown clayey silt.		
Trench 240							
General description						Orientation	N-S
Trench devoid of archaeology. Consists of ploughsoil and subsoil overlying natural geology of silty clay.						Length (m)	30
						Width (m)	2
						Avg. depth (m)	0.44
Context No.	Type	Fill Of	Width (m)	Depth (m)	Description	Finds	Date
24000	Layer			0.3	Ploughsoil. Dark greyish brown clayey silt.		
24001	Layer			0.14	Subsoil. Mid greyish brown silty clay.		
24002	Layer				Natural. Mid yellowish brown silty clay.		
Trench 241							
General description						Orientation	E-W

Trench devoid of archaeology. Consists of ploughsoil and subsoil overlying natural clay.						Length (m)	30
						Width (m)	2
						Avg. depth (m)	0.46
Context No.	Type	Fill Of	Width (m)	Depth (m)	Description	Finds	Date
24100	Layer		2	0.36	Topsoil. Mid brownish grey clay silt.		
24101	Layer		2	0.16	Subsoil. Light greyish brown clay silt.		
24102	Layer		2	0.45	Natural. Light brownish red silt clay with light bluish grey silt clay lenses.		
24103	Cut				Natural Feature		
Trench 242							
General description						Orientation	N-S
Trench devoid of archaeology. Consisted of ploughsoil and subsoil overlying the natural clay geology.						Length (m)	30
						Width (m)	2
						Avg. depth (m)	0.45
Context No.	Type	Fill Of	Width (m)	Depth (m)	Description	Finds	Date
24200	Layer		2	0.25	Ploughsoil. Mid brownish grey clay silt.		
24201	Layer		2	0.2	Subsoil. Light grey clay silt.		
24202	Layer		2		Natural. Light brownish red silt clay with frequent light grey lenses and light greyish brown patches.		
Trench 243							
General description						Orientation	E-W
Trench devoid of archaeology. Trench consists of ploughsoil and subsoil overlying natural clay geology.						Length (m)	30
						Width (m)	2
						Avg. depth (m)	0.45
Context No.	Type	Fill Of	Width (m)	Depth (m)	Description	Finds	Date
24300	Layer		2	0.35	Ploughsoil. Mid greyish brown clay silt.		
24301	Layer		3	0.1	Subsoil. Mid brownish grey with frequent light brownish red lenses.		
24302	Layer		2		Natural. Light brownish red silt clay with light grey lenses.		
Trench 244							
General description						Orientation	N-S
Trench devoid of archaeology. Trench consists of ploughsoil and subsoil overlying the natural clay geology.						Length (m)	30
						Width (m)	2
						Avg. depth (m)	0.45
Context No.	Type	Fill Of	Width (m)	Depth (m)	Description	Finds	Date

24400	Layer		2	0.3	Ploughsoil. Dark bluish grey silty clay with occasional dark brownish red lenses.		
24401	Layer		2	0.15	Subsoil. Light brownish grey clay silt with frequent light bluish grey and light brownish orange lenses.		
24402	Layer		2		Natural. Light bluish grey silt clay with very frequent light yellowish red lenses.		
Trench 245							
General description						Orientation	E-W
Trench devoid of archaeology. Trench consists of ploughsoil and subsoil overlying natural clay geology.						Length (m)	30
						Width (m)	2
						Avg. depth (m)	0.5
Context No.	Type	Fill Of	Width (m)	Depth (m)	Description	Finds	Date
24500	Layer		2	0.3	Ploughsoil. Dark brownish grey clay silt with frequent dark brownish red and dark bluish grey lenses.		
24501	Layer		2	0.2	Subsoil. Dark yellowish brown clay silt with frequent dark greyish brown lenses.		
24502	Layer		2		Natural. Mixed dark yellowish brown and dark greyish brown silty clay with frequent light bluish grey lenses.		
Trench 246							
General description						Orientation	NE-SW
Trench devoid of archaeology. Consists of plough soil and sub soil overlaying a the natural clay geology.						Length (m)	30
						Width (m)	2
						Avg. depth (m)	0.38
Context No.	Type	Fill Of	Width (m)	Depth (m)	Description	Finds	Date
24600	Layer			0.29	Ploughsoil. Dark greyish brown clayey silt.		
24601	Layer			0.09	Subsoil. Light yellowish brown clayey silt.		
24602	Layer				Natural. Mid yellowish red silty clay.		
Trench 247							
General description						Orientation	E-W
Trench devoid of archaeology. Consists of ploughsoil and subsoil overlying natural geology of silty clay.						Length (m)	30
						Width (m)	2
						Avg. depth (m)	0.45
Context No.	Type	Fill Of	Width (m)	Depth (m)	Description	Finds	Date
24700	Layer			0.34	Ploughsoil. Dark greyish brown clayey silt.		

24701	Layer			0.11	Subsoil. Mid yellowish brown silty clay.		
24702	Layer				Natural. Mid bluish red silty clay.		
Trench 248							
General description						Orientation	N-S
Trench devoid of archaeology. Consisted of ploughsoil and subsoil overlying the natural geology of clay.						Length (m)	30
						Width (m)	2
						Avg. depth (m)	0.4
Context No.	Type	Fill Of	Width (m)	Depth (m)	Description	Finds	Date
24800	Layer		2	0.25	Ploughsoil. Dark greyish brown clayey silt.		
24801	Layer		2	0.15	Subsoil. Light brownish grey clay silt.		
24802	Layer		2		Natural. Light brownish red silt clay with light greyish green clay silt lenses.		
Trench 249							
General description						Orientation	NW-SE
Trench devoid of archaeology. Consisted of ploughsoil and subsoil overlying the natural geology of clay.						Length (m)	30
						Width (m)	2
						Avg. depth (m)	0.5
Context No.	Type	Fill Of	Width (m)	Depth (m)	Description	Finds	Date
24900	Layer		2	0.35	Topsoil. Mid brownish grey clay silt.		
24901	Layer		2	0.15	Subsoil. Light yellowish brown clay silt with dark brownish red and light grey lenses.		
24902	Layer		2		Natural. Light brownish grey clay silt with light brownish red and light grey lenses.		
24903	Cut		2.3	0.12	Natural Feature. Possible natural depression.		
24904	Cut		1.5	0.24	Natural Feature. Circular geology.		
Trench 250							
General description						Orientation	E-W
Trench revealed three cultivation ditches. Consists of plough soil and subsoil overlaying a clay geology.						Length (m)	30
						Width (m)	2
						Avg. depth (m)	0.48
Context No.	Type	Fill Of	Width (m)	Depth (m)	Description	Finds	Date
25000	Layer				Natural. Light yellowish brown. Silty clay.		
25001	Layer			0.2	Subsoil. Light yellowish brown clay silt.		
25002	Layer			0.28	Ploughsoil. Dark reddish brown silty.		

25003	Cut		1.02	0.46	Ditch		
25004	Fill	25003	1.02	0.46	Deliberate Backfill. Mid brownish grey sandy clay.		
25005	Cut		0.87	0.36	Ditch		
25006	Fill	25005	0.87	0.36	Deliberate Backfill. Mid bluish grey silty clay.	Pot Sample <1>	LIA/ERB
25007	Cut		1.03	0.36	Ditch		
25008	Fill	25007	1.03	0.36	Deliberate Backfill. Mid bluish grey and yellowish brown mottled silty clay.		

Trench 251

General description						Orientation	NW-SE
Trench devoid of archaeology. Consists of ploughsoil and subsoil overlying natural geology of silty clay.						Length (m)	30
						Width (m)	2
						Avg. depth (m)	0.39
Context No.	Type	Fill Of	Width (m)	Depth (m)	Description	Finds	Date
25100	Layer			0.28	Ploughsoil. Dark greyish brown clayey silt.		
25101	Layer			0.11	Subsoil. Mid greyish brown silty clay.		
25102	Layer				Natural. Mid reddish brown silty clay.		

Trench 252

General description						Orientation	NE-SW
Trench devoid of archaeology. Consists of plough soil and subsoil overlaying a clay geology.						Length (m)	30
						Width (m)	2
						Avg. depth (m)	0.42
Context No.	Type	Fill Of	Width (m)	Depth (m)	Description	Finds	Date
25200	Layer			0.3	Ploughsoil. Dark greyish brown clayey silt.		
25201	Layer			0.12	Subsoil. Dark yellowish brown silty clay.		
25202	Layer				Ploughsoil. Light blueish red silty clay.		

Trench 253

General description						Orientation	E-W
Trench revealed one ditch. Consists of ploughsoil and subsoil overlying natural clay.						Length (m)	30
						Width (m)	2
						Avg. depth (m)	0.46
Context No.	Type	Fill Of	Width (m)	Depth (m)	Description	Finds	Date
25300	Layer		2	0.3	Ploughsoil. Dark greyish brown, silty clay.		
25301	Layer		2	0.16	Subsoil. Mid yellowish brown, silty clay.		
25302	Layer		2		Natural. Dark reddish brown, clay and gravel patches.		

25303	Cut		0.67	0.31	Ditch		
25304	Fill	25303	0.54	0.15	Primary Fill. Mid greyish blue, silty clay.		
25305	Fill	25303	0.67	0.11	Secondary Fill. Mid brownish yellow, silty clay.		
25306	Cut	25306	0.48	0.08	Natural Feature		
25307	Cut	25307	1.09	0.06	Natural Feature		
25308	Cut	25308	0.87	0.05	Natural Feature		
Trench 254							
General description						Orientation	N-S
Trench revealed a single ditch. Consists of ploughsoil and subsoil overlying natural clay.						Length (m)	30
						Width (m)	2
						Avg. depth (m)	0.5
Context No.	Type	Fill Of	Width (m)	Depth (m)	Description	Finds	Date
25400	Layer			0.35	Ploughsoil. Dark greyish brown, silty clay.		
25401	Layer			0.15	Subsoil. Mid yellowish brown, silty clay.		
25402	Layer				Natural. Dark reddish brown, clay and gravel patches.		
25403	Cut		0.95	0.22	Ditch		
25404	Fill	25403	0.95	0.22	Primary Fill. Dark greyish brown, silty clay.	Iron object	Post-med/mod
Trench 255							
General description						Orientation	E-W
Trench revealed one ditch. Consists of ploughsoil and subsoil overlying natural clay.						Length (m)	30
						Width (m)	2
						Avg. depth (m)	0.45
Context No.	Type	Fill Of	Width (m)	Depth (m)	Description	Finds	Date
25500	Layer			0.3	Ploughsoil. Dark greyish brown silty clay		
25501	Layer			0.15	Subsoil. Mid yellowish brown silty clay		
25502	Layer				Natural. Dark reddish brown clay		
25503	Cut		0.65	0.42	Ditch		
25504	Fill	25503	0.65	0.42	Primary Fill. Mid brownish grey, silty clay.		
Trench 256							
General description						Orientation	N-S
Trench devoid of archaeology. Consists of ploughsoil and subsoil overlying natural clay.						Length (m)	30
						Width (m)	2
						Avg. depth (m)	0.23
Context No.	Type	Fill Of	Width (m)	Depth (m)	Description	Finds	Date
25600	Layer			0.23	Ploughsoil. Mid greyish brown sandy silt.		

25601	Layer				Natural. Light yellowish-brown sandy clay, frequent gravel-like inclusions.		
25602	Cut		1.3	0.09	Natural Feature. Greyish brown silty clay.		
Trench 257							
General description						Orientation	E-W
Trench devoid of archaeology. Consists of ploughsoil which overlies a natural of mid yellowish-brown sandy clay with gravel.						Length (m)	30
						Width (m)	2
						Avg. depth (m)	0.3
Context No.	Type	Fill Of	Width (m)	Depth (m)	Description	Finds	Date
25700	Layer			0.3	Ploughsoil. Mid greyish-brown sandy silt.		
25701	Void						
25702	Layer				Natural. Light yellowish-brown sandy clay.		
25703	Cut		0.48	0.09	Natural Feature. Light grey silty clay.		
25704	Cut		0.82	0.14	Natural Feature. Possible tree-throw. Irregularly-shaped. Mid greyish brown silty clay.		
25705	Cut		0.72	0.09	Natural Feature. Possible tree-throw. Irregularly-shaped. Mid bluish-grey silty clay.		
Trench 258							
General description						Orientation	N-S
Trench devoid of archaeology. Consists of ploughsoil and subsoil overlying natural clay.						Length (m)	30
						Width (m)	2
						Avg. depth (m)	0.45
Context No.	Type	Fill Of	Width (m)	Depth (m)	Description	Finds	Date
25800	Layer			0.45	Ploughsoil. Mid greyish-brown silty clay.		
25801	Layer				Natural. Mid reddish-brown silty clay.		
25802	Cut		1.05	0.36	Natural Feature. Mid reddish brown, clay.		
25803	Cut	25803	0.6	0.12	Natural Feature. Mid greyish yellow, gravelly sand.		
25804	Cut	25804	0.58		Natural Feature. Circular, Mid greyish yellow, gravelly sand.		
Trench 259							
General description						Orientation	E-W
Trench revealed one ditch. Consists of ploughsoil overlying natural geology of silty clay.						Length (m)	30
						Width (m)	2
						Avg. depth (m)	0.37
Context	Type	Fill Of	Width	Depth	Description	Finds	Date

No.			(m)	(m)			
25900	Layer			0.35	Ploughsoil. Mid greyish-brown silty clay.		
25901	Layer			0.02	Subsoil. Mid reddish-brown silty clay.		
25902	Layer				Natural. Light reddish-brown and yellow silty clay.		
25903	Cut		0.67	0.18	Ditch		
25904	Fill	25903	0.67	0.18	Secondary Fill. Yellowish brown clayey silt.		
Trench 260							
General description						Orientation	N-S
Trench devoid of archaeology. Consists of ploughsoil and subsoil overlying natural clay.						Length (m)	30
						Width (m)	2
						Avg. depth (m)	0.49
Context No.	Type	Fill Of	Width (m)	Depth (m)	Description	Finds	Date
26000	Layer			0.4	Ploughsoil. Dark greyish brown, silty clay.		
26001	Layer			0.09	Subsoil. Mid yellowish brown, silty clay.		
26002	Layer				Natural. Dark reddish brown, clay with sand patches.		
Trench 261							
General description						Orientation	E-W
Trench devoid of archaeology. Consists of ploughsoil and subsoil overlying natural clay.						Length (m)	30
						Width (m)	2
						Avg. depth (m)	0.42
Context No.	Type	Fill Of	Width (m)	Depth (m)	Description	Finds	Date
26100	Layer			0.3	Ploughsoil. Dark greyish brown, silty clay.		
26101	Layer			0.12	Subsoil. Mid yellowish brown, silty clay.		
26102	Layer				Natural. Dark reddish brown, silty clay.		
Trench 262							
General description						Orientation	N-S
Trench devoid of archaeology. Consists of ploughsoil and subsoil overlying natural clay.						Length (m)	30
						Width (m)	2
						Avg. depth (m)	0.35
Context No.	Type	Fill Of	Width (m)	Depth (m)	Description	Finds	Date
26200	Layer			0.3	Ploughsoil. Dark greyish brown silty clay		
26201	Layer			0.05	Subsoil. Mid yellowish brown silty clay		
26202	Layer				Natural. Dark reddish brown clay		

Trench 263							
General description						Orientation	E-W
Trench devoid of any archaeology. Consists of ploughsoil and subsoil overlying natural clay.						Length (m)	30
						Width (m)	2
						Avg. depth (m)	0.36
Context No.	Type	Fill Of	Width (m)	Depth (m)	Description	Finds	Date
26300	Layer			0.29	Ploughsoil. Mid greyish brown. Clayey silt		
26301	Layer			0.07	Subsoil. Light yellowish brown. Silty clay.		
26302	Layer				Natural. Mid reddish brown silty clay with gravel.		
Trench 264							
General description						Orientation	N-S
Trench devoid of Archaeology. Consists of ploughsoil and subsoil overlying natural clay.						Length (m)	30
						Width (m)	2
						Avg. depth (m)	0.4
Context No.	Type	Fill Of	Width (m)	Depth (m)	Description	Finds	Date
26400	Layer			0.36	Ploughsoil. Mid greyish-brown silty clay.		
26401	Layer			0.04	Subsoil. Mid yellowish-brown silty clay.		
26402	Layer				Natural. Light yellowish-red silty clay.		
Trench 265							
General description						Orientation	E-W
Trench revealed one ditch. Consists of ploughsoil and subsoil overlying natural clay.						Length (m)	30
						Width (m)	2
						Avg. depth (m)	0.3
Context No.	Type	Fill Of	Width (m)	Depth (m)	Description	Finds	Date
26500	Layer			0.3	Ploughsoil. Mid greyish-brown silty clay.		
26501	Layer				Natural. Light yellowish brown silty clay.		
26502	Cut	26502	1		Natural Feature		
26503	Cut		0.88	0.36	Ditch		
26504	Fill	26503	0.64	0.22	Primary Fill. Mid brownish grey, silty clay.		
26505	Fill	26503	0.88	0.15	Secondary Fill. Mid brownish red, silty clay.	Pot	AD40-410
Trench 266							
General description						Orientation	N-S
Trench revealed one ditch. Consists of ploughsoil and subsoil overlying natural clay.						Length (m)	30
						Width (m)	2
						Avg. depth (m)	0.4

Context No.	Type	Fill Of	Width (m)	Depth (m)	Description	Finds	Date
26600	Layer			0.4	Ploughsoil. Mid greyish-brown silty clay.		
26601	Layer				Natural. Light reddish-brown clay.		
26602	Cut		0.95	0.4	Ditch		
26603	Fill	26602	0.95	0.4	Secondary Fill. Yellowish brown clayey silt.		
Trench 267							
General description						Orientation	E-W
Trench revealed one ditch. Consists of ploughsoil and subsoil overlying natural clay.						Length (m)	30
						Width (m)	2
						Avg. depth (m)	0.55
Context No.	Type	Fill Of	Width (m)	Depth (m)	Description	Finds	Date
26700	Layer			0.35	Ploughsoil. Dark greyish brown, silty clay.		
26701	Layer			0.2	Subsoil. Mid yellowish brown, silty clay.		
26702	Layer				Natural. Dark reddish brown, clay.		
26703	Cut		0.63	0.14	Ditch		
26704	Fill	26703	0.63	0.14	Primary Fill. Mid yellow brown, silty clay.		
Trench 268							
General description						Orientation	N-S
Trench devoid of archaeology. Consists of ploughsoil and subsoil overlying natural clay.						Length (m)	30
						Width (m)	2
						Avg. depth (m)	0.47
Context No.	Type	Fill Of	Width (m)	Depth (m)	Description	Finds	Date
26800	Layer			0.35	Ploughsoil. Dark greyish brown, silty clay.		
26801	Layer			0.12	Subsoil. Mid yellowish brown, silty clay.		
26802	Layer				Natural. Dark reddish brown, clay.		
26803	Void						
Trench 269							
General description						Orientation	E-W
Trench devoid of archaeology. Consists of ploughsoil and subsoil overlying natural clay.						Length (m)	30
						Width (m)	2
						Avg. depth (m)	0.37
Context No.	Type	Fill Of	Width (m)	Depth (m)	Description	Finds	Date
26900	Layer			0.3	Ploughsoil. Dark greyish brown, silty clay.	Flint	
26901	Layer			0.07	Subsoil. Mid yellowish brown, silty clay.		
26902	Layer				Natural. Dark reddish		

					brown, clay.		
26903	Cut				Natural Feature		
26904	Cut				Natural Feature		
26905	Cut				Natural Feature		
26906	Cut				Natural Feature		
Trench 270							
General description						Orientation	N-S
Trench devoid of archaeology. Consists of ploughsoil and subsoil overlying the natural geology of sandy clay.						Length (m)	30
						Width (m)	2
						Avg. depth (m)	0.48
Context No.	Type	Fill Of	Width (m)	Depth (m)	Description	Finds	Date
27000	Layer			0.32	Ploughsoil. Mid greyish brown. Clayey silt.		
27001	Layer			0.16	Subsoil. Light yellowish brown. Silty clay.		
27002	Layer				Natural. Dark reddish brown. Silty clay with gravel inclusions.		
27003	Cut				Natural Feature		
Trench 271							
General description						Orientation	E - W
Trench devoid of archaeology. Consisted of ploughsoil and subsoil overlying the geology of clay.						Length (m)	30
						Width (m)	2
						Avg. depth (m)	0.42
Context No.	Type	Fill Of	Width (m)	Depth (m)	Description	Finds	Date
27100	Layer			0.3	Ploughsoil. Mid greyish brown. Clayey silt.		
27101	Layer			0.12	Subsoil. Light yellowish brown. Silty clay.		
27102	Layer				Natural. Mid reddish brown. Silty clay.		
Trench 272							
General description						Orientation	N-S
Trench devoid of Archaeology. Consists of ploughsoil and subsoil overlying natural clay.						Length (m)	30
						Width (m)	2
						Avg. depth (m)	0.4
Context No.	Type	Fill Of	Width (m)	Depth (m)	Description	Finds	Date
27200	Layer			0.35	Ploughsoil. Mid greyish-brown silty clay.		
27201	Layer			0.05	Subsoil. Mid reddish-brown silty clay.		
27202	Layer				Natural. Light yellowish red silty clay.		
Trench 273							

General description						Orientation	E-W
Trench revealed two ditches. Consists of ploughsoil and subsoil overlying natural geology.						Length (m)	30
						Width (m)	2
						Avg. depth (m)	0.6
Context No.	Type	Fill Of	Width (m)	Depth (m)	Description	Finds	Date
27300	Layer			0.4	Ploughsoil. Mid greyish-brown silty clay.		
27301	Layer			0.2	Subsoil. Mid reddish-brown silty clay.		
27302	Layer				Natural. Light reddish-brown and yellowish-brown silty clay.		
27303	Cut		0.94	0.19	Ditch		
27304	Fill	27303	0.94	0.29	Deliberate Backfill. Light greyish brown, silty clay.		
27305	Cut		0.65	0.3	Ditch		
27306	Fill		0.65	0.3	Secondary Fill. Light yellowish brown silty sand.		
Trench 274							
General description						Orientation	N-S
Trench devoid of archaeology. Consists of ploughsoil and subsoil overlying natural clay.						Length (m)	30
						Width (m)	2
						Avg. depth (m)	0.44
Context No.	Type	Fill Of	Width (m)	Depth (m)	Description	Finds	Date
27400	Layer		2	0.3	Ploughsoil. Dark greyish brown, silty clay.		
27401	Layer		2	0.14	Subsoil. Mid yellowish brown, silty clay.		
27402	Layer		2		Natural. Dark reddish brown, clay and gravel patches.		
27403	Cut				Natural Feature		
27404	Fill	27403			Other Fill. Mid greyish brown silty clay.	Pot Fired clay	LIA/ERB undated
Trench 275							
General description						Orientation	E-W
Trench devoid of archaeology. Consists of ploughsoil and subsoil overlying natural clay and gravel patches.						Length (m)	30
						Width (m)	2
						Avg. depth (m)	0.47
Context No.	Type	Fill Of	Width (m)	Depth (m)	Description	Finds	Date
27500	Layer			0.35	Ploughsoil. Dark greyish brown, silty clay.		
27501	Layer			0.12	Subsoil. Mid yellowish brown, silty clay.		
27502	Layer				Natural. Dark reddish brown, clay.		
Trench 276							
General description						Orientation	N-S

Trench revealed one ditch. Consists of ploughsoil overlying natural geology of clay.						Length (m)	30
						Width (m)	2
						Avg. depth (m)	0.34
Context No.	Type	Fill Of	Width (m)	Depth (m)	Description	Finds	Date
27600	Layer			0.34	Ploughsoil. Dark greyish brown clayey silt.		
27601	Layer				Natural. Mid reddish brown silty clay.		
27602	Cut	27602			Natural Feature. Dark grey silty clay.		
27603	Cut		0.5	0.58	Ditch		
27604	Fill	27603	0.5	0.58	Secondary Fill. Mid greyish brown sandy clay.		
Trench 277							
General description						Orientation	E-W
Trench devoid of archaeology. Consists of ploughsoil and subsoil overlying natural geology of clay.						Length (m)	30
						Width (m)	2
						Avg. depth (m)	0.46
Context No.	Type	Fill Of	Width (m)	Depth (m)	Description	Finds	Date
27700	Layer			0.37	Ploughsoil. Dark greyish brown, silty clay.		
27701	Layer			0.09	Subsoil. Mid greyish yellow, silty clay.		
27702	Layer				Natural. Mid orange yellow, clay.		
27703	Cut				Natural Feature		
Trench 278							
General description						Orientation	N-S
Trench devoid of archaeology. Consists of ploughsoil and subsoil overlying natural geology of clay.						Length (m)	30
						Width (m)	2
						Avg. depth (m)	0.42
Context No.	Type	Fill Of	Width (m)	Depth (m)	Description	Finds	Date
27800	Layer			0.32	Ploughsoil. Dark greyish brown, silty clay.		
27801	Layer			0.1	Subsoil. Mid brownish yellow, silty clay.		
27802	Layer				Natural. Mid orange yellow, clay with patches of sandy gravel.		

Appendix B Finds Reports

B.1 Pottery

By Pete Banks

Introduction

B.1.1 A total of 22 sherds (104g) of pottery were recovered from the evaluation. The pottery has been recorded direct to an Excel spreadsheet from which Appendix B (Table 1) is derived and which forms part of the project archive. The pottery was examined by context, using a x10 binocular microscope. The fabrics are described in accordance with the Historic England guidelines (Barclay *et al.* 2016) and the Prehistoric Ceramics Research Group guidelines (PCRG 2010). Late Iron Age and Roman pottery fabrics were assigned codes from OA's standard recording system for material of that date (Booth 2019). Forms identified by rim were given codes from OA's system. A concordance with the Essex fabric series classified by Chelmsford Archaeological Trust (Biddulph *et.al.* 2015) and Going's (1987) type series of pottery from Chelmsford have been provided where possible.

B.1.2 Each context-group was quantified by sherd count and weight (grammes), and any rims present were additionally quantified by estimated vessel equivalent (EVE), which measures the percentage of rim circumference that survives (thus, 0.3 equals 30%). The total was 0.05 EVEs from a minimum of one vessel identified by rim (MNV). Pottery data by context is provided in Table 1.

B.1.3 The following Late Iron Age and Roman fabrics were noted (NRFRC codes in brackets):

- C10 Shell-tempered ware
- E30 Late Iron Age/early Roman medium sand tempered fabrics
- E80 Late Iron Age/early Roman grog-tempered ware (SOB GT)
- E810 Late Iron Age/early Roman grog and sand tempered fabrics
- O14 Fine micaceous sandy oxidised ware
- O20 Sandy oxidised ware
- R10 Fine reduced ware
- R30 Medium sandy reduced ware
- R31 Sandy and organic reduced ware
- R60 Sandy reduced ware with organic inclusions. Poss. E10?
- E40 Early shell-tempered ware

B.1.4 The following form identified by rim was recorded (Type series from Going 1987 in brackets):

- HB Straight sided bowl (B4)

Ctxt	Count	Wt (g)	MNV	EVEs	Fabric Code	Essex Fabric Series	Comments	Spot-date
17406	2	4	0	0	R31		Organic and sandy reduced ware	AD40-410
18104	5	15	1	0.05	R30	GRS	Sandy grey ware, (HB/B4) Straight-sided bowl with beaded rim.	AD140-250
18108	1	11	0	0	R30	GRS	Sandy grey ware	AD40-410

Ctxt	Count	Wt (g)	MNV	EVEs	Fabric Code	Essex Fabric Series	Comments	Spot-date
18108	1	1	0	0	O14	REDM	Sandy micaceous oxidised ware	AD40-410
18108	1	2	0	0	E810	GROG	Sandy grog-tempered ware	LIA/ERB
19005	2	6	0	0	C10		Shell-tempered ware	AD40-410
19005	1	3	0	0	R30	GRS	Sandy grey ware	AD40-410
19005	1	3	0	0	R31		Organic and sandy reduced ware	AD40-410
21704	1	6	0	0	E80	GROG	Grog-tempered ware	LIA/ERB
21804	1	3	0	0	O20	RED	Sandy oxidised ware	AD40-410
21904	1	30	0	0	R10	GRF	Sandy micaceous grey ware	AD40-410
25006	1	6	0	0	E810	GROG	Sandy grog-tempered ware	LIA/ERB
25006	2	3	0	0	E30		LIA/ERB Early sandy ware	LIA/ERB
26505	1	5	0	0	O14	REDM	Sandy micaceous oxidised ware	AD40-410
27404	1	6	0	0	E40	ESH	Early shell-tempered ware	LIA/ERB

Table 1: Summary and quantification of the pottery by context

Key: EVE estimated vessel equivalent; MNV minimum number of vessels; LIA/ERB late Iron Age/early Roman

Late Iron Age to early Roman

- B.1.5 A small group of pottery (6 sherds 23g) could be dated to the late Iron Age or early Roman period. Material dating to this period was recovered from Trenches 181, 217, 250 and 274. All were small groups weighing less than 10g. The late Iron Age to early Roman assemblage included sand (E30), grog (E80), shell (E40) and sand and grog-tempered (E810) fabrics. The group comprised unfeatured body sherds.

Middle Roman

- B.1.6 Ditch 18103 (Trench 181) produced a small group (5 sherds; 15g) of sandy grey wares (R30). Within this group was the rim sherd from a straight-sided bowl/dish with a small, beaded rim (B4; 0.05 EVEs); the only form recorded. This vessel dates to between the mid-2nd to mid-3rd centuries AD (Going 1987, 15).

Roman

- B.1.7 A total of 11 featureless body sherds (66g) could be broadly dated to the Roman period. Roman fabrics consisted of oxidised (O14/O20) and reduced sandy wares (R10/R30) and a reduced sandy ware containing common charred organic inclusions/voids (R60/E10?). This latter fabric may have been of slightly earlier date but due to the highly fragmented nature of the sherd a definitive identification was not possible. Pottery dating to the Roman period was recovered from Trenches 174, 181, 195, 218, 219 and 265.

Discussion

- B.1.8 The bulk of the assemblage spans the late Iron Age and Roman periods, the majority of which was derived from deposits in the central and southern areas of the site.
- B.1.9 Overall, the assemblage was in poor condition. The mean sherd weight (weight divided by sherd count) was 4.7g, which was characteristic of a highly fragmented

assemblage. This suggests that the pottery had been subjected to heavy disturbance.

- B.1.10 The origin of the late Iron Age and Roman pottery could not be positively identified; however, it was most likely of local production. The absence of regional and continental imported wares suggests a reliance on these locally produced wares. The heavily micaceous wares were most likely derived from clays obtained from the Thanet formation which include siliclastic sediments and would have been available locally to the site (BGS 2020).
- B.1.11 Due to its small size and the scarcity of diagnostic sherds it is not possible to provide any further meaningful commentary on the assemblage.

Conservation, discard and retention of material

- B.1.12 The pottery reported on here has the potential to inform future research through re-analysis and thus it is recommended that all the pottery is retained. This follows the advice set out in the 'Standard for Pottery Studies in Archaeology' (PCRG, SGRP, MPRG 2016).

B.2 Ceramic building material

By Pete Banks

Introduction

B.2.1 Nine fragments of ceramic building material (CBM) weighing 295g were recovered; they are categorised in Table 2 below.

Ceramic building material

B.2.2 The assemblage of CBM was highly fragmented and comprised pieces of indeterminate form (6 fragments), flat tile (2 fragments) and brick (1 fragment). The CBM of indeterminate form from Trench 163, 219 and 233 was not dateable.

Ctxt	Count	Wt (g)	Date	CBM Form	Fabric Code	Form notes/ description
16304	2	24			Orange red medium sandy	
21905	1	6			Orange red fine silty with calcareous inclusions	
23004	1	134	Post-medieval/ Modern	Flat	Orange red fine micaceous silty with clay pellet inclusions	Peg Tile
23304	5	131	Post-medieval/ Modern	Flat/Brick	Orange red fine silty with calcareous and clay pellet inclusions	Tile x1, Brick x1

Table 2: Catalogue of ceramic building material

B.2.3 Two fragments of flat tile from deposits 23004 and 23304 were of post-medieval or modern form. Both fragments of tile were made in oxidised silty fabrics with micaceous, clay pellet or calcareous inclusions.

B.2.4 Ditch 23304 (Trench 233) produced one fragment of brick made in an oxidised fine silty fabric with clay pellet and calcareous inclusions. Based on its fabric and conditions of firing it is mostly of post-medieval or modern date.

B.2.5 The ceramic building material assemblage was small and indicative of low levels of activity that required this type of material.

Retention and discard

B.2.6 The CBM was undated or post-medieval/modern in date as such it is not necessary to retain this material.

B.3 Fired clay

By Pete Banks

- B.3.1 Four fragments (12g) of fired clay were recovered; the assemblage is listed in Table 3 below.
- B.3.2 The fired clay assemblage was small and entirely undiagnostic. All four fragments were derived from natural feature 27403 (Trench 274). The fragments were made in a soft oxidised silty fabric with inclusions of flint. Due to the absence of diagnostic features, it was not possible to date the fired clay assemblage or determine its function.

Ctxt	Count	Wt (g)	Date	Fabric	Form	Form notes
27404	4	12	Undated	Orange fine silty fabric with flint inclusions	Indet.	Flat surfaces x 3

Table 3: Catalogue of fired clay

Retention and discard

- B.3.3 Retention of the fired clay assemblage is unnecessary.

B.4 Flint

By Jacky Sommerville

Introduction

- B.4.1 A small assemblage of five struck flints was recovered from this evaluation (Table 4). Single items were recovered from Trenches 136, 181 and 269, and two from Trench 235. Trenches 136 and 181 each produced a microlith of Mesolithic date.

Methodology

- B.4.2 The artefacts were catalogued according to Butler's system of broad artefact/debitage type (Butler 2005), general condition was noted and dating was attempted where possible. Microliths were classified according to Clarke's (1933) system. The assemblage was catalogued directly onto a MS Office spreadsheet.

Category Type	Number
Flake	2
Microlith	2
Retouched flake	1
Total	5

Table 4: Breakdown of flint assemblage by type

Raw material and condition

- B.4.3 The raw material is flint in all cases. Cortex is present on four items – it is chalky on three and abraded on one.
- B.4.4 The flints are mostly in a good condition, with the exception of the retouched flake from ploughsoil deposit 26900, which is heavily edge damaged (as would be expected). The microlith from natural periglacial crack 13606 is missing its tip but displays no other edge damage and the example from ditch 18107 is slightly edge damaged. Of the two flakes from ditch 23505 one is in an undamaged condition and the other displays moderate edge damage – both are distal fragments. All of the flints are uncorticated and one of the flakes from ditch 23505 is iron-stained orange.

Discussion

- B.4.5 The two microliths (from the natural infill 13609 of periglacial crack 13606 and fill 18108 of ditch 18107) are both obliquely blunted points, conforming to Clark's Type 1Ac, which is blunted on the right edge to form an angle (Clark 1933, 56). This type of microlith was used throughout the Mesolithic period (Jacobi 1978, 20).
- B.4.6 The two flakes from fill 23506 of ditch 23505 and the retouched flake from ploughsoil deposit 26900 are not chronologically diagnostic, and only broad prehistoric dating is possible for these. The latter features an area of steep, quite regular retouch on the distal end of the right dorsal edge.
- B.4.7 The small flint assemblage provides evidence of low-level activity during the prehistoric period, including the Mesolithic, although all may be redeposited.

B.5 Metalwork

By Pete Banks

- B.5.1 Two fragments (206g) of iron were recorded from Trenches 129 and 254. The iron objects were in a fragmentary and corroded condition. The metal finds are summarised by context in Table 5.
- B.5.2 A fragment of iron buckle was recovered from ditch 12906. A large iron spike or tent peg was recorded from ditch 25403. The spike was square sectioned and tapered to a point. A small flange at one end was perforated, presumably for securing a cable or line. Both objects are probably of post-medieval or modern date.

Ctxt	Type	Material	Count	Wt (g)	Description	Date
12907	Ditch	Iron	1	22	Fragment of belt buckle	Post-medieval/ Modern
25404	Ditch	Iron	1	184	Large square shafted iron spike or tent peg	Post-medieval/ Modern

Table 5: Summary of metal finds by context

Retention and discard

- B.5.3 It is not necessary to retain any of the metalwork assemblage.

B.6 Glass

By Pete Banks

- B.6.1 One fragment of glass (10g) was recorded from Trench 235. Glass finds are summarised by context in Table 6.
- B.6.2 Ditch 23505 produced a fragment of colourless glass etched with a diamond lattice pattern. The function of the glass could not be determined with certainty due to its poor condition, however, it is possible it represents a fragment of lamp glass from a motor vehicle. The fragment of glass is most likely modern in date.

Ctxt	Material	Count	Wt (g)	Description	Date
23506	Colourless glass	1	22	Curved colourless glass with etched diamond lattice	Post-medieval/ Modern

Table 6: Summary of glass by context

Retention and discard

- B.6.3 Retention of the glass assemblage is not necessary.

C.1 Environmental Samples

By Emma Aitken

Introduction

- C.1.1 Six samples were taken from the evaluation of Land Parcels 48B and 48C (the site) at Mar Dyke Valley A13, Orsett, South at Lower Thames Crossing, primarily for the retrieval and assessment of charred plant remains.

Method

- C.1.1 The samples were processed in their entirety at Oxford Archaeology using a modified Siraf-type water flotation machine. The flots were collected in a 250µm mesh and heavy residues in a 500µm mesh and dried. The residue fractions were sorted by eye and with the aid of a magnet while the flot material was sorted using a low power (x10) binocular microscope to extract cereal grains and chaff, smaller seeds and other quantifiable remains.

Results

- C.1.2 Sample and CPR flot data is summarised in Table 7.
- C.1.3 **Trench 133.** Sample 6 from fill 13308 of pit 13307 contained frequent charcoal fragments (5-25 fragments) that were greater than 2mm in size. A single tentative free-threshing wheat grain (*Triticum turgidum/aestivum* type) was also noted in the assemblage.
- C.1.4 **Trench 175.** An abundant quantity of charcoal fragments larger than 2mm was recovered from fill 17504 (sample 5) of tree-throw 17503. Charred cereal grain fragments were also observed in a small quantity but are too abraded to be fully identified.
- C.1.5 **Trench 199.** Fill 19905 (sample 4) of probable tree-throw 19903 contained a moderately large quantity of charcoal fragments that fall into the >2mm size category.
- C.1.6 **Trench 204.** Sample 2 from fill 20406 of probable tree-throw 20405 contained a small number of charcoal fragments that are larger than 2mm in size.
- C.1.7 **Trench 217.** Sample 3 from fill 21704 of late Iron Age - Roman ditch 21703 contained no charred plant remains.
- C.1.8 **Trench 250.** Fill 25006 (sample 1) of late Iron Age - Roman ditch 25005 contained a small number of charcoal fragments larger than 2mm and a single charred hulled wheat grain (emmer or spelt (*Triticum dicoccum/spelta*)).

Discussion

- C.1.9 The only mode of preservation evident in the sampled contexts and features is charring, with the quantity and quality of the charred remains being relatively low. Sample 5 from tree-throw 17503 produced the greatest quantity of charcoal, and further identification of the charcoal would be possible, if considered informative within the wider context of the site. Sample 4 from pit 19903 also contained a

moderate quantity of charcoal, which could also be identified in more detail should it be considered worthwhile.

C.1.10 The features that show the best potential are the pit and tree-throws. The ditch fills show the least potential. This is not unexpected where ditches, as these are, are located away from areas of occupation.

Sample no.	Context no.	Trench	Feature/ Deposit	Date	Sample vol. (L)	Flot vol. (ml)	Charcoal >2mm	Grain	Chaff	Weeds	Notes
1	25006	250	Ditch 25005	LIA-R	14	3	+	+	-	-	-
2	20406	204	Probable tree-throw 20405		16	12	++	-	-	-	-
3	21704	217	Ditch 21703	LIA-R	32	8	-	-	-	-	-
4	19905	199	Probable tree-throw 19903		27	12	+++	-	-	-	-
5	17504	175	Tree-throw 17503		34	35	++++	+	-	-	-
6	13308	133	Pit 13307		8	25	++	+	-	-	-

Table 7: Assessment of CPR flots

Key: +=present (up to 5 items), ++=frequent (5-25), +++=common (25-100), ++++=abundant (100+). (LIA-R = Late Iron Age - Roman)

Discussion

C.1.11 The flots warrant retention until all works on the wider site are complete but further analysis of the flots described here is not merited at this time.

C.1.12 The charcoal from sample 5 could potentially be considered for further identification as part of a larger material assemblage in the event of further excavation and assessment at this site. This would only be warranted if the feature proved to be of interest archaeologically and the charcoal worthwhile dating.

C.2 Animal Bone

By Andy Clarke

- C.2.1 Animal bone comprising three fragments (295g) was recovered via hand excavation from deposits 13208 and 23004, fills of ditches 13207 and 23003, and primary deposit 19404 of an ill-defined feature (19403). There was no direct association with dateable, artefactual material and so these deposits remain undated. The assemblage was identified using the Cotswold Archaeology reference collection. The condition of the material was assessed according to the weathering stage where 0 indicates excellent preservation and 5 very poor preservation (Behrensmeyer, 1978). Where damage was present and re-fitting was possible, fragments were counted as a single bone.

Ctxt	Cut	Count	Feature Type	Condition	Species	Element	Side	Phase
13208	13207	1	Ditch	3	Cattle	Tibia	Right	Undated
19404	19403	1		4	Cattle	Radius	Right	Undated
23004	23003	1	Ditch fill	3	Medium mammal	Indeterminate		Undated

Table 8: Summary of animal bones by context

C.3 Shell and Molluscs

By Emma Aitken

- C.3.1 A single fragment of oyster shell (*Ostrea edulis*), part of a right-hand valve, was recovered from context 27404, Trench 274.
- C.3.2 Molluscs were noted in three samples (see Table 9) recovered from the site and comprise species such as the open country species *Vallonia* sp., and the intermediate species *Trochulus hispidus*. These species are common in open grassland and arable environments.

Trench	Context	Sample	Feature/Deposit	Molluscs
204	20406	2	Tree-throw	+ (<i>Vallonia</i>)
199	19905	4	Pit 19903	+ (<i>Vallonia</i>)
175	17504	5	Tree-throw 17503	+ (<i>Vallonia</i> , <i>Trochulus</i>)

Table 9: Assessment of molluscs from samples

Appendix D Geoarchaeological Report

By Elizabeth Stafford

Introduction

- D.4.1 The geoarchaeological component of the evaluation on land within the Mar Dyke Valley (Land Parcels 48B and 48C) comprised the observation and targeted recording of the sedimentary sequences exposed in the trenches to supplement standard archaeological recording.
- D.4.2 As outlined in the WSI, one of the principal objectives of the evaluation was to investigate the archaeological potential of the Holocene sequences, to identify whether features and/or artefact scatters are preserved within or beneath alluvium and/or colluvium and if any *in situ* buried soils/land surfaces can be detected. The evaluation also intended to provide preliminary information on the nature, depth, and distribution of any deposits identified as cold climate Head, brickearth or fluvial gravel, in advance of a second phase of purposive test-pitting intended to evaluate the underlying Pleistocene/Palaeolithic potential of the sedimentary sequences.
- D.4.3 The area under investigation has been previously reviewed as part of the scheme-wide Palaeolithic and Quaternary Deposit Model (PQDM) (Wenban-Smith and Bates 2020). It falls within Zone PQ-20a (Green Lane), characterised geologically by London clay (over Lambeth Group) bedrock, blanketed by a swath of 'Head' deposits. The BGS does not map any spreads of Terrace Gravels across this area of site. The preliminary Palaeolithic potential was assessed as being low to moderate.
- D.4.4 Ground levels average c 13m aOD in the south, dropping to c 5m aOD in the northern half of LP48B and 48C as the scheme approaches the lower-lying floodplain area, the boundary of which is marked by a modern open drainage channel. Beyond the drain to the north lies a complex palaeochannel zone identified from LiDAR data marking the original course of the Mar Dyke channel prior to realignment. Here ground levels drop rapidly to c 3m aOD. Assessment of previous geotechnical borehole data suggested the Holocene sequences to be relatively shallow (c 0.5-1.0m) across LP48B and 48C, although interpretation of alluvial and Head deposits appeared ambiguous.

Method

- D.4.5 The trenches were excavated to a maximum of 1m below ground level (BGL), or less than that where clear Pleistocene Head or bedrock was exposed, or where archaeological features were detected. Trenches across the site were initially inspected by a geoarchaeologist. A small selection were recorded in detail, mostly in the northern part of LP48B where a possible alluvial subsoil was observed.
- D.4.6 The recording of the sediments comprised the detailed geoarchaeological logging of one or more 1-2m wide sections, the number depending on the complexity of the sequences. Each section was allocated a section number and located relative to the National Grid and Ordnance Datum. The sediment sequences were recorded from ground surface on a geoarchaeological log proforma with each layer allocated a unique context number. Preliminary interpretations of associated depositional processes were also recorded on the logs. Sediment recording followed Jones *et al.*

1999 and typically included a description of texture, compaction, colour, clast size and abundance, bedding structures and other inclusions (eg. charcoal), post-depositional features (eg. rooting, mottling, mineralisation), and the nature of sediment contacts (eg clear, abrupt, diffuse, irregular).

- D.4.7 Numerous site visits during the evaluation were attended by Francis Wenban-Smith (LTC Palaeolithic specialist) and Elizabeth Stafford (OA Geoarchaeology Manager) to observe the sedimentary sequences exposed in the trenches, discuss formation processes and key objectives and strategies for further excavation and recording.

Results

- D.4.8 Overall, the sequence observed within the trenches were relatively shallow, invariably modern ploughsoils directly overlay deposits interpreted as Pleistocene Head and/or weathered bedrock. Slightly deeper sequences were exposed in the northern part of LP48B, although these largely comprised thin minerogenic alluvial subsoils overlying Pleistocene Head. The sequences were considered of low geoarchaeological potential and no organic deposits or clear buried soils were observed. Consequently, only a small amount of detailed geoarchaeological recording was carried out in three trenches and no samples were recovered.

- D.4.9 **Trench 122** was located on generally flat topography and was excavated to 1.1m deep in a sondage at the northern end of the trench. The ground level (GL) recorded at section 122 (Plate 26) was 4.64m OD and the deposit sequence comprised:

- 0.00-0.33m (12200): Mid to dark greyish brown slightly clayey silt. Abundant (20%) subrounded pebbles (<30mm). Sharp contact. **PLOUGHSOIL**;
- 0.33-0.60m (12201): Firm mid yellowish brown slightly silty clay. Abundant (40%) pebbles, subrounded and subangular. Few (10%) manganese inclusions. **HEAD**;
- 0.60-0.95m (12202): Soft strong brown mottled blueish grey stoneless silty clay. **ERODED/WEATHERED LONDON CLAY**; and,
- 0.95-1.10m (12203): Strong brown mottled bluish grey stoneless silty clay with patches of pale calcareous? sediment. Rare (1%) pebbles. **LONDON CLAY**.

- D.4.10 **Trench 136** was excavated on generally flat topography to a maximum of 1.07m BGL in a sondage at the northern end of the trench (Plate 27). The remainder of the trench was excavated to a much shallower depth at c 0.5m BGL due to the location of periglacial crack [13606], originally interpreted as a ditch, and possible pit [13603]. A Mesolithic microlith was recovered from fill 13609 of periglacial crack 13606. The sequence recorded in section 13602 (GL: 5.82m OD), comprised:

- 0.00-0.30m (13600): Firm dark brownish grey clayey silt with rare (1%) subrounded pebbles (<30mm). Sharp irregular contact. **PLOUGHSOIL**;
- 0.30-0.56 (13601) Soft mid yellowish brown slightly sandy silty clay. Rare (<1%) subangular pebbles and manganese flecks. Some evidence of rooting, Diffuse contact. **(ALLUVIAL?) SUBSOIL**;
- 0.56-0.78m (13602): Moderately firm dark yellowish brown slightly sandy silty clay. Occasional (5%) manganese flecks, rare (1%) subangular pebbles. Some evidence of rooting. Clear contact. **HEAD?**;
- 0.78-0.98m (13611): Moderately firm dark yellowish brown mottled, slightly sandy silty clay. Occasional (3%) manganese flecks, generally stoneless apart from a large pocket of compacted very gravelly sandy clay to one side of the section (13613). **HEAD/WEATHERED LONDON CLAY**; and,

- 0.98-1.07m (13612): Dense mid yellowish brown mottled light grey silty clay. Occasional (3%) manganese flecks, stoneless. Polished surfaces. **LONDON CLAY.**

D.4.11 **Trench 146** was excavated on generally flat topography. Two 1m deep, 1m wide sections were recorded at each end (Sections 14600 and 14601). In Section 14601 (Plate 28) the ground level was recorded at c 6.33m OD. The deposit sequence comprised:

- 0.00-0.20m (14600): Firm dark yellowish brown clayey silt. Rare (1%) subrounded pebbles (<30mm). Clear contact. **PLOUGHSOIL;**
- 0.20-0.38m (14601): Firm mid yellowish brown silty clay with few subangular pebbles (3%). Patches of mottled light grey silty clay. Clear contact. **(ALLUVIAL?) SUBSOIL;**
- 0.38-0.55 (14602) Firm greyish brown silty clay with an 80mm bed of moderately to poorly sorted subrounded pebbles (mainly <30mm). Manganese flecks (3%) towards base. **GRAVELLY HEAD;** and,
- 0.55-0.90 (14603) Soft mid yellowish brownish silty clay, with patches of strong brown clayey sand. Frequent (10%) rounded pebbles, compacted within sand towards the base of the section. **GRAVELLY HEAD.**

D.4.12 The London clay bedrock was not recorded in Section 14601 but was observed in the southern end of the trench in Section 14600 at c 0.53m BGL (5.73m aOD, GL: 6.26m aOD), suggesting the underlying bedrock geology dips northwards at this location.

Discussion and potential

D.4.13 Overall, the (Holocene) sediment sequences observed within the excavated trenches across LP48B and 48C appeared relatively unremarkable and generally quite shallow. Ploughsoils invariably overlay oxidised minerogenic Pleistocene Head-type deposits that contained a variable clast component. It is probable these deposits are of polymorphic origin, having formed from a combination of weathering of the London clay bedrock, perhaps deflation under arid cold climate conditions, and erosion/redeposition of material from higher ground to the south. In places gravelly pockets appeared convoluted and mixed suggestive of structural deformation (cryoturbation).

D.4.14 In the very northern part of the site a discontinuous thin silty clay deposit was recorded overlying the Head, sealed by ploughsoils, described as a possible alluvial subsoil. In places this deposit appeared slightly stony and may contain some colluvial element at this location at the edge of the Mar Dyke floodplain. However, the deposit appeared oxidised and of low palaeoenvironmental or dating potential. No significant depth of alluvium or obvious buried soils or organic sediments were recorded in any of the trenches.

Appendix E References

- Atkinson, M and Preston, S J, 2015 'Heybridge: A Late Iron Age and Roman Settlement, Excavations at Elms Farm 1993-5' *Internet Archaeol.* **40** [REDACTED] (accessed 19th October 2021)
- Barclay, A, Booth, P, Knight, D, Evans, J, Brown, D H and Wood, I, 2016 *A Standard for Pottery Studies in Archaeology* Historic England
- Behrensmeyer, A K, 1978 *taphonomic and ecologic information from bone weathering.* *Paleobiology* **4**: 150-162
- BGS 2021 *Geology of Britain Viewer.* Retrieved from [REDACTED]
- Biddulph, E, Compton, J and Martin, T S, 2015 'The Late Iron Age and Roman Pottery' in Atkinson M and Preston S J(eds)
- Booth, P, 2019 Oxford Archaeology Roman pottery recording system: an introduction, unpublished
- Butler, C, 2005 *Prehistoric Flintwork*, Stroud, Tempus
- Chartered Institute for Archaeologists (CIfA), 2014a (Revised Oct 2021) *Code of conduct: professional ethics in archaeology*
- Chartered Institute for Archaeologists (CIfA), 2014b (Revised Oct 2020) *Standard and Guidance for Archaeological Field Evaluation.* Retrieved from [REDACTED]
- Chartered Institute for Archaeologists (CIFA), 2014c (Revised Oct 2020) *Standard and Guidance for the Creation, Compilation, Transfer and Deposition of Archaeological Archives.*
- Clark, J G D, 1933 'The classification of a Microlithic Culture: The Tardenoisian of Horsham', *Archaeol. J.* **90**, 52–77
- Drewett, P (ed.) 1978 *Archaeology in Sussex to AD 1500.* CBA Research Report **29**. Council for British Archaeology. London
- Going, C J, 1987 *The Mansio and other sites in the south-eastern sector of Caesaromagus: the Roman pottery* Counc. Brit Archaeol. Res. Rep **62**
- Highways England, 2018 *Lower Thames Crossing: A Scheme Wide Specification for Archaeological Trial Trenching: unpublished document HE540039-CJV-GEN-GEN-SPE-HER-00001draft, Revision 1.05.*
- Historic England 2015 *Management of Research Projects in the Historic Environment: The MoRPHE Project Managers' Guide.* Swindon: Centre for Archaeology Guidelines
- Jacobi, R, 1978 'The Mesolithic of Sussex'. In Drewett, P. (ed.) 1978, 15–22

- Jones, A P, Tucker, M E, and Hart, J K, 1999 Guidelines and Recommendations, in The description and analysis of Quaternary stratigraphic field sections, Technical Guide No. 7. (eds A P Jones, M E Tucker and J K Hart), Quaternary Research Association: London, 27-76
- Magnitude Surveys, 2020 *Geophysical Survey Report of Lower Thames Crossing Essex*
- Medlycott, M ed., 2011 *Research and Archaeology Revisited: A Revised Framework for the East of England*, East Anglian Archaeology Occasional Paper **24**: Association of Local Government Archaeological Officers
- Oxford Archaeology, 2021 *Lower Thames Crossing: Detailed Written Scheme of Investigation P for Trial Trenching of Land Parcels 43, 45-48, 120-125*. Oxford Archaeology
- Oxford Cotswold Archaeology, 2020a *Lower Thames Crossing: Archaeological Evaluation report for Trial Trenching of Land Parcel 22, Whitfield South Scheduled Monument Complex, South of Stifford Clays Road, Baker Street, Essex*, unpublished document HE540039-CJV-GEN-GEN-REP-GEO-00026
- Oxford Cotswold Archaeology 2020b *Lower Thames Crossing: Archaeological Evaluation report for Trial Trenching of Land Parcel 21, Whitfield, North of Stifford Clays Road, Baker Street, Essex*, unpublished document HE540039-BAL-GENGEN-REP-HER-00027
- Oxford Archaeology, 2019a *Lower Thames Crossing Scheme-wide Written Scheme of Investigation for Trial Trenching south of the River Thames*
- Oxford Archaeology 2019b *Lower Thames Crossing Scheme-wide Written Scheme of Investigation for Trial Trenching north of the River Thames*
- Place Services, 2019 *Lower Thames Crossing Aerial Investigation and Mapping Report, Essex County Council*
- PCRG, 2010 *Prehistoric Ceramics Research Group guidelines*, Occasional Papers **1** and **2**

Appendix F Abbreviations and Glossary

ADS Archaeology Data Service. Digital archaeological archive

CDM Construction Design Manual. Health and safety guidance for the construction industry

CPD Continuing Professional Development

CIfA Chartered Institute for Archaeologists

DBA Desk Based Assessment. Detailed assessment of archaeology and other aspects of the historic environment

DCO Development Consent Order

EIA Environmental Impact Assessment. Detailed study of environmental impacts as directed under The Town and Country Planning (Environmental Impact Assessment)

Regulations 2017 following on from EU Directive EIA Directive (85/337/EEC)

ES Environmental Statement. The principal environmental report detailing environmental impacts within an EIA

GPS Global Positioning System

HER Historic Environment Record

LTC Lower Thames Crossing

MCIfA Member of the Chartered Institute for Archaeologists

MoRPHE Management of Research Projects in the Historic Environment

NMP National Mapping Programme. A study of aerial photographs and digitisation of resulting data into GIS. Originally funded by Historic England

OASIS Online Access to the Index of archaeological investigations.

The OASIS project brings together a number of strategic partners: the Archaeology Data Service, Historic England, Historic Environment Scotland, and the Royal Commission on the Ancient and Historical Monuments of Wales under the umbrella of the University of York

OCN Old County Number. Historic England's reference for material that is not readily-available online and may represent historic archaeological work that consists of paper archives or has yet to be formally reported on

PINS Planning Inspectorate

RAMS Risk Assessment Method Statement

SMC Scheduled monument consent

TDR Trusted Digital Repository

UKIC United Kingdom Institute for Conservation

WSI Written Project of Investigation. A detailed method statement for archaeological work

WSL – Western Southern Link

The Western Southern Link (WSL) is an alternative for Short List Routes 2, 3 and 4 to the south of the River Thames.

Appendix G Site Summary

Site name:	Lower Thames Crossing Land Parcels 48B and 48C Mar Dyke Valley, between South Ockendon and Orsett
Site code:	LTC43M21
Grid Reference	NGR 561994 183659
Type:	Evaluation
Date and duration:	Twelve weeks, from 5th July - 24th September 2021
Area of Site	29.71ha

Location of archive:

The archive from Land Parcels 48B and 48C will form part of the overall trial trenching scheme archive. This will be deposited in a repository consistent with the standards required by the Museums and Galleries Commission following completion of the archaeological phase of this project. This may either be with the local receiving museum in Thurrock or, if no such repositories are available, with a repository for the whole project designated by LTC. LTC retain the overall responsibility for the successful deposition of the project archive.

Currently, the archive is held at Oxford Archaeology's head office, Janus House, Osney Mead, Oxford, Oxfordshire, OX2 0ES. Oxford Archaeology will store the archive for LTC for a maximum period of 2 years following the completion of the project. If arrangements for the deposition of the archive have not been completed by this time, an extension to the storage period and final deposition timetable will be reviewed by OA and LTC and agreed with the Key Archaeological Stakeholders.

Summary of Results:

Oxford Cotswold Archaeology was commissioned by Balfour Beatty to undertake a trial trench evaluation of Land Parcels 48B and 48C of the Lower Thames Crossing Pre-Enabling Works. Land Parcels 48B and 48C are located c 800m NW of the village of Baker Street in the historic parish of South Ockendon in Thurrock unitary authority within the county of Essex (NGR 561994 183659). The evaluation comprised 157 trenches and was completed between the 5th July and the 24th September 2021.

A total of 58 trenches revealed features of archaeological significance. These features were distributed across the site on the head clay deposits located on the southern slope of the Mar Dyke river valley with no particularly evident foci of activity.

The earliest activity was limited to two worked flints of Mesolithic origin. The occurrence of these artefacts in such small numbers suggests that activity during this period was little more than transitory.

The results suggest the site lay within the agricultural hinterland of the Iron Age and Roman settlement evaluated within Land Parcels 21 and 22, located on the high ground overlooking the southern slope of the Mar Dyke valley. Remains within the site principally comprised narrow, shallow cultivation or agricultural drainage ditches. A number of these were broadly aligned NE-SW and NNE-SSW and others more or less perpendicular to these on NW-SE and WNW-ESE alignments. The majority of these features remain undated but are considered likely to be associated with the few examples from which late Iron Age - early Roman and Roman pottery was recovered. A series of other ditches in Land Parcel 48C share similar characteristics but are aligned more north to south. A

single abraded sherd of Roman pottery was recovered from one ditch.

The evidence recorded in Land Parcels 48B and 48C should be considered in conjunction with the results from the evaluation of Land Parcels 21 and 22. This suggests that the present investigation probably represents the outer element of the core settlement's agricultural hinterland.

Post-medieval field boundaries were encountered in both land parcels, which were also evident in the cropmark data and on 19th century historic mapping.

\\10.0.10.86\Projects\1010\Geomatics\03 GIS Projects - LTC43M21\Figures\LTC43M21_48B-48C_Report_Fig1.mxd\caroline.souday\09/11/2021

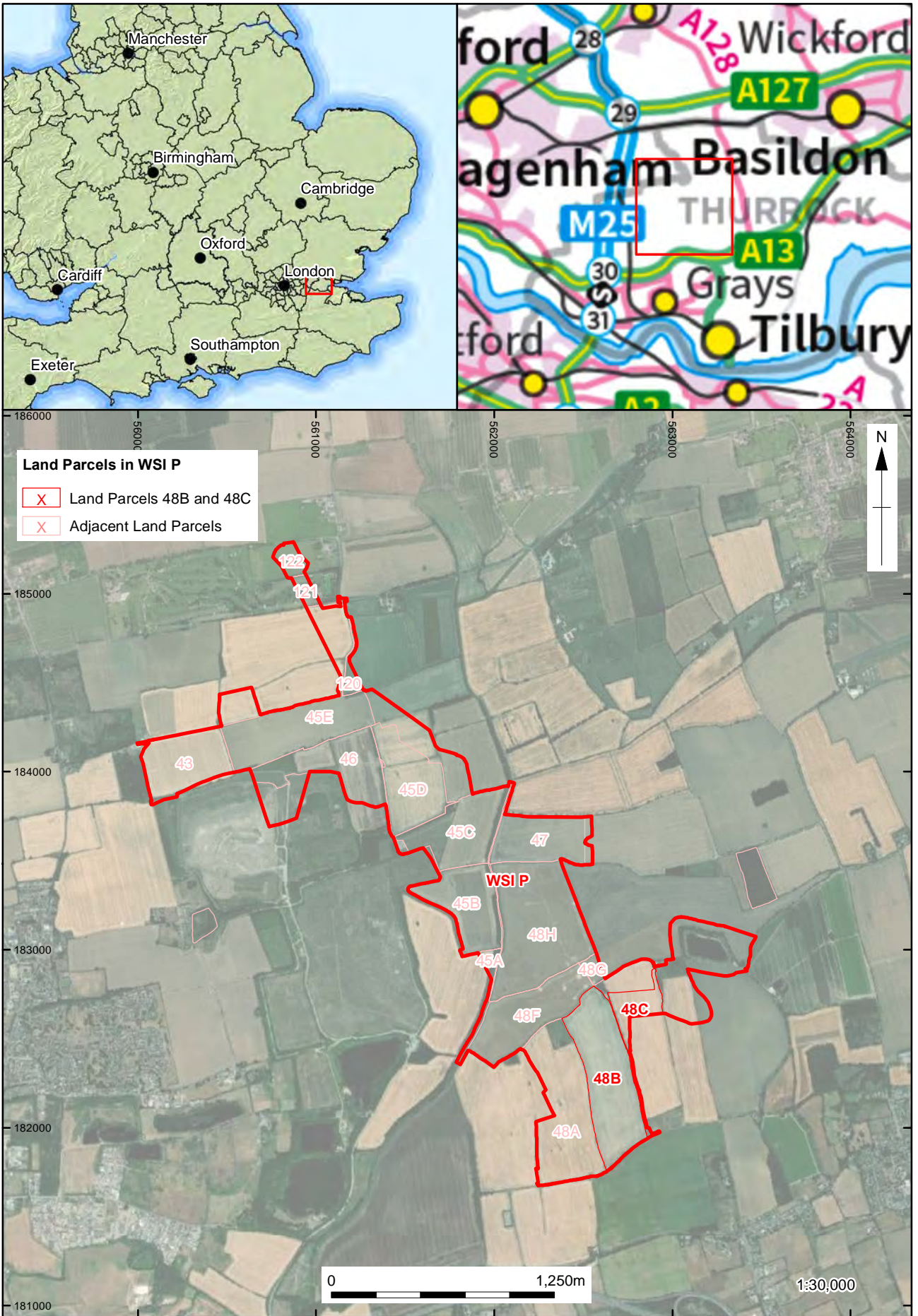

Source: Esri, Maxar, GeoEye, Earthstar Geographics, CNES/Airbus DS, USDA, USGS, AeroGRID, IGN, and the GIS User Community
Contains Ordnance Survey data © Crown copyright and database right 2016

Figure 1: Map showing the location of Land Parcels 48B and 48C

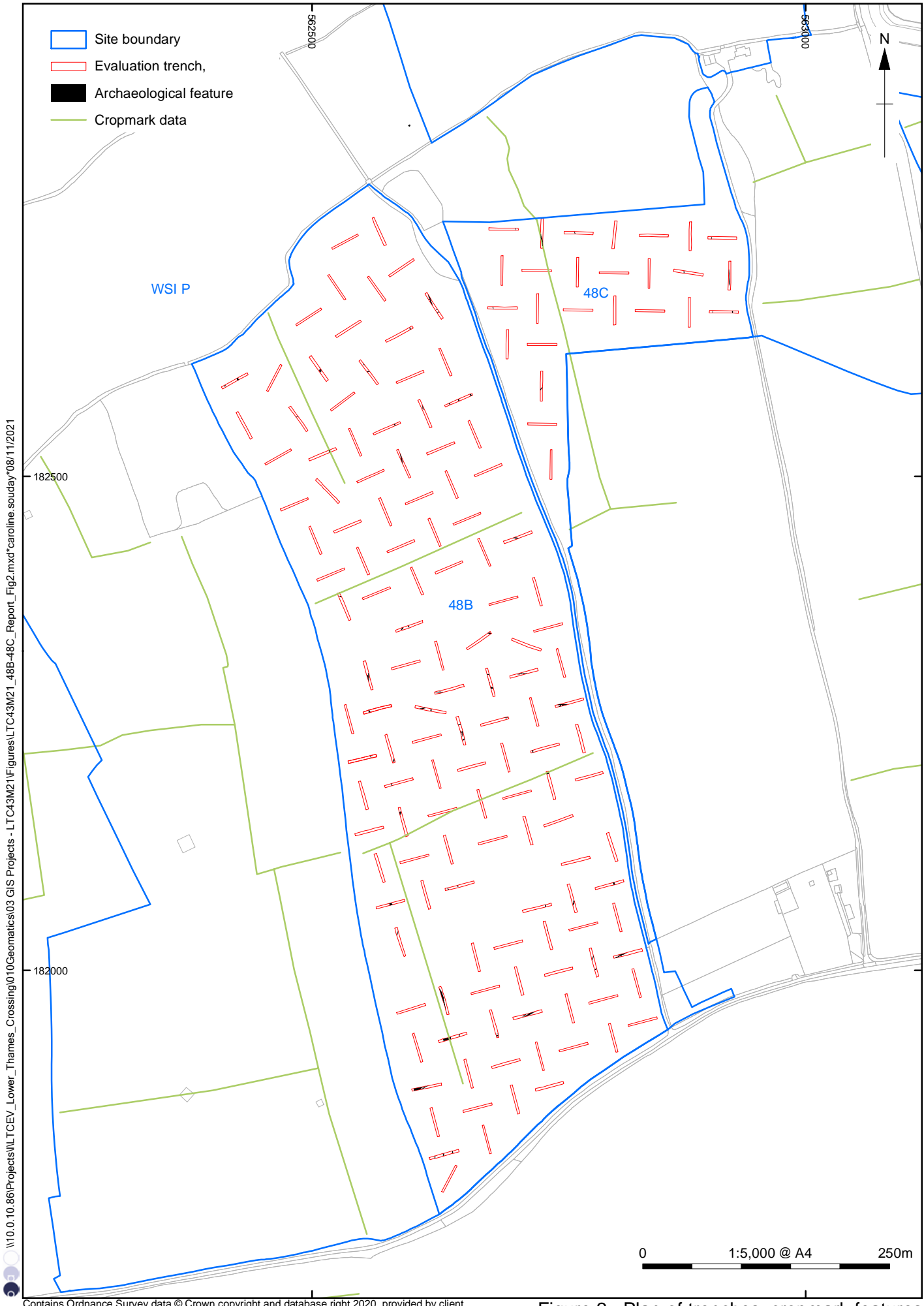

Figure 2 : Plan of trenches, cropmark features and archaeological features

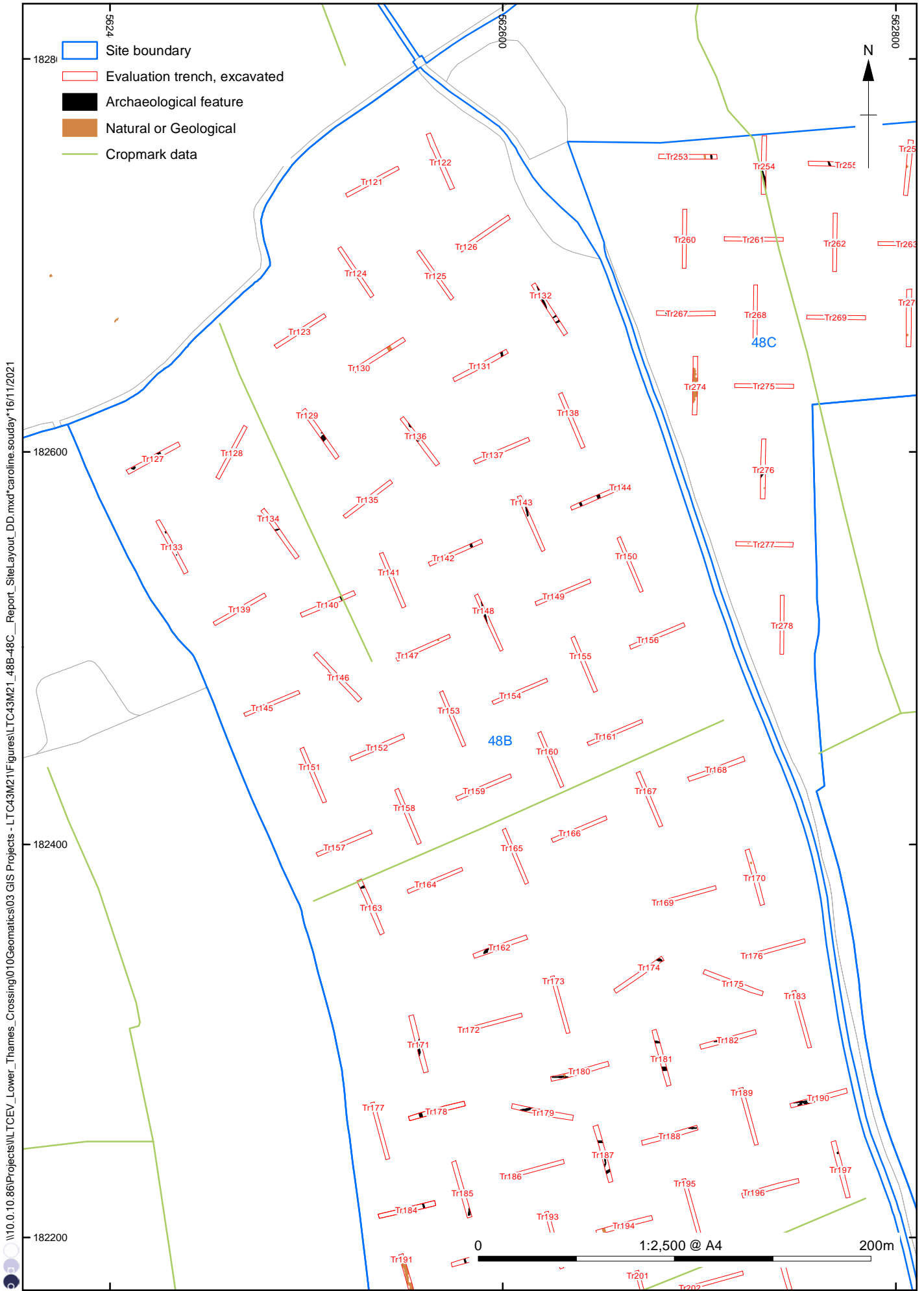
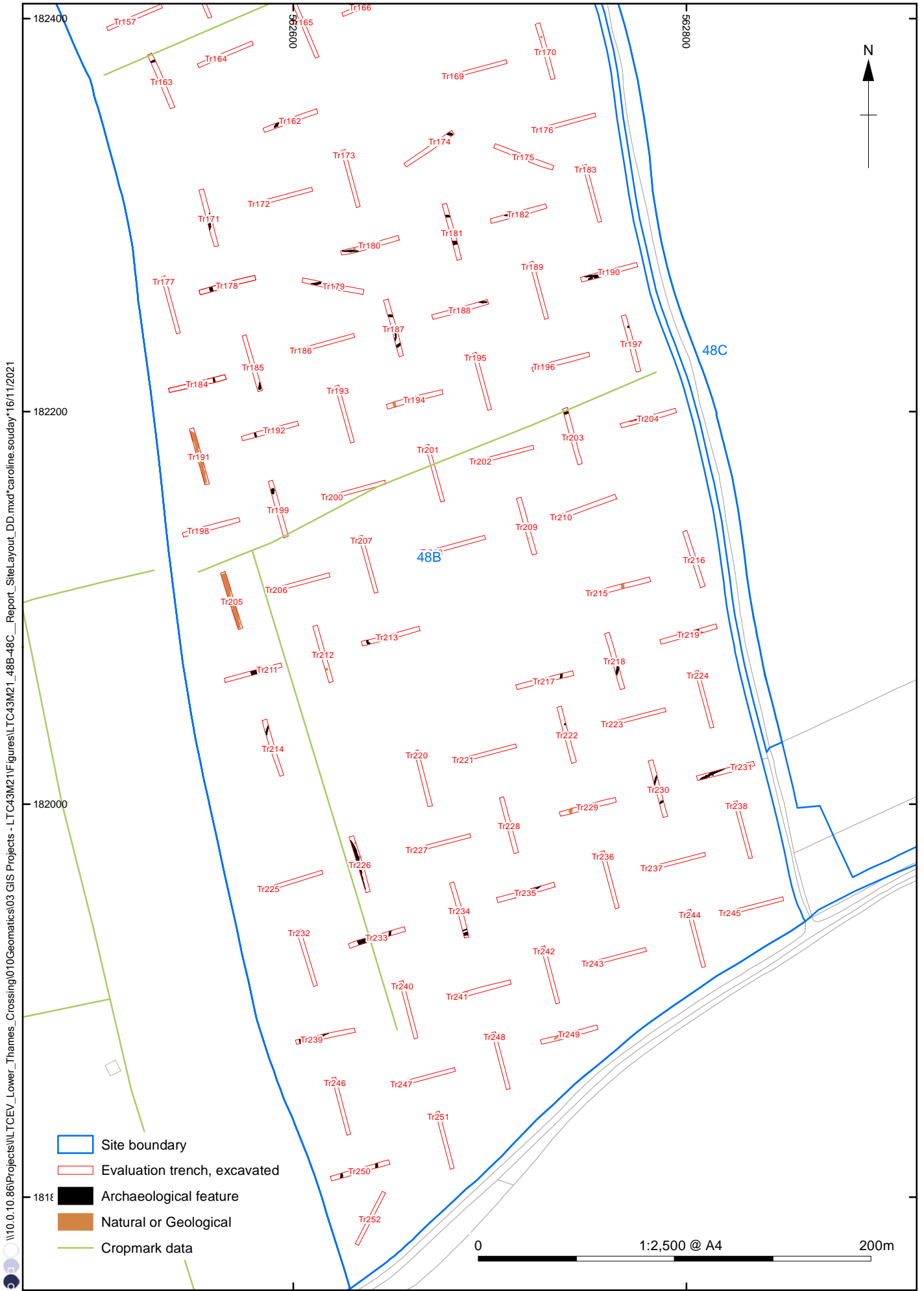

Figure 3: Detailed overview of north half of Land Parcel 48B



\\10.0.10.86\Projects\LT_C43M21\Figures\LTC43M21_48B-48C_Report_SiteLayout_DD.mxd*caroline.souday*16/11/2021

Contains Ordnance Survey data
 © Crown copyright and database right 2020, provided by client

Figure 4: Detailed overview of south half of Land Parcel 48B

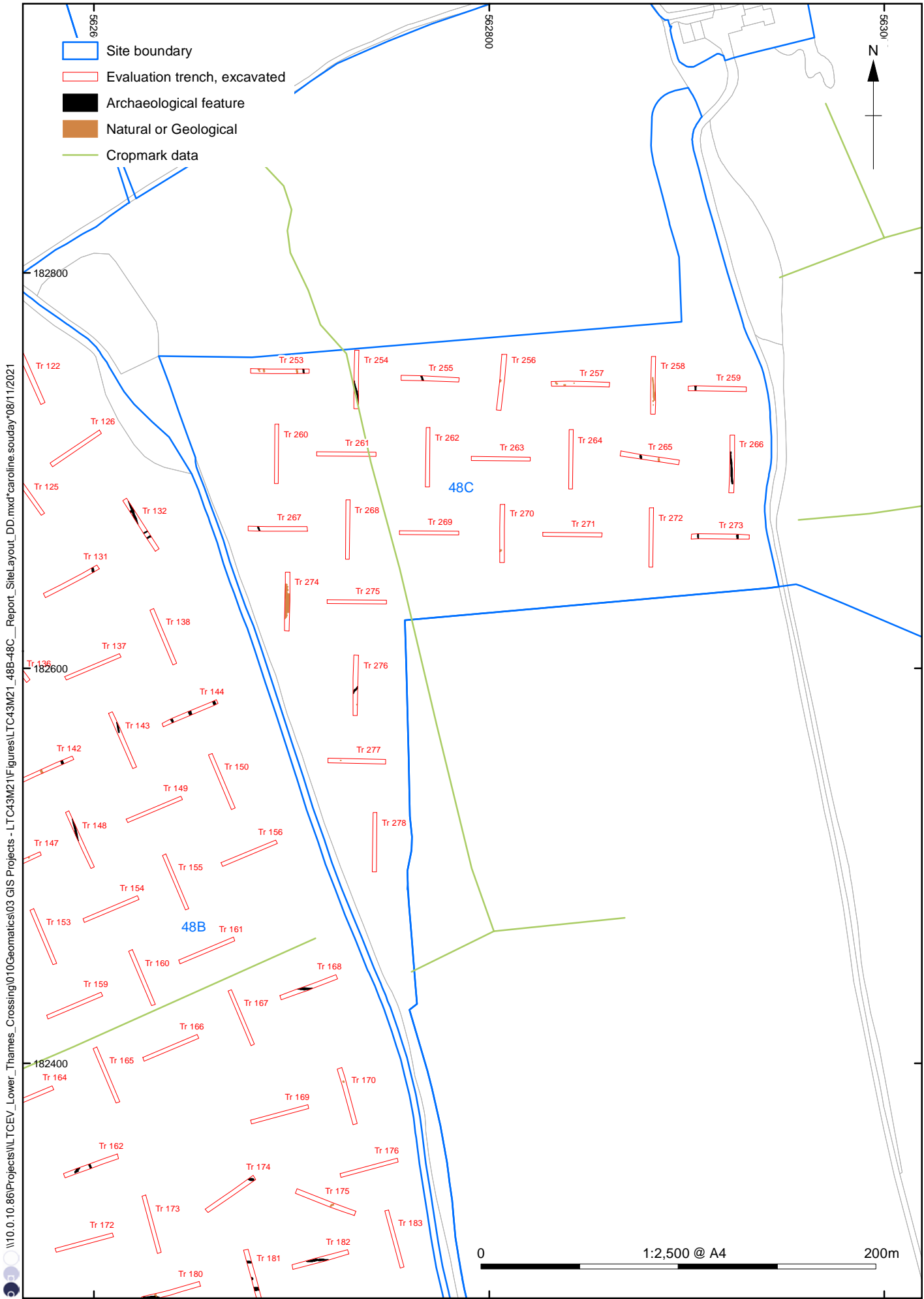

I:\10.0.10.86\Projects\10\Geomatics\03 GIS Projects - LT C43\M2\Figures\LTC43M2_48B-48C_Report_SiteLayout_DD.mxd\caroline.souday\08/11/2021

Contains Ordnance Survey data
 © Crown copyright and database right 2020, provided by client

Figure 5: Detailed overview of Land Parcel 48C

\\10.0.10.86\Projects\Lower_Thames_Crossing\GIS\Projects - L2\7\21\Figures\TC43M21_48B-48C_Report_TrenchPlans_DD_A3.mxd caroline.souday*17/11/2021

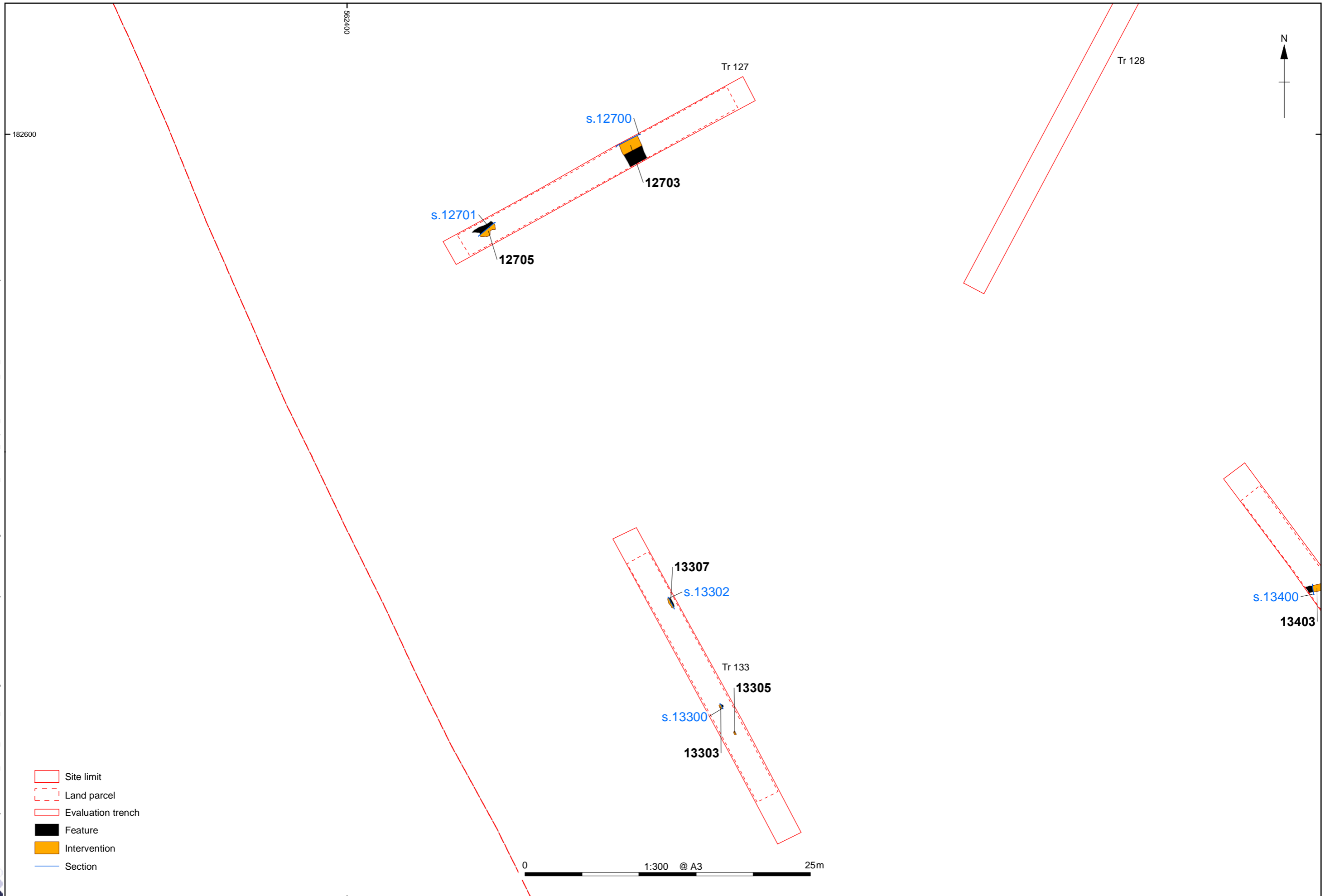
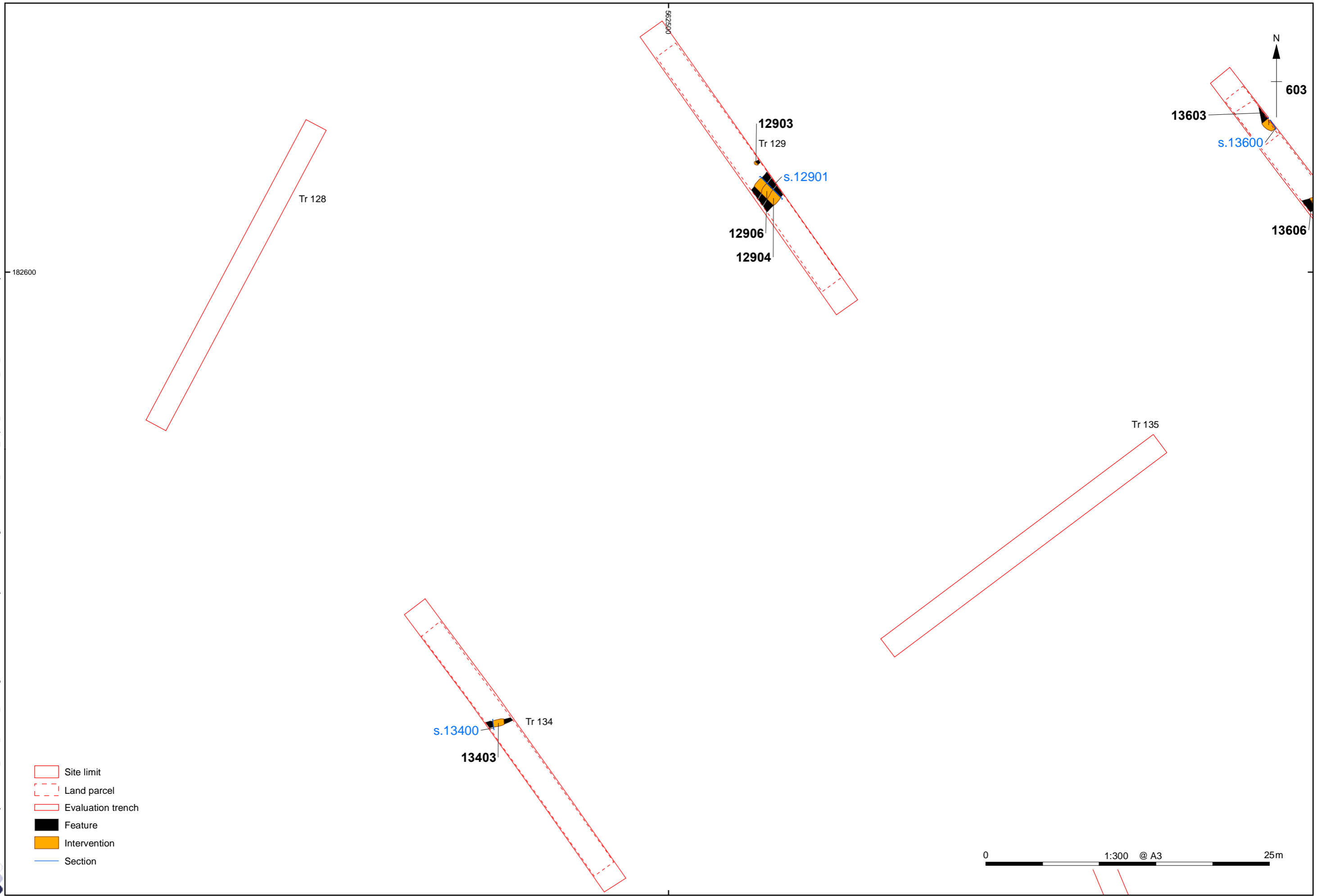

Figure 6: Plan of Trenches 127, 133

\\10.0.10.86\Projects\ILTCEV_Lower_Thames_Crossing\010Geomatics\03 GIS Projects - LT\7L21\Figures\TC43M21_48B-48C_Report_TrenchPlans_DD_A3.mxd caroline.souday*17/11/2021



- Site limit
- Land parcel
- Evaluation trench
- Feature
- Intervention
- Section

0 1:300 @ A3 25m

Figure 7: Plan of Trenches 128-9 and 134-5

\\10.0.10.86\Projects\Lower_Thames_Crossing\010\Geomatics\03 GIS Projects - LT\7L21\Figures\TC43M21_48B-48C_Report_TrenchPlans_DD_A3.mxd caroline.souday*17/11/2021

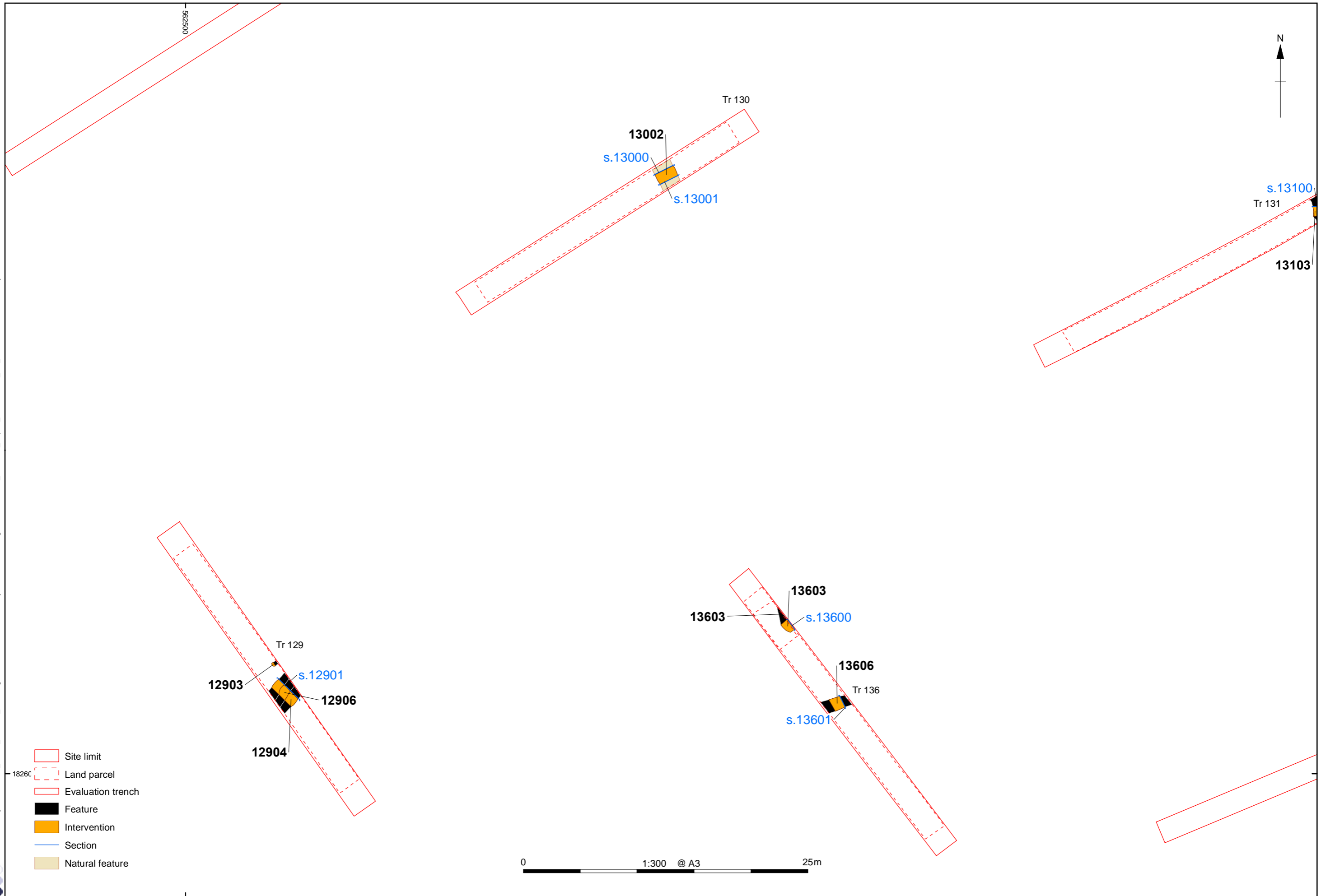

Figure 8: Plan of Trenches 129-30 and 136

\\10.0.10.86\Projects\ILTCEV_Lower_Thames_Crossing\010\Geomatics\03 GIS Projects - LT\7L21\Figures\TC43M21_48B-48C_Report_TrenchPlans_DD_A3L.mxd\caroline.souday*17/11/2021

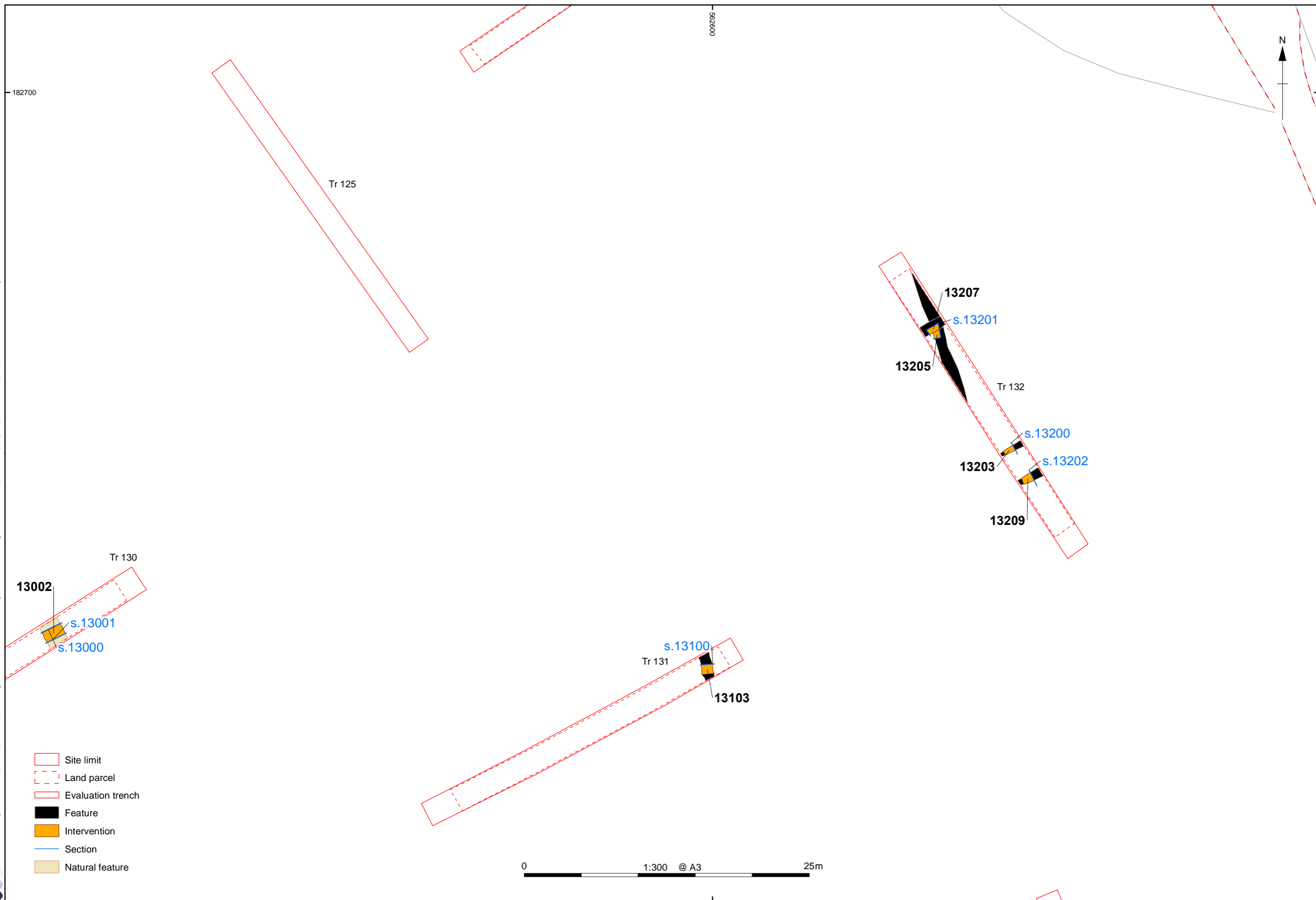

Figure 9: Plan of Trenches 125 and 131-2

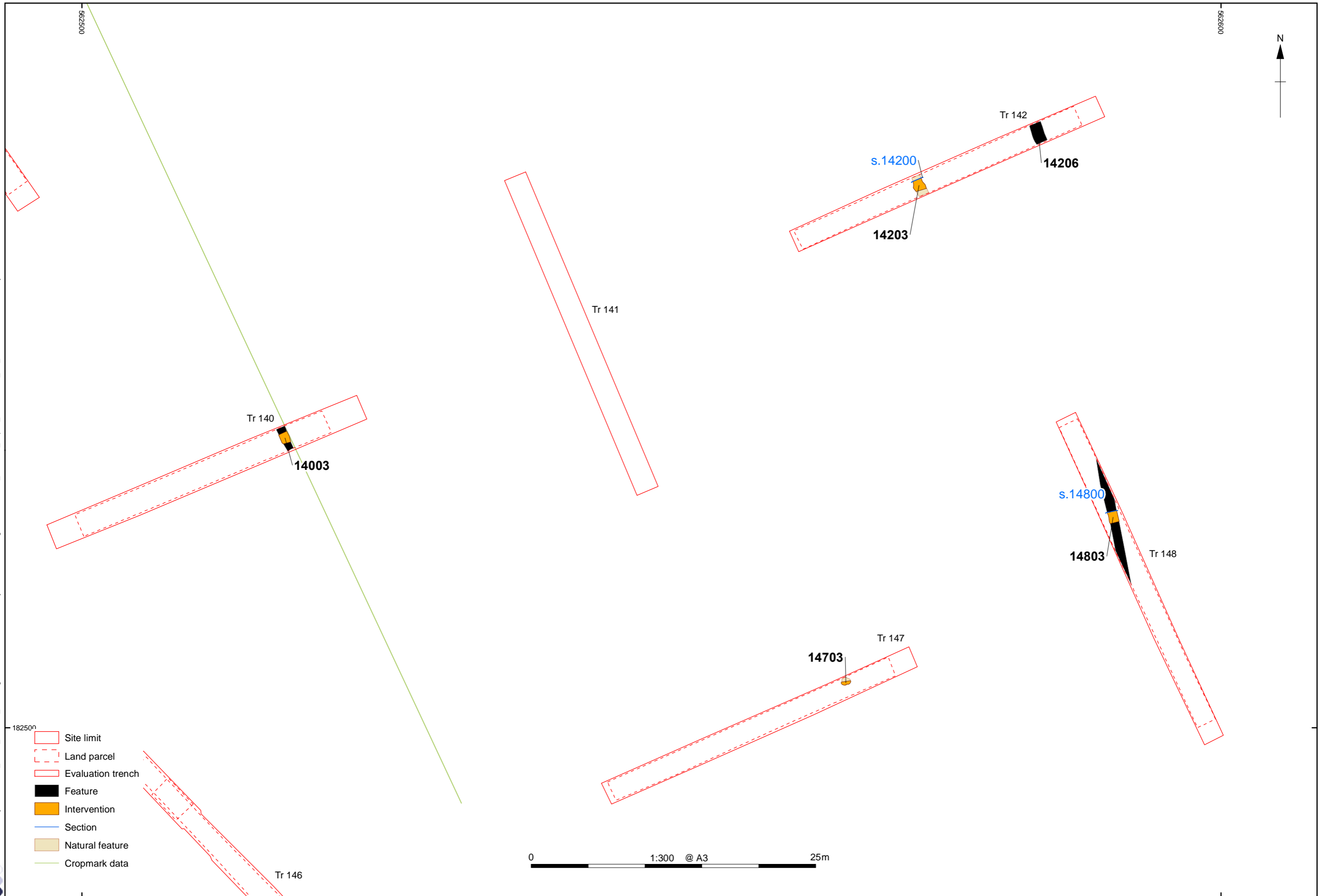

Figure 10: Plan of Trenches 140-2, 147 and 148

\\10.0.10.86\Projects\ILTCEV_Lower_Thames_Crossing\010\Geomatics\03 GIS Projects - LT\7L21\Figures\TC43M21_48B-48C_Report_TrenchPlans_DD_A3L.mxd\caroline.souday*17/11/2021

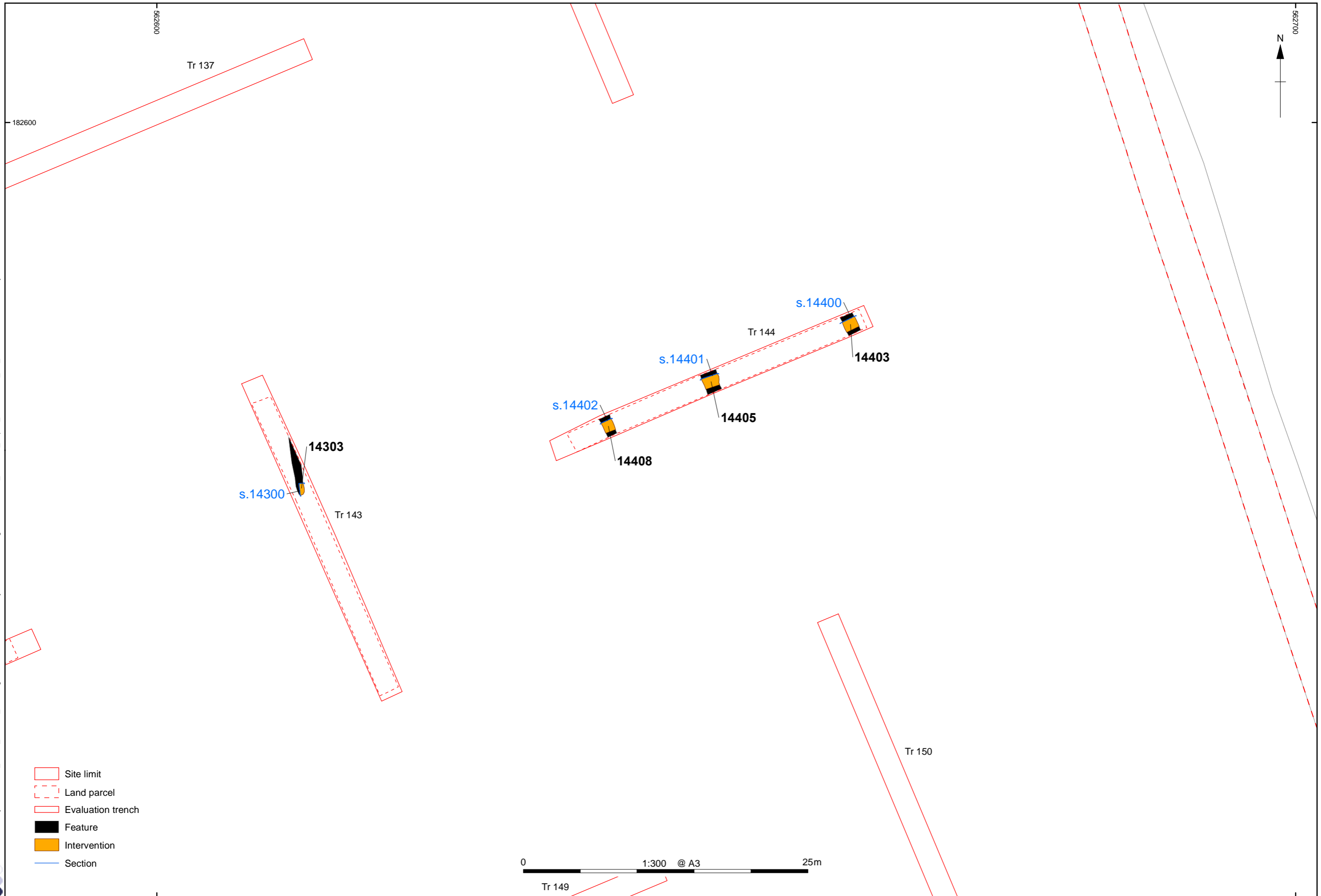

Figure 11: Plan of Trenches 143-4

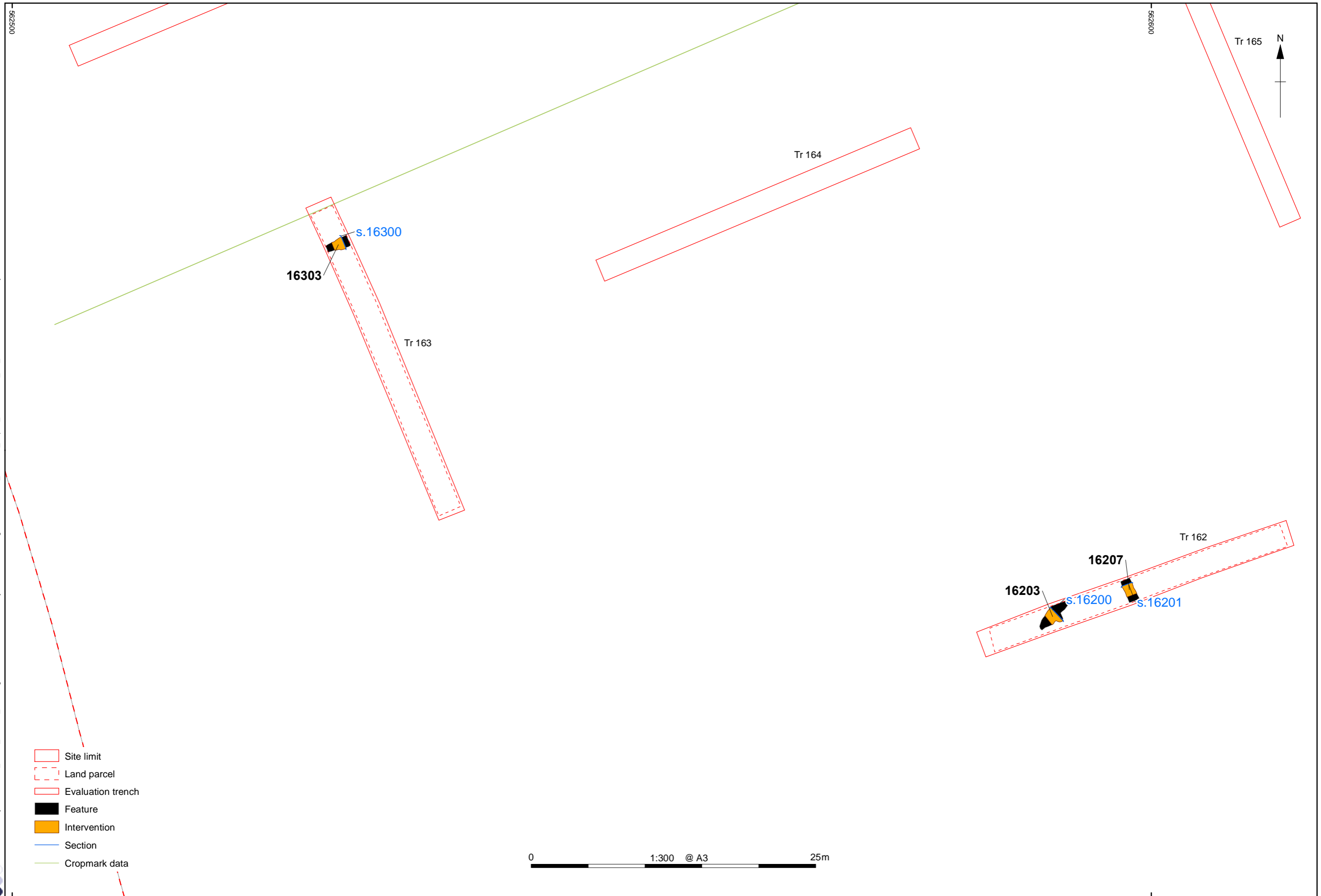

Figure 13: Plan of Trenches 162-164

\\10.0.10.86\Projects\ILTCEV_Lower_Thames_Crossing\010Geomatics\03 GIS Projects - LT07L21\Figures\TC43M21_48B-48C_Report_TrenchPlans_DD_A3.mxd caroline.souday*17/11/2021

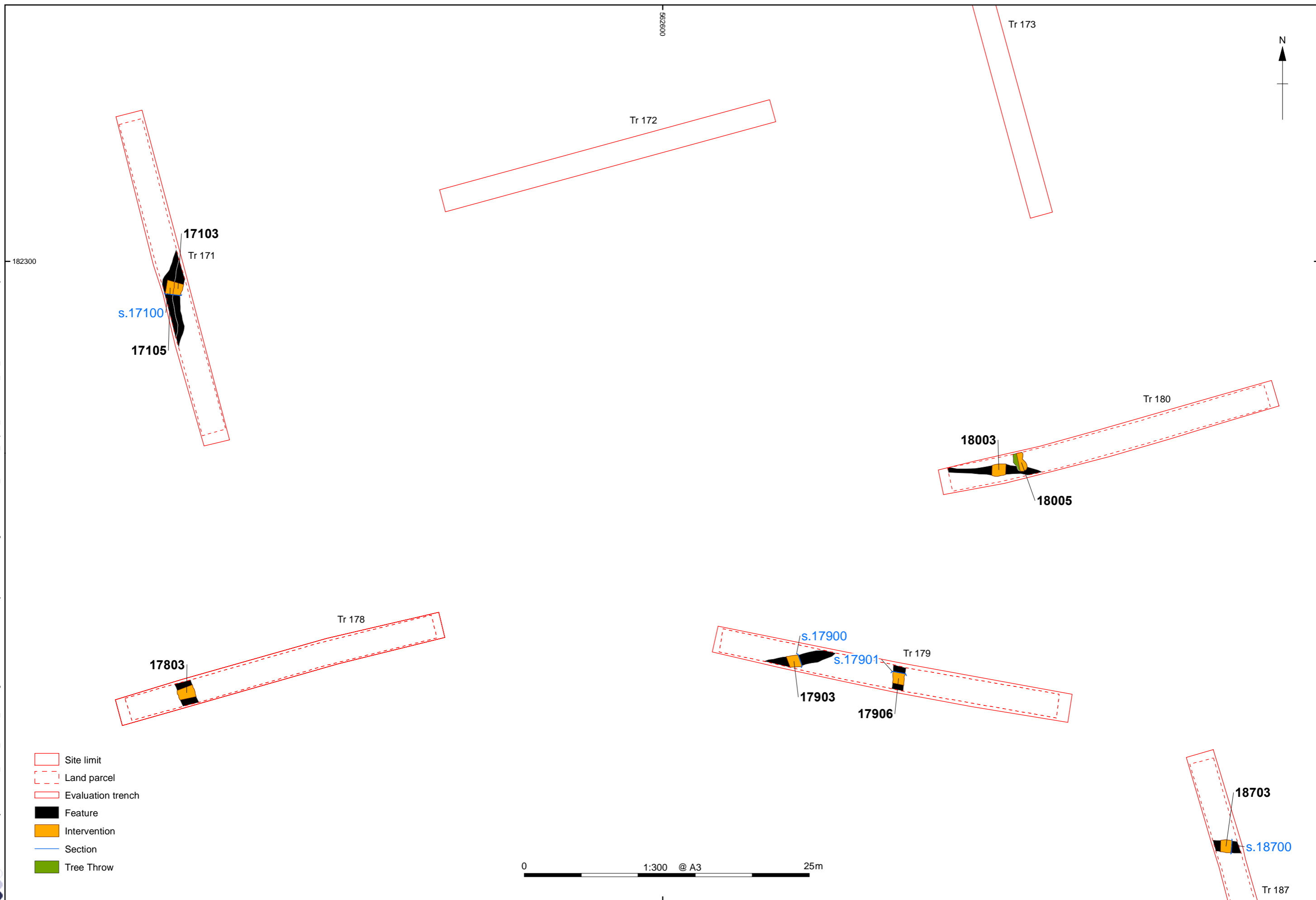

Figure 14: Plan of Trenches 171-2 and 178-180

\\10.0.10.86\Projects\ILTCEV_Lower_Thames_Crossing\010Geomatics\03 GIS Projects - LT\7L21\Figures\TC43M21_48B-48C_Report_TrenchPlans_DD_A3L.mxd*caroline.souday*17/11/2021

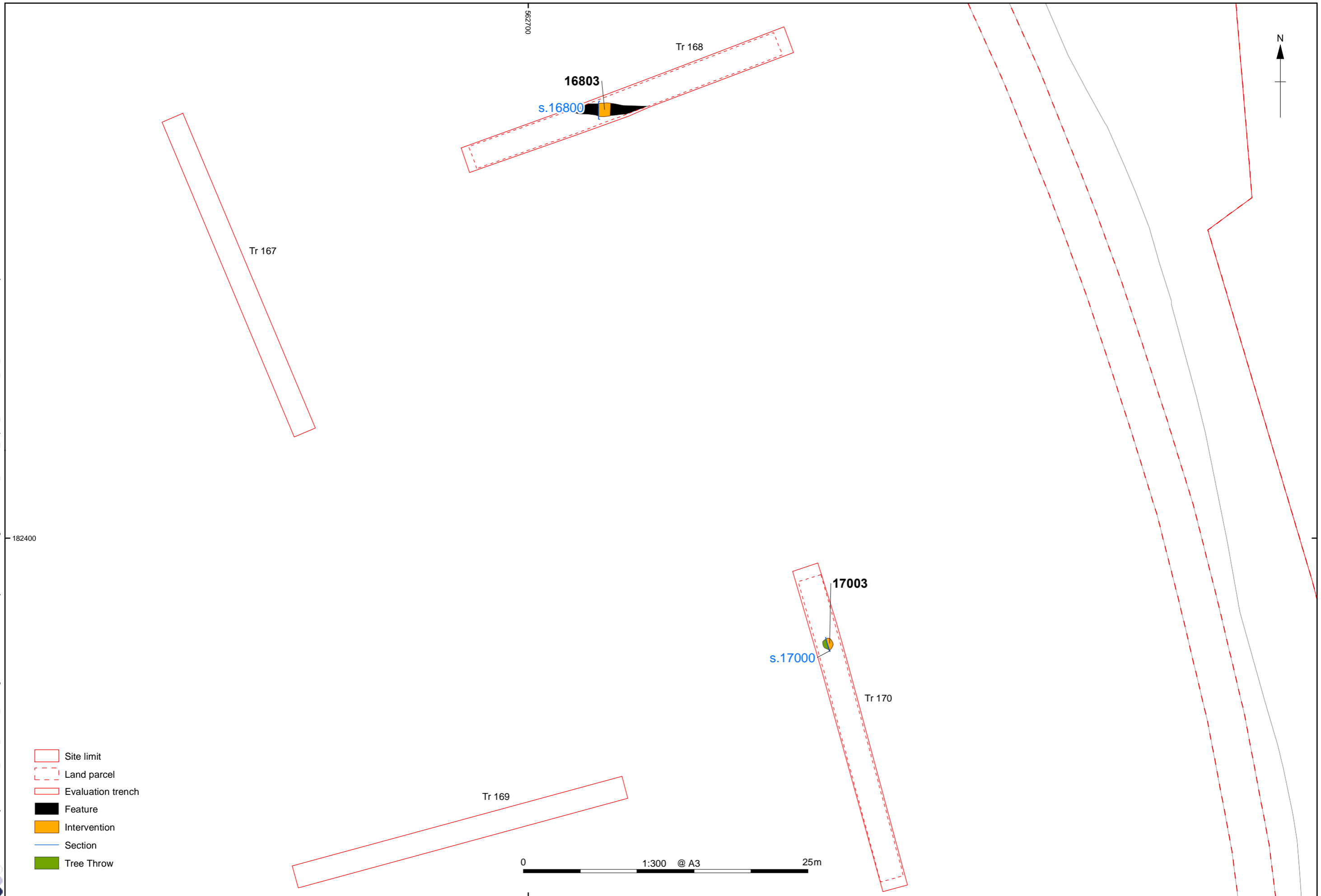

Figure 15: Plan of Trenches 167-8 and 170

\\10.0.10.86\Projects\ILTCEV_Lower_Thames_Crossing\010Geomatics\03 GIS Projects - LT07L21\Figures\TC43M21_48B-48C_Report_TrenchPlans_DD_A3.mxd caroline.souday*17/11/2021

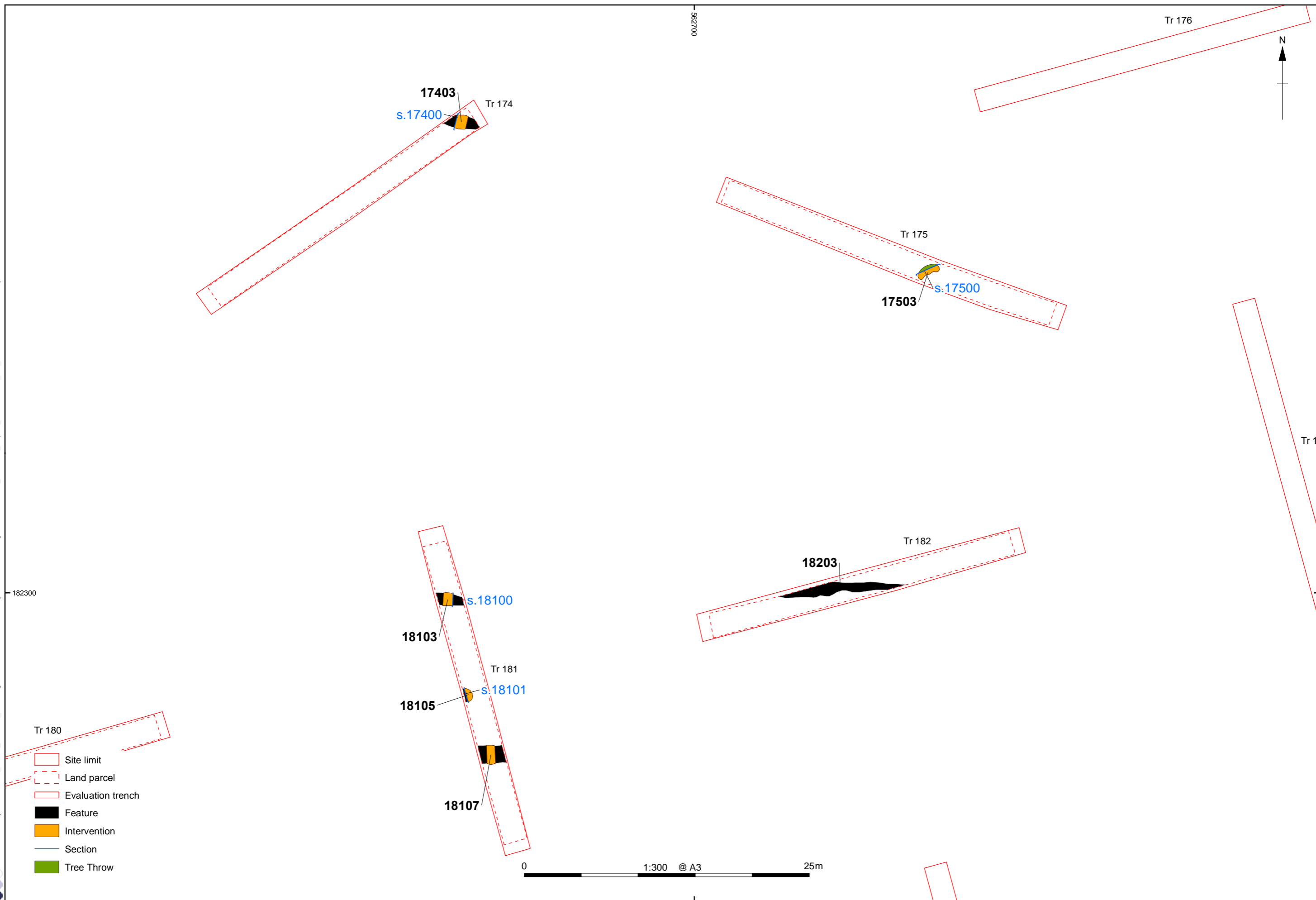

Figure 16: Plan of Trenches 174-5 and 181-2

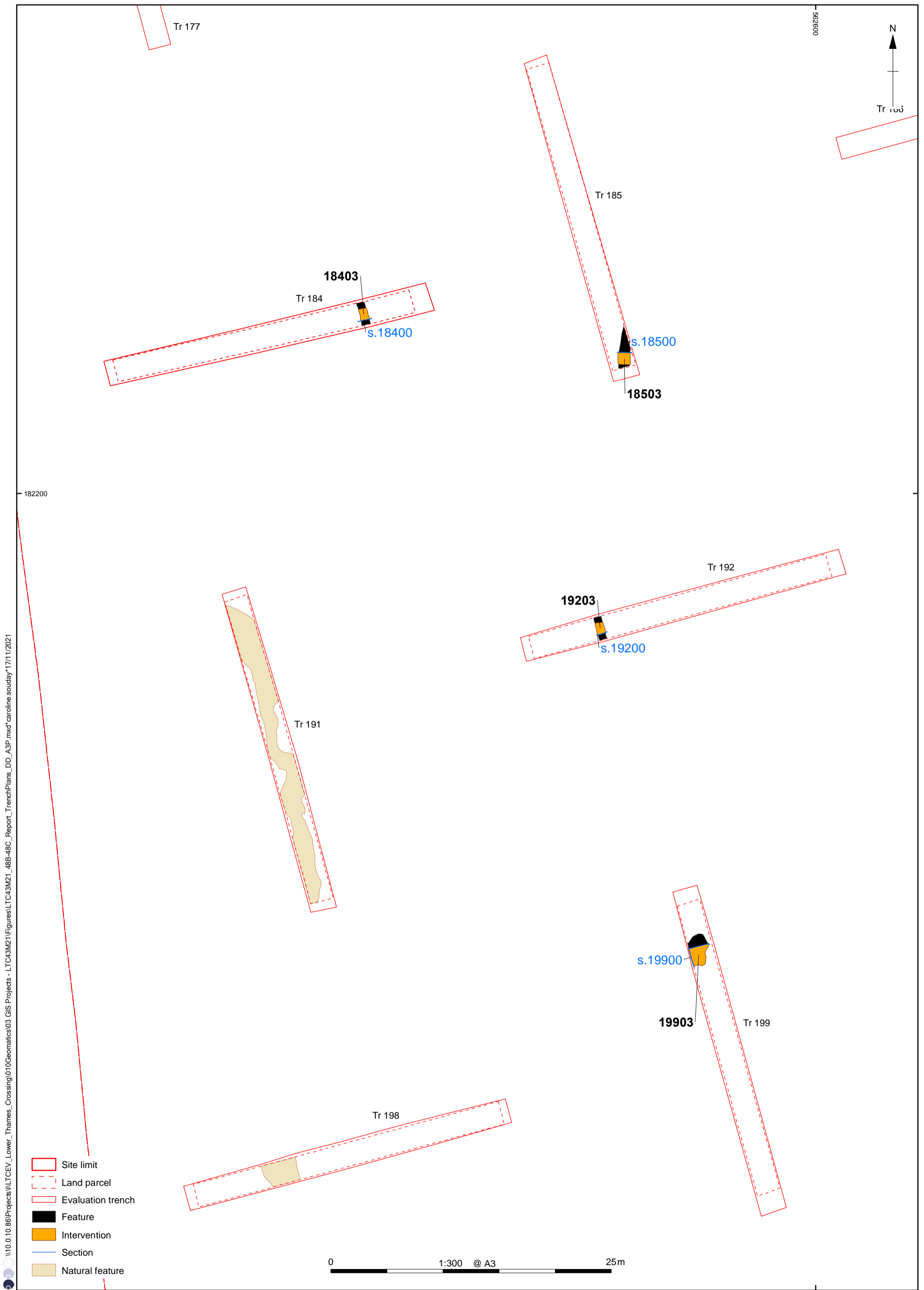

Figure 17: Plan of Trenches 184-5, 191-2 and 199

\\10.0.10.86\Projects\ILTCEV_Lower_Thames_Crossing\010Geomatics\03 GIS Projects - LT07L21\Figures\TC43M21_48B-48C_Report_TrenchPlans_DD_A3.mxd caroline.souday*17/11/2021

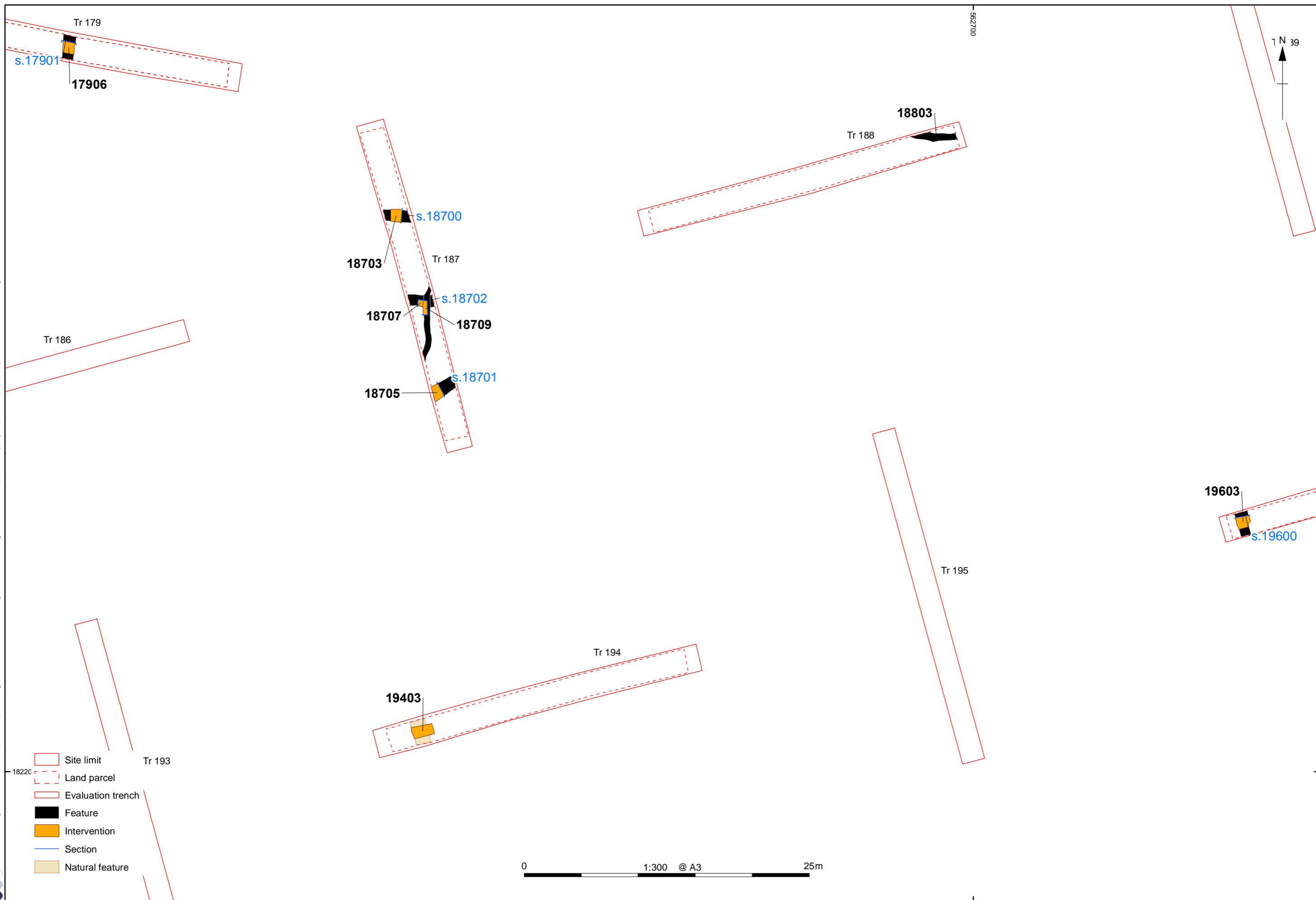

Figure 18: Plan of Trenches 187-8 and 194

\\10.0.10.86\Projects\ITCEV_Lower_Thames_Crossing\010Geomatics\03 GIS Projects - LT07L21\Figures\TC43M21_48B-48C_Report_TrenchPlans_DD_A3L.mxd*caroline.souday*17/11/2021

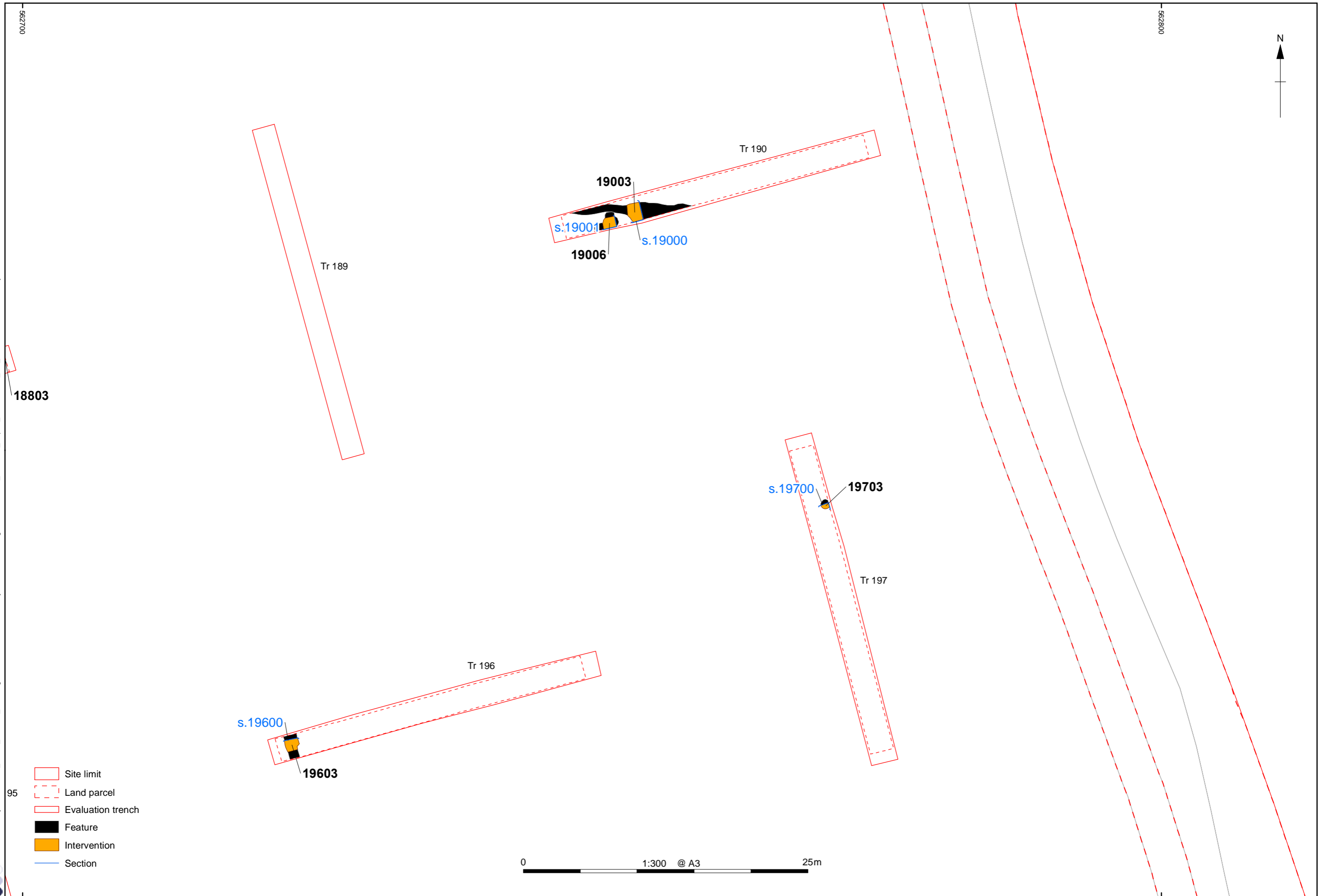

Figure 19: Plan of Trenches 189-90 and 196-7

\\10.0.10.86\Projects\ILTCEV_Lower_Thames_Crossing\010\Geomatics\03 GIS Projects - LTC43M2\1\Figures\LTC43M2_48B-48C_Report_TrenchPlans_DD_A3L.mxd+LS03.11.21

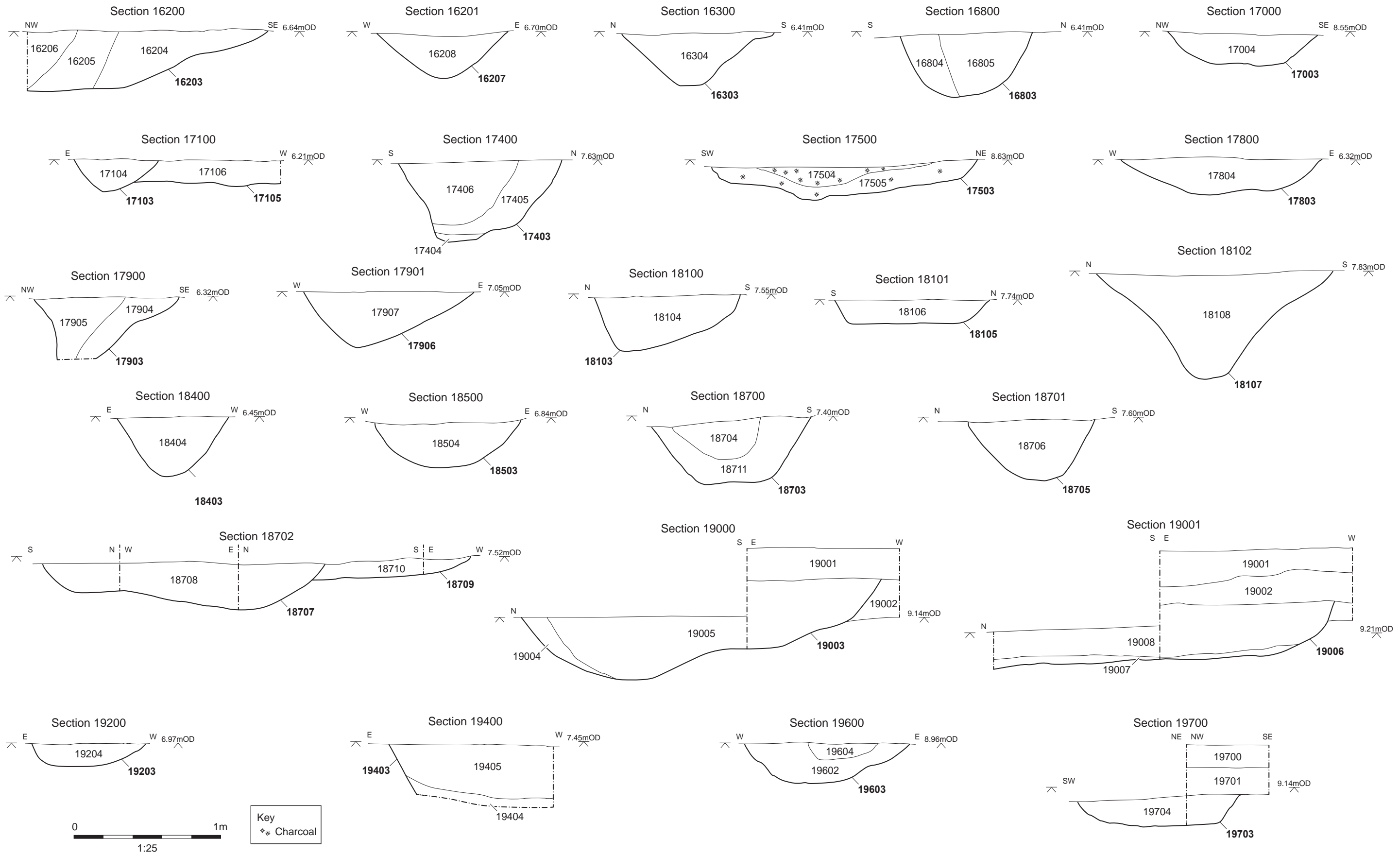

Figure 20: Sections (Trenches 162-3, 168, 170-1, 174-5, 178-9, 181, 184-5, 187, 190, 192, 194 and 196-7)

\\10.0.10.86\Projects\Lower_Thames_Crossing\010\Geomatics\03 GIS Projects - LTC43M21\Figures\LTC43M21_48B-48C_Report_TrenchPlans_DD_A3P.mxd*caroline.souday*17/11/2021

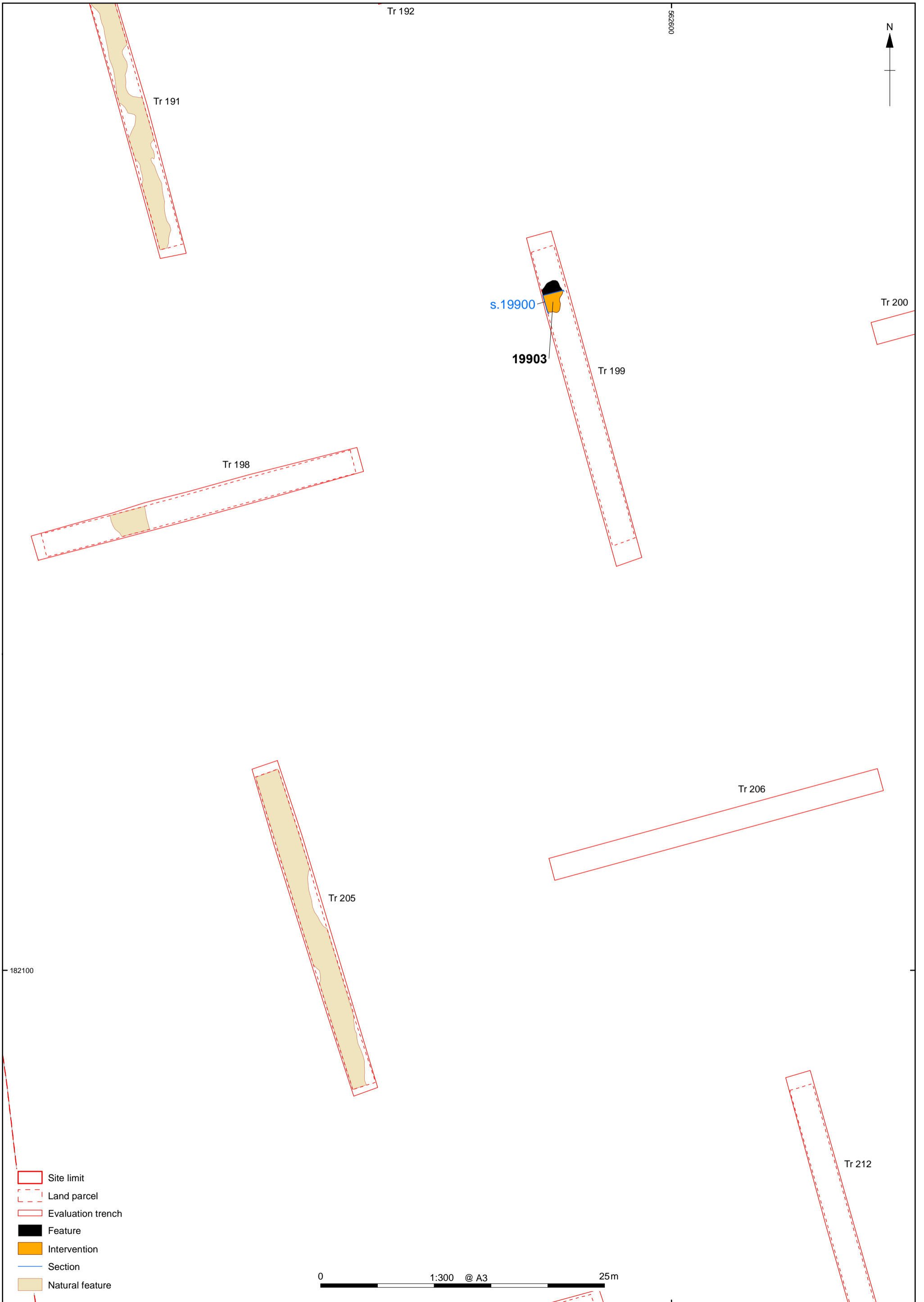

Figure 21: Plan of Trenches 198-9 and 205-6

\\10.0.10.86\Projects\Lower_Thames_Crossing\010\Geomatics\GIS\Projects - LT\7\21\Figures\TC43M21_48B-48C_Report_TrenchPlans_DD_A3.mxd caroline.souday*17/11/2021

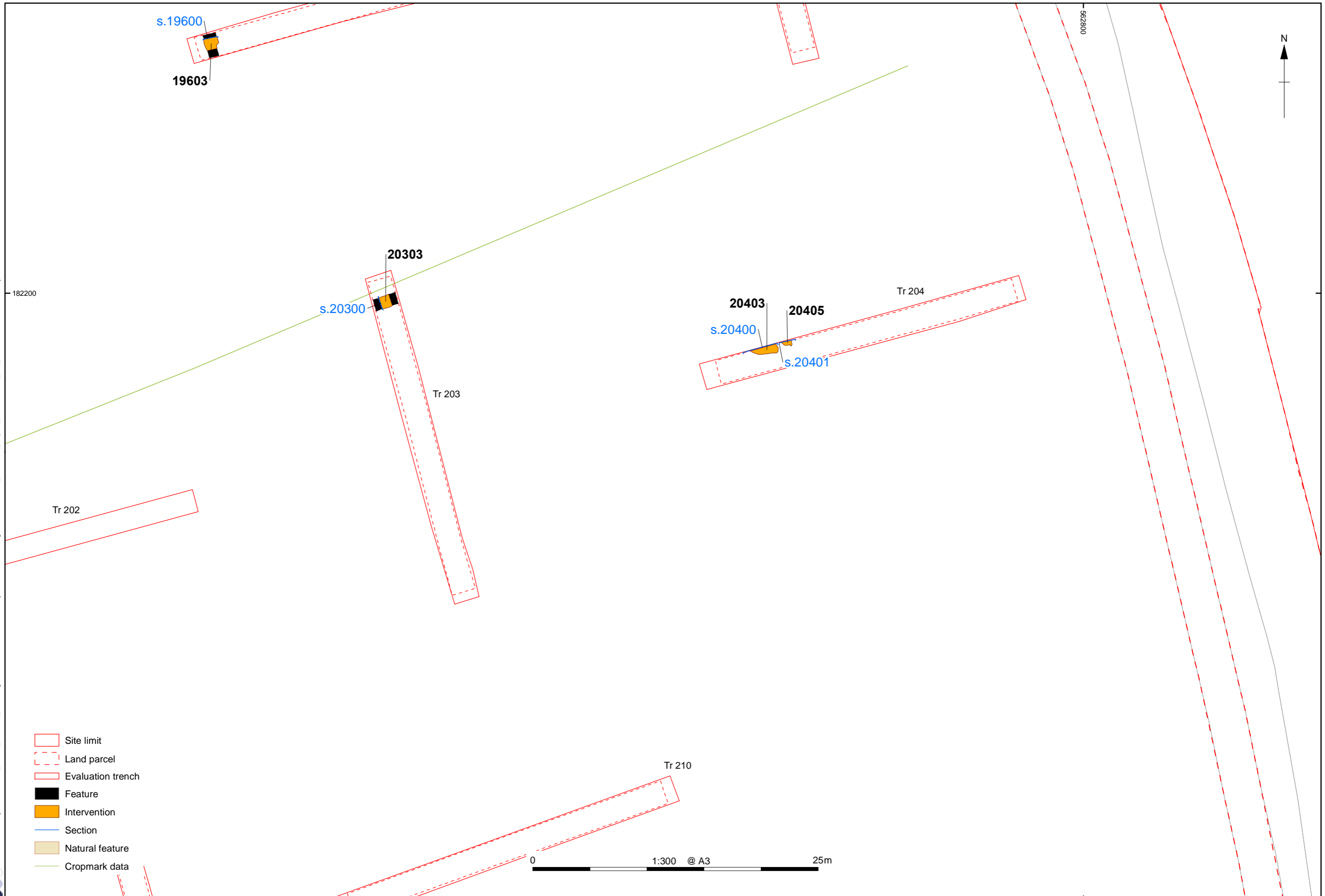

Figure 22: Plan of Trenches 203-4

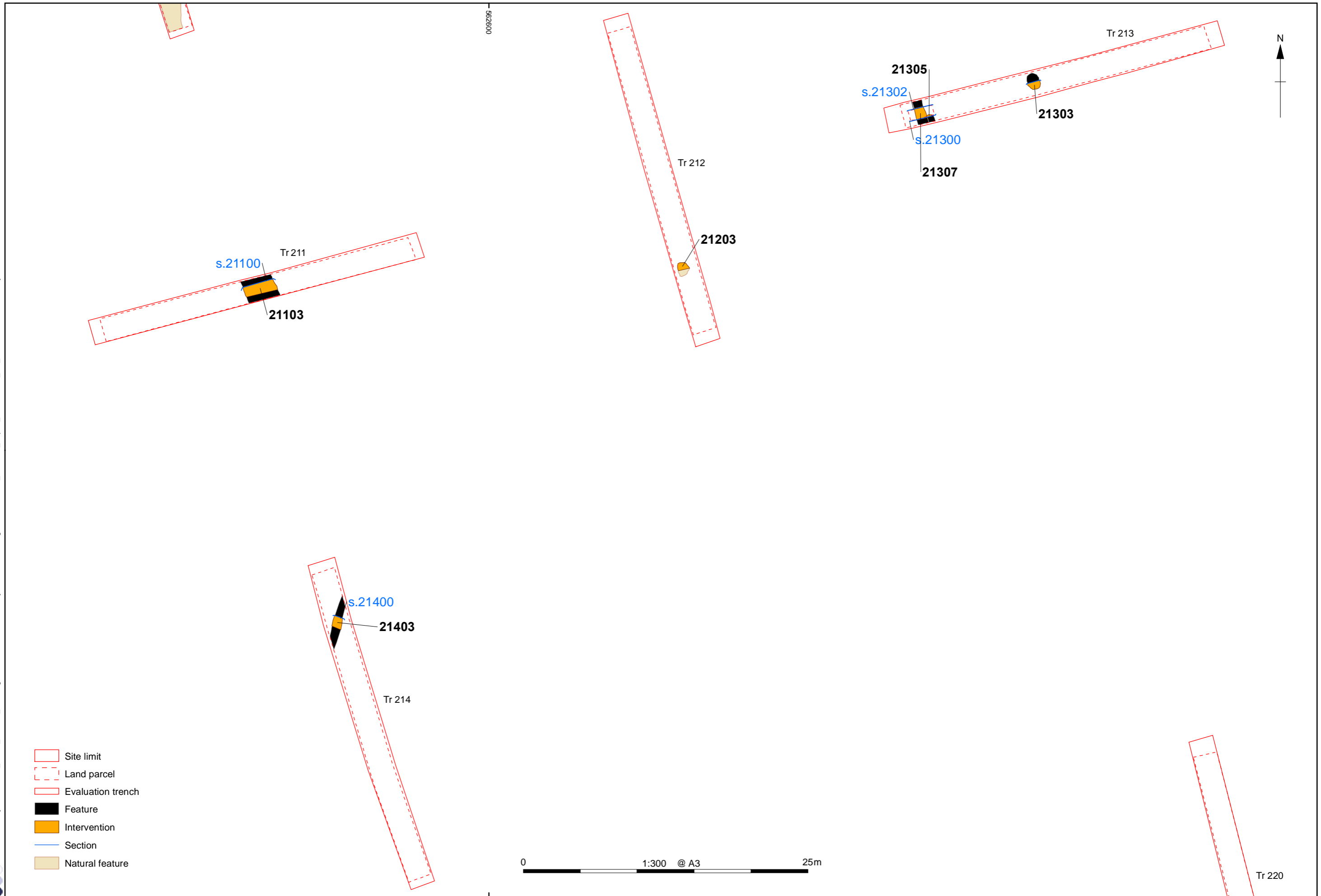

Figure 23: Plan of Trenches 211-14

\\10.0.10.86\Projects\Lower_Thames_Crossing\010\Geomatics\03 GIS Projects - LT\7L21\Figures\TC43M21_48B-48C_Report_TrenchPlans_DD_A3.mxd caroline.souday*17/11/2021

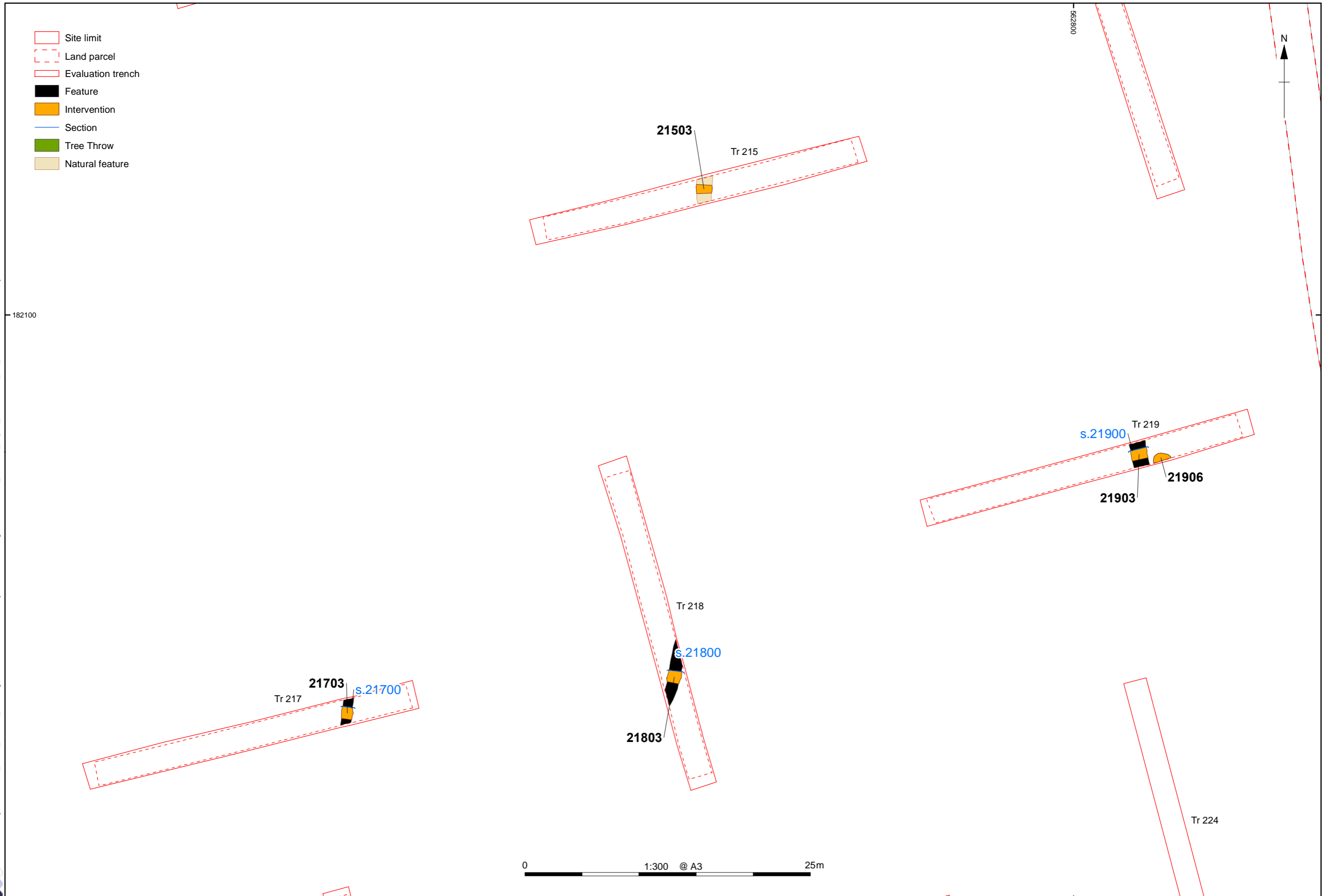

Figure 24: Plan of Trenches 215 and 217-19

\\10.0.10.86\Projects\ILTCEV_Lower_Thames_Crossing\010\Geomatics\03 GIS Projects - LT\7L21\Figures\TC43M21_48B-48C_Report_TrenchPlans_DD_A31.mxd\caroline.souday*17/11/2021

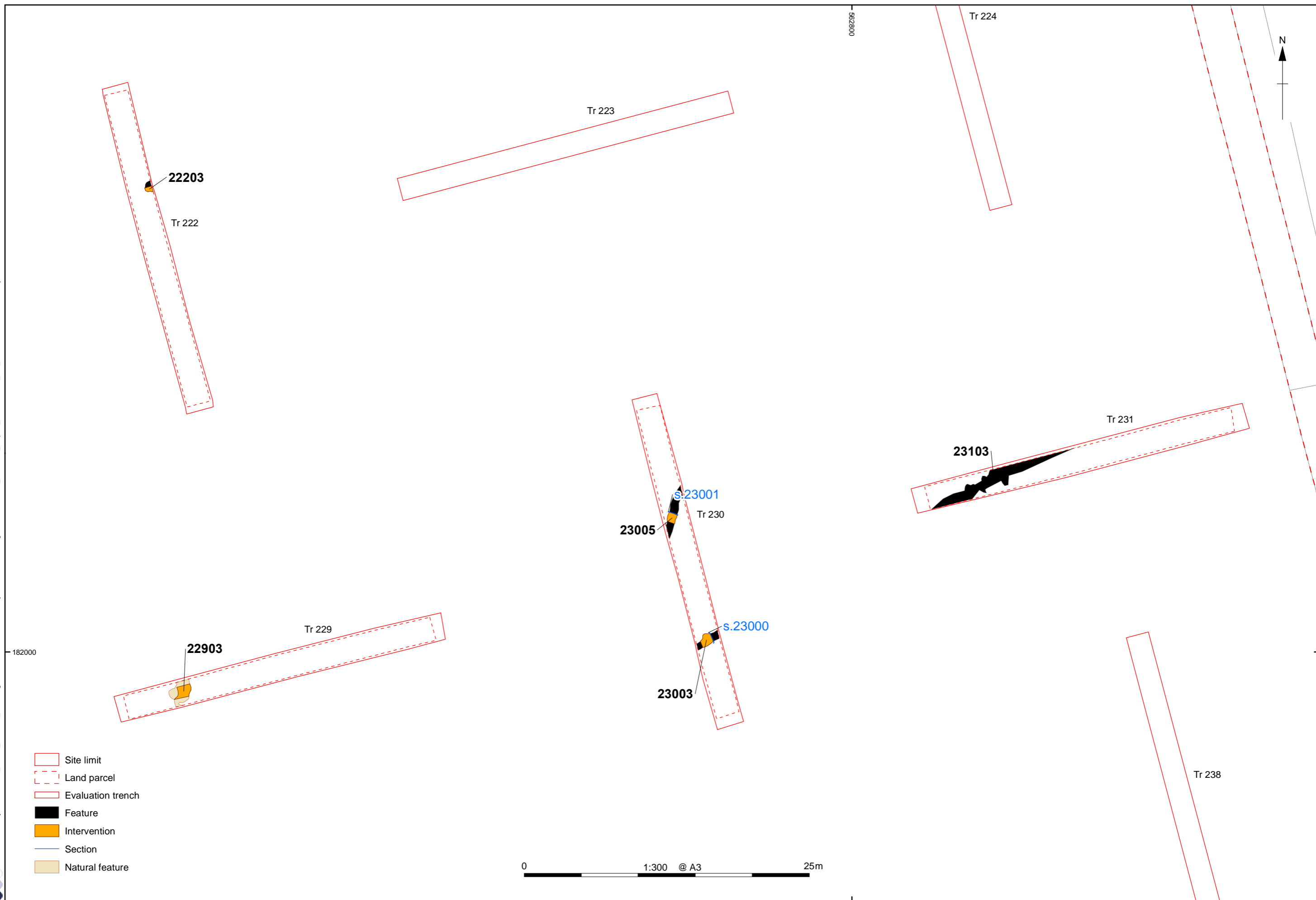

Figure 25: Plan of Trenches 222 and 229-31

\\10.0.10.86\Projects\ITCEV_Lower_Thames_Crossing\010\Geomatics\03 GIS Projects - LT\7L21\Figures\TC43M21_48B-48C_Report_TrenchPlans_DD_A3.mxd caroline.souday*17/11/2021

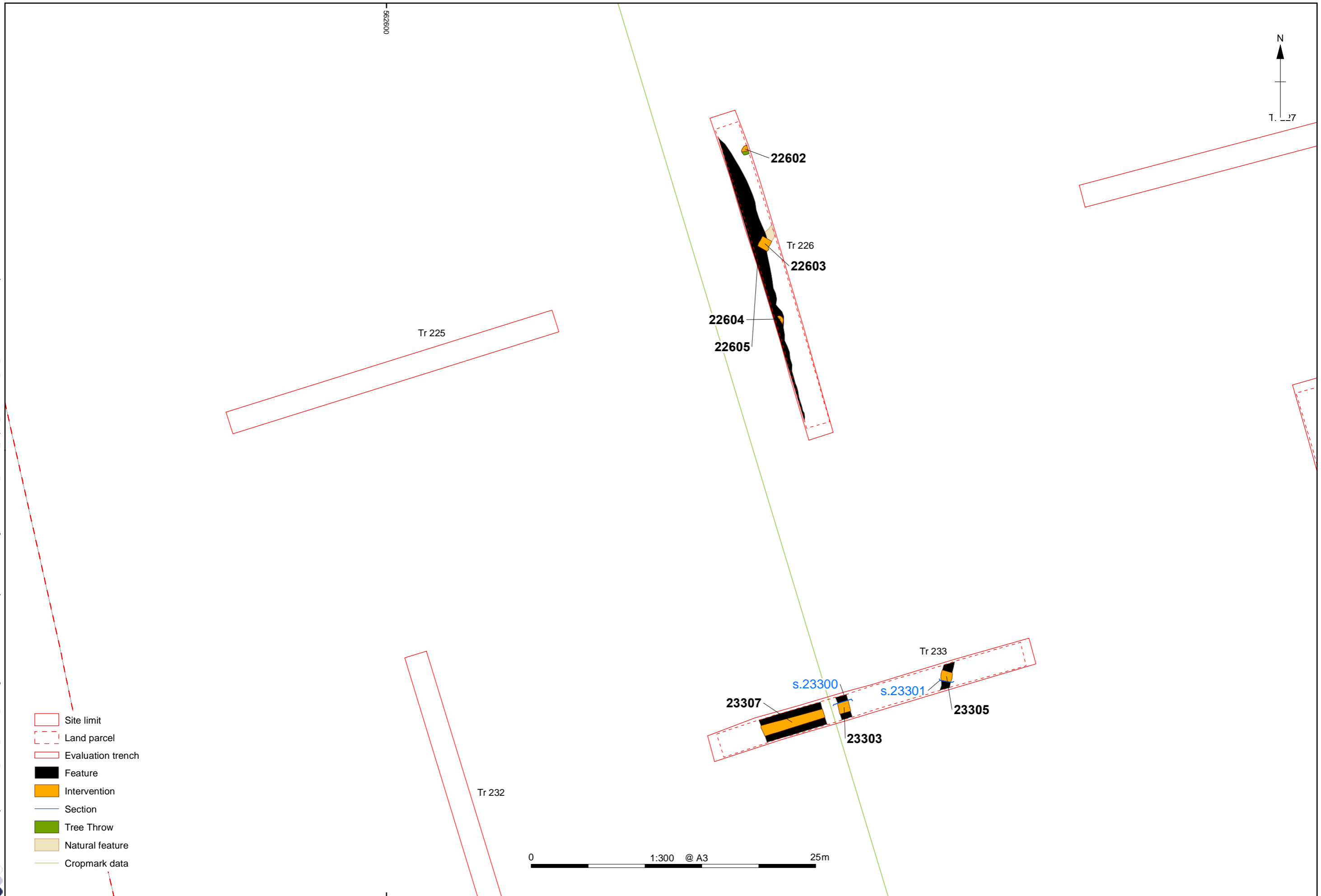

Figure 26: Plan of Trenches 225-6 and 233

\\10.0.10.86\Projects\10\Geomatics\03 GIS Projects - LTC43M2\1\Figures\LTC43M2_48B-48C_Report_TrenchPlans_DD_A3L.mxd+LS03.11.21

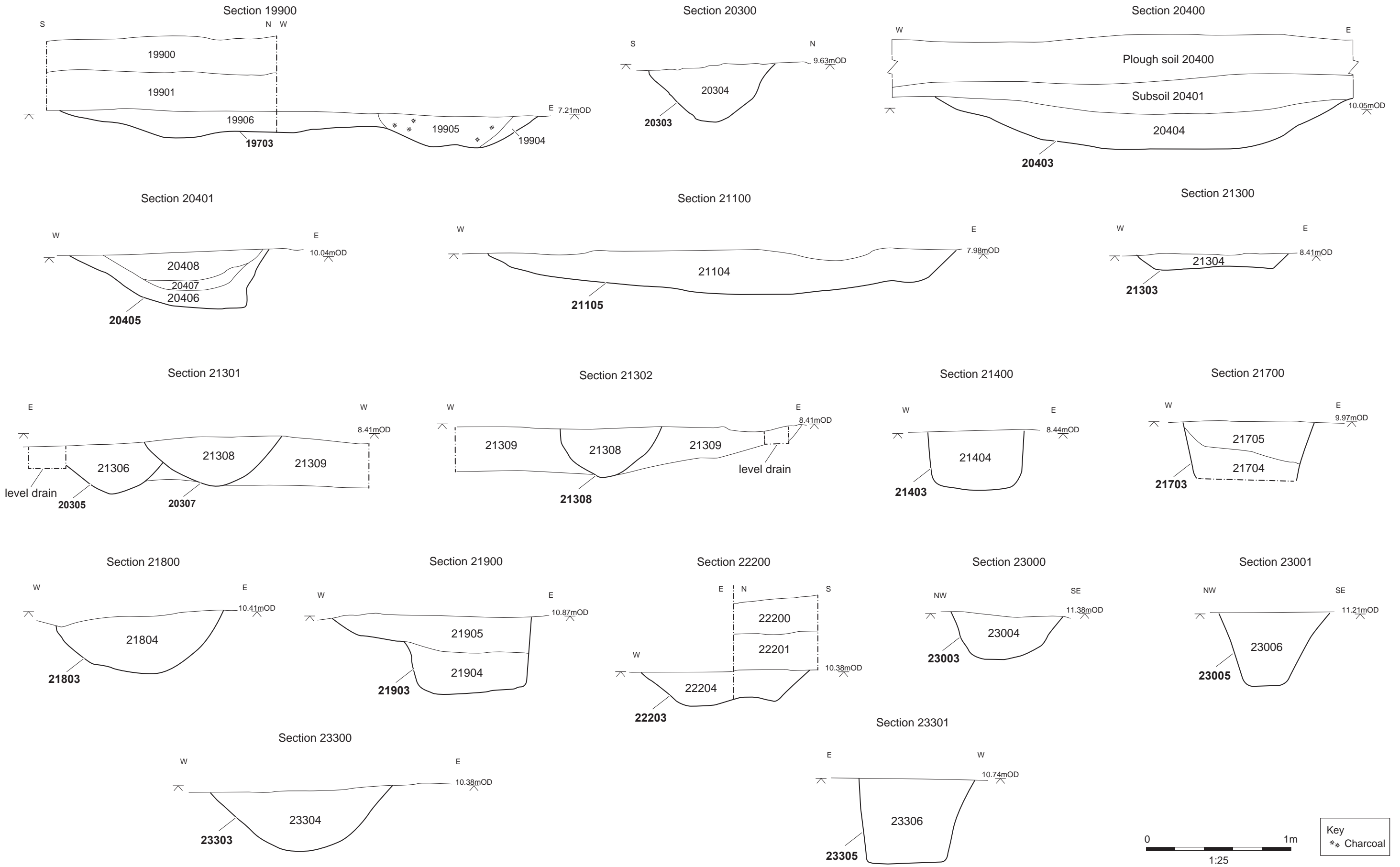

Figure 27: Sections (Trenches 199, 203-4, 211, 213-14, 217-19, 222, 230 and 233)

\\10.0.10.86\Projects\Lower_Thames_Crossing\010\Geomatics\03 GIS Projects - LTC43M21\Figures\LTC43M21_Report_TrenchPlans_DD_A3P.mxd*caroline.soudry*17/11/2021

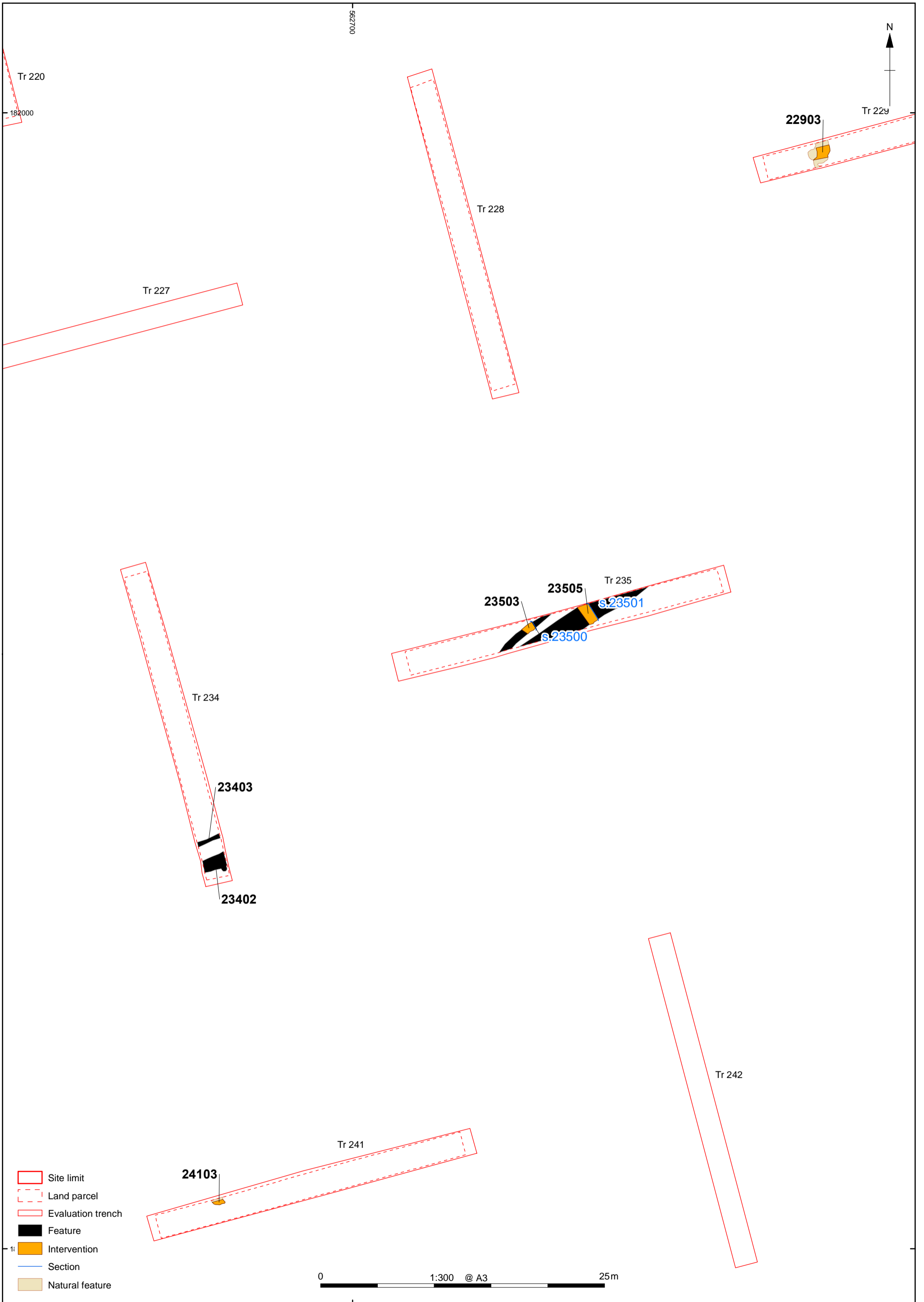
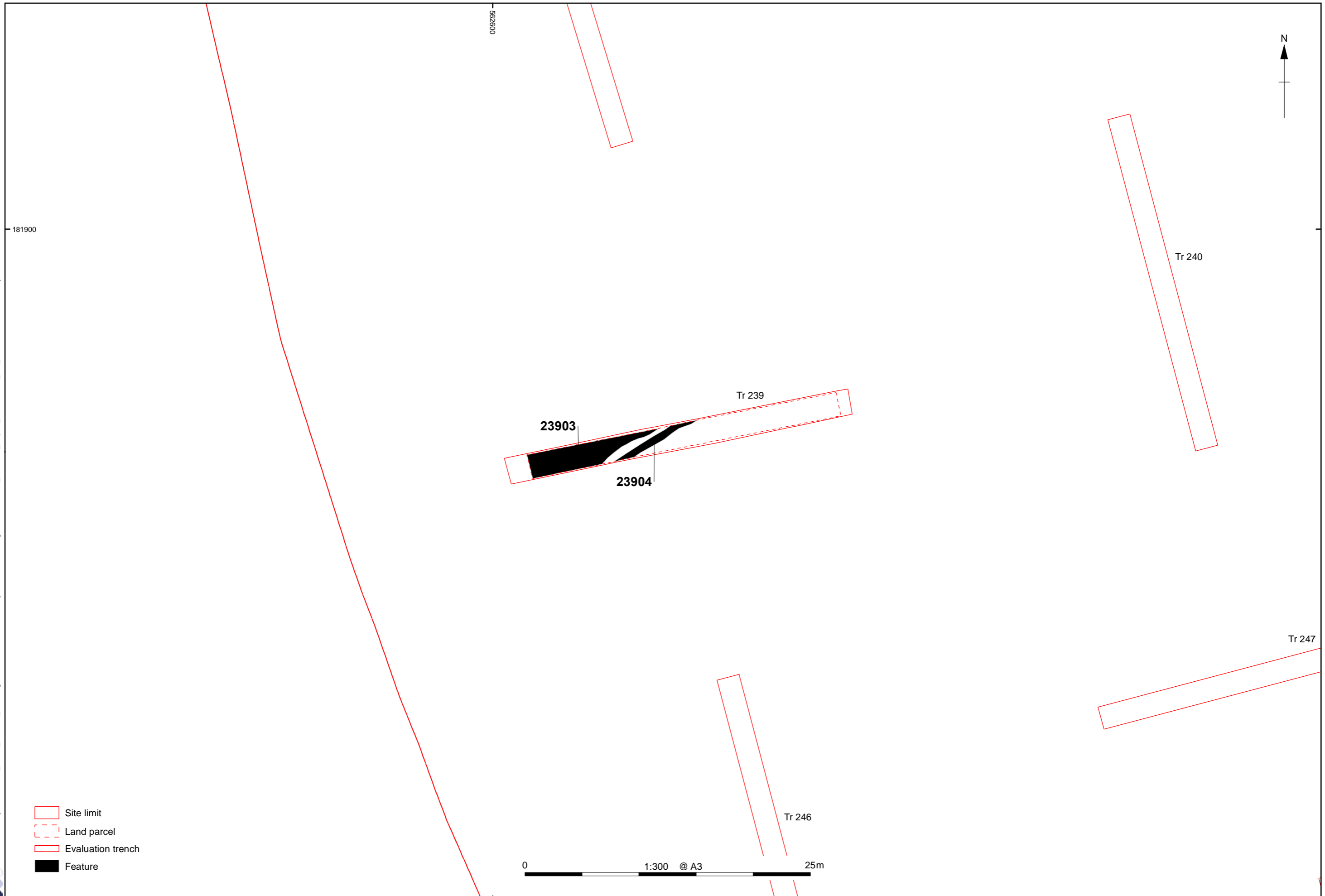

Figure 28: Plan of Trenches 234-5

\\10.0.10.86\Projects\TCEV_Lower_Thames_Crossing\010Geomatics\03 GIS Projects - LT\7L21\Figures\TC43M21_48B-48C_Report_TrenchPlans_DD_A3L.mxd\caroline.souday*17/11/2021



- Site limit
- Land parcel
- Evaluation trench
- Feature

0 1:300 @ A3 25m

Figure 29: Plan of Trench 239

\\10.0.10.86\Projects\ILTCEV_Lower_Thames_Crossing\010Geomatics\03 GIS Projects - LT\7L21\Figures\TC43M21_48B-48C_Report_TrenchPlans_DD_A3L.mxd caroline.souday*17/11/2021

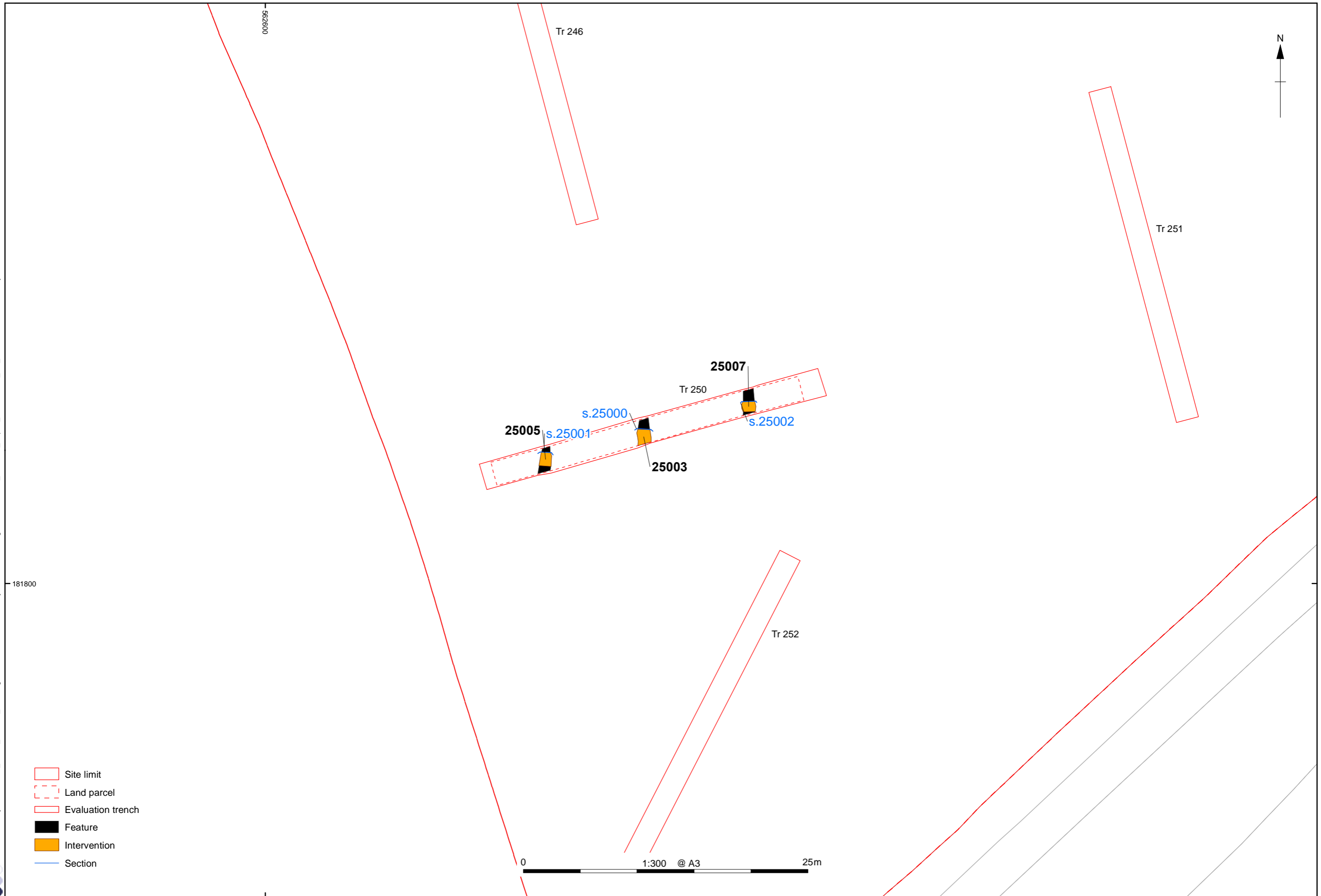

- Site limit
- Land parcel
- Evaluation trench
- Feature
- Intervention
- Section

0 1:300 @ A3 25m

Figure 30: Plan of Trench 250

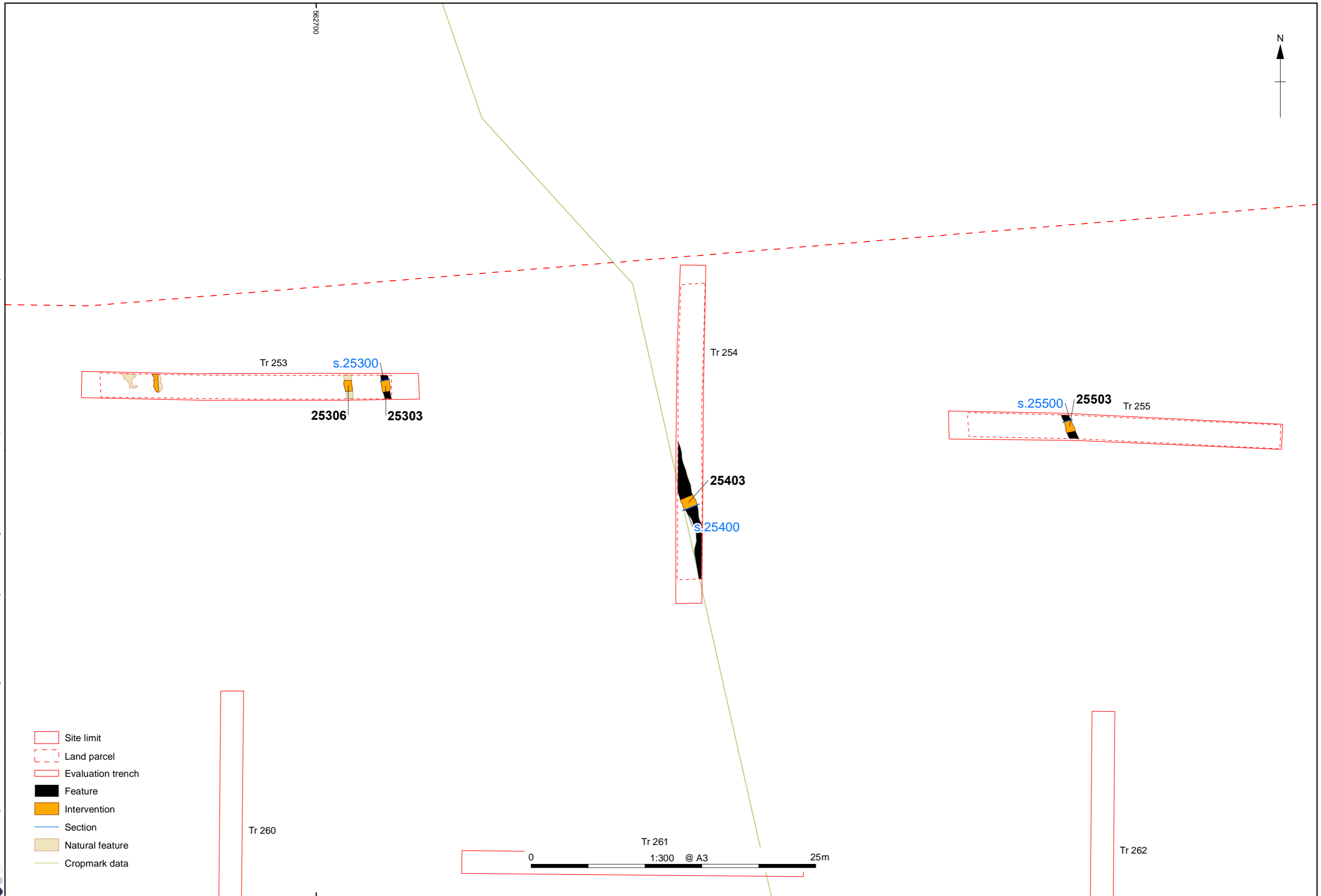

Figure 31: Plan of Trenches 253-5

\\10.0.10.86\Projects\ILTCEV_Lower_Thames_Crossing\010\Geomatics\03 GIS Projects - LT07L21\Figures\TC43M21_48B-48C_Report_TrenchPlans_DD_A3.mxd*caroline.souday*17/11/2021

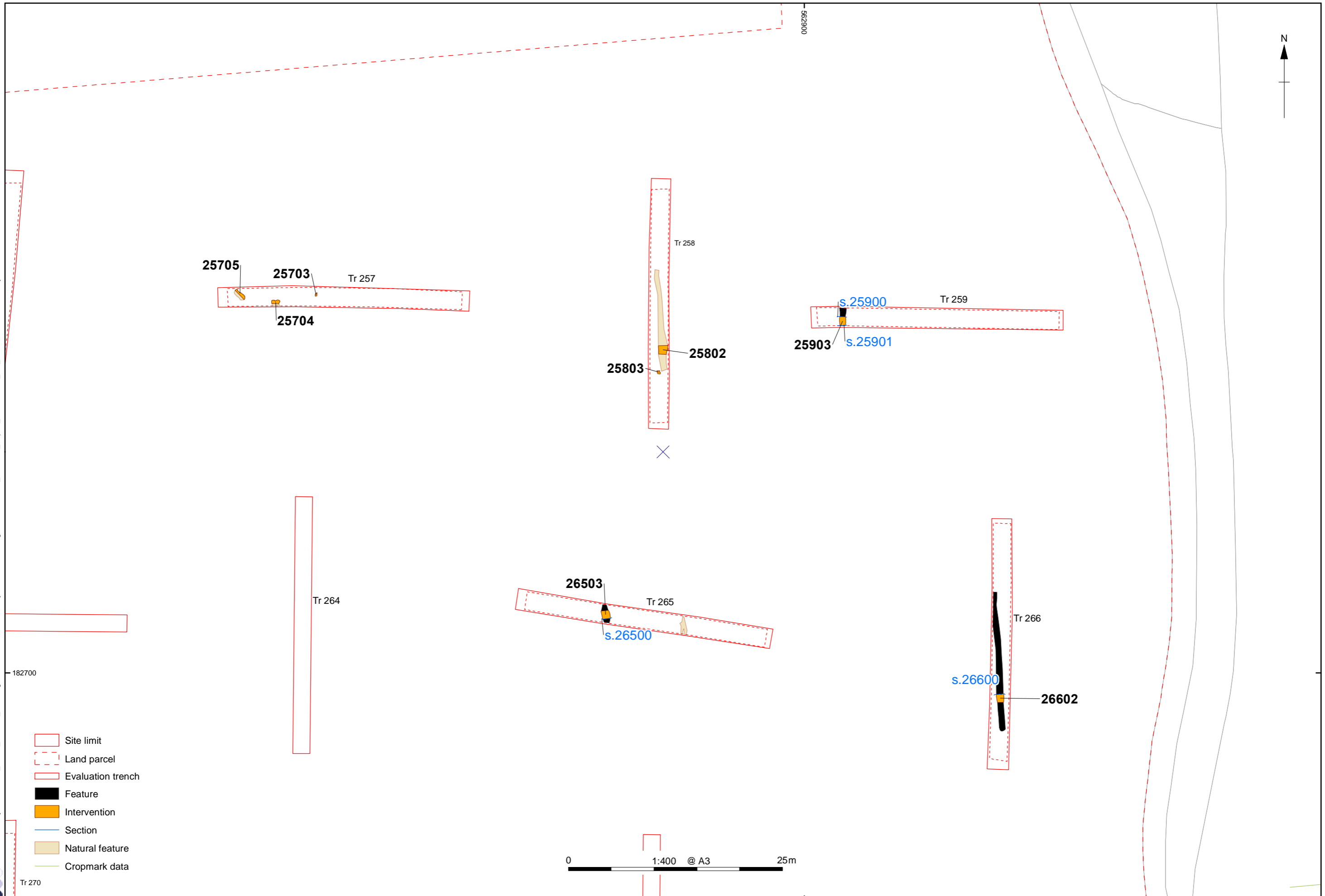

Figure 32: Plan of Trenches 257-9 and 264-6

\\10.0.10.86\Projects\ILTCEV_Lower_Thames_Crossing\010Geomatics\03 GIS Projects - LT07L21\Figures\TC43M21_48B-48C_Report_TrenchPlans_DD_A3L.mxd\caroline.souday*17/11/2021

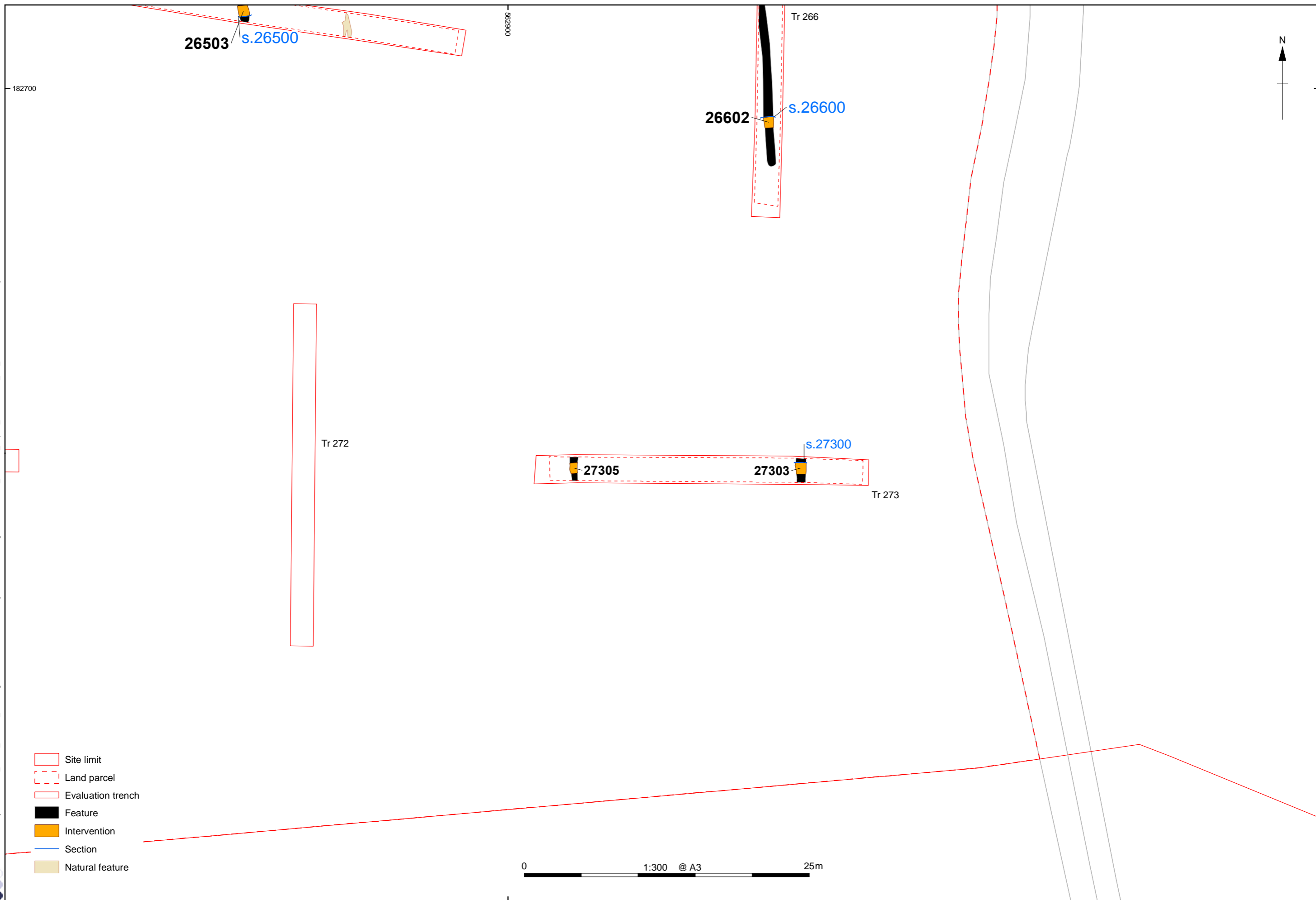

Figure 33: Plan of Trench 273

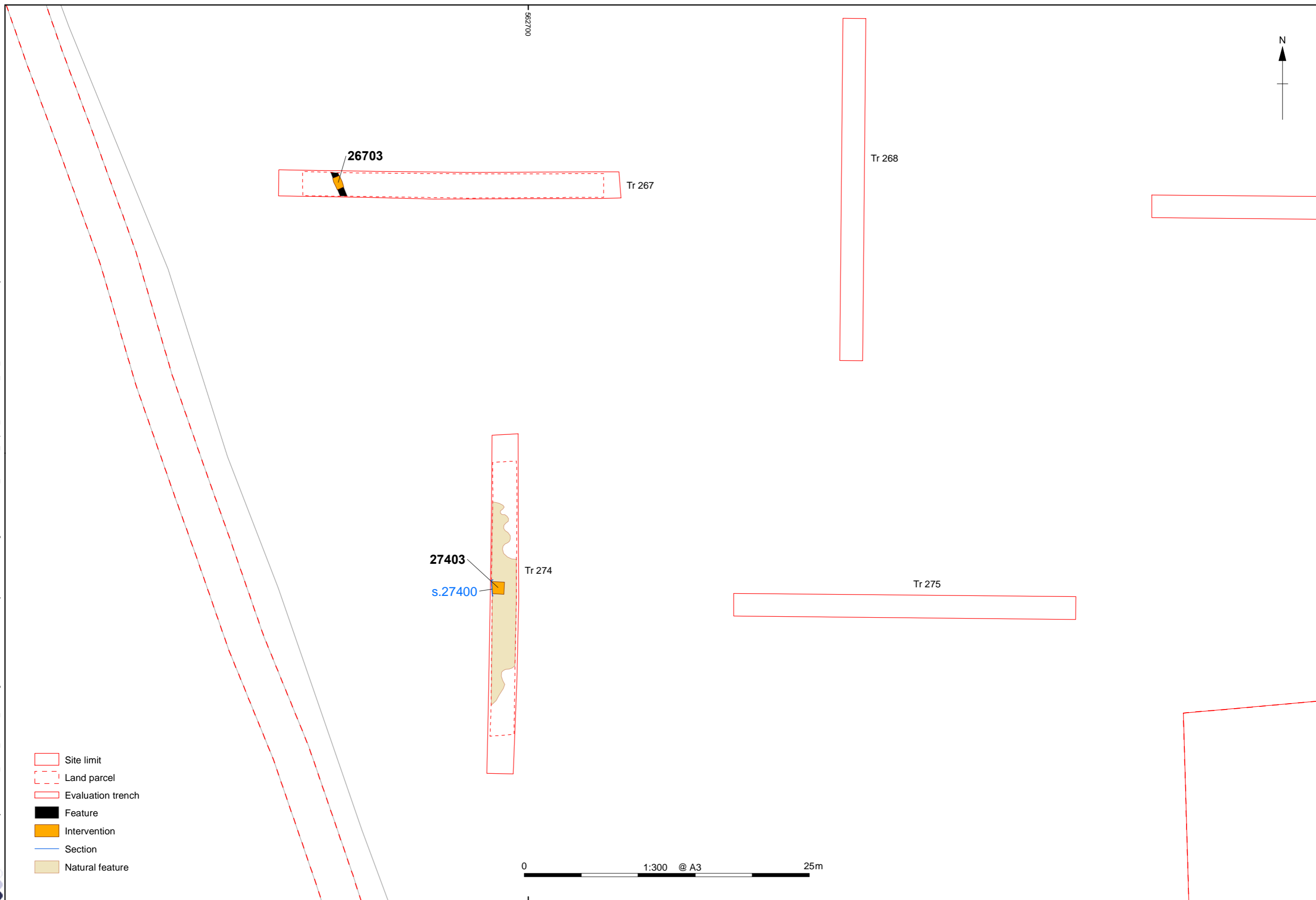
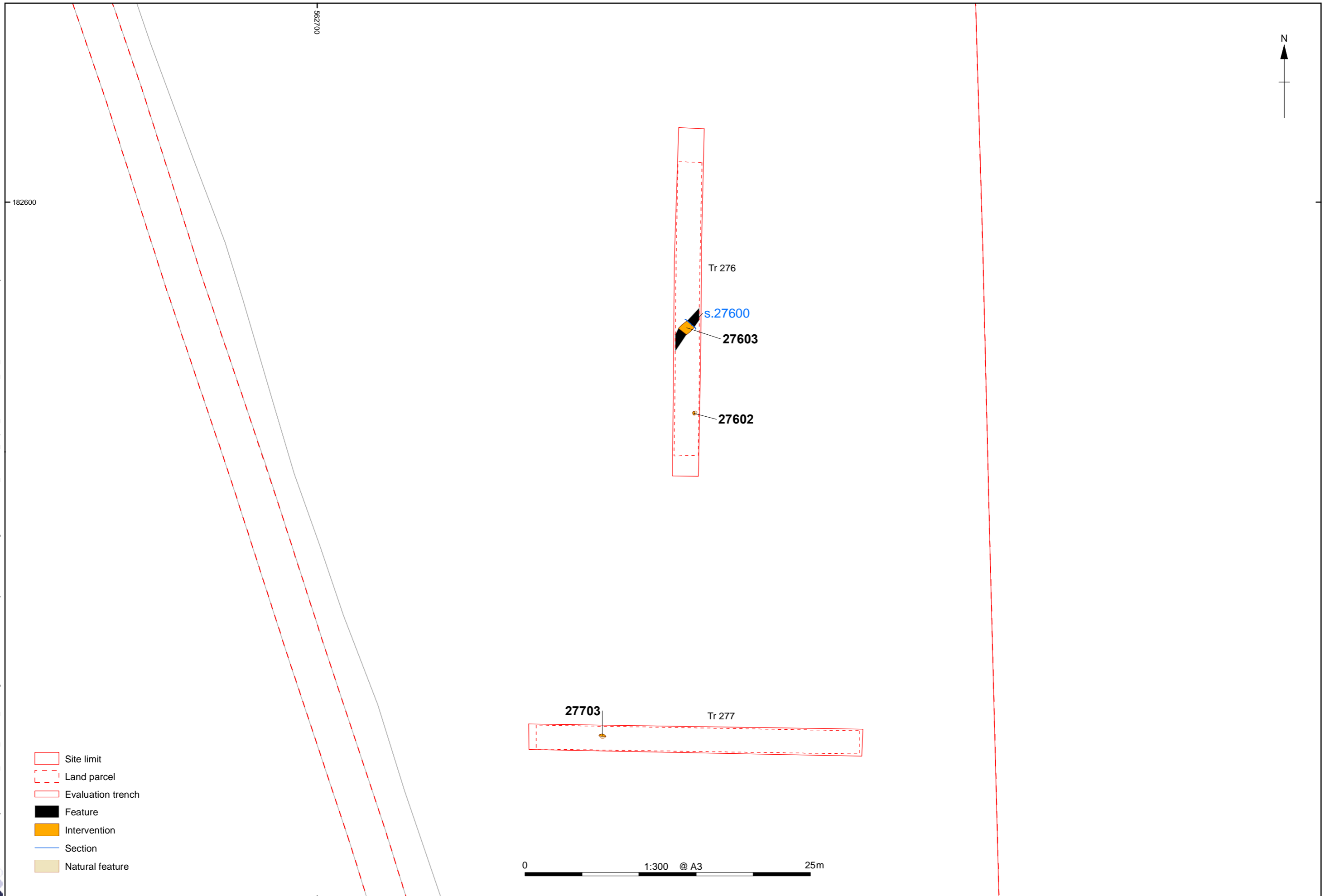

Figure 34: Plan of Trenches 267-8 and 274-5

\\10.0.10.86\Projects\Lower_Thames_Crossing\GIS\Projects - L\TC7L21\Figures\TC43M21_48B-48C_Report_TrenchPlans_DD_A3.mxd caroline.souday*17/11/2021



- Site limit
- Land parcel
- Evaluation trench
- Feature
- Intervention
- Section
- Natural feature

0 1:300 @ A3 25m

Figure 35: Plan of Trenches 276-7

\\10.0.10.86\Projects\TCEV_Lower_Thames_Crossing\GIS\Projects - LTC43M2\1\Figures\LTC43M2_48B-48C_Report_TrenchPlans_DD_A3L.mxd+LS03:11.21

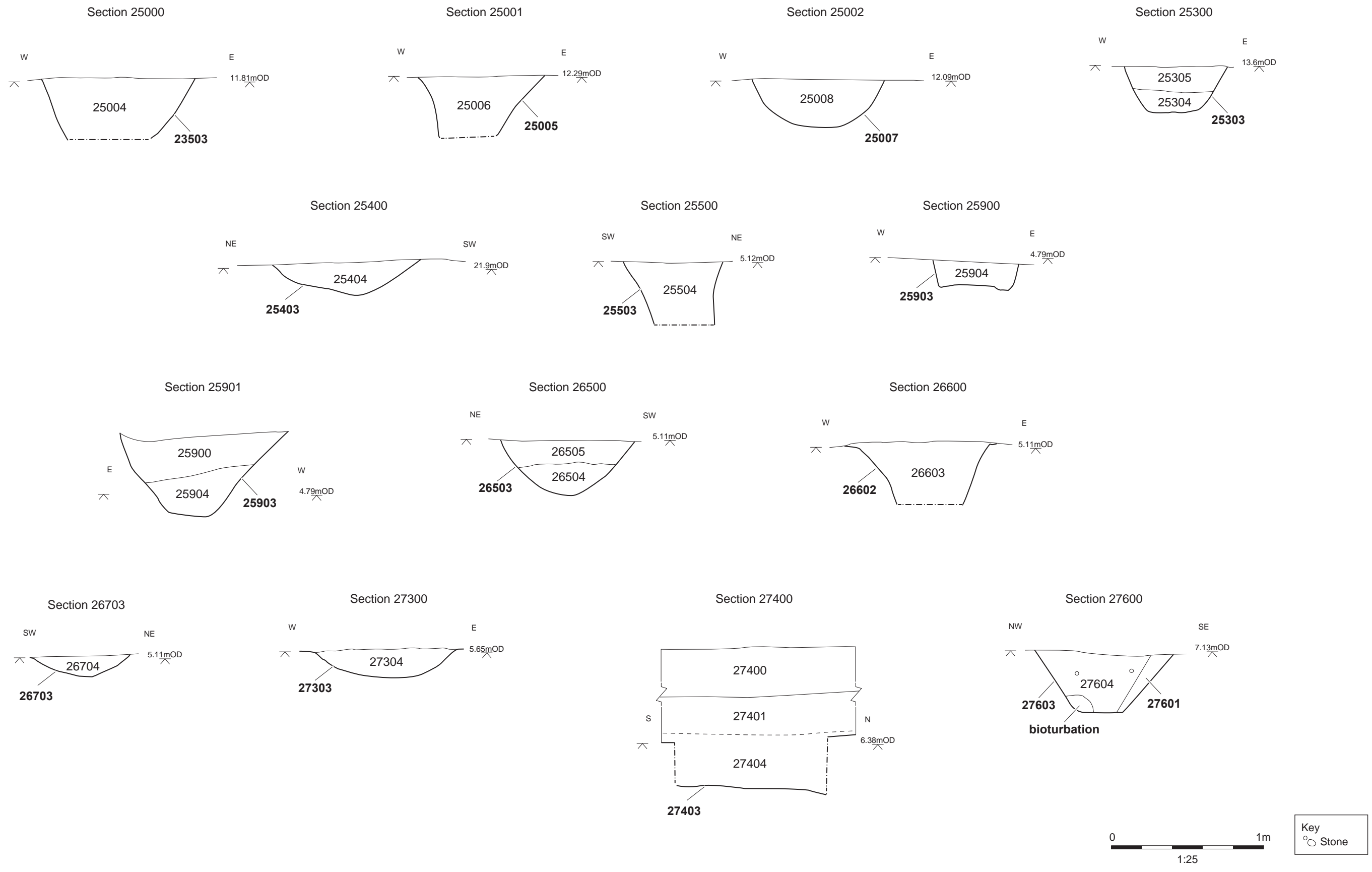

Figure 36: Sections (Trenches 250, 253-5, 259, 265-7, 273-4 and 276)



Plate 1: Ditch 12703 looking NNW



Plate 2: Ditch 14403 looking north-west



Plate 3: Ditches 12904/12906 looking north-east



Plate 4: Ditch 13203 looking west

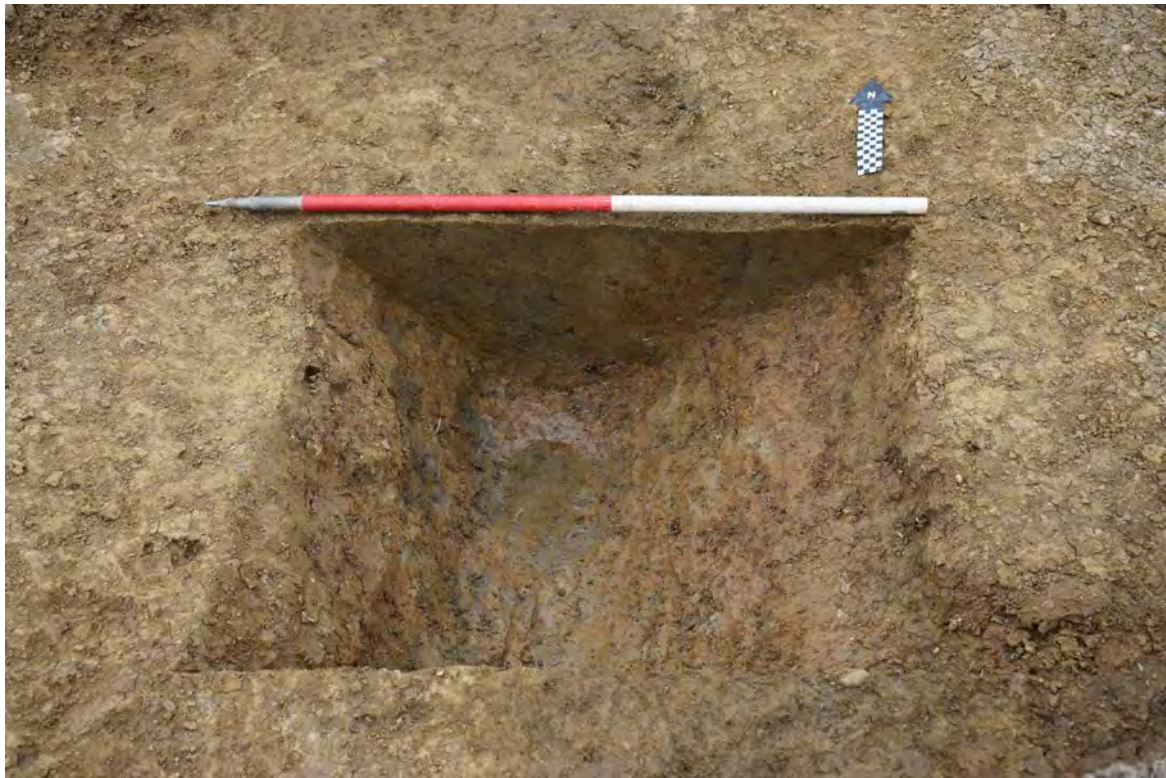

Plate 5: Ditch 13103 looking north



Plate 6: Ditch 14303 looking west



Plate 7: Ditch 13305 looking north-west



Plate 8: Pit 13307 looking north-west



Plate 9: Ditch 16303 looking north-east



Plate 10: Ditch 16803 looking west



Plate 11: Ditch 17403 looking west



Plate 12: Ditch 18103 looking east



Plate 13: Ditch 18107 looking east



Plate 14: Tree-throw 17503 looking north-west



Plate 15: Ditch 18403 looking south-east



Plate 16: Ditch 19203 looking south



Plate 17: Ditch 18503 looking north



Plate 18: Ditch 18703 looking east



Plate 19: Ditch 21703 looking west



Plate 20: Ditch 25005 looking north



Plate 21: Ditch 21803 looking north



Plate 22: Ditch 21903 looking north



Plate 23: Ditch 27603 looking north-east

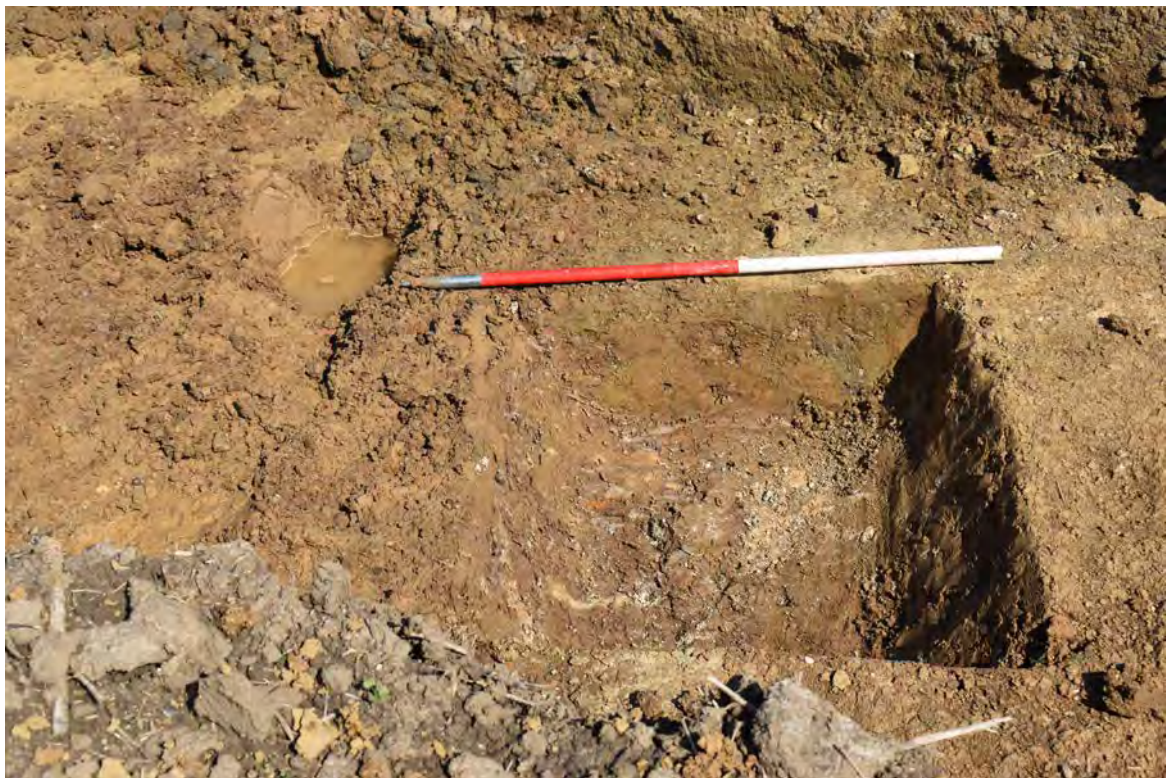

Plate 24: Ditch 26503 looking north-east



Plate 25: Natural Feature 27403 looking west



Plate 26: Trench 122



Plate 27: Trench 136



Plate 28: Trench 146

If you need help accessing this or any other National Highways information, please call **0300 123 5000** and we will help you.

© Crown copyright 2022.

You may re-use this information (not including logos) free of charge in any format or medium, under the terms of the Open Government Licence. To view this licence:

visit www.nationalarchives.gov.uk/doc/open-government-licence/

write to the **Information Policy Team, The National Archives, Kew, London TW9 4DU**, or email psi@nationalarchives.gsi.gov.uk.

Mapping (where present): © Crown copyright and database rights 2022 OS 100030649. You are permitted to use this data solely to enable you to respond to, or interact with, the organisation that provided you with the data. You are not permitted to copy, sub-licence, distribute or sell any of this data to third parties in any form.

If you have any enquiries about this publication email info@nationalhighways.co.uk or call **0300 123 5000**.*

*Calls to 03 numbers cost no more than a national rate call to an 01 or 02 number and must count towards any inclusive minutes in the same way as 01 and 02 calls.

These rules apply to calls from any type of line including mobile, BT, other fixed line or payphone. Calls may be recorded or monitored.

Printed on paper from well-managed forests and other controlled sources when issued directly by National Highways.

Registered office Bridge House, 1 Walnut Tree Close, Guildford GU1 4LZ

National Highways Company Limited registered in England and Wales number 09346363